

# JT

sistema de correr com corte térmico  
sliding system with thermal break  
système coulissant à rupture de pont thermique



Antas Green  
A NOVA CLIMA

Hab Multifamiliar

## CATÁLOGO TÉCNICO

TECHNICAL CATALOG | CATALOGUE TECHNIQUE



# ÍNDICE

## TABLE OF CONTENTS | TABLE DE MATIÈRES

APRESENTAÇÃO PRESENTATION PRÉSENTATION	I
LISTAGEM DE PERFIS PROFILES LIST LISTE DES PROFILÉS	II
LISTAGEM DE ACESSÓRIOS ACCESSORIES LIST LISTE D'ACCESSOIRES	III
TIPOLOGIAS E MAPAS DE QUANTIDADES TYPOLOGIES AND QUANTITY MAPS TYPOLOGIES ET CARTES DES QUANTITÉS	IV
MAQUINAÇÕES DOS PERFIS PROFILES MACHININGS USINAGES DES PROFILÉS	V
MONTAGEM DOS PERFIS PROFILES ASSEMBLY ASSEMBLAGE DES PROFILÉS	VI
ANOTAÇÕES ANNOTATIONS REMARQUES	VII



**sistema de correr com corte térmico**  
**sliding system with thermal break**  
**système coulissant à rupture de pont thermique**



O sistema de correr JT é um sistema versátil, robusto e seguro, que permite a aplicação em vãos de maiores dimensões, compatível com tipologias de 1 a 8 folhas, em sistemas de 2, 3 ou 4 rails, soluções de canto e de embutir. De linhas simples e menores vistas de alumínio, este sistema perimetral com corte térmico vai ao encontro das atuais tendências arquitetónicas. Este sistema está também preparado para trabalhar em conjunto com o sistema de batente IT e redes mosquiteiras.

The JT system is a versatile, robust and secure system, which allows the appliance of larger frames, compatible with 1 to 8 sashes typologies, in systems of 2, 3 or 4 rails, corner solutions and pocket. With simple lines and smaller aluminum views, this perimeter system with thermal break meets the actual architectural trends. This system is also prepared to work with the IT opening system and mosquito nets.

Le système coulissant JT est un système polyvalent, robuste et sûr, qui permet une utilisation dans des portées plus importantes, compatibles avec des typologies allant de 2 à 8 vantaux, dans des systèmes à 2, 3 ou 4 rails et solutions d'angle. Avec ses lignes simples et ses vues en aluminium plus étroites, ce système périmétral à rupture de pont thermique répond aux tendances architecturales actuelles. Ce système est également préparé pour fonctionner avec le système de battant IT et les moustiquaires.

**APRESENTAÇÃO**

PRESENTATION | PRÉSENTATION

Reta | Straight | Droite

**DIMENSÕES**

DIMENSIONS | DIMENSIONS

Aro fixo | Fixed frame | Cadres dormant: 2Rail: 75mm | 96mm | 108mm | 117mm | 152mm  
3Rail: 152mm | 164mm  
4Rail: 220mm | 228mm  
Aro móvel | Mobile frame | Cadres ouvrants: 40mm | 44mm

**ENCHIMENTO**

FILLING | REMPLISSAGE

De 28 a 34mm | From 28 to 34mm | De 28 à 34mm

**CORTES**

CUTS | COUPES

45° | 90°

**VEDAÇÃO**

INSULATION | ÉTANCHÉITE

Juntas em EPDM | EPDM joints | Joints en EPDM  
Pelúcias STOP-FIN | STOP-FIN brushes | Joints brosse STOP-FIN

**POLIAMIDA**

POLYAMIDE | BARRETES

14mm | 24mm | 30mm | 36mm | 38mm | 40mm

**UNIÕES**

JOINTS | UNIONS

Esquadros de bloqueio | Corner cleats | Équerres d'angle: 9,5mm | 20,5mm

**ABERTURAS**

OPENINGS | OUVERTURES

2Rail: 1, 2, 3 ou | or | ou 4 folhas | sashes | vantaux  
3Rail: 3 ou | or | ou 6 folhas | sashes | vantaux  
4Rail: 4 ou | or | ou 8 folhas | sashes | vantaux

**PESO MÁXIMO**

MAXIMUM WEIGHT | POIDS MAXIMALE

280 Kg/folha | sash | vantail

**ÁREA MÁXIMA**

MAXIMUM AREA | AIRE MAXIMALE

4,50 m<sup>2</sup>/folha | sash | vantail

**LARGURA MÁXIMA**

MAXIMUM LENGTH | LARGEUR MAXIMALE

2,00 m/folha | sash | vantail

**ALTURA MÁXIMA**

MAXIMUM HEIGHT | HAUTEUR MAXIMALE

3,00 m/folha | sash | vantail

**ACABAMENTOS**

FINISHES | FINITIONS

Lacados | Powder coated | Laqué  
Anodizados | Anodised | Anodisé  
Bicolores | Bicolour | Bicoloreur

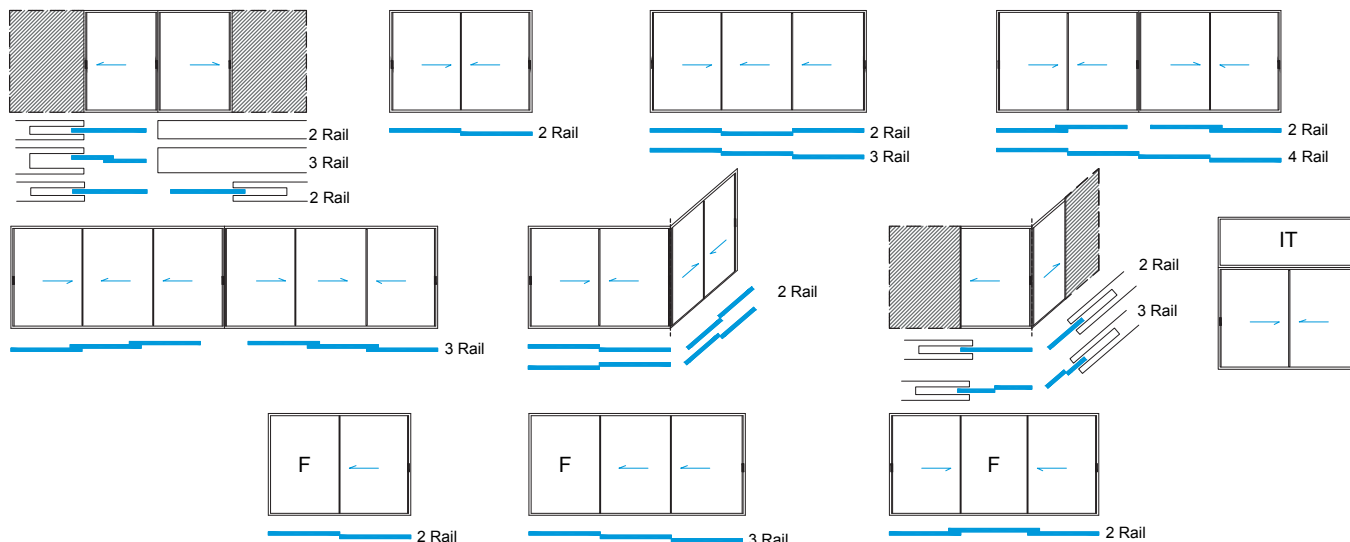

Todas as medidas são consideradas em mm, salvo as devidamente identificadas

All measurements are considered in mm, except those duly identified | Toutes les mesures sont considérées en mm saufs celles qui sont dûment identifiées.

**sistema de correr JT minimalista com corte térmico**  
**minimalist JT sliding system with thermal break**  
**système coulissant minimaliste JT à rupture de pont thermique**



Com o intuito de reduzir a vista de alumínio nas janelas, mantendo as características muito apreciadas da JT, criaram-se novos perfis móveis lateral, centrais e travessa. Através da utilização destes perfis é possível ir ao encontro de pedidos de vãos minimalistas, conseguindo também melhorias térmicas quando comparado com o sistema de perfis móveis JT tradicionais. Com os novos perfis centrais é possível ter uma vista central minimalista de apenas 20mm.

With the aim of reducing the view of aluminum on the windows, maintaining the much appreciated characteristics of the JT, new lateral, central and transom mobile profiles were created. Through the use of these profiles, it is possible to meet requests for minimalist frames, also achieving thermal improvements when compared to the classic JT mobile profile system. With the new central profiles it is possible to have a minimalist central view of just 20mm.

Dans le but de réduire la vue de l'aluminium sur les fenêtres, en conservant les caractéristiques très appréciées du JT, de nouveaux profilés mobiles latéraux, centraux et traverse ont été créés. Grâce à l'utilisation de ces profilés, il est possible de répondre aux demandes de portées minimalistes, tout en réalisant des améliorations thermiques par rapport au système de profilés mobiles JT classique. Avec les nouveaux profilés centraux, il est possible d'avoir une vue centrale minimaliste de seulement 20 mm.

**APRESENTAÇÃO**

PRESENTATION | PRÉSENTATION

Reta | Straight | Droite

**DIMENSÕES**

DIMENSIONS | DIMENSIONS

Aro fixo | Fixed frame | Cadres dormant: 2Rail: 75mm | 96mm | 108mm | 117mm | 152mm  
3Rail: 152mm | 164mm  
4Rail: 220mm | 228mm  
Aro móvel | Mobile frame | Cadres ouvrants: 40mm | 45mm

**ENCHIMENTO**

FILLING | REMPLISSAGE

De 28 a 34mm | From 28 to 34mm | De 28 à 34mm

**CORTES**

CUTS | COUPES

45° | 90°

**VEDAÇÃO**

INSULATION | ÉTANCHÉITE

Juntas em EPDM | EPDM joints | Joints en EPDM  
Pelúcias STOP-FIN | STOP-FIN brushes | Joints brosse STOP-FIN

**POLIAMIDA**

POLYAMIDE | BARRETES

14mm | 24mm | 30mm | 32mm | 36mm | 40mm

**UNIÕES**

JOINTS | UNIONS

Esquadros de bloqueio | Corner cleats | Équerres d'angle: 9,5mm | 20,5mm

**ABERTURAS**

OPENINGS | OUVERTURES

2Rail: 1, 2, 3 ou | or | ou 4 folhas | sashes | vantaux  
3Rail: 3 ou | or | ou 6 folhas | sashes | vantaux  
4Rail: 4 ou | or | ou 8 folhas | sashes | vantaux

**PESO MÁXIMO**

MAXIMUM WEIGHT | POIDS MAXIMALE

290 Kg/folha | sash | vantail

**ÁREA MÁXIMA**

MAXIMUM AREA | AIRE MAXIMALE

4,50 m<sup>2</sup>/folha | sash | vantail

**LARGURA MÁXIMA**

MAXIMUM LENGTH | LARGEUR MAXIMALE

2,00 m/folha | sash | vantail

**ALTURA MÁXIMA**

MAXIMUM HEIGHT | HAUTEUR MAXIMALE

3,00 m/folha | sash | vantail

**ACABAMENTOS**

FINISHES | FINITIONS

Lacados | Powder coated | Laqué  
Anodizados | Anodised | Anodisé  
Bicolores | Bicolour | Bicoloreur

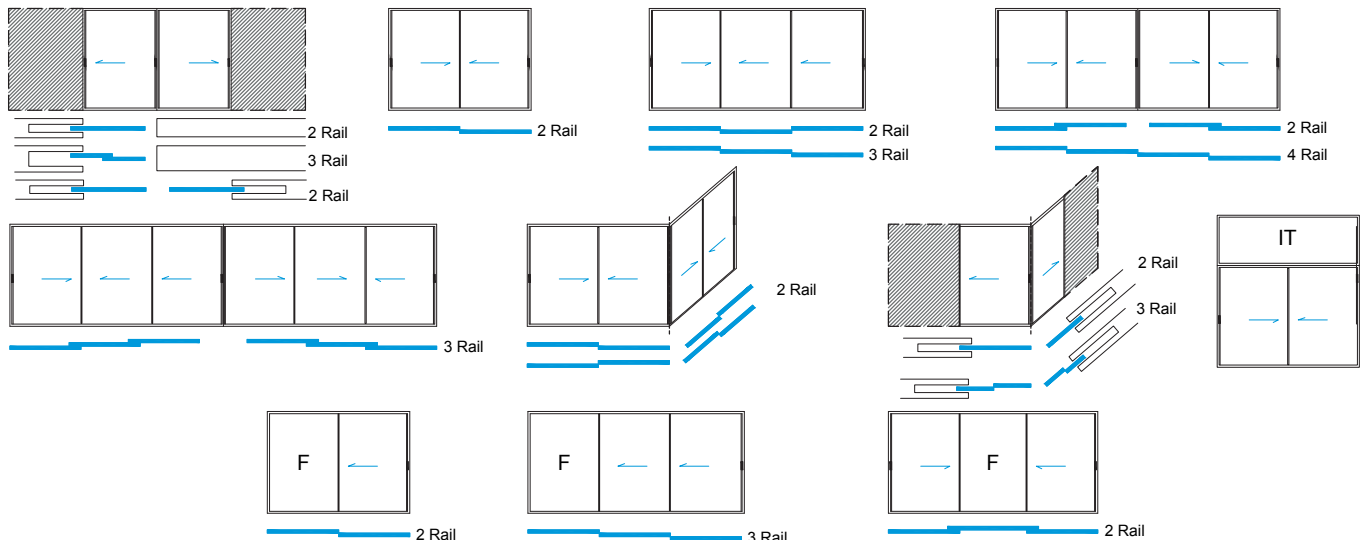

Todas as medidas são consideradas em mm, salvo as devidamente identificadas

All measurements are considered in mm, except those duly identified | Toutes les mesures sont considérées en mm saufs celles qui sont dûment identifiées.

# DESEMPENHO DO SISTEMA

system performance | performance du système

<p><b>Marcação CE</b> CE Marking Marquage CE NP EN 14351-1</p>	<p><b>Janela 2 folhas de correr JT com 2,405m x 2,295m (LxH)</b> <b>Vidro: 10 + 12 + 10</b> 2 Sliding sashes window with 2,405m x 2,295m (LxH) Glass: 10 + 12 + 10 Fenêtre coulissant 2 vantaux avec 2,405m x 2,295m (LxH) Verre: 10 + 12 + 10</p> <p>ENSAIO   TEST   ESSAIS CXL 79/20 [PT]   86/20 [EN]   87/20 [FR]</p>	<p><b>Janela 2 folhas de correr JT com 3,195m x 2,595m (LxH)</b> <b>Vidro: 10 (PVB 1,52) 8 (PVB 1,52) 10</b> 2 Sliding sashes window with 3,190m x 2,590m (LxH) Glass: 10 (PVB 1,52) 8 (PVB 1,52) 10 Fenêtre coulissant 2 vantaux avec 3,190m x 2,590m (LxH) Verre: 10 (PVB 1,52) 8 (PVB 1,52) 10</p> <p>ENSAIO   TEST   ESSAIS CXL 121/22 [PT]   124/22 [EN]   125/22 [FR]</p>
<p><b>Permeabilidade ao AR</b> AIR Permeability Permeabilité à l'AIR EN 12 207:2016</p>	<p>3</p>	<p>4</p>
<p><b>Estanquidade à ÁGUA</b> WATER Tightness Étanchéité à l'EAU EN 12 208:1999</p>	<p>7A</p>	<p>7A</p>
<p><b>Resistência ao VENTO</b> WIND Resistance Résistance au VENT EN 12 210:2016</p>	<p>C5</p>	<p>C3</p>
<p><b>Isolamento ACÚSTICO</b> ACOUSTIC Insulation Isolation ACOUSTIQUE NP EN 14351-1:2008 - Anexo B</p>	<p><b>Rw = 37 dB</b> Rw (IGU) = 47 dB, área   area ≤ 2,70m<sup>2</sup> ENSAIO   TEST   ESSAIS ACL 055/21</p>	
<p><b>Coef. Transm. TÉRMICA</b> THERMAL Transmittance Coef. Transm. THERMIQUE UNE-ISO 13947:2005</p>	<p><b>Uw = 1,37 W/m<sup>2</sup>K</b> Vidro triplo   Triple glazing   Vitrage triple Ug = 0,80 W/m<sup>2</sup>K Janela de 2 folhas com   2 Sashes window with   Fenêtre de 2 vantaux avec 2,4m x 2,3m (LxH)</p> <p><b>Uw = 1,46 W/m<sup>2</sup>K</b> Vidro duplo   Double glazing   Vitrage double Ug = 1,00 W/m<sup>2</sup>K Janela de 2 folhas com   2 Sashes window with   Fenêtre de 2 vantaux avec 3,1m x 2,5m (LxH)</p>	

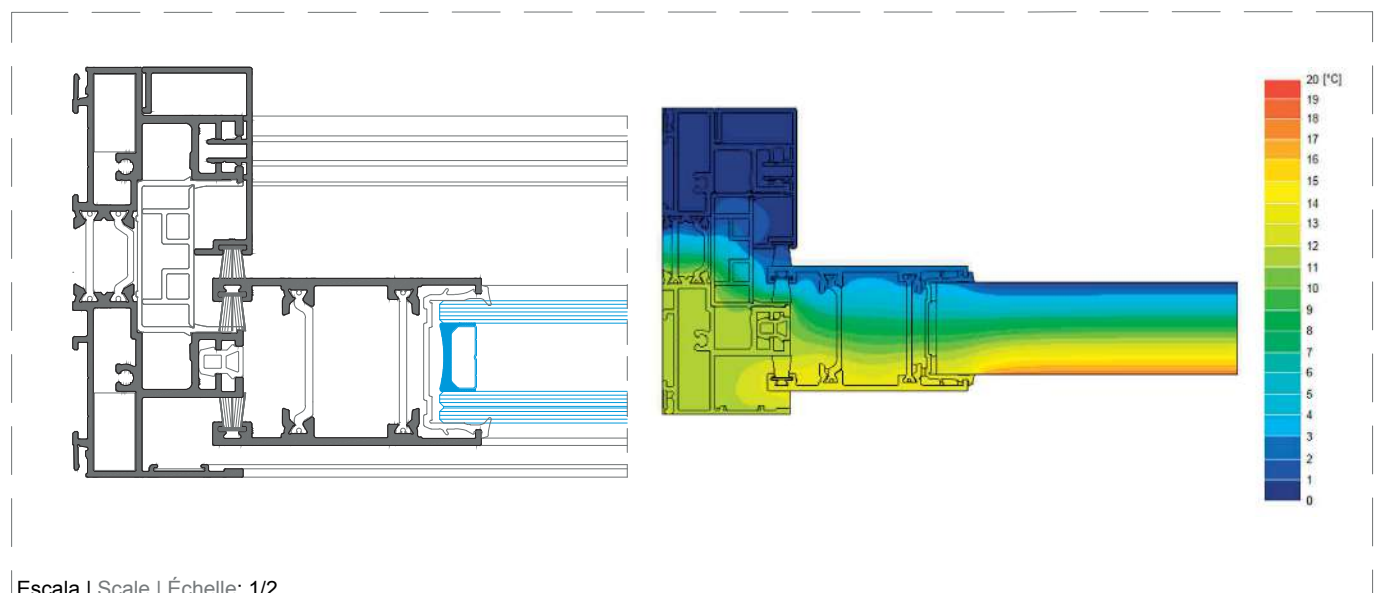

Escala | Scale | Échelle: 1/2

# DESEMPENHO DO SISTEMA

system performance | performance du système

<p><b>Marcação CE</b> CE Marking Marquage CE NP EN 14351-1</p>	<p><b>Janela 1 folha de correr ext. + fixo JT com 3,190m x 2,590m (LxH)</b> <b>Vidro: 10 + 12 + 10</b> 1 Exterior sliding sash + fixed window with 3,190m x 2,590m (LxH) Glass: 10 + 12 + 10 Fenêtre coulissant 1 vantail ext. + fixe avec 3,190m x 2,590m (LxH) Verre: 10 + 12 + 10</p> <p>ENSAIO   TEST   ESSAIS CXL 120/22 [PT]   122/22 [EN]   123/22 [FR]</p>
<p><b>Permeabilidade ao AR</b> AIR Permeability Permeabilité à l'AIR EN 12 207:2016</p>	<p>4</p>
<p><b>Estanquidade à ÁGUA</b> WATER Tightness Étanchéité à l'EAU EN 12 208:1999</p>	<p>7A</p>
<p><b>Resistência ao VENTO</b> WIND Resistance Résistance au VENT EN 12 210:2016</p>	<p>B3</p>
<p><b>Isolamento ACÚSTICO</b> ACOUSTIC Insulation Isolation ACOUSTIQUE NP EN 14351-1:2008 - Anexo B</p>	<p><b>Rw = 30 dB</b> Rw (IGU) = 36 dB, área   area ≤ 2,70m<sup>2</sup> NORMA PORTUGUESA   PORTUGUESE STANDARD   NORME PORTUGAISE NP EN 14351-1 2008</p>
<p><b>Coef. Transm. TÉRMICA</b> THERMAL Transmittance Coef. Transm. THERMIQUE UNE-ISO 13947:2005</p>	<p><b>Uw = 1,37 W/m<sup>2</sup>K</b> Vidro triplo   Triple glazing   Vitrage triple Ug = 0,80 W/m<sup>2</sup>K Janela de 2 folhas com   2 Sashes window with   Fenêtre de 2 vantaux avec 2,4m x 2,3m (LxH)</p> <p><b>Uw = 1,47 W/m<sup>2</sup>K</b> Vidro duplo   Double glazing   Vitrage double Ug = 1,00 W/m<sup>2</sup>K Janela de 2 folhas com   2 Sashes window with   Fenêtre de 2 vantaux avec 3,1m x 2,5m (LxH)</p>

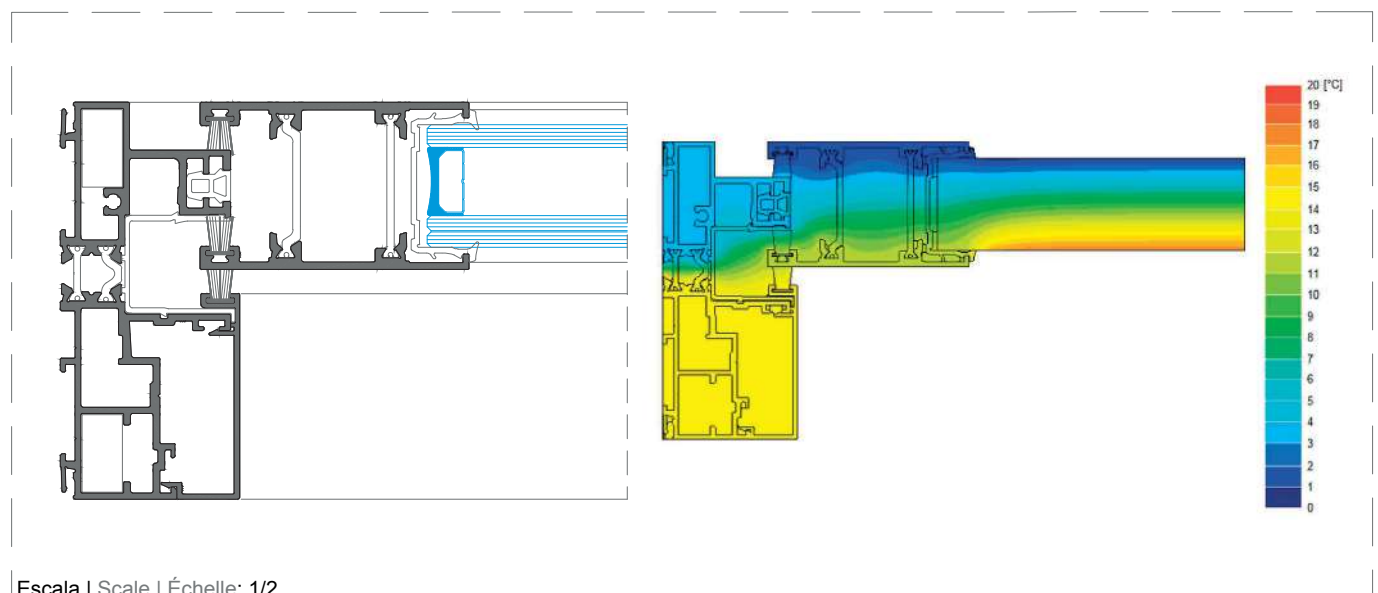

Escala | Scale | Échelle: 1/2

# DESEMPENHO DO SISTEMA

system performance | performance du système

<p><b>Marcação CE</b> CE Marking Marquage CE NP EN 14351-1</p>	<p><b>Janela 1 folha de correr int. + fixo JT com 3,190m x 2,590m (LxH)</b> <b>Vidro: 10 + 12 + 10</b> Window with one sliding sash and a fixed leaf with 3,190m x 2,590m (LxH) Glass: 10 + 12 + 10 Fenêtre avec un vantail coulissant et un vantail fixe avec 3,190m x 2,590m (LxH) Verre: 10 + 12 + 10</p> <p>ENSAIO   TEST   ESSAIS CXL 36/23 [PT]   37/23 [EN]   38/23 [FR]</p>	<p><b>Janela 1 folha de correr int. + fixo JT com 3,190m x 2,590m (LxH)</b> <b>Vidro: 10 + 12 + 10</b> Window with one sliding sash and a fixed leaf with 3,190m x 2,590m (LxH) Glass: 10 + 12 + 10 Fenêtre avec un vantail coulissant et un vantail fixe avec 3,190m x 2,590m (LxH) Verre: 10 + 12 + 10</p> <p>ENSAIO   TEST   ESSAIS CXL 39/23 [PT]   40/23 [EN]   41/23 [FR]</p>
<p><b>Permeabilidade ao AR</b> AIR Permeability Permeabilité à l'AIR EN 12 207:2016</p>	<p>4</p>	<p>4</p>
<p><b>Estanquidade à ÁGUA</b> WATER Tightness Étanchéité à l'EAU EN 12 208:1999</p>	<p>7A</p>	<p>7A</p>
<p><b>Resistência ao VENTO</b> WIND Resistance Résistance au VENT EN 12 210:2016</p>	<p>B4</p>	<p>C3</p>
<p><b>Isolamento ACÚSTICO</b> ACOUSTIC Insulation Isolation ACOUSTIQUE NP EN 14351-1:2008 - Anexo B</p>	<p><b>Rw = 30 dB</b> Rw (IGU) = 36 dB, área   area ≤ 2,70m<sup>2</sup> NORMA PORTUGUESA   PORTUGUESE STANDARD   NORME PORTUGAISE NP EN 14351-1 2008</p>	
<p><b>Coef. Transm. TÉRMICA</b> THERMAL Transmittance Coef. Transm. THERMIQUE UNE-ISO 13947:2005</p>	<p><b>Uw = 1,38 W/m<sup>2</sup>K</b> Vidro triplo   Triple glazing   Vitrage triple Ug = 0,80 W/m<sup>2</sup>K Janela de 2 folhas com   2 Sashes window with   Fenêtre de 2 vantaux avec 2,4m x 2,3m (LxH)</p> <p><b>Uw = 1,48 W/m<sup>2</sup>K</b> Vidro duplo   Double glazing   Vitrage double Ug = 1,00 W/m<sup>2</sup>K Janela de 2 folhas com   2 Sashes window with   Fenêtre de 2 vantaux avec 3,1m x 2,5m (LxH)</p>	

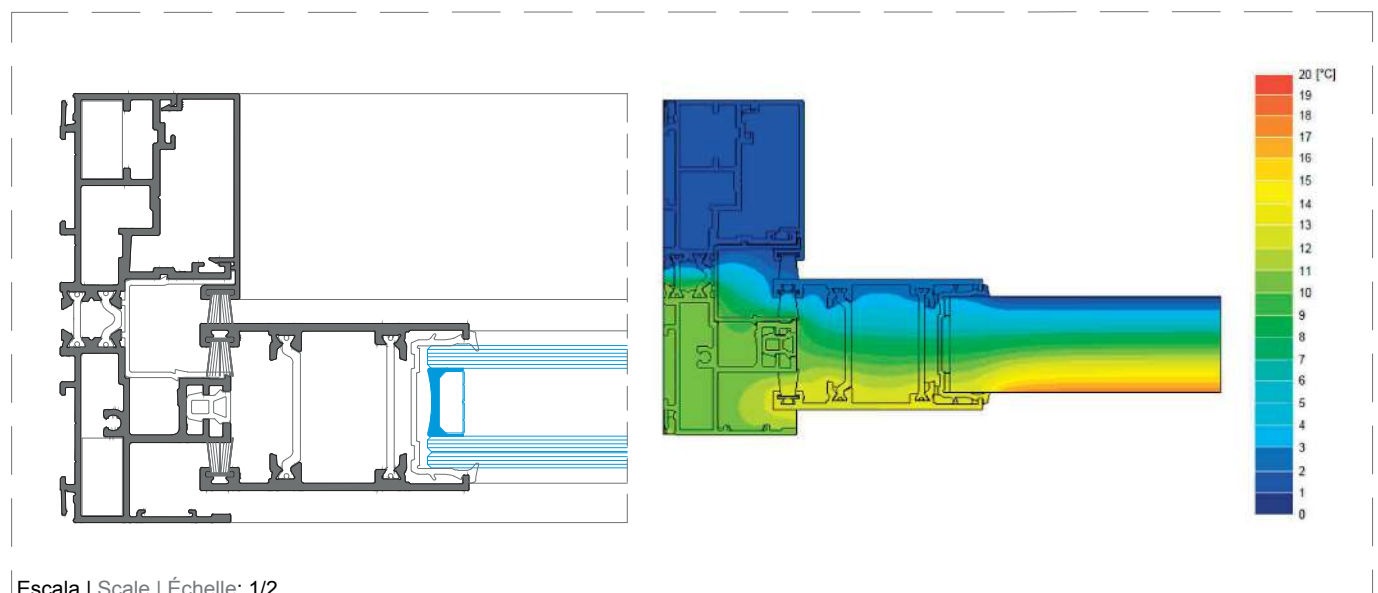

Escala | Scale | Échelle: 1/2



## DESEMPENHO DO SISTEMA

system performance | performance du système

<p><b>Marcação CE</b> CE Marking Marquage CE NP EN 14351-1</p>	<p><b>Janela 2 folhas de correr JT-Slim com 3,190m x 2,600m (LxH)</b> <b>Vidro: 10 + 12 + 10</b> 2 Sliding sashes window with 3,190m x 2,600m (LxH) Glass: 10 + 12 + 10 Fenêtre coulissant 2 vantaux avec 3,190m x 2,600m (LxH) Verre: 10 + 12 + 10</p> <p>ENSAIO   TEST   ESSAIS CXL 94/23 [PT]   95/23 [EN]   96/23 [FR]</p>	<p><b>Janela 2 folhas de correr JT-Slim com 3,190m x 2,600m (LxH)</b> <b>Vidro: 10 + 12 + 10</b> 2 Sliding sashes window with 3,190m x 2,600m (LxH) Glass: 10 + 12 + 10 Fenêtre coulissant 2 vantaux avec 3,190m x 2,600m (LxH) Verre: 10 + 12 + 10</p> <p>ENSAIO   TEST   ESSAIS CXL 97/23 [PT]   98/23 [EN]   99/23 [FR]</p>
<p><b>Permeabilidade ao AR</b> AIR Permeability Permeabilité à l'AIR EN 12 207:2016</p>	<p>4</p>	<p>4</p>
<p><b>Estanquidade à ÁGUA</b> WATER Tightness Étanchéité à l'EAU EN 12 208:1999</p>	<p>7A</p>	<p>7A</p>
<p><b>Resistência ao VENTO</b> WIND Resistance Résistance au VENT EN 12 210:2016</p>	<p>C3</p>	<p>B4</p>
<p><b>Isolamento ACÚSTICO</b> ACOUSTIC Insulation Isolation ACOUSTIQUE NP EN 14351-1:2008 - Anexo B</p>	<p><b>Rw = 37 dB</b> Rw (IGU) = 47 dB, área   area ≤ 2,70m<sup>2</sup> ENSAIO   TEST   ESSAIS ACL 055/21</p>	
<p><b>Coef. Transm. TÉRMICA</b> THERMAL Transmittance Coef. Transm. THERMIQUE UNE-ISO 13947:2005</p>	<p><b>Uw = 1,34 W/m<sup>2</sup>K</b> Vidro triplo   Triple glazing   Vitrage triple Ug = 0,80 W/m<sup>2</sup>K Janela de 2 folhas com   2 Sashes window with   Fenêtre de 2 vantaux avec 2,4m x 2,3m (LxH)</p> <p><b>Uw = 1,44 W/m<sup>2</sup>K</b> Vidro duplo   Double glazing   Vitrage double Ug = 1,00 W/m<sup>2</sup>K Janela de 2 folhas com   2 Sashes window with   Fenêtre de 2 vantaux avec 3,1m x 2,5m (LxH)</p>	

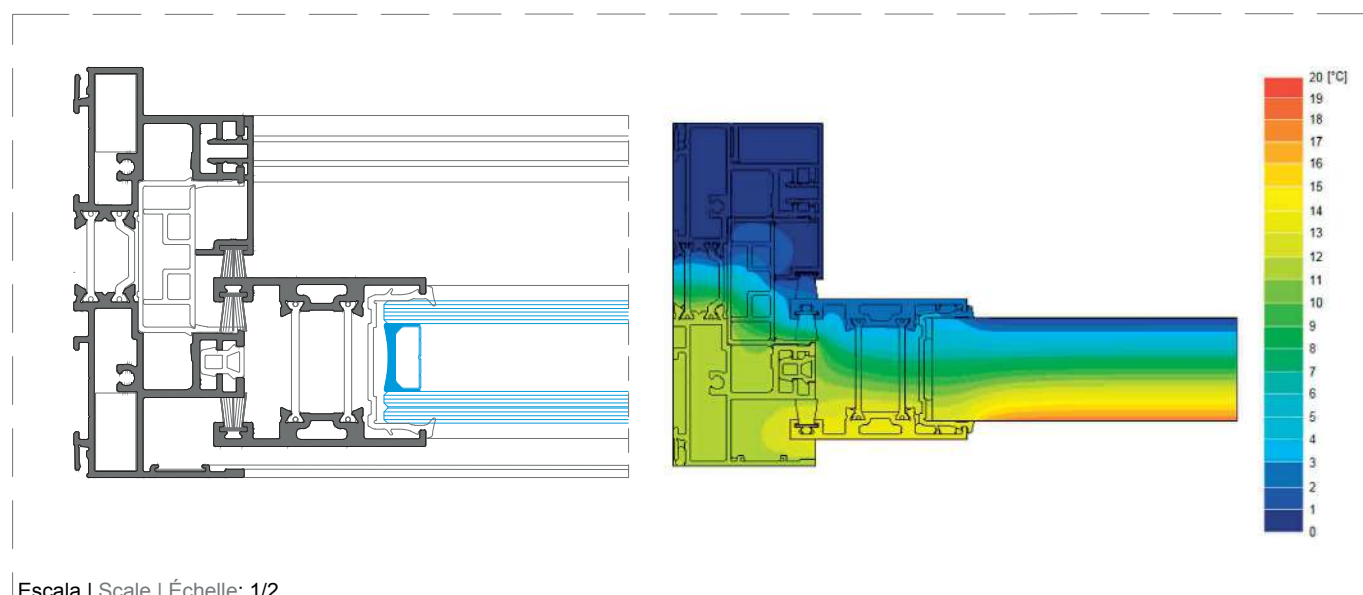

Escala | Scale | Échelle: 1/2

# DESEMPENHO DO SISTEMA

system performance | performance du système

## Janela 2 folhas de correr JT com 3,190m x 2,590m (LxH)

### Vidro laminado: 10.8.10 [e=29.52mm]

2 Sliding sashes window with 3,190m x 2,590m (LxH)

Laminated glass: 10.8.10 [e=29.52mm]

Fenêtre coulissant 2 vantaux avec 3,190m x 2,590m (LxH)

Verre feuilleté: 10.8.10 [e=29.52mm]

**ENSAIO | TEST | ESSAIS**  
**CXL 033/21 [PT] | 34/21 [EN]**

### Determinação da resistência a abertura e fecho repetidos de janelas (EN 1191:2012; EN 12400:2002)

Resistance to repeated opening and closing of windows  
Résistance à l'ouverture et à la fermeture répétées des fenêtres

#### Condições atmosféricas

Atmospheric conditions | Conditions atmosphériques

Temperatura Temperature   Température	19.1 °C
Humidade relativa Relative humidity   Humidité relative	50.4%

#### Resultados Results | Résultats

Massa da folha ensaiada Mass of the moving component   Masse de l'élément mobile	284.2 Kg	
Peso próprio do sistema aplicado Dead load of the applied system   Poids propre du système appliqué	39.2 N	
Durabilidade mecânica Relative humidity   Humidité relative	Classe Class   Classe	Serviço Class   Classe
	3 (20.000 ciclos) (cycles  cycles)	Pesado Heavy   Lourd

### Determinação das forças de manobra de janelas (EN 12046-1:2003; EN 13115:2001)

Determination of the operating forces of windows  
Détermination des forces de manœuvre des fenêtres

Ensaio Test   Essai	Classe Class   Classe
Libertação da ferragem Disengage hardware   Désengagement du matériel	2
Abertura da folha Commence opening   Début de l'ouverture	1
Fecho da folha Commence closing   Début de la fermeture	1
Acionamento da ferragem Engage hardware   Activation du matériel	2

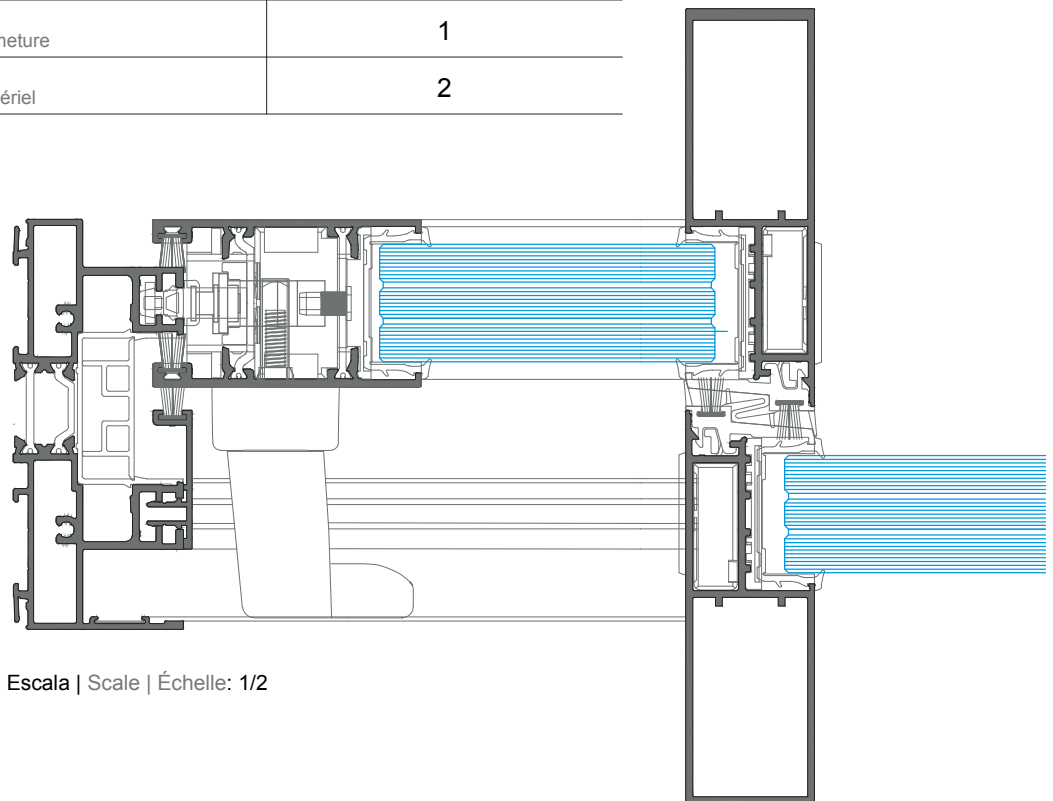

Escala | Scale | Échelle: 1/2



**LISTAGEM DE PERFIS**  
**PROFILES LIST | LISTE DES PROFILÉS**

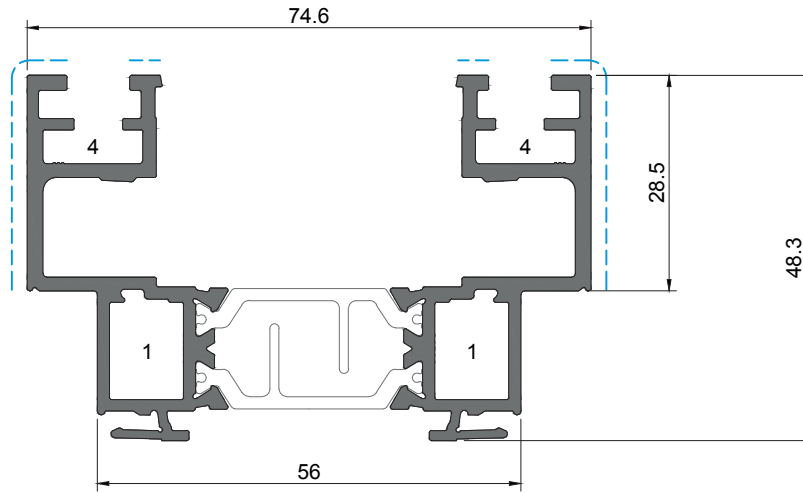

**JT 01**  
Aro fixo FR 2rail  
2rail FR fixed frame | Cadre dormant FR 2rail

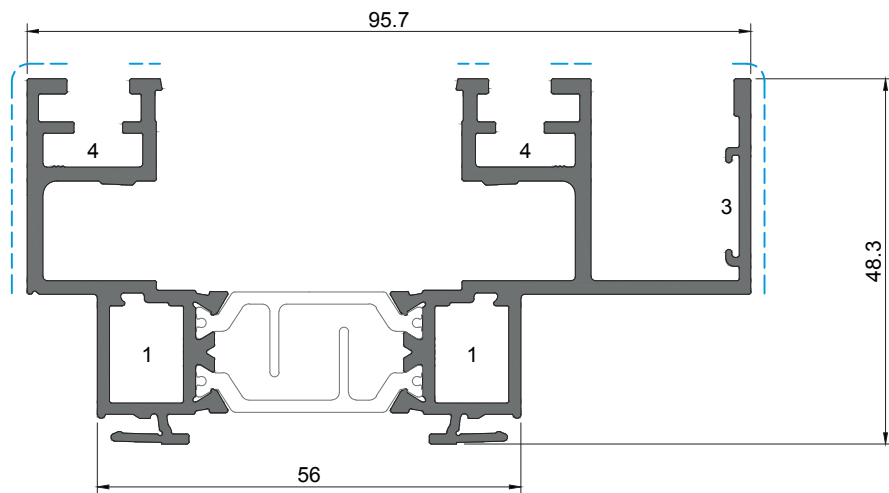

**JT 02**  
Aro fixo FR 2rail  
2rail FR fixed frame | Cadre dormant FR 2rail

Treatmento de superficie | Surface treatment | Traitement de surface  
PB | PPM | EF | EM  
PB | PPM | EF | EM  
Para mais informações, consultar Catálogo de Cores Anodizadas  
For further information, consult the Anodised Colours Catalogue | Pour plus d'informations, veuillez consulter le Catalogue des Couleurs Anodisées

1 - ESQUADRO | CORNER CLEAT | ÉQUERRE 12x9.5 JT  
3 - CANTO | CORNER | ANGLE CR S/SB

2 - ESQUADRO | CORNER CLEAT | ÉQUERRE 11x20.5 JT  
4 - CANTO ALINHAMENTO | ALIGNMENT CORNER | ANGLE D'ALIGNEMENT JT

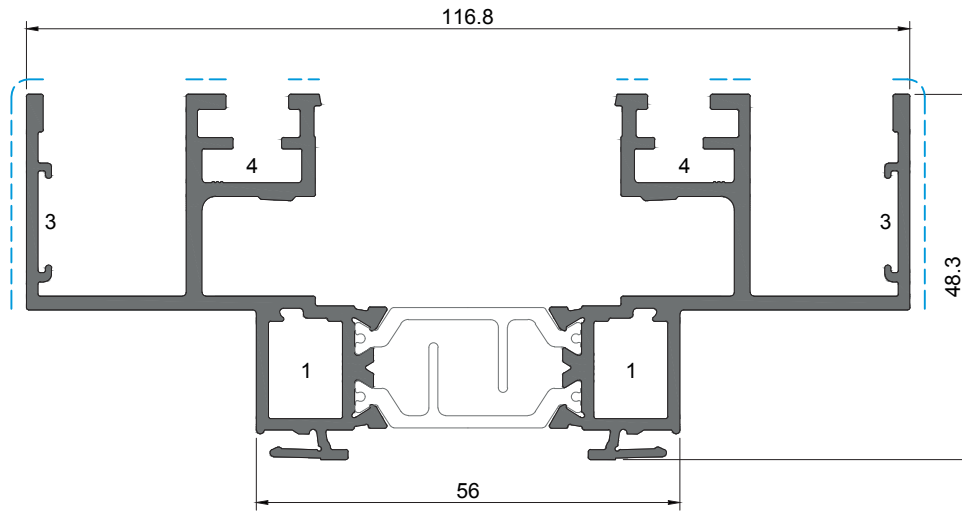

**JT 04**  
Aro fixo FR 2rail  
2rail FR fixed frame | Cadre dormant FR 2rail

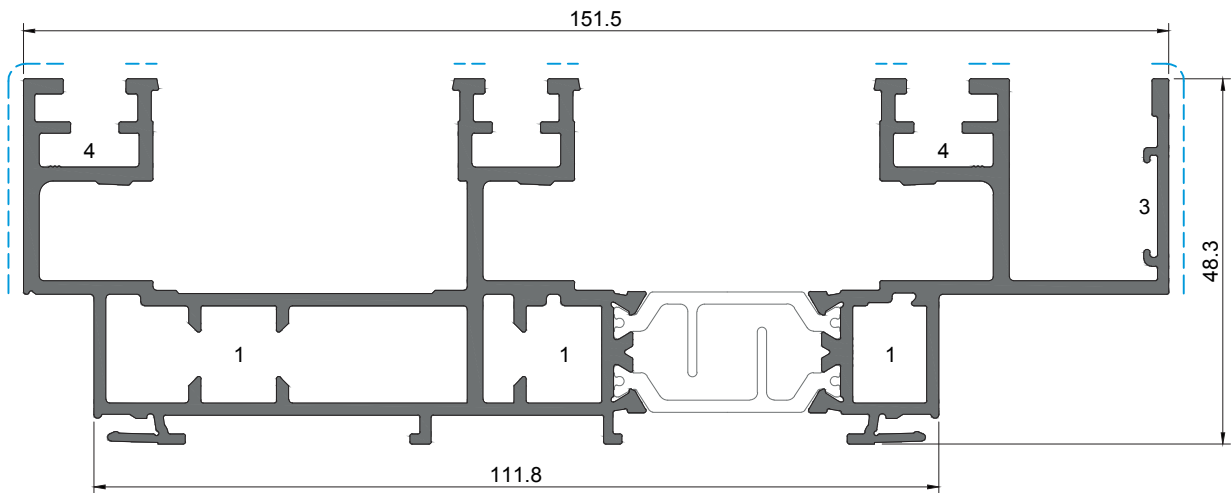

**JT 03**  
Aro fixo FR 3rail  
3rail FR fixed frame | Cadre dormant FR 3rail

Treatmento de superficie | Surface treatment | Traitement de surface  
PB | PPM | TEF | IEM  
Para mais informações, consultar Catálogo de Cores Anodizadas  
For further information, consult the Anodised Colours Catalogue | Pour plus d'informations, veuillez consulter le Catalogue des Couleurs Anodisées

1 - ESQUADRO | CORNER CLEAT | ÉQUERRE 12x9.5 JT  
3 - CANTO | CORNER | ANGLE CR S/SB

2 - ESQUADRO | CORNER CLEAT | ÉQUERRE 11x20.5 JT  
4 - CANTO ALINHAMENTO | ALIGNMENT CORNER | ANGLE D'ALIGNEMENT JT



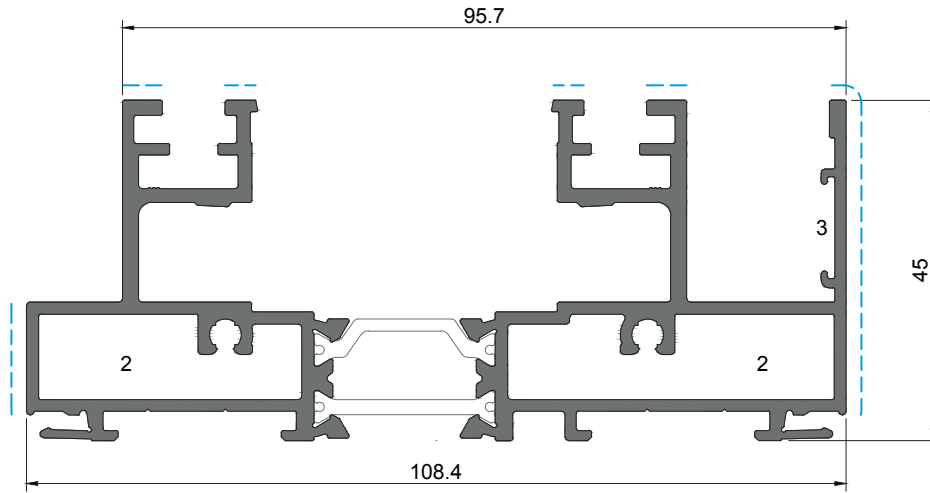

**JT 12**  
Aro fixo PT/90° 2rail  
2rail PT/90° fixed frame | Cadre dormant PT/90° 2rail

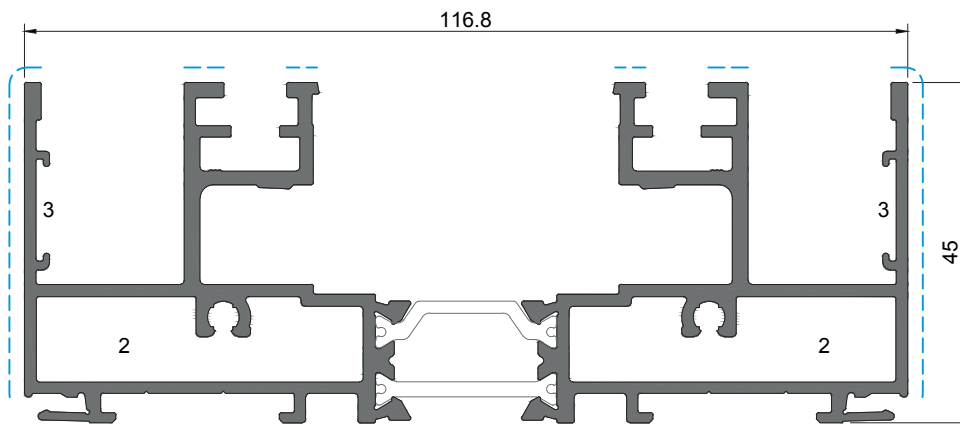

**JT 14**  
Aro fixo PT/90° 2rail  
2rail PT/90° fixed frame | Cadre dormant PT/90° 2rail

Treatmento de superficie | Surface treatment | Traitement de surface  
PB | PPM | EF | EM  
PB | PPM | EF | EM

Para mais informações, consultar Catálogo de Cores Anodizadas  
For further information, consult the Anodised Colours Catalogue | Pour plus d'informations, veuillez consulter le Catalogue des Couleurs Anodisées

1 - ESQUADRO | CORNER CLEAT | ÉQUERRE 12x9.5 JT  
3 - CANTO | CORNER | ANGLE CR S/SB

2 - ESQUADRO | CORNER CLEAT | ÉQUERRE 11x20.5 JT  
4 - CANTO ALINHAMENTO | ALIGNMENT CORNER | ANGLE D'ALIGNEMENT JT

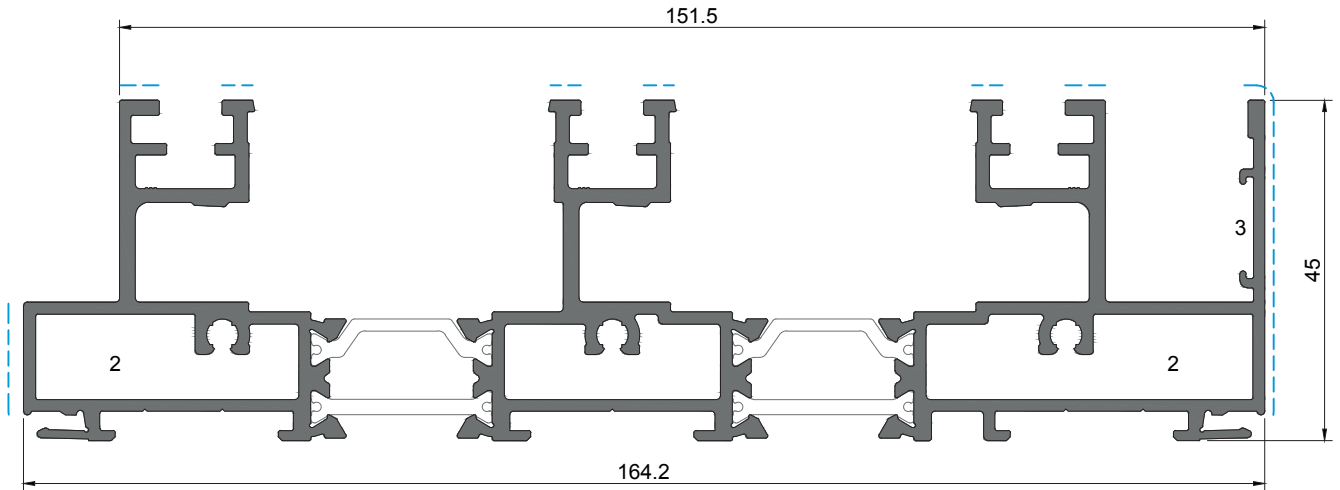

**JT 13**  
Aro fixo PT/90° 3rail  
3rail PT/90° fixed frame | Cadre dormant PT/90° 3rail

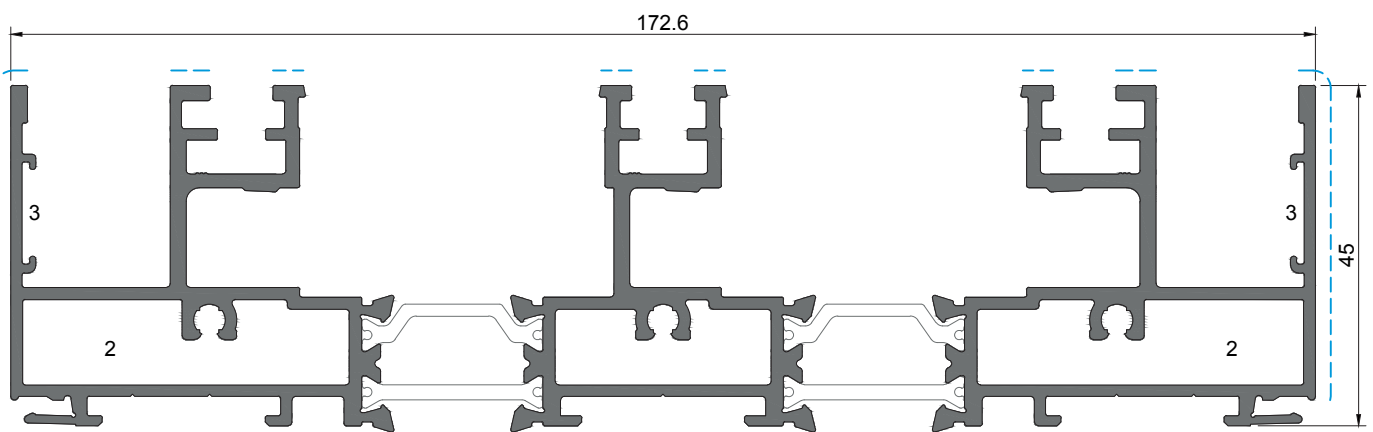

**JT 24**  
Aro fixo PT/90° 3rail  
3rail PT/90° fixed frame | Cadre dormant PT/90° 3rail

Tratamento de superfície | Surface treatment | Traitement de surface  
 PB | PPM | EFM | EFM  
 Para mais informações, consultar Catálogo de Cores Anodizadas  
 For further information, consult the Anodised Colours Catalogue | Pour plus d'informations, veuillez consulter le Catalogue des Couleurs Anodisées

1 - ESQUADRO | CORNER CLEAT | ÉQUERRE 12x9.5 JT  
3 - CANTO | CORNER | ANGLE CR S/SB

2 - ESQUADRO | CORNER CLEAT | ÉQUERRE 11x20.5 JT  
4 - CANTO ALINHAMENTO | ALIGNMENT CORNER | ANGLE D'ALIGNEMENT JT

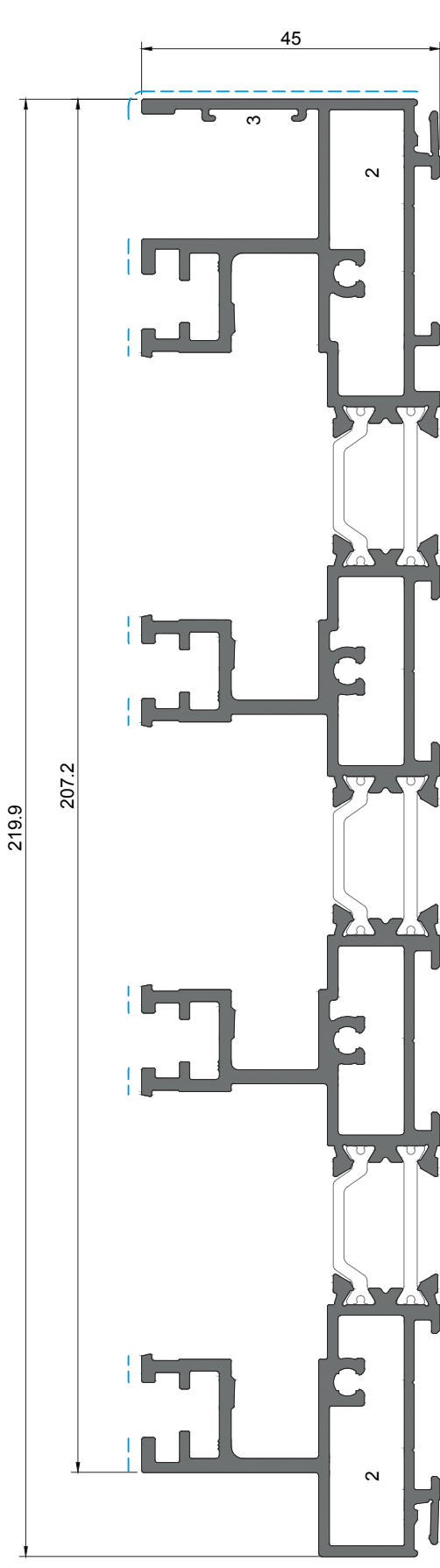

**JT 33**

Aro fixo PT/90° 4rail

4rail PT/90° fixed frame | Cadre dormant PT/90° 4rail

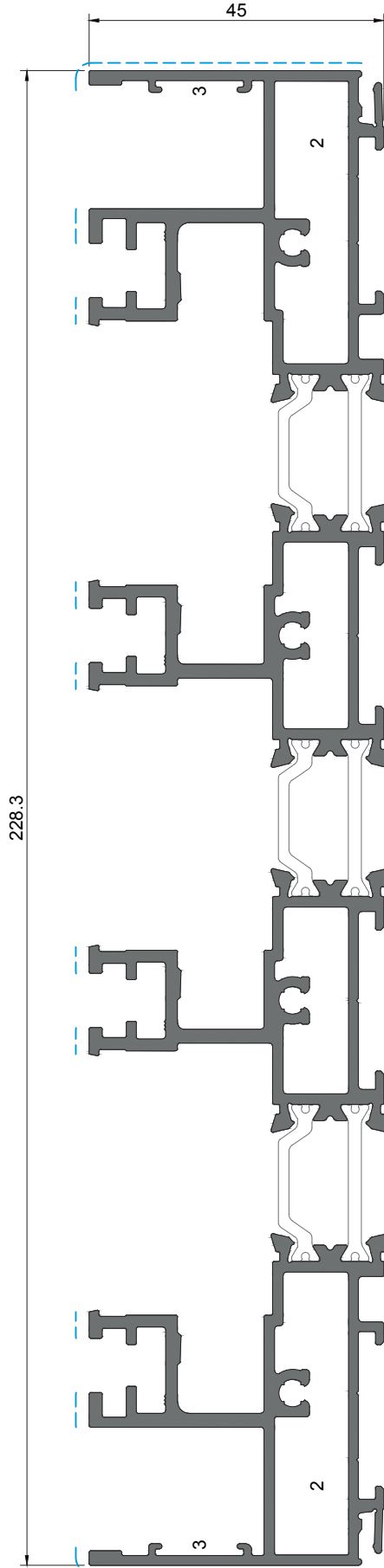

**JT 34**

Aro fixo PT/90° 4rail

4rail PT/90° fixed frame | Cadre dormant PT/90° 4rail

1 - ESQUADRO | CORNER CLEAT | ÉQUERRE 12x9.5 JT  
3 - CANTO | CORNER | ANGLE CR S/SB

2 - ESQUADRO | CORNER CLEAT | ÉQUERRE 11x20.5 JT  
4 - CANTO ALINHAMENTO | ALIGNMENT CORNER | ANGLE D'ALIGNEMENT JT

LINHA SOLEIRA 30MM | 30MM SILL LINE | LIGNE SEUIL 30MM

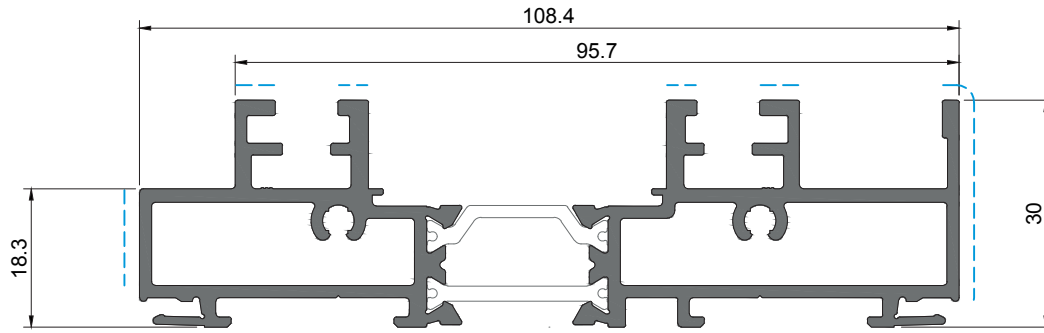

**JT 22**  
Soleira 30mm 90° 2rail  
2rail 30mm 90° sill | Seuil 30mm 90° 2rail

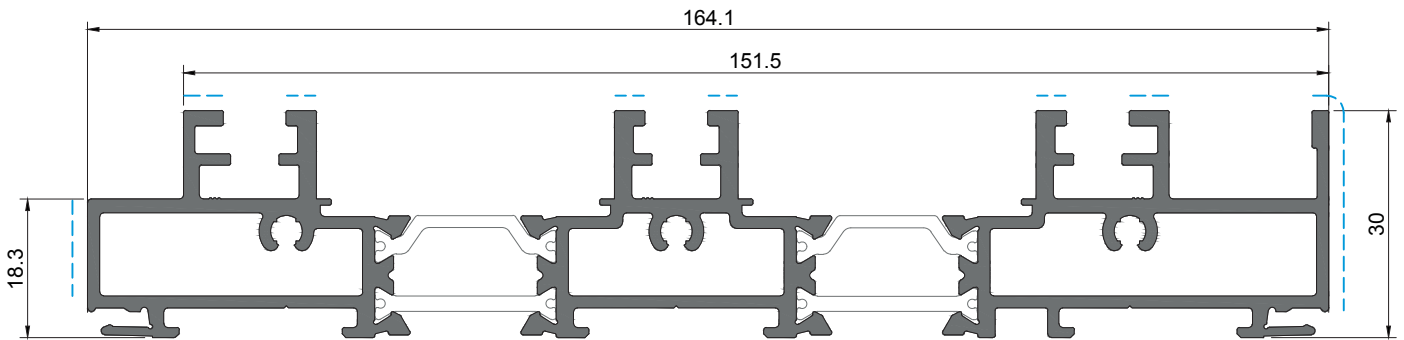

**JT 23**  
Soleira 30mm 90° 3rail  
3rail 30mm 90° sill | Seuil 30mm 90° 3rail

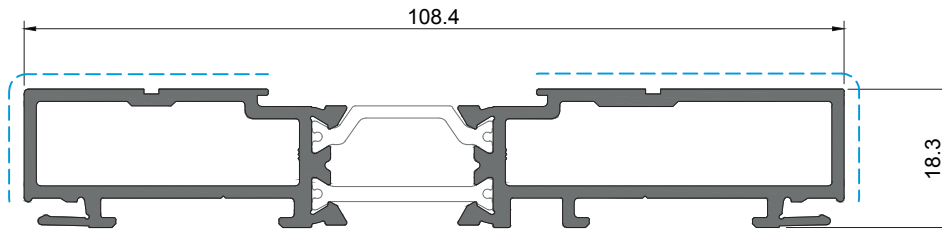

**JT 18**  
Ombreira 90° 2rail  
2rail 90° jamb | Jambage 90° 2rail

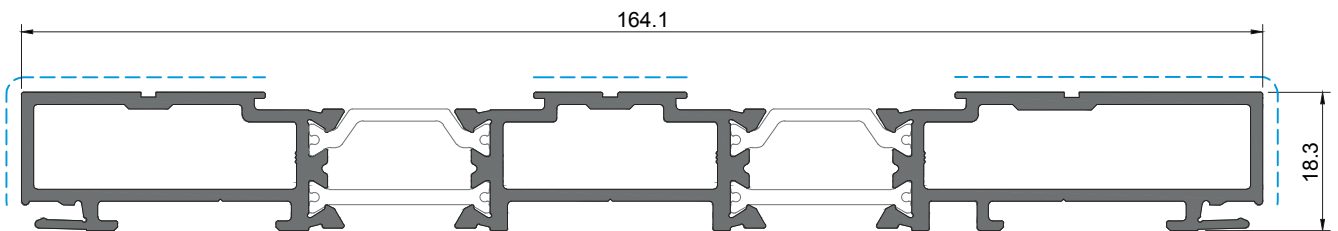

**JT 28**  
Ombreira 90° 3rail  
3rail 90° jamb | Jambage 90° 3rail

Treatmento de superficie | Surface treatment | Traitement de surface  
PB | PPM | EF | EM  
Para mais informações, consultar Catalogo de Cores Anodizadas  
For further information, consult the Anodised Colours Catalogue | Pour plus d'informations, veuillez consulter le Catalogue des Couleurs Anodisées

LINHA SOLEIRA 30MM | 30MM SILL LINE | LIGNE SEUIL 30MM

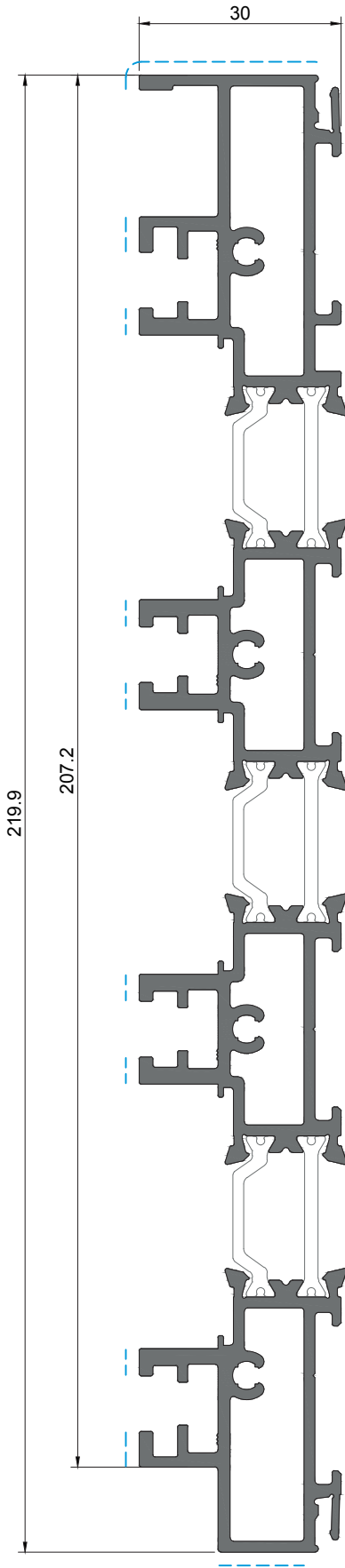

**JT 43**

**Soleira 30mm 90° 4rail**

4rail 30mm 90° sill | Seuil 30mm 90° 4rail

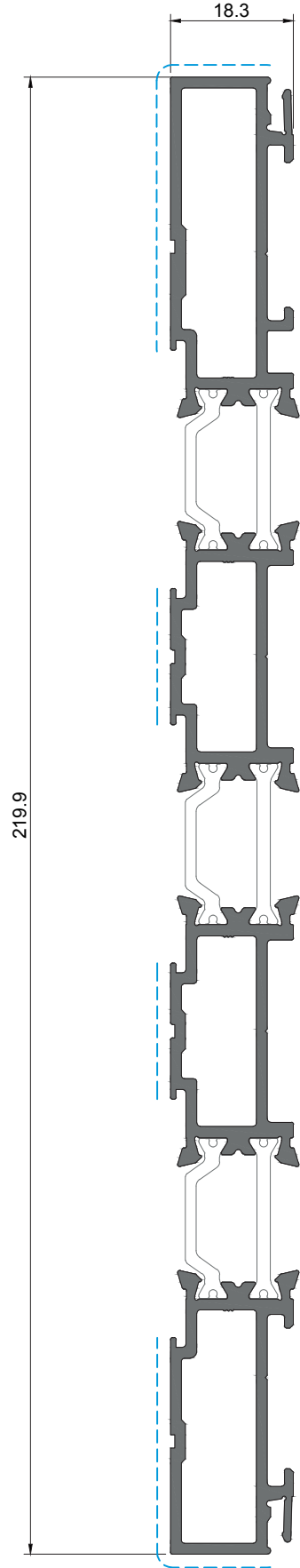

**JT 38**

**Ombreira 90° 4rail**

4rail 90° jamb | Jambage 90° 4rail



LINHA SOLEIRA 30MM | 30MM SILL LINE | LIGNE SEUIL 30MM

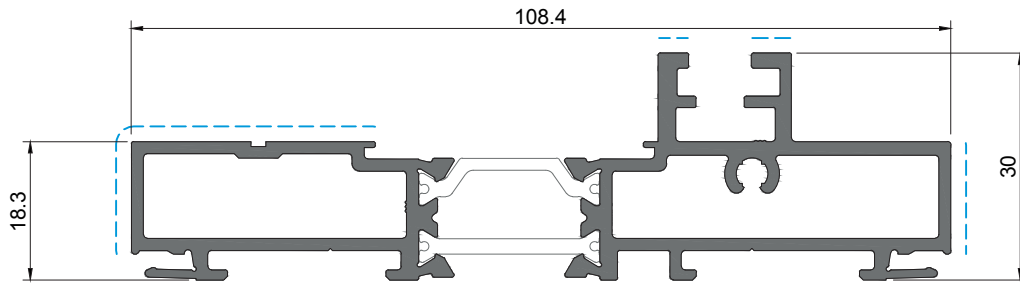

**JT 17**  
Ombreira 90° 2rail  
2rail 90° jamb | Jambage 90° 2rail

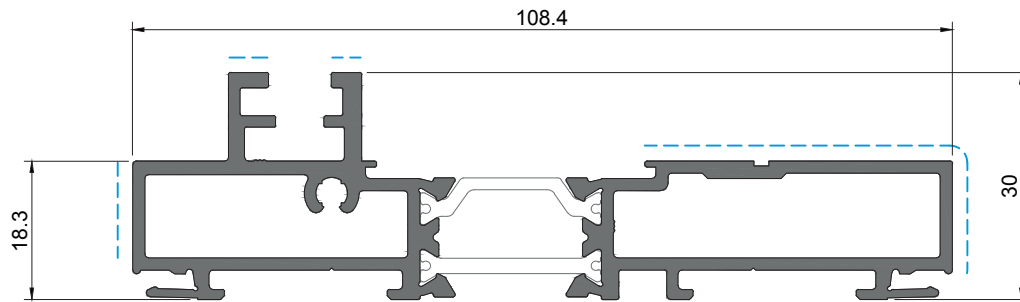

**JT 19**  
Ombreira 90° 2rail  
2rail 90° jamb | Jambage 90° 2rail

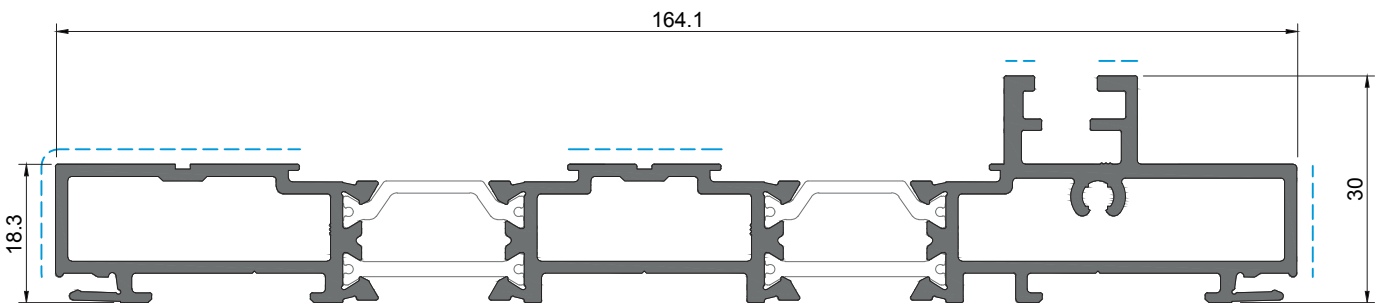

**JT 27**  
Ombreira 90° 3rail  
3rail 90° jamb | Jambage 90° 3rail

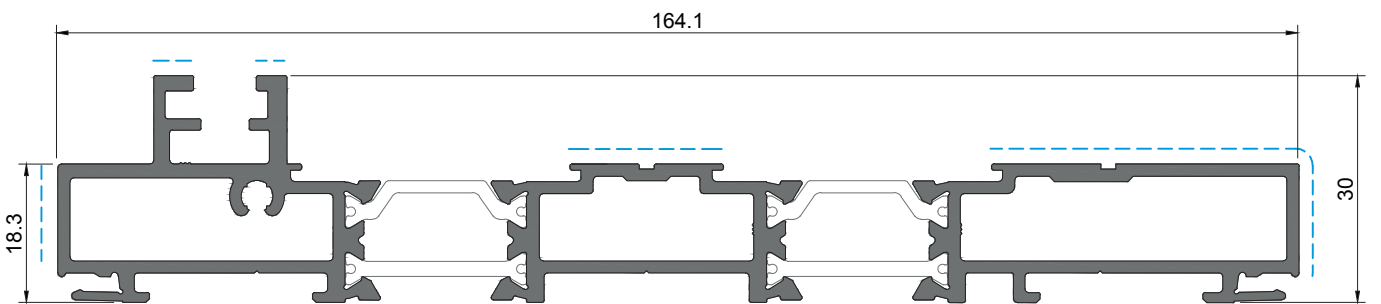

**JT 29**  
Ombreira 90° 3rail  
3rail 90° jamb | Jambage 90° 3rail

Tratamento de superfície | Surface treatment | Traitement de surface  
 PB | PM | EF | EM      PB | EF | EM  
 Para mais informações, consultar Catálogo de Cores Anodizadas  
 For further information, consult the Anodised Colours Catalogue | Pour plus d'informations, veuillez consulter le Catalogue des Couleurs Anodisées

LINHA SOLEIRA 30MM | 30MM SILL LINE | LIGNE SEUIL 30MM

Treatmento de superficie | Surface treatment | Traitement de surface  
 PB | PFM | EF | EM  
 Para mais informações, consultar **Catálogo de Cores Anodizadas**  
 For further information, consult the Anodised Colours Catalogue | Pour plus d'informations, veuillez consulter le Catalogue des Couleurs Anodisées

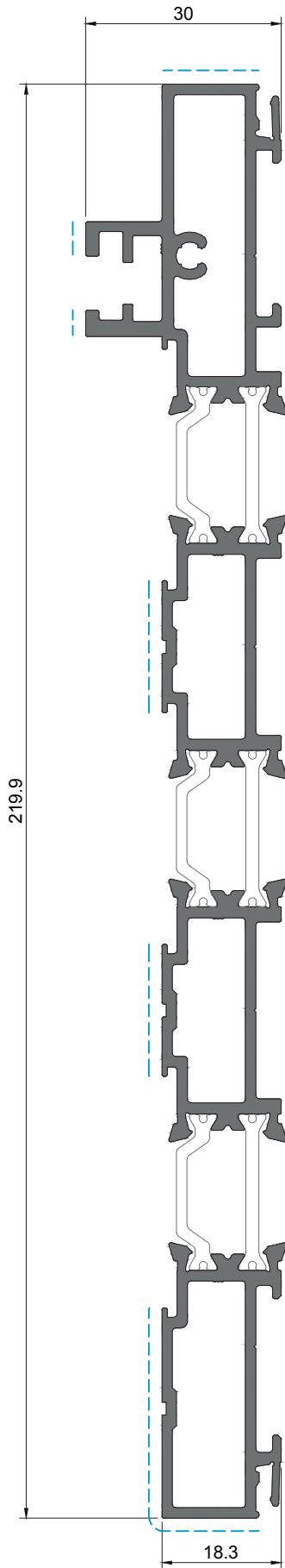

**JT 37**  
 Ombreira 90° 4rail  
 4rail 90° jamb | Jambage 90° 4rail

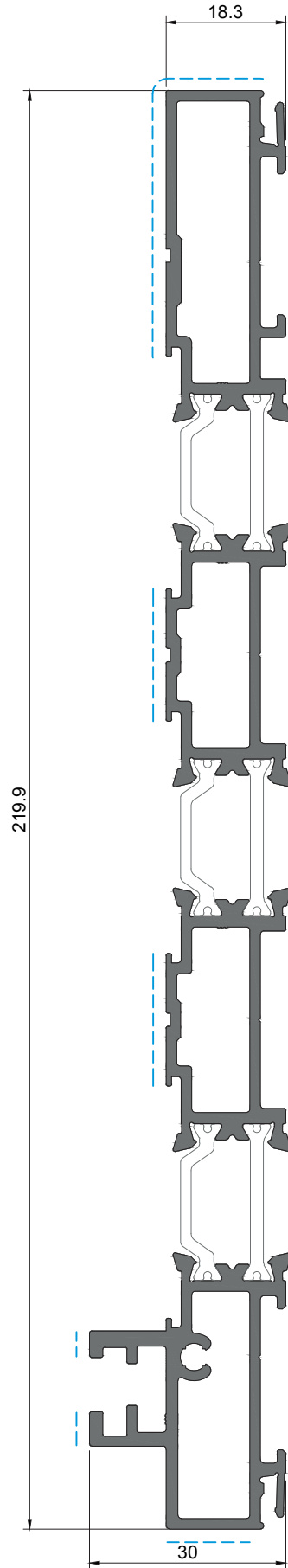

**JT 39**  
 Ombreira 90° 4rail  
 4rail 90° jamb | Jambage 90° 4rail

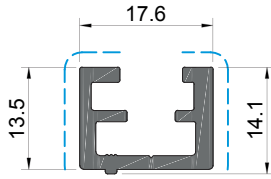

**JT 78**

Guia da ombreira 90°  
90° Jamb guide profile | Guide pour jambage 90°  
**Rails interior e exterior**  
Inside and outside rails | Rails intérieur et extérieur

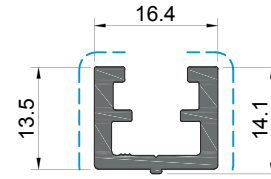

**JT 79**

Guia da ombreira 90°  
90° Jamb guide profile | Guide pour jambage 90°  
**Rail central**  
Central rail | Rail central

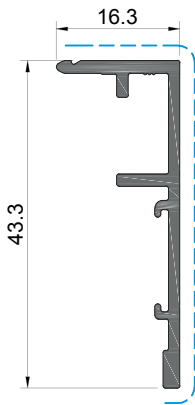

**JT 82**

Perfil pingadeira  
Drip profile | Larmier

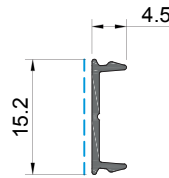

**AT 30**

Capa  
Cover | Capot

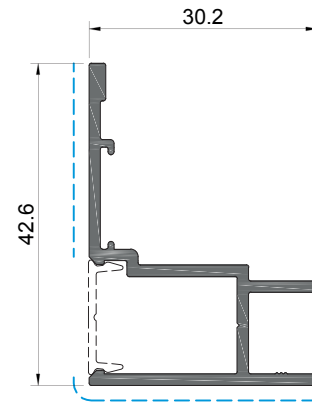

**JT 83**

Perfil pingadeira  
Drip profile | Larmier

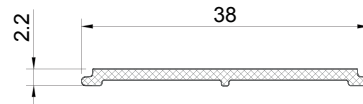

**JE 96**

Perfil poliamida  
Polyamide profile | Profilé de polyamide

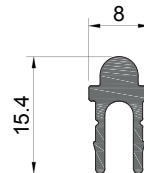

**JT 87**

Guia  
Guide | Guide

Acabamentos: Anodizado natural ou preto  
Finishings: Natural or black anodised  
Finitions: Anodisé naturel ou noir

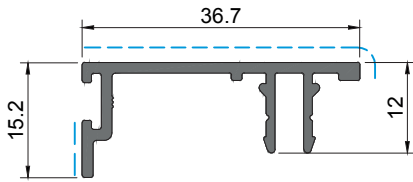

**JT 85**  
Capa  
Cover | Capot

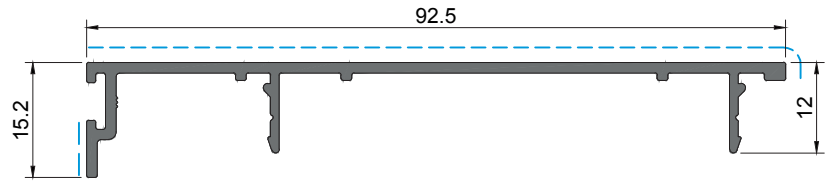

**JT 88**  
Capa  
Cover | Capot

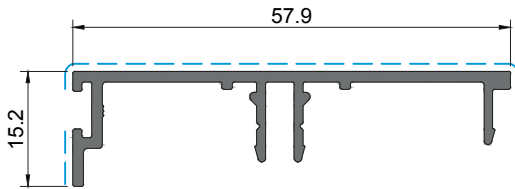

**JT 90**  
Capa  
Cover | Capot

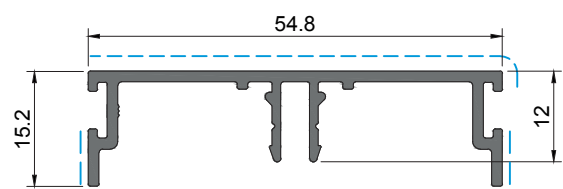

**JT 86**  
Capa  
Cover | Capot

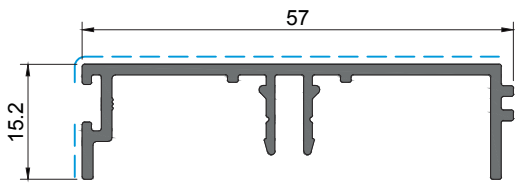

**JT 91**  
Capa  
Cover | Capot

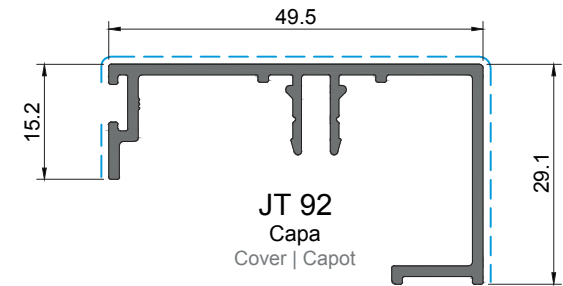

**JT 92**  
Capa  
Cover | Capot

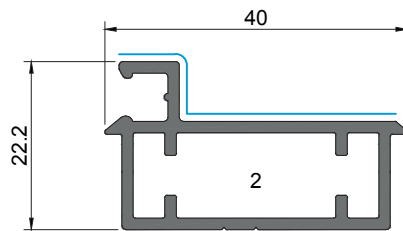

**JT 47**  
Perfil para mosquiteira  
Mosquito net profile | Profilé pour mosquitaire

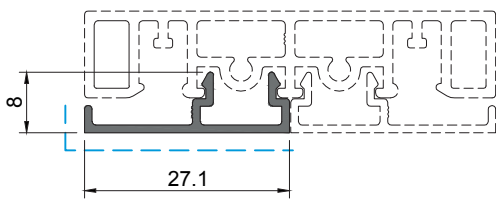

**KY 87**  
Tampa travessa rede mosquiteira  
Mosquito net transom cover | Bouchon pour traverse pour mosquitaire

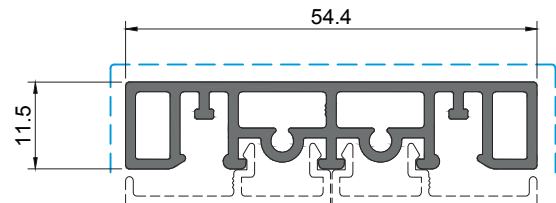

**KY 89**  
Travessa central rede mosquiteira  
Mosquito net central transom | Traverse centrale pour mosquitaire

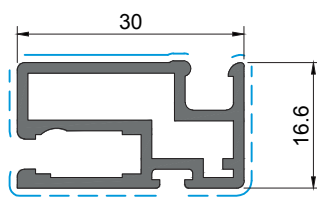

**KY 88**  
Aro móvel mosquiteira  
Mosquito net mobile frame | Cadre ouvrant mosquitaire

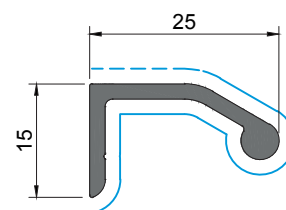

**TR 81**  
Puxador mosquiteira  
Mosquito net handle | Poignée mosquitaire

1 - ESQUADRO | CORNER CLEAT | ÉQUERRE 12x9.5 JT  
3 - CANTO | CORNER | ANGLE CR S/SB

2 - ESQUADRO | CORNER CLEAT | ÉQUERRE 11x20.5 JT  
4 - CANTO ALINHAMENTO | ALIGNMENT CORNER | ANGLE D'ALIGNEMENT JT

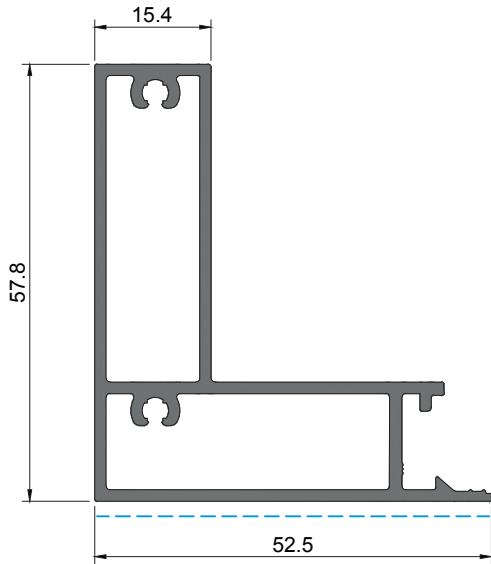

**JT 93**

Perfil montante para solução de embutir

Mullion profile for pocket solution | Profilé de meneau pour galandage

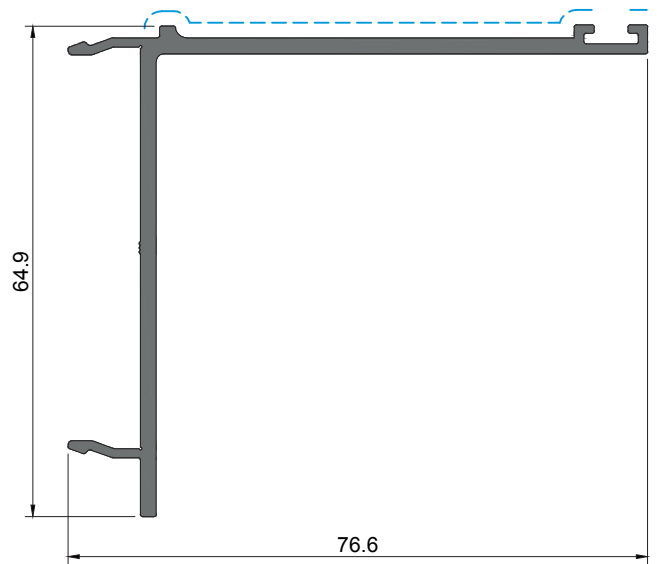

**SO 46**

Perfil remate para solução de embutir

Finishing profile for pocket solution | Profilé de finition pour galandage

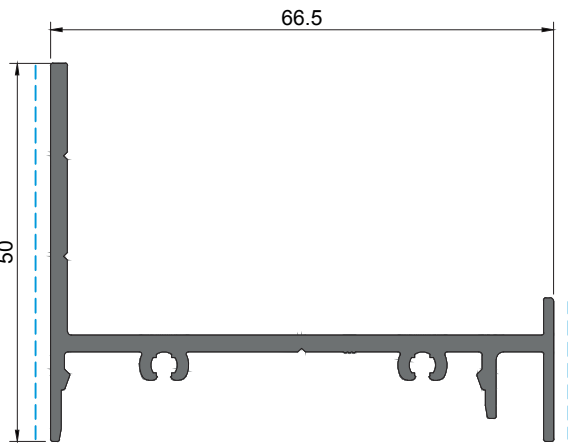

**SO 47**

Perfil remate para solução de embutir

Finishing profile for pocket solution | Profilé de finition pour galandage

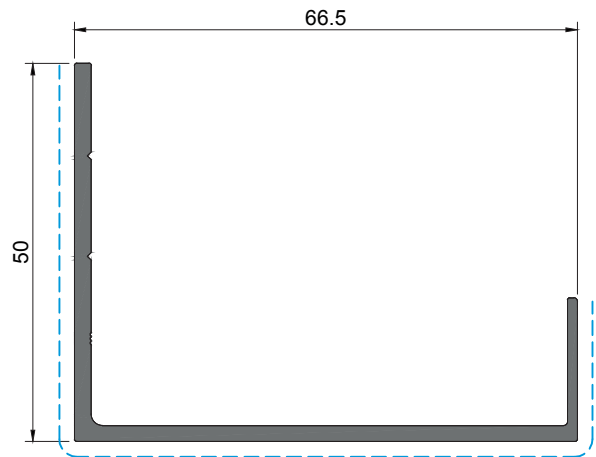

**SO 48**

Perfil remate para solução de embutir

Finishing profile for pocket solution | Profilé de finition pour galandage

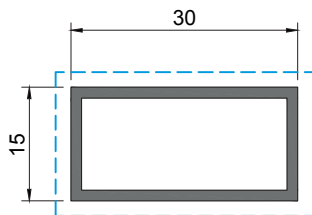

**KP 32**

Tubo  
Tube | Tube

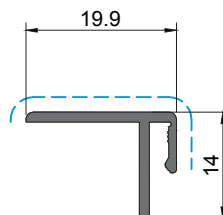

**JT 81**

Perfil complementar

Complementary profile | Profilé complémentaire

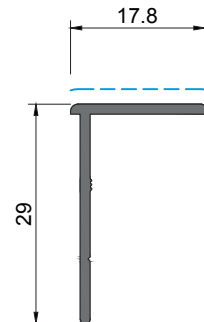

**JM 81**

Perfil complementar

Complementary profile | Profilé complémentaire



TIPOLOGIAS C/ FOLHAS JT | TYPOLOGIES W/ JT SASHES | TYPOLOGIES AVEC VANTAUX JT

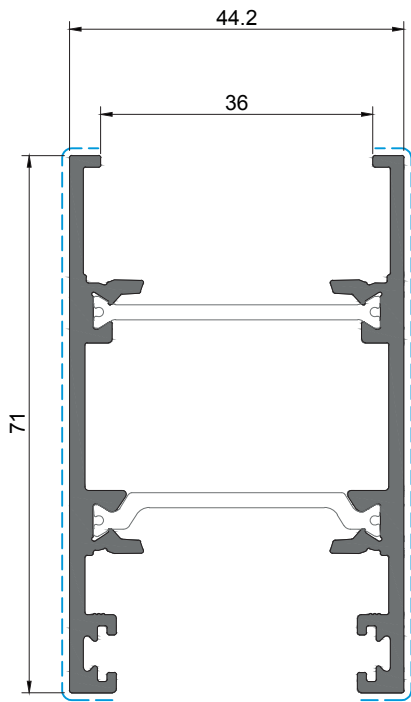

**JT 61**  
Perfil lateral  
Lateral profile | Profilé latéral  
(Janelas)  
(Windows)  
(Fenêtres)

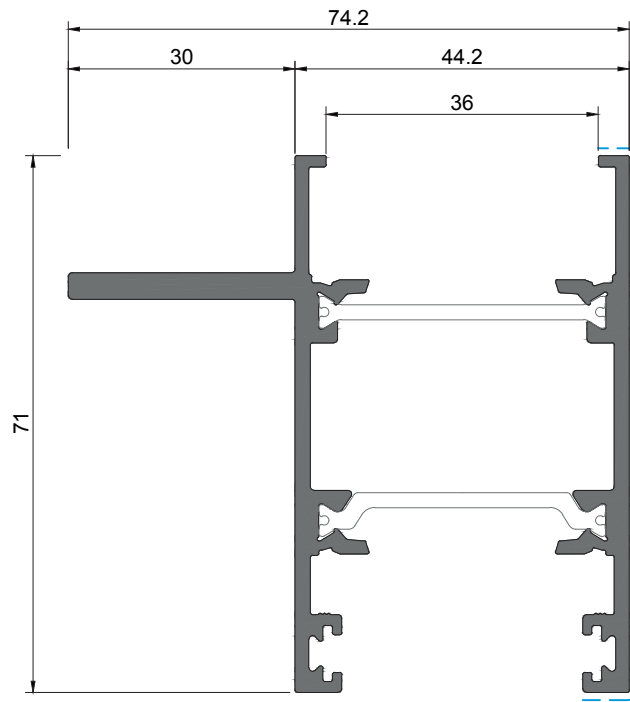

**JT 64**  
Perfil lateral  
Lateral profile | Profilé latéral  
(Janelas/Sacadas)  
(Windows/Full height windows)  
(Fenêtres/Porte-fenêtres)

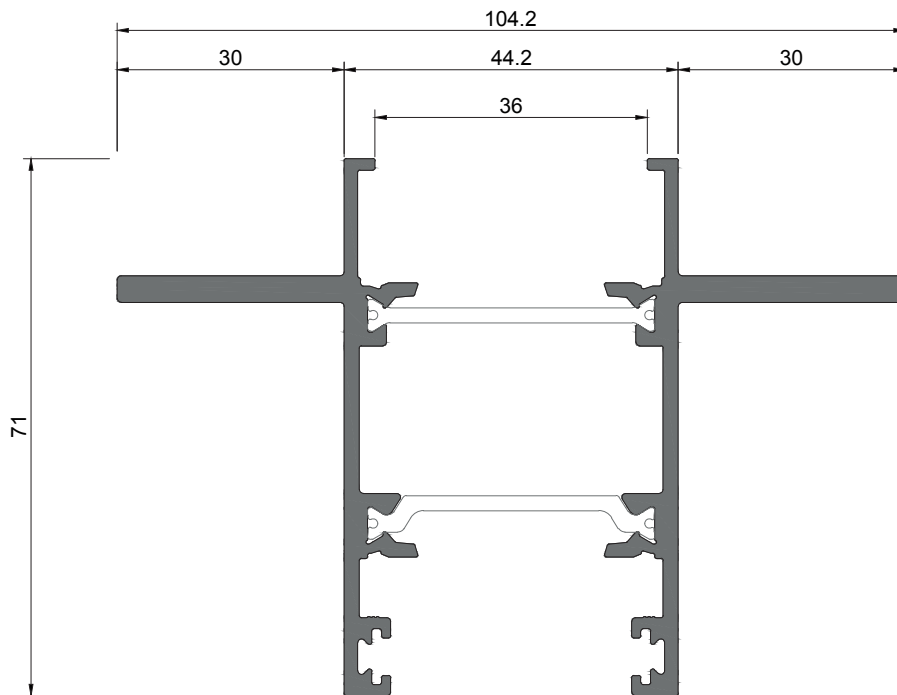

**JT 65**  
Perfil lateral  
Lateral profile | Profilé latéral  
(Janelas/Sacadas)  
(Windows/Full height windows)  
(Fenêtres/Porte-fenêtres)

TIPOLOGIAS C/ FOLHAS JT | TYPOLOGIES W/ JT SASHES | TYPOLOGIES AVEC VANTAUX JT

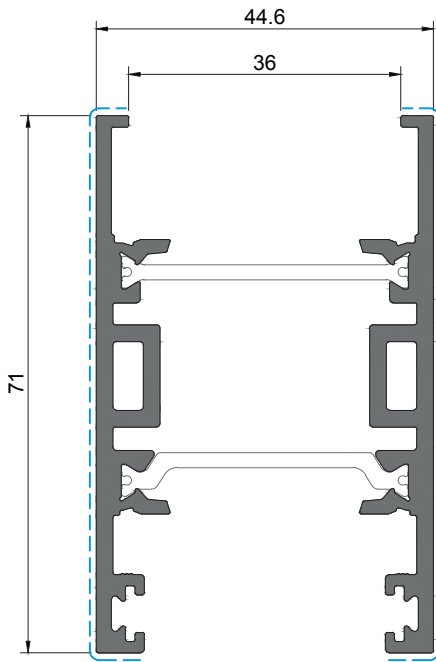

**JT 66**  
Perfil lateral  
Lateral profile | Profilé latéral  
(Janelas/Sacadas)  
(Windows/Full height windows)  
(Fenêtres/Porte-fenêtres)

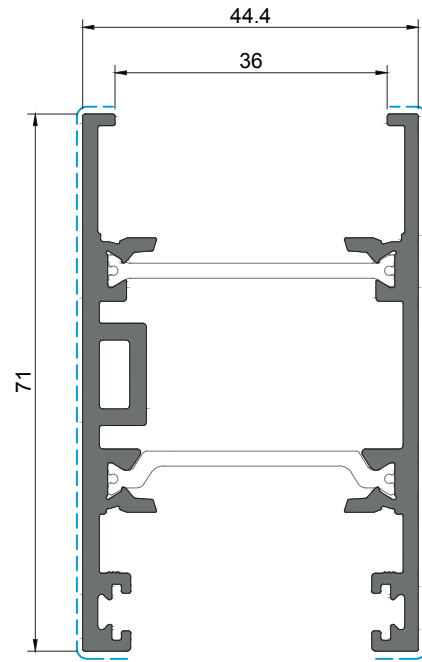

**JT 67**  
Perfil lateral  
Lateral profile | Profilé latéral  
(Janelas/Sacadas)  
(Windows/Full height windows)  
(Fenêtres/Porte-fenêtres)

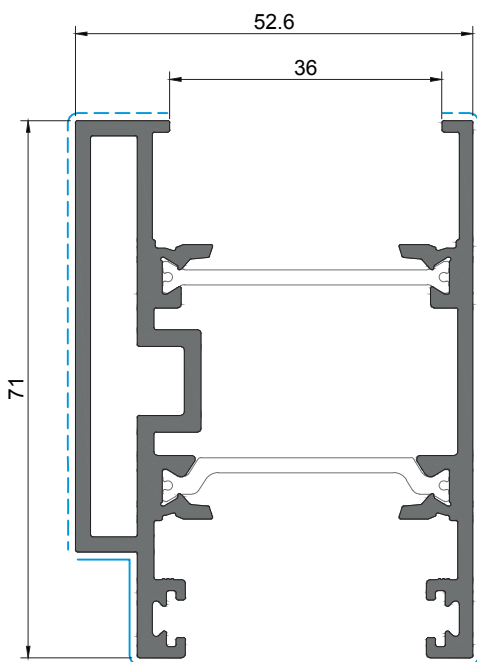

**JT 68**  
Perfil lateral  
Lateral profile | Profilé latéral  
(Sacadas)  
(Full height windows)  
(Porte-fenêtres)

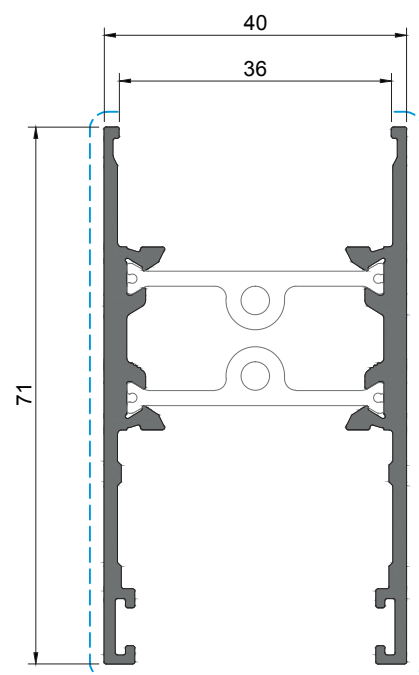

**JT 63**  
Travessa superior/inferior  
Upper/lower transom | Traverse supérieur/inférieur

Treatmento de superficie | Surface treatment | Traitement de surface  
PB | PPM | EF | EM  
PB | PPM | EF | EM  
Para mais informações, consultar Catálogo de Cores Anodizadas  
For further information, consult the Anodised Colours Catalogue | Pour plus d'informations, veuillez consulter le Catalogue des Couleurs Anodisées

TIPOLOGIAS C/ FOLHAS JT | TYPOLOGIES W/ JT SASHES | TYPOLOGIES AVEC VANTAUX JT

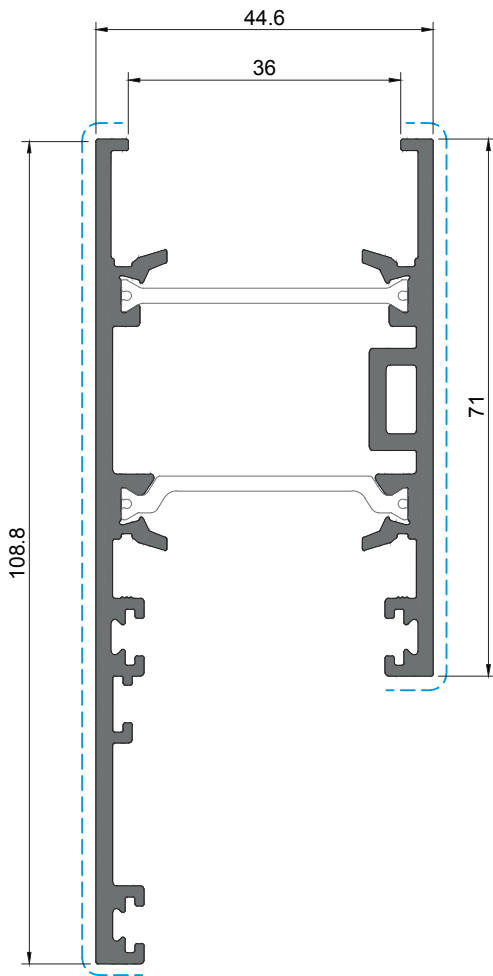

**JT 62**

Perfil lateral canto 90°

90° Corner lateral profile | Profilé latéral d'angle à 90°

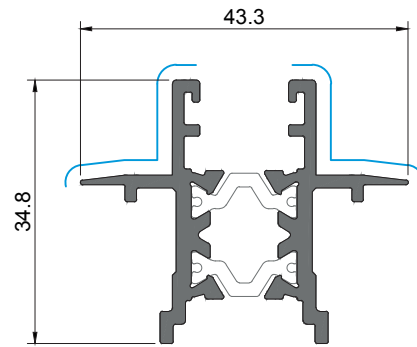

**JT 71**

Perfil ligação central

Central connecting profile | Profilé de liaison centrale

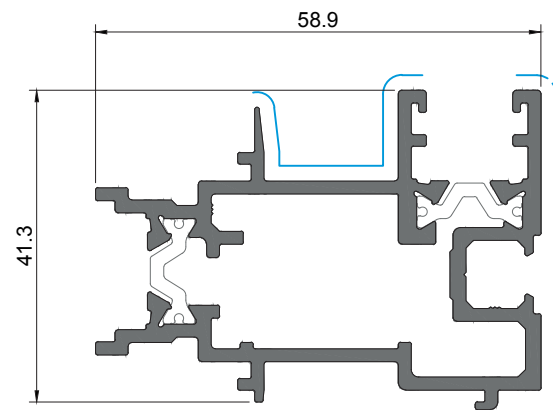

**JT 72**

Perfil ligação canto 90°

90° Corner connection profile | Profilé de liaison d'angle à 90°

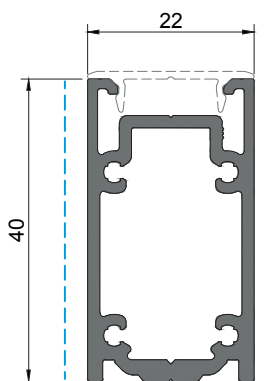

**JE 35**

Perfil de reforço/puxador

Reinforcement profile/handle | Profilé de renforcement/poignée

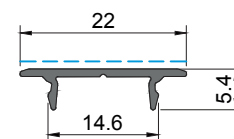

**OS 30**

Tampa

Cover | Capot

TIPOLOGIAS C/ FOLHAS JT | TYPOLOGIES W/ JT SASHES | TYPOLOGIES AVEC VANTAUX JT

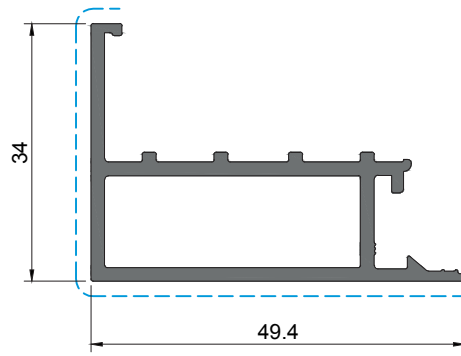

**JT 51**  
Perfil central  
Central profile | Profilé central

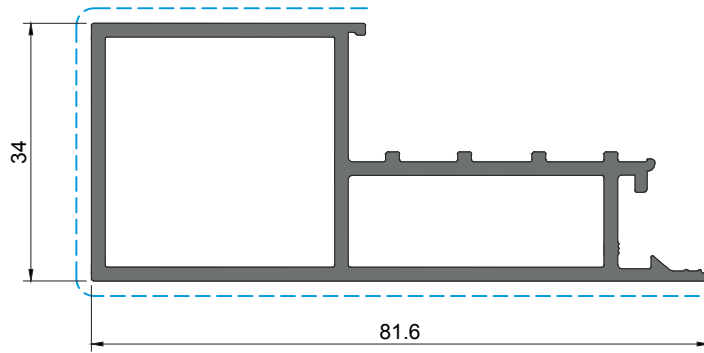

**JT 52**  
Perfil central reforçado  
Reinforced central profile | Profilé central renforcé

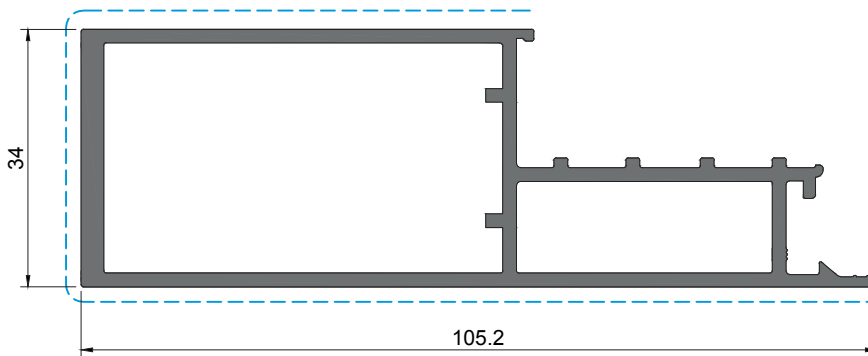

**JT 53**  
Perfil central reforçado  
Reinforced central profile | Profilé central renforcé

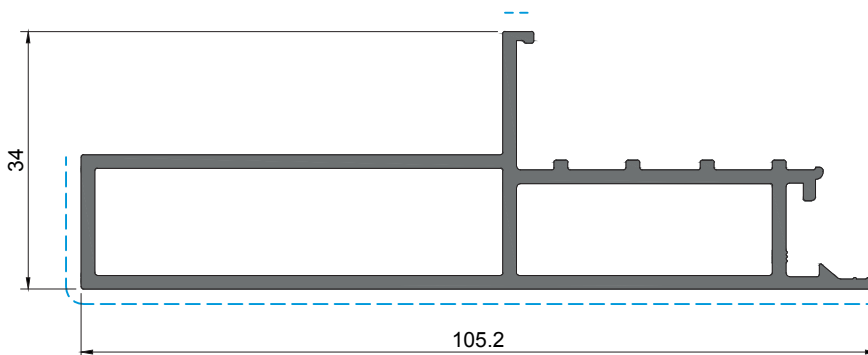

**JT 54**  
Perfil central reforçado  
Reinforced central profile | Profilé central renforcé

Treatmento de superficie | Surface treatment | Traitement de surface  
PB | IPM | IEF | IEM  
Para mais informações, consultar Catálogo de Cores Anodizadas  
For further information, consult the Anodised Colours Catalogue | Pour plus d'informations, veuillez consulter le Catalogue des Couleurs Anodisées

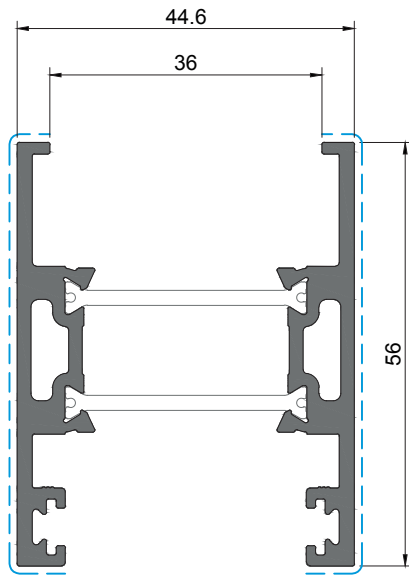

**JT 60**  
Perfil lateral  
Lateral profile | Profilé latéral

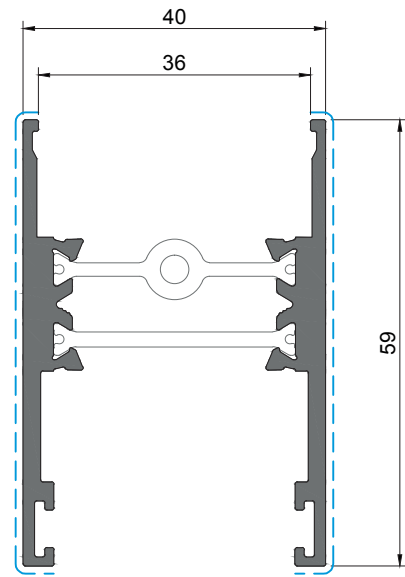

**JT 69**  
Travessa superior/inferior  
Upper/lower transom | Traverse supérieur/inférieur

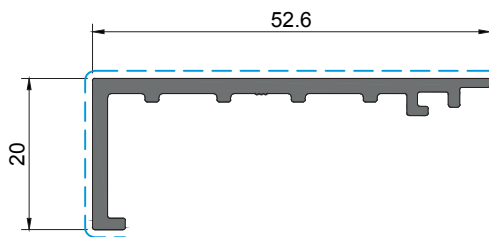

**JT 55**  
Perfil central  
Central profile | Profilé central

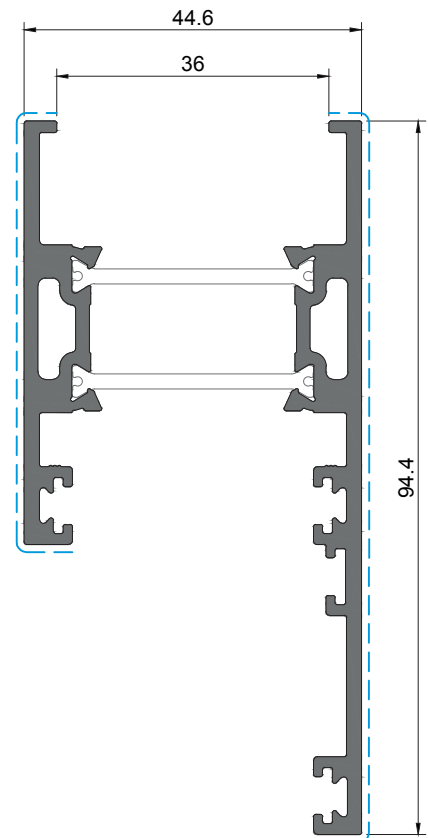

**JT 70**  
Perfil lateral canto 90°  
90° Corner lateral profile | Profilé latéral d'angle à 90°

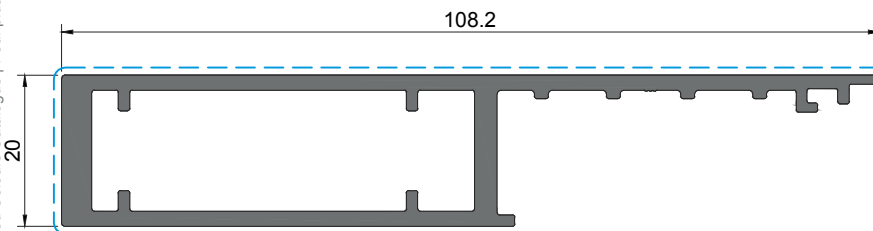

**JT 56**  
Perfil central reforçado  
Reinforced central profile | Profilé central renforcé

TIPOLOGIAS C/ FOLHAS FIXAS | TYPOLOGIES W/ FIXED SASHES | TYPOLOGIES AVEC VANTAUX FIXES

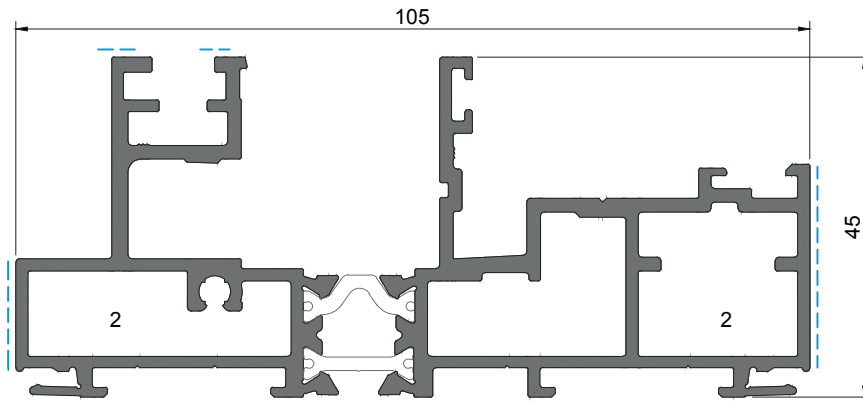

**JT 15**

Aro para tipologias fixas 2rail (vão fixo interior)

2rail fixed typologies frame (inside fixed frame) | Cadre dormant pour typologies fixes 2rail (vantaux fixe intérieure)

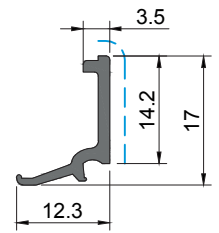

**JE 95**

Bite

Bead | Parclose

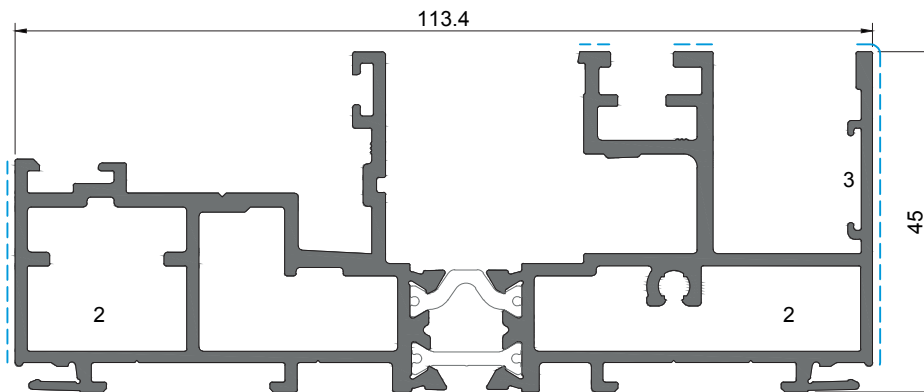

**JT 16**

Aro para tipologias fixas 2rail (vão fixo exterior)

2rail fixed typologies frame (outside fixed frame) | Cadre dormant pour typologies fixes 2rail (vantaux fixe extérieure)

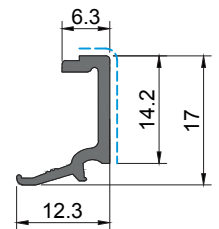

**JE 97**

Bite

Bead | Parclose

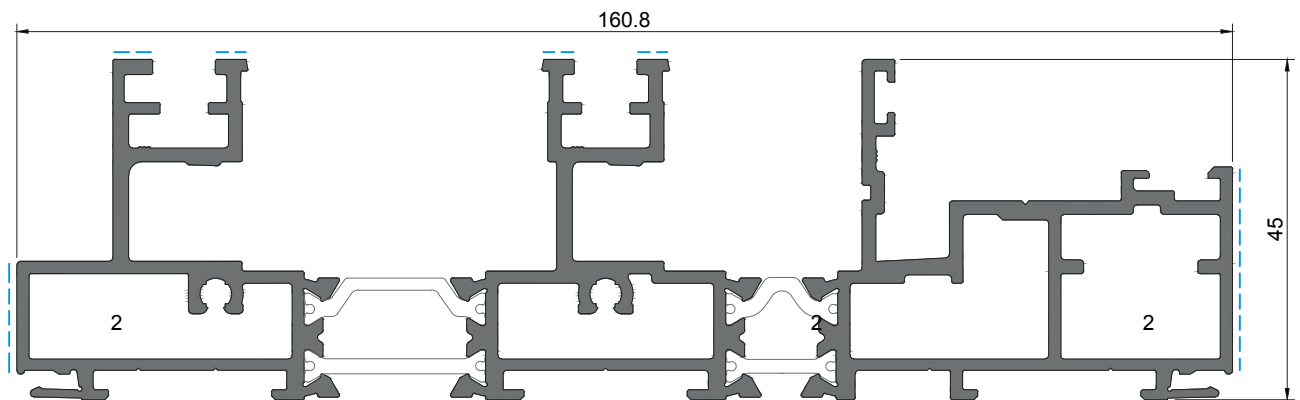

**JT 25**

Aro para tipologias fixas 3rail

3rail fixed typologies frame | Cadre dormant pour typologies fixes 3rail

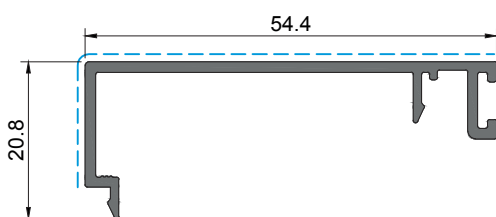

**JT 89**

Capa

Cover | Capot

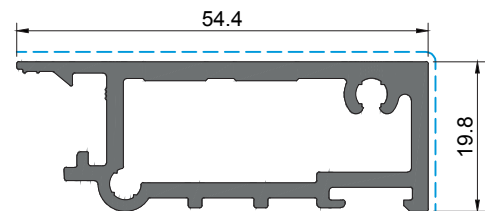

**JT 94**

Perfil montante para tipologias fixas

Mullion profile for fixed typologies | Profilé de meneau pour typologies fixes

1 - ESQUADRO | CORNER CLEAT | ÉQUERRE 12x9.5 JT  
3 - CANTO | CORNER | ANGLE CR S/SB

2 - ESQUADRO | CORNER CLEAT | ÉQUERRE 11x20.5 JT  
4 - CANTO ALINHAMENTO | ALIGNMENT CORNER | ANGLE D'ALIGNEMENT JT



Treatamento de superfície | Surface treatment | Traitement de surface  
 PB | PPM | EF | EM PB | PPM | EF | EM  
 Para mais informações, consultar **Catálogo de Cores Anodizadas**  
 For further information, consult the **Anodised Colours Catalogue** | Pour plus d'informations, veuillez consulter le **Catologue des Couleurs Anodisées**

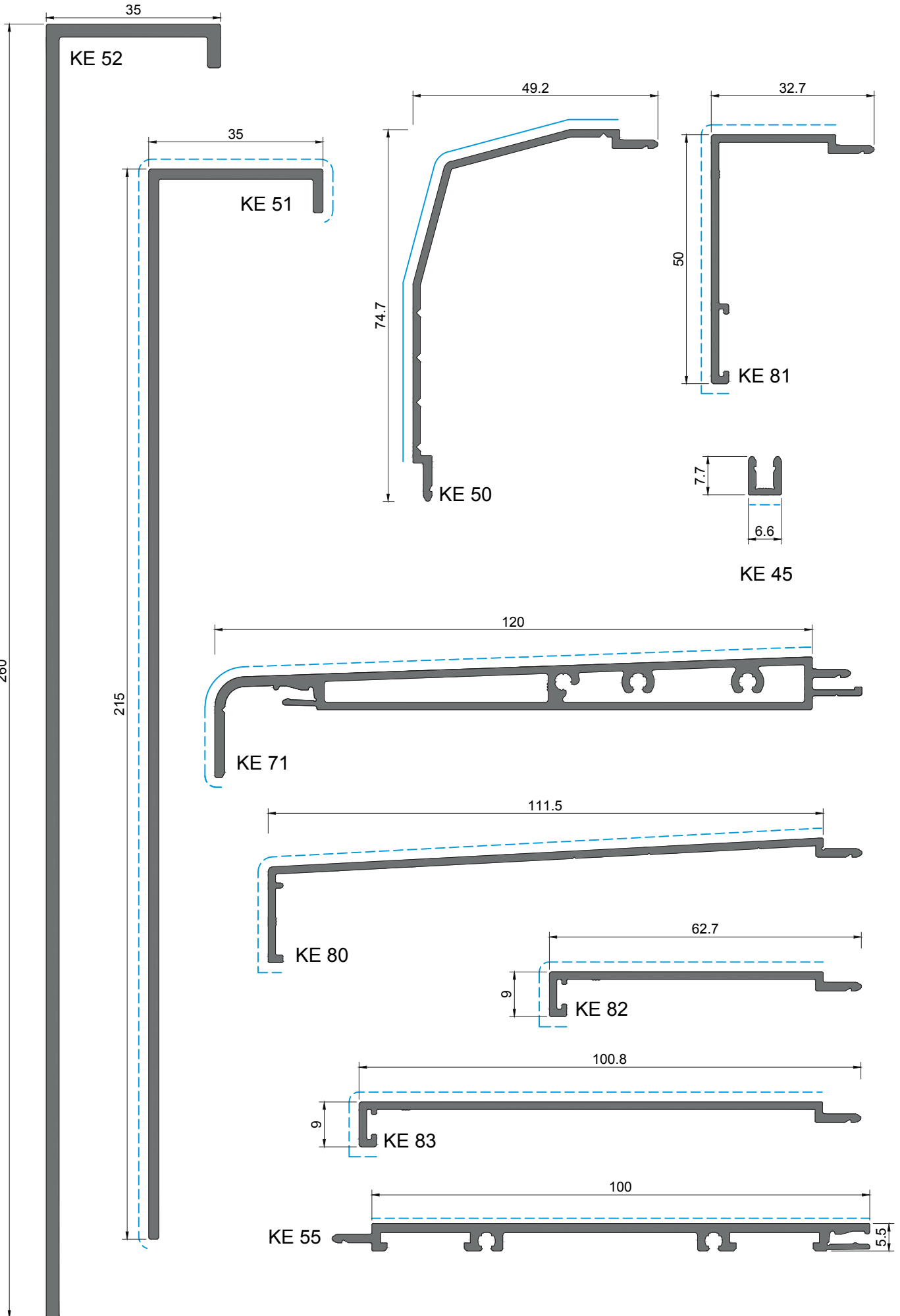

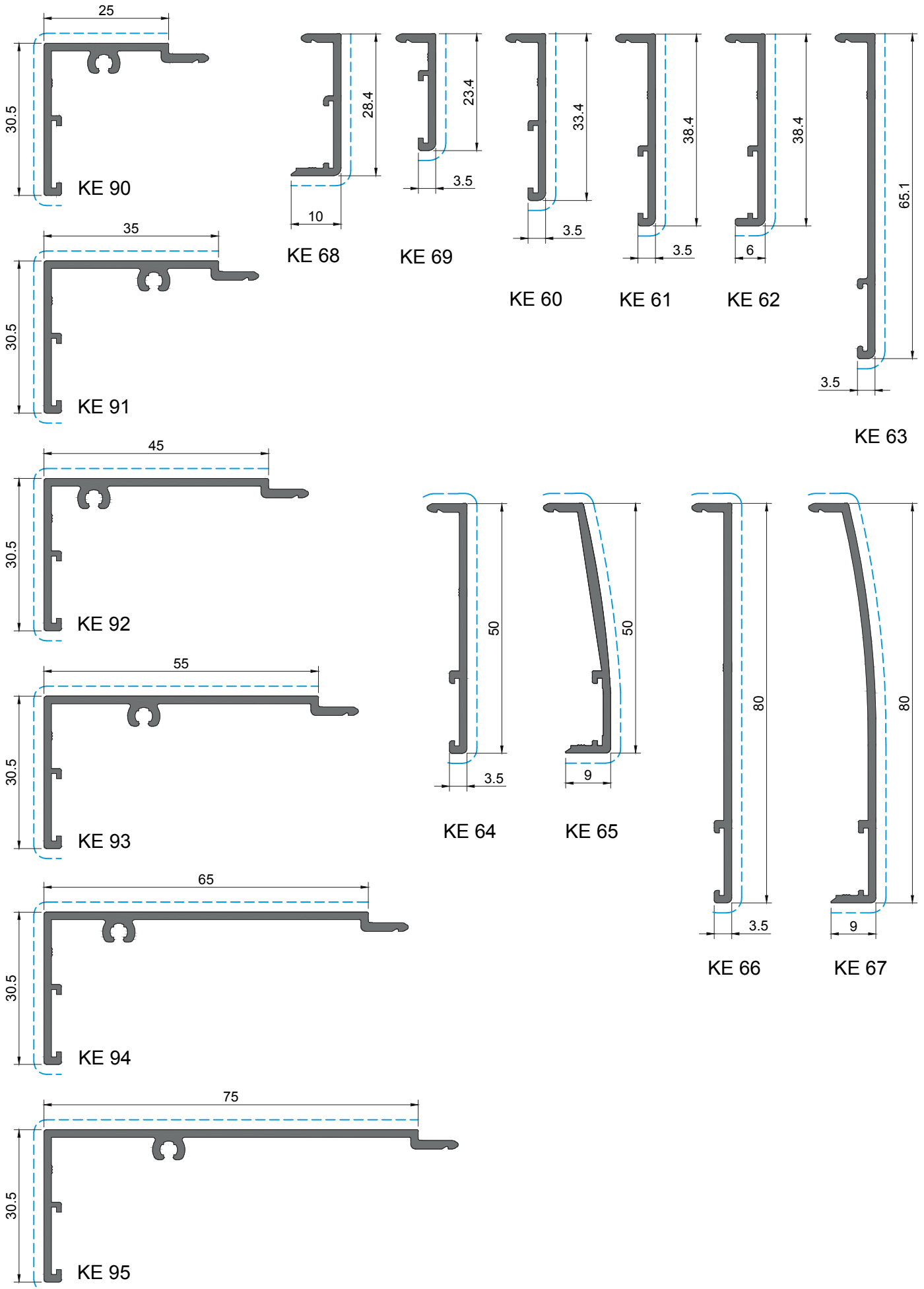

Treatmento de superficie | Surface treatment | Traitement de surface  
 PB | PPM | EF | EM  
 Para mais informações, consultar **Catálogo de Cores Anodizadas**  
 For further information, consult the **Anodised Colours Catalogue** | Pour plus d'informations, veuillez consulter le **Catálogo des Couleurs Anodisées**

TABELA ORIENTATIVA DE BITES | GLAZING BEADS SCHEDULE | TABLE DES PARCLOSES

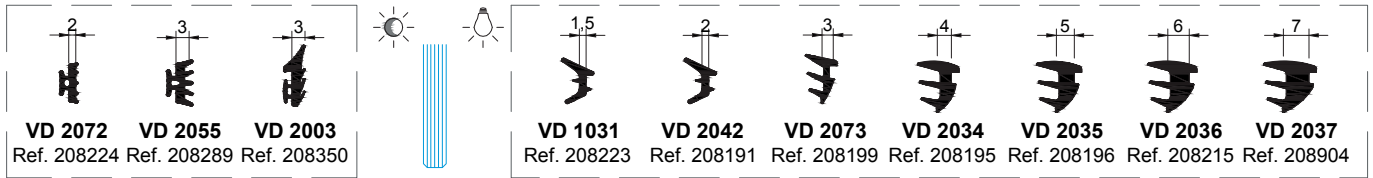

VEDANTE EXTERIOR OUTER GASKET JOINT EXTÉRIEUR	ESPESSURA DO VIDRO GLASS THICKNESS ÉPAISSEUR DU VERRE	VEDANTE INTERIOR INNER GASKET JOINT INTÉRIEUR	BITES GLAZING BEADS PARCLOSES
2003	31	2037	JE 95
2003	32	2036	JE 95
2003	33	2035	JE 95
2003	34	2034	JE 95
2003	28	2037	JE 97
2003	29	2036	JE 97
2003	30	2035	JE 97
2003	31	2034	JE 97
2003	32	2073	JE 97
2072	33	2073	JE 97
2072	34	2042	JE 97

**Aconselha-se sempre a utilização do vedante VD 2003 pelo exterior.**  
It is always advisable to use VD 2003 gasket in the outer side.  
Il est toujours conseillé d'utiliser le joint VD 2003 de l'extérieur.

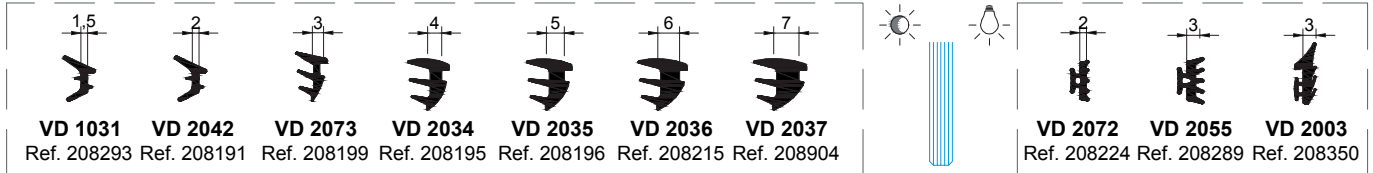
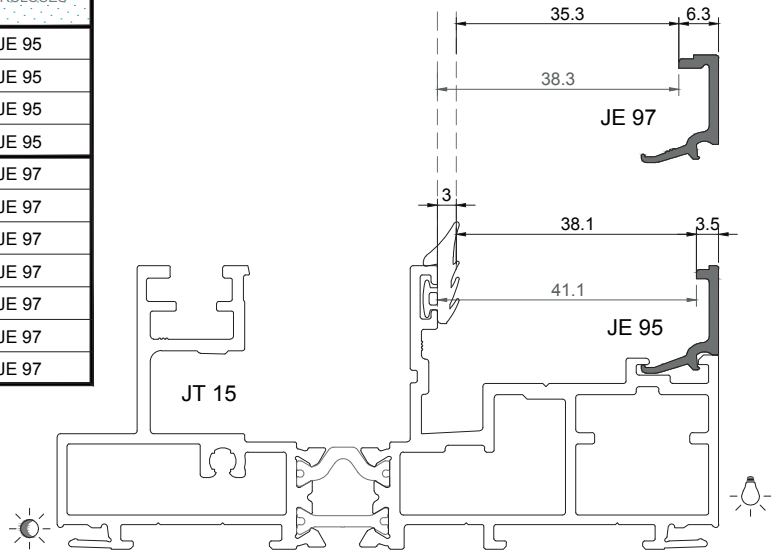

VEDANTE EXTERIOR OUTER GASKET JOINT EXTÉRIEUR	ESPESSURA DO VIDRO GLASS THICKNESS ÉPAISSEUR DU VERRE	VEDANTE INTERIOR INNER GASKET JOINT INTÉRIEUR	BITES GLAZING BEADS PARCLOSES
2037	31	2003	JE 95
2036	32	2003	JE 95
2035	33	2003	JE 95
2034	34	2003	JE 95
2037	28	2003	JE 97
2036	29	2003	JE 97
2035	30	2003	JE 97
2034	31	2003	JE 97
2073	32	2003	JE 97
2073	33	2072	JE 97
2042	34	2072	JE 97

**Aconselha-se sempre a utilização do vedante VD 2003 pelo interior.**  
It is always advisable to use VD 2003 gasket in the inside.  
Il est toujours conseillé d'utiliser le joint VD 2003 de l'intérieur.

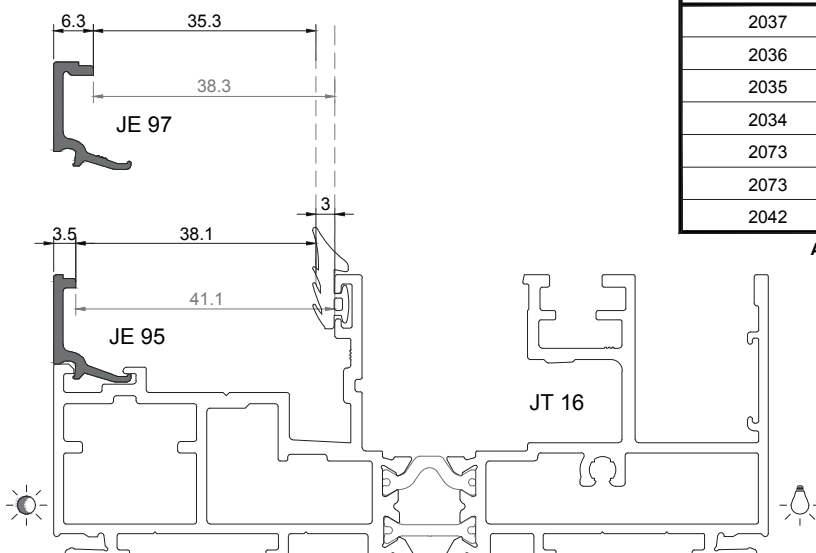



Edifício Varandas do Rio | Águeda | Arq.ª Sofia Soares



**LISTAGEM DE ACESSÓRIOS**  
**ACCESSORIES LIST | LIST D'ACCESSOIRES**

**Juntas de vidro, vedantes e pelúcias**

Glazing gaskets, seals and pile seals | Joints de vitrage, joints et joints brosse

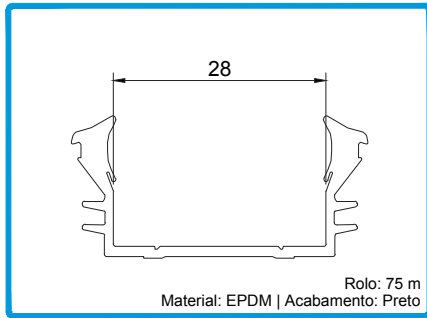

**208477** JUNTA VIDRO U 1028 CX 28MM JT

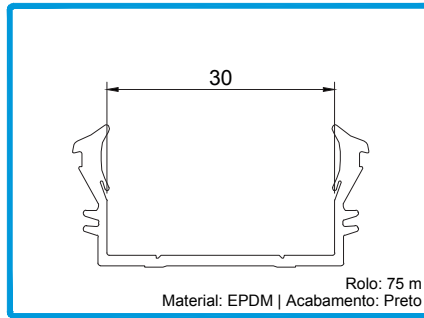

**208478** JUNTA VIDRO U 1030 CX 30MM JT

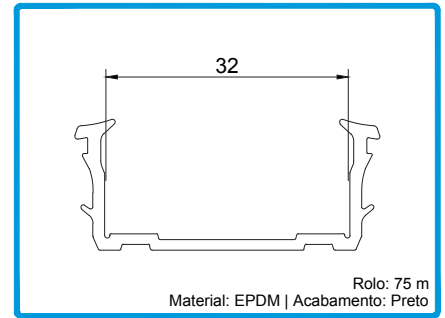

**208099** JUNTA VIDRO U 1032 CX 32MM JT

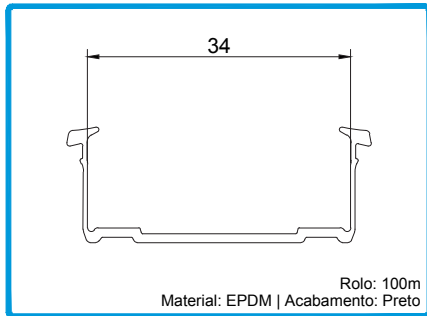

**208483** JUNTA VIDRO U 1034 CX 34MM JT

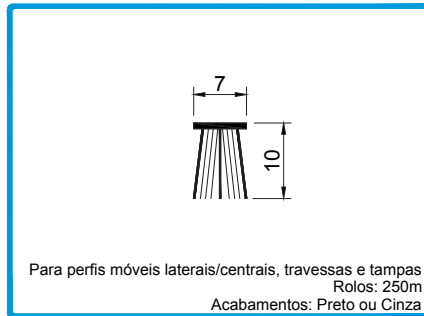

**208306** PELÚCIA 7x10 TRI-FIN Cinza  
**208307** PELÚCIA 7x10 TRI-FIN Preto

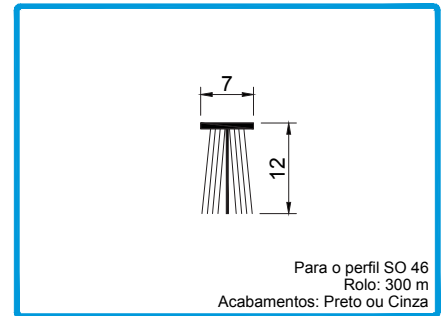

**208593** PELÚCIA 7x12 STOP-FIN Cinza  
**208466** PELÚCIA 7x12 STOP-FIN Preto

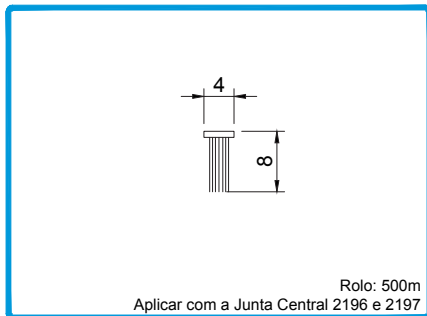

**208469** PELÚCIA SRF 4X8 2P1M Preta

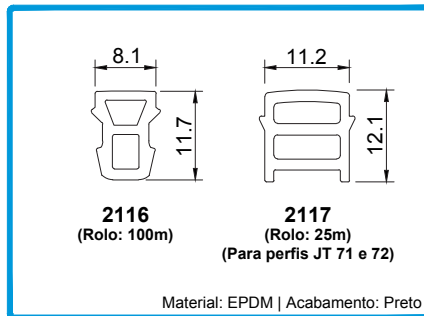

**208348** JUNTA TAPA CANAL 2116 JT  
**208479** JUNTA TAPA CANAL 2117 JT

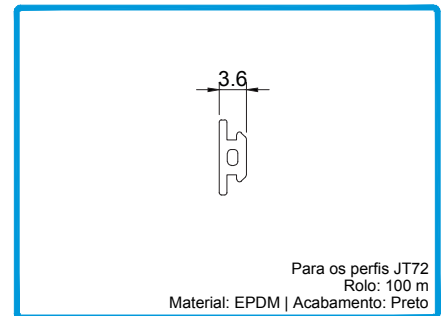

**208435** JUNTA VD 2415 PRT

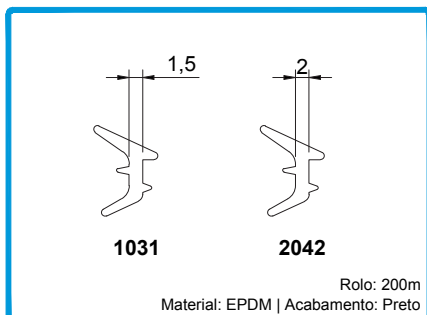

**208223** JUNTA DE CUNHA 1031  
**208191** JUNTA DE CUNHA 2042

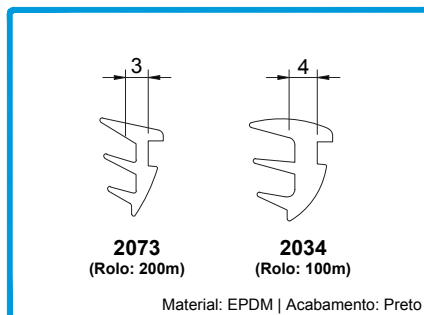

**208199** JUNTA DE CUNHA 2073  
**208195** JUNTA DE CUNHA 2034

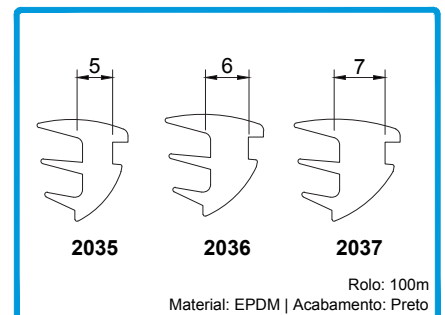

**208196** JUNTA DE CUNHA 2035  
**208215** JUNTA DE CUNHA 2036  
**208904** JUNTA DE CUNHA 2037

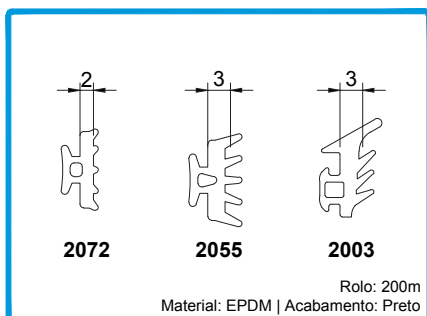

**208224** JUNTA VD 2072  
**208289** JUNTA DE BATENTE 2055  
**208350** JUNTA DE VEDAÇÃO EXT. 2003

**Acessórios para o aro fixo**

Fixed frame accessories | Accessoires pour cadre dormant

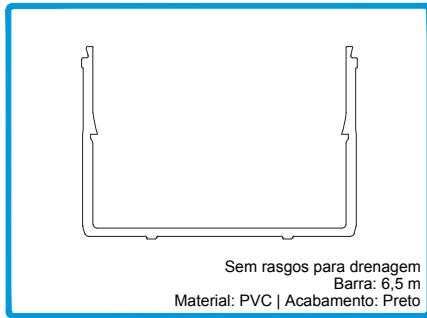

Sem rasgos para drenagem  
Barra: 6,5 m  
Material: PVC | Acabamento: Preto

**215305** PERFIL PVC U JT

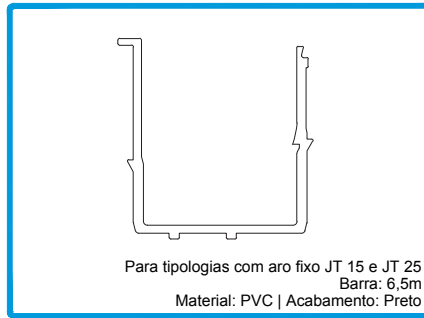

Para tipologias com aro fixo JT 15 e JT 25  
Barra: 6,5m  
Material: PVC | Acabamento: Preto

**215310** PERFIL PVC U JT FIXO

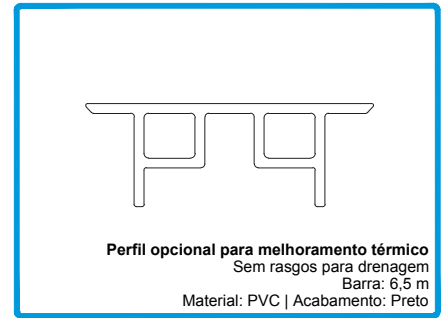

Perfil opcional para melhoria térmica  
Sem rasgos para drenagem  
Barra: 6,5 m  
Material: PVC | Acabamento: Preto

**215303** PERFIL PVC T JT

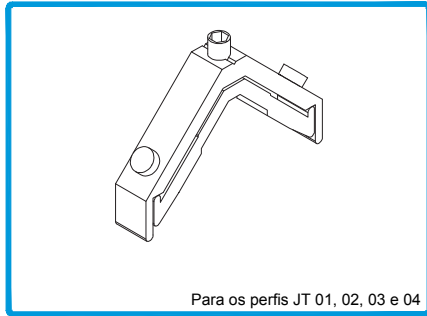

Para os perfis JT 01, 02, 03 e 04

**204164** ESQUADRO JT 12x9.5

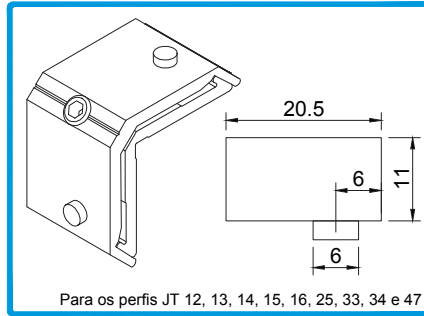

Para os perfis JT 12, 13, 14, 15, 16, 25, 33, 34 e 47

**204153** ESQUADRO JT 11x20.5

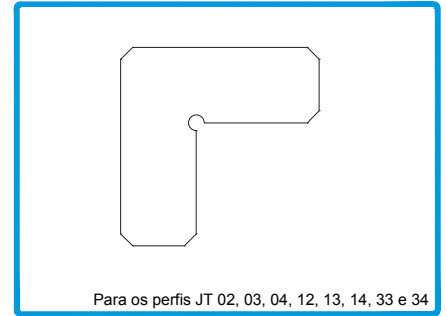

Para os perfis JT 02, 03, 04, 12, 13, 14, 33 e 34

**213246** CANTO CR S/SB

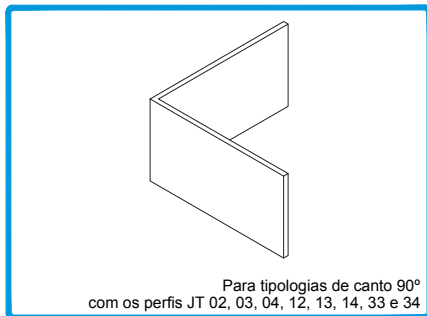

Para tipologias de canto 90°  
com os perfis JT 02, 03, 04, 12, 13, 14, 33 e 34

**204389** ESQUADRO INOX CANTO 90°

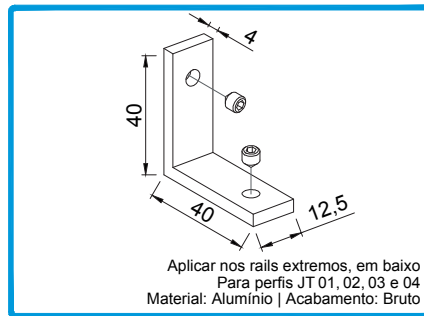

Aplicar nos rails extremos, em baixo  
Para perfis JT 01, 02, 03 e 04  
Material: Alumínio | Acabamento: Bruto

**213014** CANTO ALINHAMENTO JT

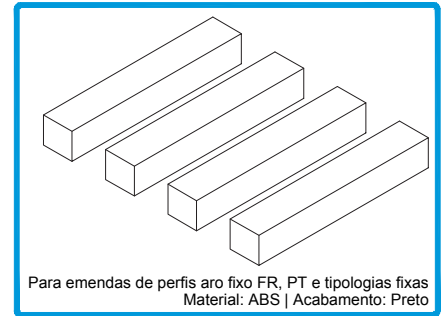

Para emendas de perfis aro fixo FR, PT e tipologias fixas  
Material: ABS | Acabamento: Preto

**212242** CONJ. UNIÃO RETA JT

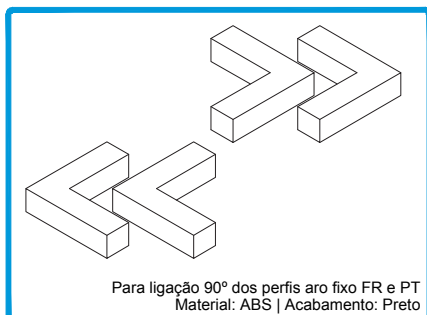

Para ligação 90° dos perfis aro fixo FR e PT  
Material: ABS | Acabamento: Preto

**212243** CONJ. UNIÃO CANTO 90° JT

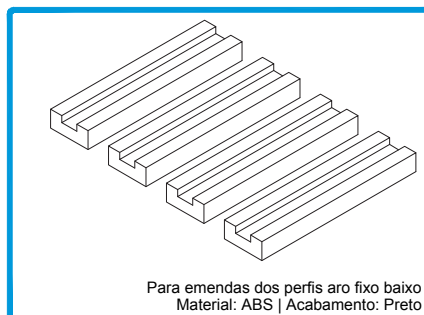

Para emendas dos perfis aro fixo baixo  
Material: ABS | Acabamento: Preto

**212083** CONJ. UNIÃO RETA ARO BAIXO JT

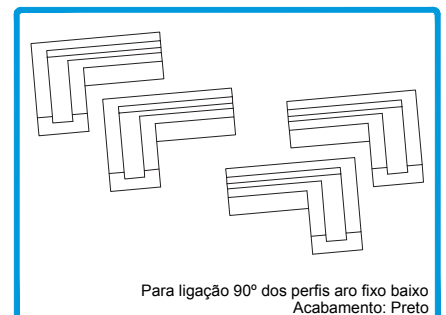

Para ligação 90° dos perfis aro fixo baixo  
Acabamento: Preto

**212084** CONJ. UNIÃO CANTO 90° ARO BAIXO JT

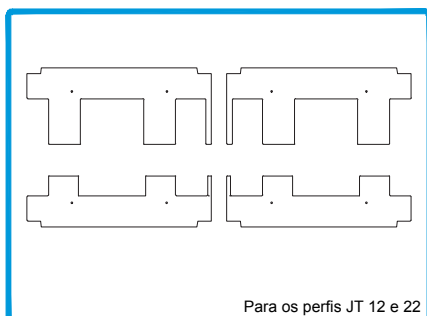

Para os perfis JT 12 e 22

**223105** KIT JUNTAS ADESIVAS N°1 JT

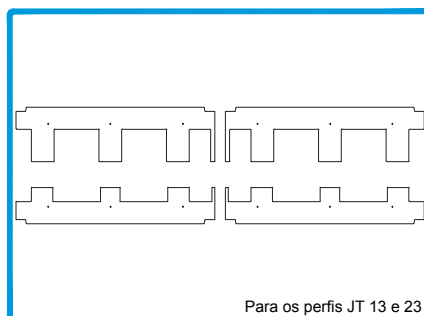

Para os perfis JT 13 e 23

**223106** KIT JUNTAS ADESIVAS N°2 JT

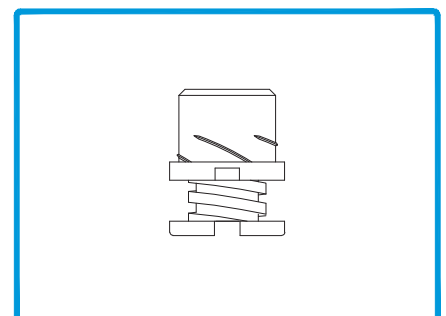

**224205** NIVELADOR PEQUENO 600.01/8

**Acessórios de estanqueidade**

Watertightness accessories | Accessoires d'étanchéité

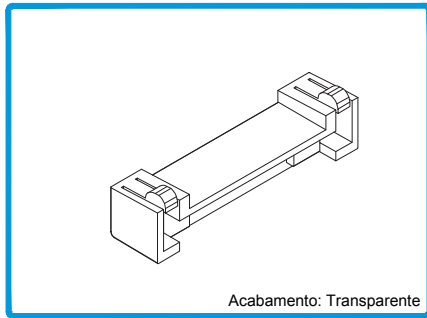

Acabamento: Transparente

**210269** GOTEIRA OCULTA C/ VÁLV. SV-C13



Acabamentos: Preto e Transparente

**210265** GOTEIRA C/ VÁLV. BOLA

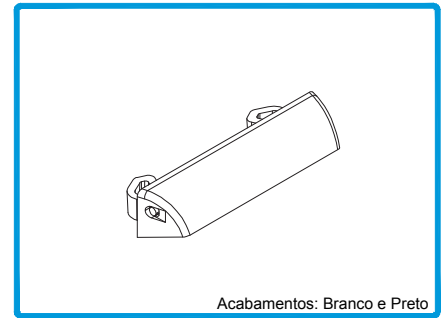

Acabamentos: Branco e Preto

**210268** GOTEIRA C/ VÁLV. SVE

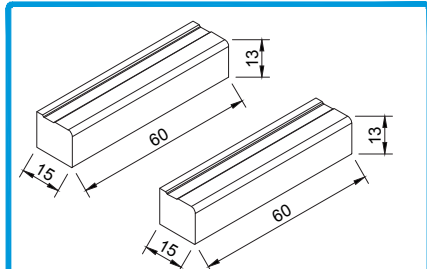

Para os perfis aro fixo FR, PT e tipologias fixas, em baixo  
Material: EPDM | Acabamento: Preto

**212337** CONJ. ESTANQUEIDADE CORTA-VENTO JT

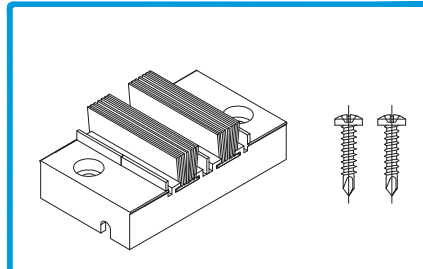

Para os perfis aro fixo FR, PT e tipologias fixas

**213286** CORTA-VENTO JT

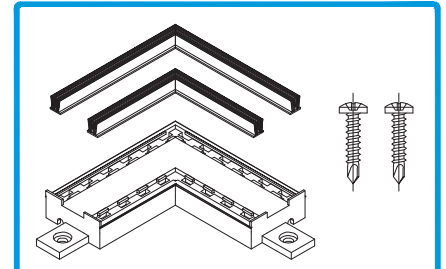

Para os perfis aro fixo FR e PT em canto 90°

**213287** CORTA-VENTO CANTO 90° JT

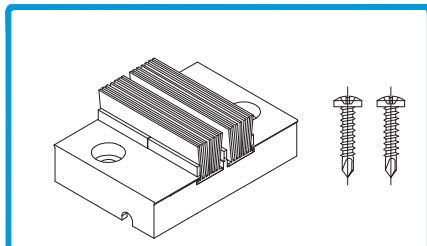

Para os perfis aro fixo FR e PT com as linhas JT e JT-Slim em tipologias com centrais JT 55 e JT 56  
Material: ABS | Acabamento: Preto

**213402** CORTA VENTO JT-SLIM

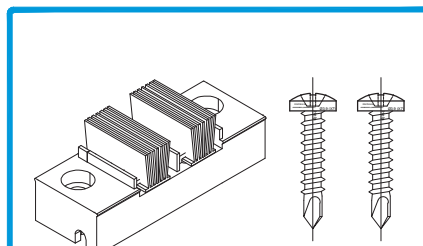

Para os perfis JT 15 e JT 25  
Material: EPDM | Acabamento: Preto

**213303** CORTA VENTO JT FIXO

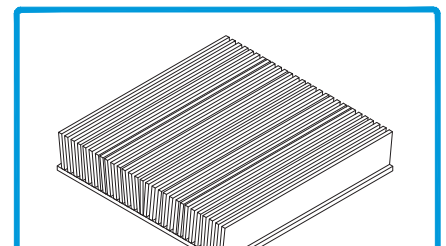

Para os perfis JT 22, 23 e 43  
Necessário cortar nas tipologias com folhas JT-Slim

**213288** CORTA-VENTO BAIXO JT

**Acessórios para tipologias de embutir**

Pocket typologies accessories

Accessoires pour typologies à galandage

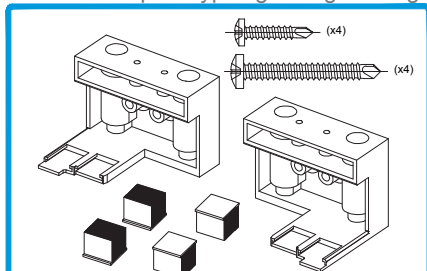

Para o perfil JT 93  
Material: Poliamida | Acabamento: Preto

**212085** CONJ. TOPOS JT93

**Acessórios para tipologias fixas**

Fixed typologies accessories

Accessoires pour typologies fixes

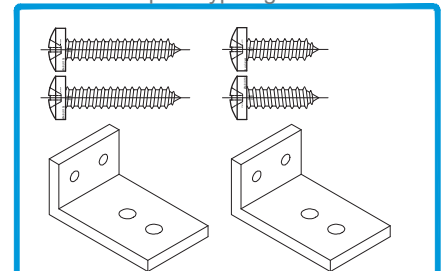

Para fixação do perfil JT 94

**212087** CONJ. FIXAÇÃO JT 94



**Carrinhos**  
Rollers | Rouleaux

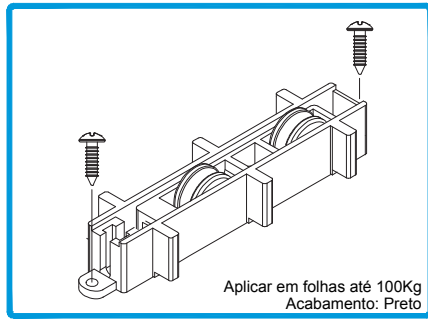

Aplicar em folhas até 100Kg  
Acabamento: Preto

**205108** CARRINHO JT 100KG

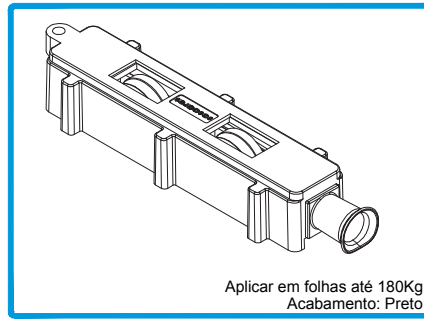

Aplicar em folhas até 180Kg  
Acabamento: Preto

**205129** CARRINHO JT 180KG

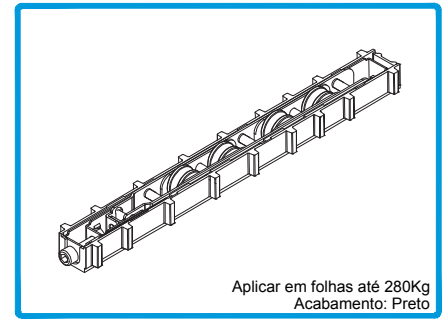

Aplicar em folhas até 280Kg  
Acabamento: Preto

**205201** CARRINHO JT HEAVY DUTY

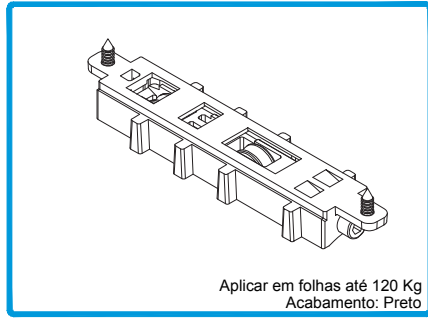

Aplicar em folhas até 120 Kg  
Acabamento: Preto

**205000** CARRINHO JT-SLIM

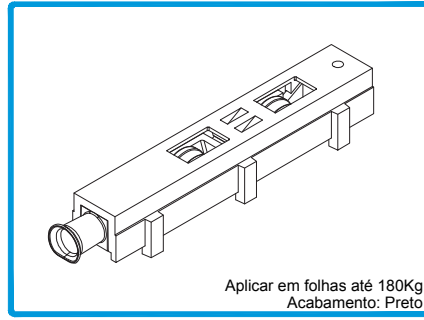

Aplicar em folhas até 180Kg  
Acabamento: Preto

**205111** CARRINHO JT-SLIM 180KG

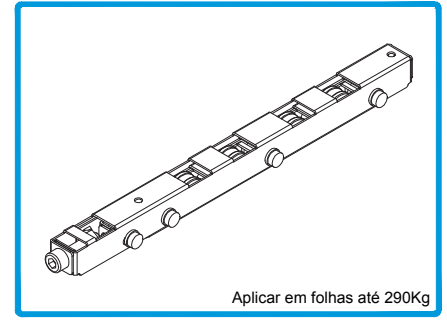

Aplicar em folhas até 290Kg

**205202** CARRINHO JT-SLIM HEAVY DUTY

**Acessórios para perfis laterais**

Lateral profiles accessories | Accessoires pour profilés latéraux

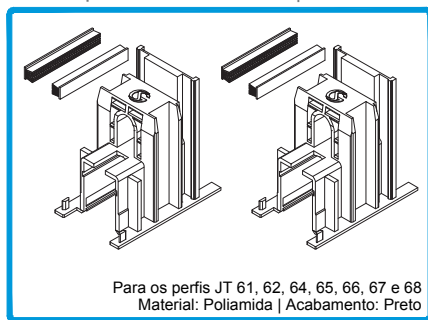

Para os perfis JT 61, 62, 64, 65, 66, 67 e 68  
Material: Poliamida | Acabamento: Preto

**212199** CONJ. TOPOS LAT. JT N°1

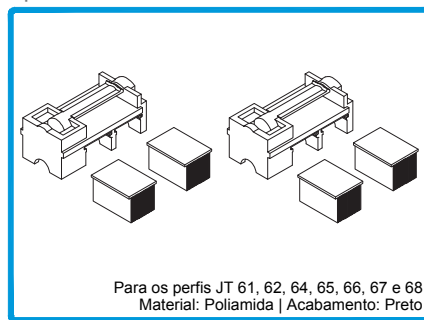

Para os perfis JT 61, 62, 64, 65, 66, 67 e 68  
Material: Poliamida | Acabamento: Preto

**212230** CONJ. TOPOS INTERIORES LAT. JT

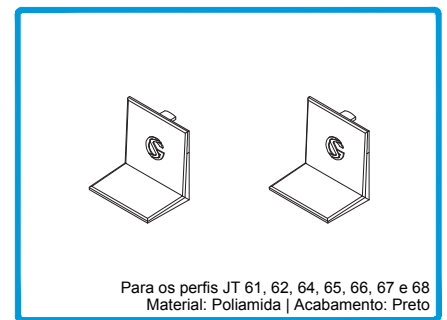

Para os perfis JT 61, 62, 64, 65, 66, 67 e 68  
Material: Poliamida | Acabamento: Preto

**212201** CONJ. TAMPAS TOPOS LAT. JT

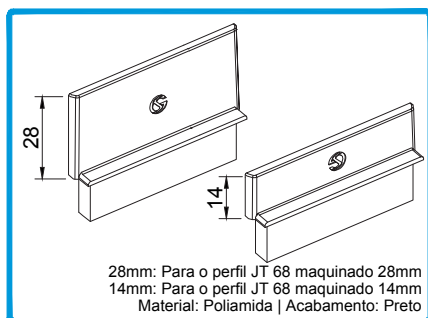

28mm: Para o perfil JT 68 maquinado 28mm  
14mm: Para o perfil JT 68 maquinado 14mm  
Material: Poliamida | Acabamento: Preto

**210288** TOPO LATERAL JT68 28MM  
**210289** TOPO LATERAL JT68 14MM

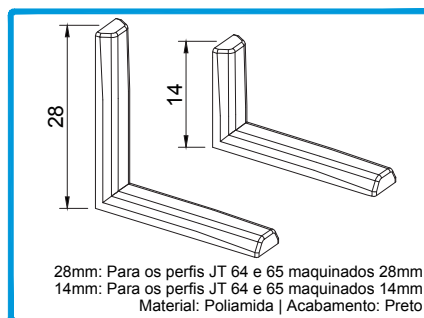

28mm: Para os perfis JT 64 e 65 maquinados 28mm  
14mm: Para os perfis JT 64 e 65 maquinados 14mm  
Material: Poliamida | Acabamento: Preto

**210239** TOPO JT64/JT65 28MM  
**210240** TOPO JT64/JT65 14MM

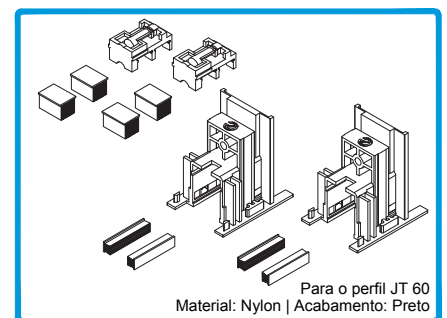

Para o perfil JT 60  
Material: Nylon | Acabamento: Preto

**212131** CONJ. TOPOS LATERAL JT-SLIM



**Acessórios para perfis centrais**

Central profiles accessories | Accessoires pour profilés centraux

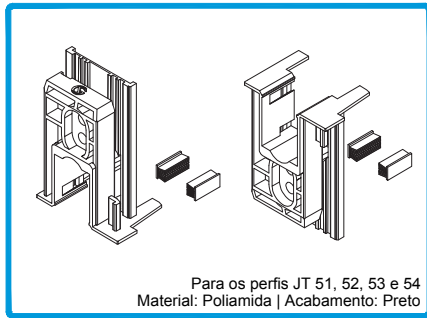

Para os perfis JT 51, 52, 53 e 54  
Material: Poliamida | Acabamento: Preto

**212231** CONJ. TOPOS CENTRAIS JT Nº1

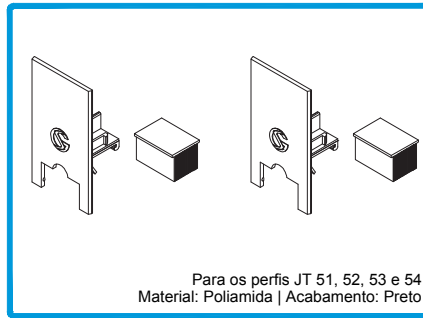

Para os perfis JT 51, 52, 53 e 54  
Material: Poliamida | Acabamento: Preto

**212339** CONJ. TAMPAS TOPOS CENTRAIS JT Nº1

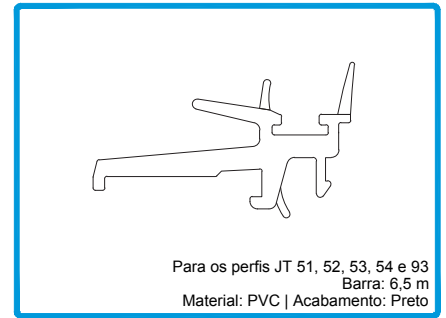

Para os perfis JT 51, 52, 53, 54 e 93  
Barra: 6,5 m  
Material: PVC | Acabamento: Preto

**208346** JUNTA CENTRAL 2196 JT

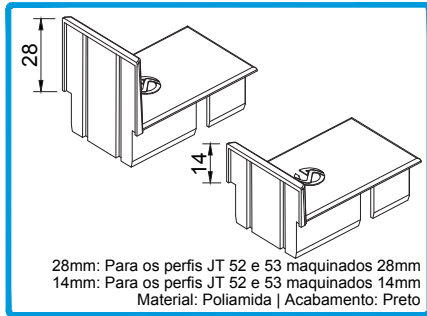

28mm: Para os perfis JT 52 e 53 maquinados 28mm  
14mm: Para os perfis JT 52 e 53 maquinados 14mm  
Material: Poliamida | Acabamento: Preto

**210241** TOPO CENTRAL REFORÇADO 28MM  
**210242** TOPO CENTRAL REFORÇADO 14MM

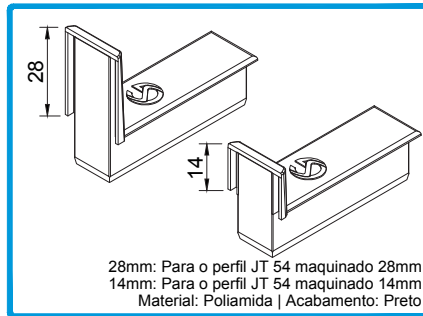

28mm: Para o perfil JT 54 maquinado 28mm  
14mm: Para o perfil JT 54 maquinado 14mm  
Material: Poliamida | Acabamento: Preto

**210243** TOPO CENTRAL REFORÇ. JT54 28MM  
**210244** TOPO CENTRAL REFORÇ. JT54 14MM

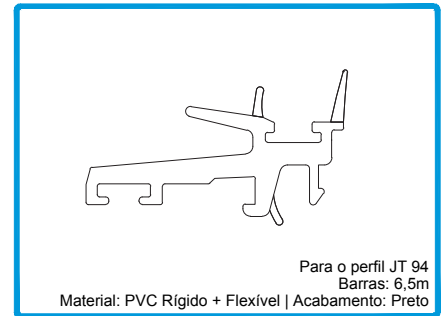

Para o perfil JT 94  
Barra: 6,5m  
Material: PVC Rígido + Flexível | Acabamento: Preto

**208349** JUNTA CENTRAL 2195 JT FIXO

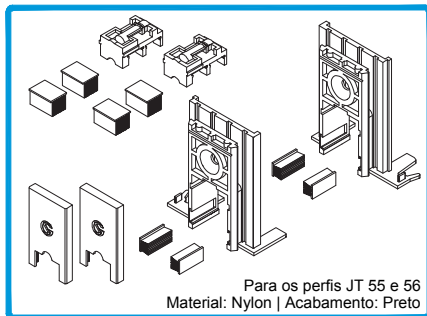

Para os perfis JT 55 e 56  
Material: Nylon | Acabamento: Preto

**212133** CONJ. TOPOS CENTRAL JT-SLIM

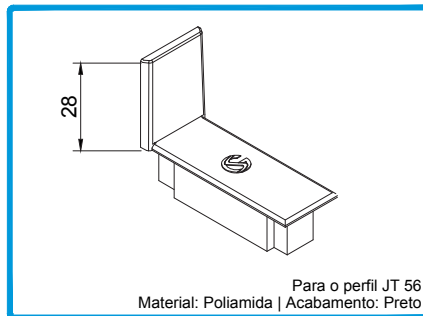

Para o perfil JT 56  
Material: Poliamida | Acabamento: Preto

**210231** TOPO CENTRAL REFORÇADO JT56 28MM

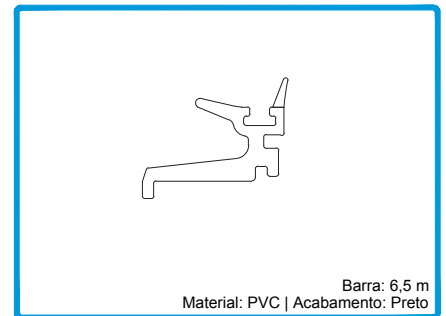

Barra: 6,5 m  
Material: PVC | Acabamento: Preto

**208351** JUNTA CENTRAL 2197 JT-SLIM

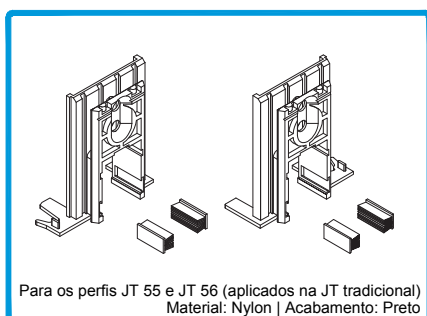

Para os perfis JT 55 e JT 56 (aplicados na JT tradicional)  
Material: Nylon | Acabamento: Preto

**212273** CONJ. TOPOS CENTRAIS Nº1 20MM JT

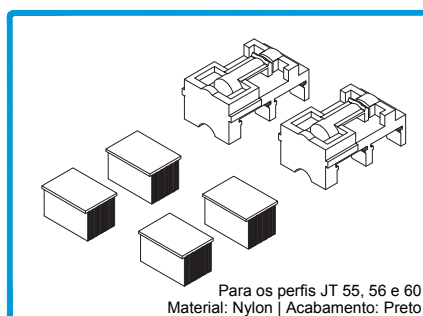

Para os perfis JT 55, 56 e 60  
Material: Nylon | Acabamento: Preto

**212252** CONJ. TOPOS INTERIORES LAT./CENTR. JT-SLIM

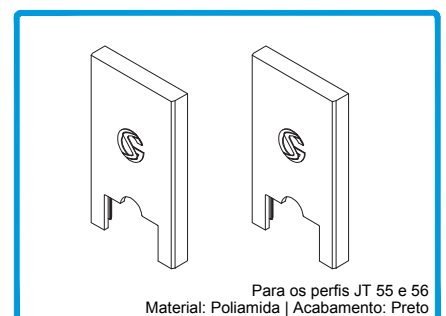

Para os perfis JT 55 e 56  
Material: Poliamida | Acabamento: Preto

**212335** CONJ. TAMPAS TOPOS CENTRAIS JT-SLIM

**Acessórios para ligação central e canto 90°**

Central and 90° corner connection accessories | Accessoires pour le raccordement central et d'angle 90°

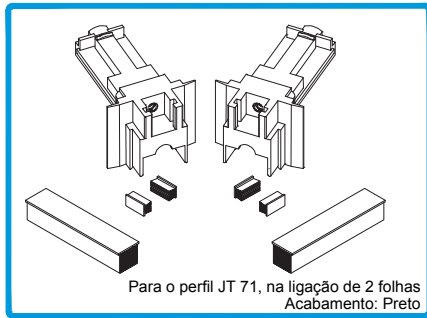

Para o perfil JT 71, na ligação de 2 folhas  
Acabamento: Preto

**212104** CONJ. TOPOS LIGAÇÃO 2 FOLHAS JT

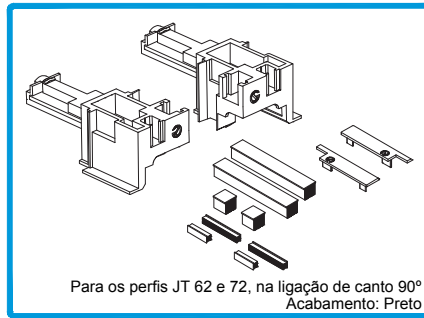

Para os perfis JT 62 e 72, na ligação de canto 90°  
Acabamento: Preto

**212109** CONJ. TOPOS CANTO 90° JT

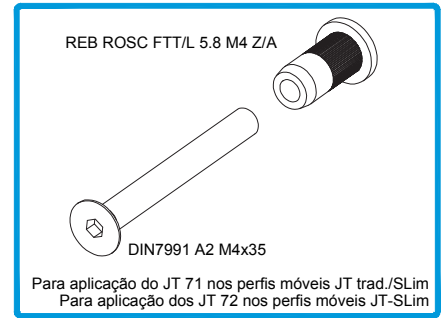

Para aplicação do JT 71 nos perfis móveis JT trad./SLim  
Para aplicação dos JT 72 nos perfis móveis JT-SLim

**212017** CONJUNTO FIXAÇÃO FERRAGEM MULT.

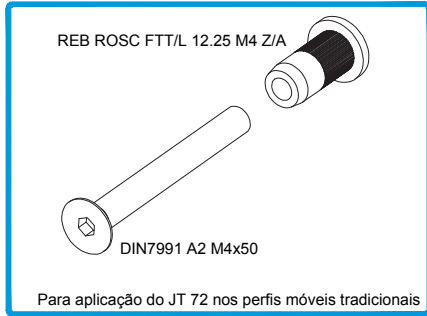

Para aplicação do JT 72 nos perfis móveis tradicionais

**212079** CONJ. FIXAÇÃO FERRAGEM MÚLTIPONTO JT72

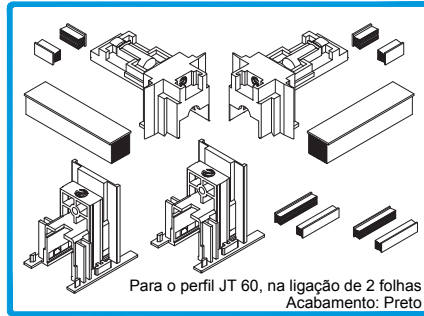

Para o perfil JT 60, na ligação de 2 folhas  
Acabamento: Preto

**212135** CONJ. TOPOS LIGAÇÃO 2 FOLHAS JT-SLIM

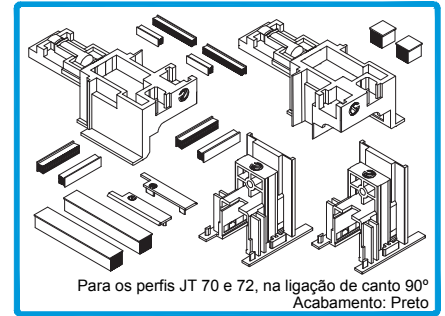

Para os perfis JT 70 e 72, na ligação de canto 90°  
Acabamento: Preto

**212151** CONJ. TOPOS CANTO 90° JT-SLIM

**Acessórios para vidro**

Glass accessories | Accessoires pour verre

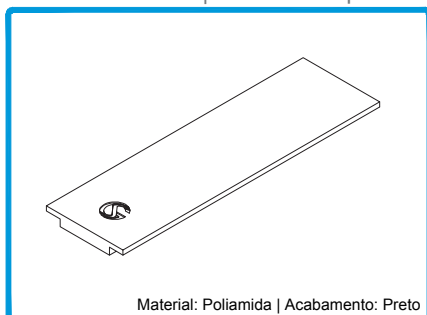

Material: Poliamida | Acabamento: Preto

**218137** CALÇO REFORÇO HORIZONTAL JT

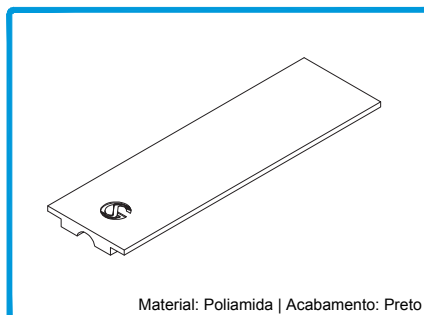

Material: Poliamida | Acabamento: Preto

**218147** CALÇO REFORÇO HORIZ. JT-SLIM

**Pingadeiras**  
Drips | Rejet d'eau

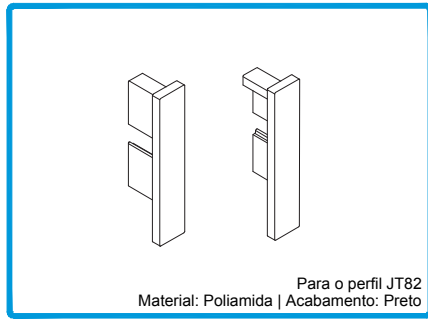

Para o perfil JT82  
Material: Poliamida | Acabamento: Preto

**212384**

CONJ. TOPOS LAT.  
PINGADEIRA JT82

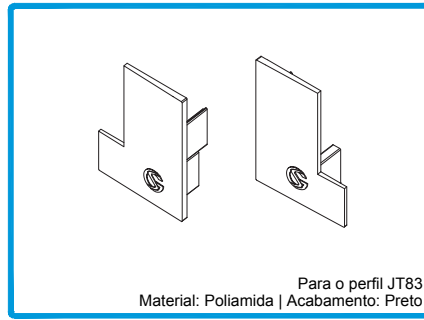

Para o perfil JT83  
Material: Poliamida | Acabamento: Preto

**212341**

CONJ. TOPOS LAT. PINGADEIRA

**Acessórios para Ferragens 1 Ponto e Multiponto**

1 Point and Multipoint hardware accessories | Accessoires pour Serrures 1 Point et Multipoint

	Perfis Profiles   Profils JT Tradicional   Classic   Traditional							Perfis Profiles   Profils JT-Slim
	1 Ponto 1 Point 1 Point	Multiponto Multipoint Multipoint						Multiponto Multipoint Multipoint
	ALU 1P	ALU MAE	ALU MAC	ALU MACK	SOS Centr.	SOS Microv.	SOT	ALU MAC
<b>Acessórios de abertura</b> Opening accessories Access. pour ouverture	201382 ou or   ou 201383	201382 ou or   ou 201383	200817/19 ou or   ou 200959/39	200817/19 ou or   ou 200959/39	200817/19 ou or   ou 200959/39	200811/12 ou or   ou 201083	200238/39	200817/19 ou or   ou 200959/39
<b>Calço para Ferragem</b> Hardware Shim Cale pour Serrure	-	-	-	-	218149	218149	218197	-
<b>Contra-fecho para Aro Fixo</b> Fixed Frame Counter-lock C.-fermeture pour Dormant	202330 + 212455	202330 + 212455	202330 + 212455	202330 + 212455	202491+ + 202487 + 212455	202491+ + 202487 + 212455	202492	202330 + 212455
<b>Contra-fecho p/ ligações no mesmo rail e 90°</b> Same rail and 90° connections counter-lock C.-ferm. pour connexions dans le même rail et 90°	202331 + 212458	202331 + 212458	202331 + 212458	202331 + 212458	202491 + 212458	202491 + 212458	202320	202331 + 212458
<b>Gancho</b> Hook Crochet	204715	204717	-	-	-	-	-	-
<b>Fixação Ferragem</b> Hardware Fixation Fixation de Serrure	-	212371	212371	212371	212371	212371	212371	212373
<b>Cilindro</b> Cylinder Cilindre	-	-	-	230006 ou   or   ou 230040	-	-	230006 ou   or   ou 230040	230006 ou   or   ou 230040
<b>Espelho para Cilindro</b> Cylinder's cover Couverture pour Cilindre	-	-	220196 ou   or   ou 220197	220196 ou   or   ou 220197	-	-	220196 ou   or   ou 220197	220196 ou   or   ou 220197

**Acessórios para Ferragens 1 Ponto e Multiponto - Linha ALU**

1 Point and Multipoint hardware accessories - ALU line | Accessoires pour Serrures 1 Point et Multipoint - Ligne ALU

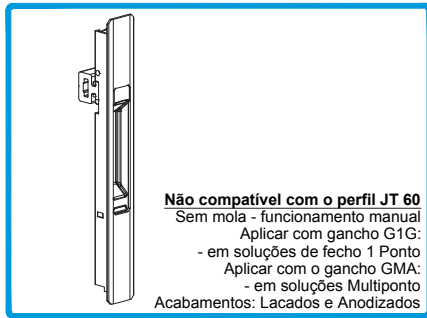

**201382** FECHO DE EMBUTIR R2051X

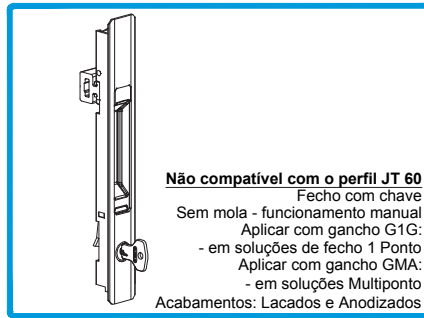

**201383** FECHO DE EMBUTIR C/ CHAVE R2053IX

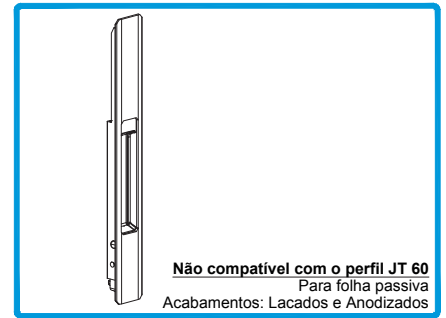

**218211** CONCHA R2043I

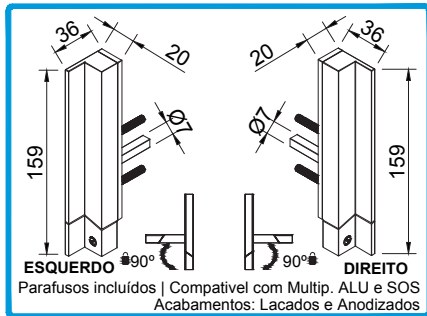

**200817** PUXADOR SLIM XS (Direito)  
**200819** PUXADOR SLIM XS (Esquerdo)

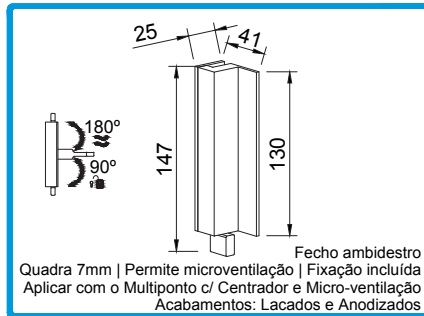

**200811** PUXADOR SLIM XS 180°

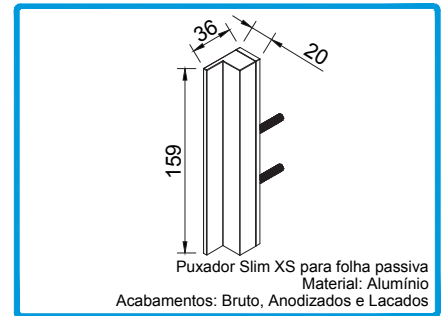

**200057** PUXADOR FOLHA PASSIVA SLIM XS

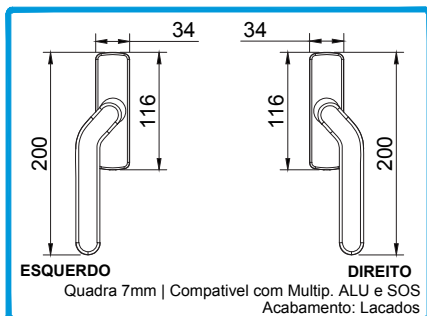

**200959** CREMONE MULT. DESVIADO DIR  
**200939** CREMONE MULT. DESVIADO ESQ

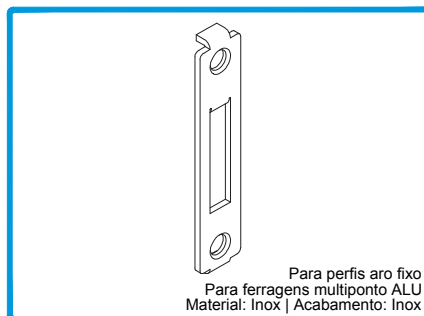

**202330** CONTRA-FECHO ALU

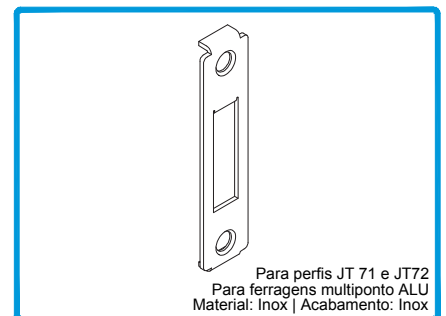

**202331** CONTRA-FECHO Nº2 2F/90° ALU

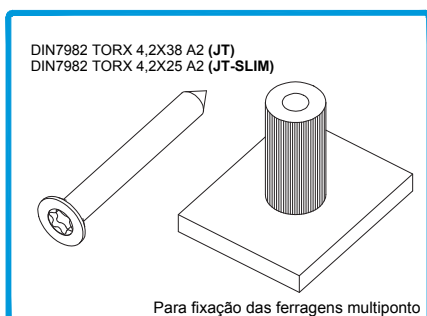

**212371** CONJ. FIXAÇÃO JT  
**212373** CONJ. FIXAÇÃO JT-SLIM

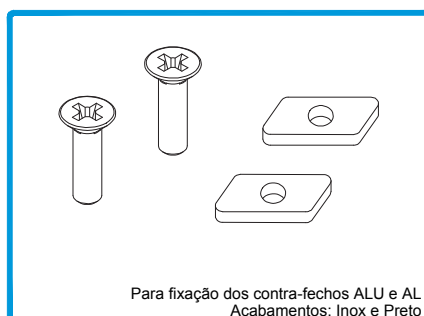

**212455** CONJ. FIX. CONTRA-FECHO AL MULTIP. JT

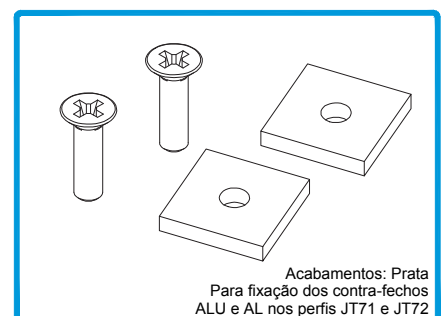

**212458** CONJ. FIX. CONTRA-FECHO 2F/90° JT

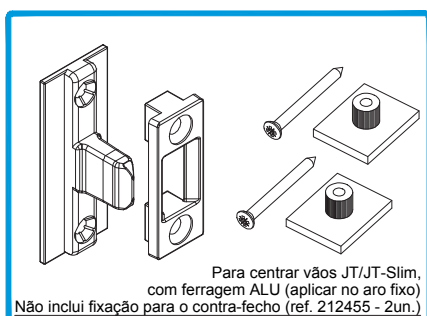

**212289** CONJ. CENTRADOR P/ FERR. ALU

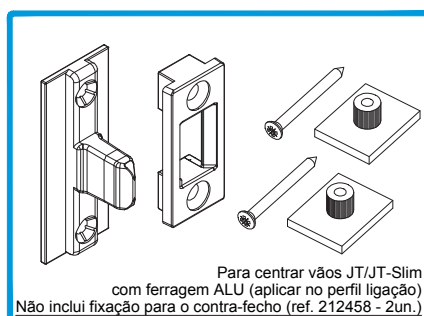

**212291** CONJ. CENTRADOR P/ FERR. ALU PERFIL LIG.

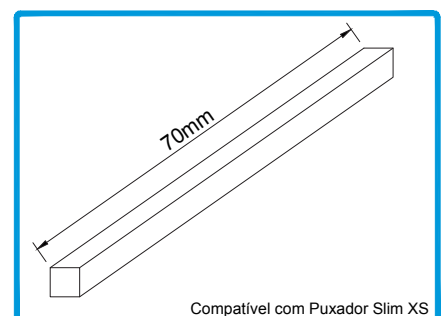

**227305** QUADRA AÇO 7MMx70

**Acessórios para Ferragens 1 Ponto e Multiponto - Linha ALU**

1 Point and Multipoint hardware accessories - ALU line | Accessoires pour Serrures 1 Point et Multipoint - Ligne ALU

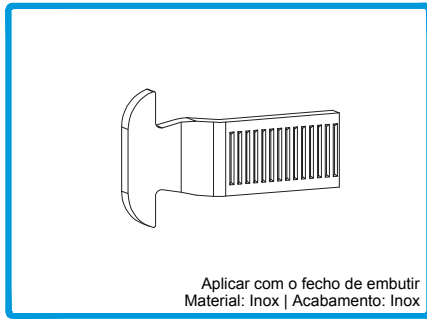

Aplicar com o fecho de embutir  
Material: Inox | Acabamento: Inox

**204715** GANCHO LIG. G1G

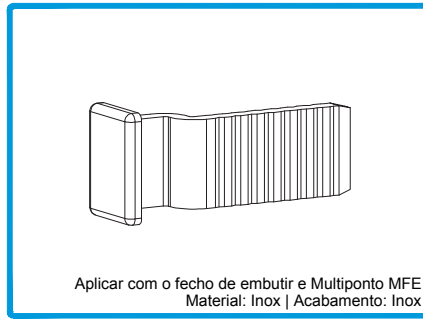

Aplicar com o fecho de embutir e Multiponto MFE  
Material: Inox | Acabamento: Inox

**204717** GANCHO LIG. MULTIPONTO GMA

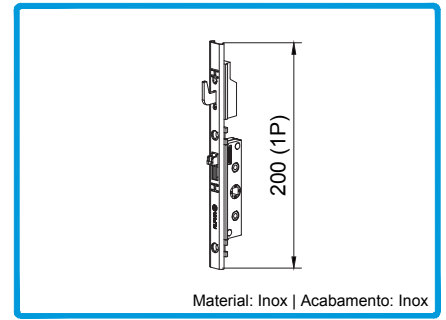

Material: Inox | Acabamento: Inox

**211036** PONTO-FECHO ALU MAC.200 (1P)

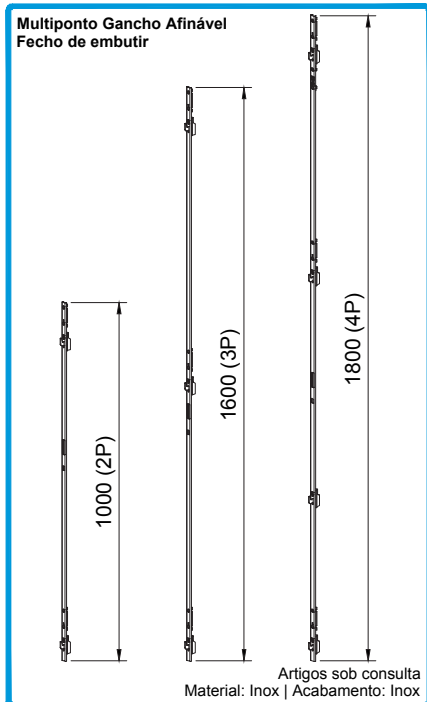

Artigos sob consulta  
Material: Inox | Acabamento: Inox

**211237** MULTIPONTO ALU MAE.1000 (2P)  
**211238** MULTIPONTO ALU MAE.1600 (3P)  
**211239** MULTIPONTO ALU MAE.1800 (4P)

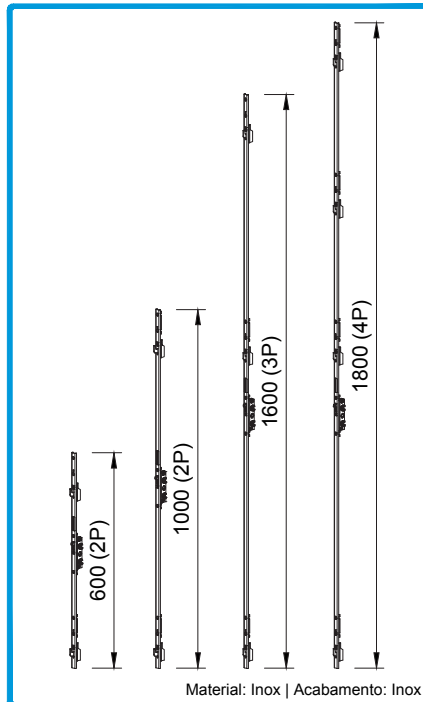

Material: Inox | Acabamento: Inox

**211233** MULTIPONTO ALU MAC.600 (2P)  
**211234** MULTIPONTO ALU MAC.1000 (2P)  
**211235** MULTIPONTO ALU MAC.1600 (3P)  
**211236** MULTIPONTO ALU MAC.1800 (4P)

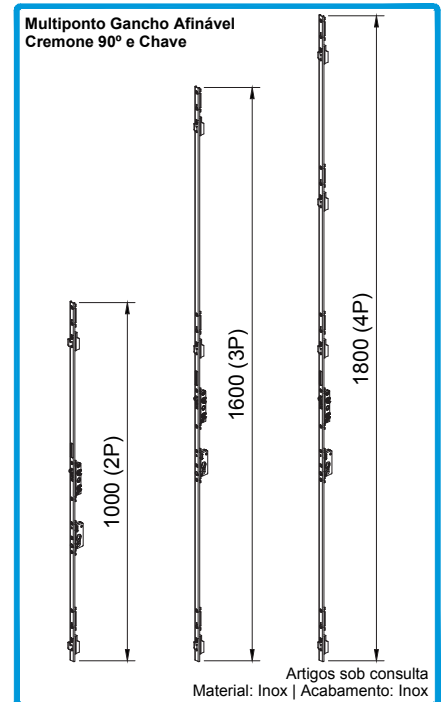

Artigos sob consulta  
Material: Inox | Acabamento: Inox

**211240** MULTIPONTO ALU MACK.1000 (2P)  
**211241** MULTIPONTO ALU MACK.1600 (3P)  
**211242** MULTIPONTO ALU MACK.1800 (4P)

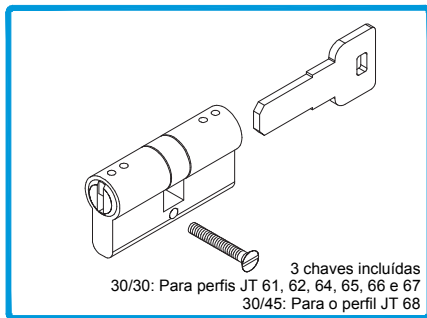

3 chaves incluídas  
30/30: Para perfis JT 61, 62, 64, 65, 66 e 67  
30/45: Para o perfil JT 68

**230006** SEGREDO 30/30 NIQUELADO  
**230040** SEGREDO 30/45

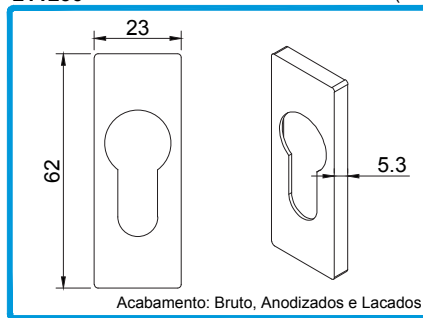

Acabamento: Bruto, Anodizados e Lacados

**220196** ESPELHO ALUMÍNIO 23MM P/ SEGREDO

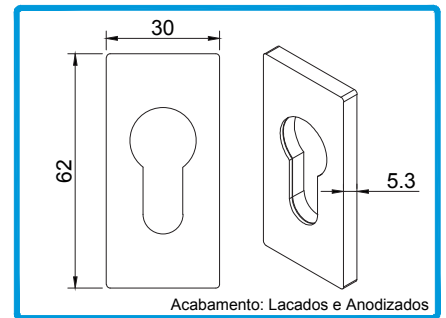

Acabamento: Lacados e Anodizados

**220197** ESPELHO ALUMÍNIO 30MM P/ SEGREDO

**Acessórios para Ferragens 1 Ponto e Multiponto - Linha SOS**

1 Point and Multipoint hardware accessories - SOS line | Accessoires pour Serrures 1 Point et Multipoint - Ligne SOS

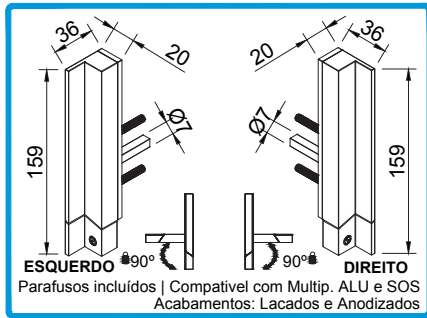

**200817** PUXADOR SLIM XS (Direito)  
**200819** PUXADOR SLIM XS (Esquerdo)  
Parafusos incluídos | Compatível com Multip. ALU e SOS  
Acabamentos: Lacados e Anodizados

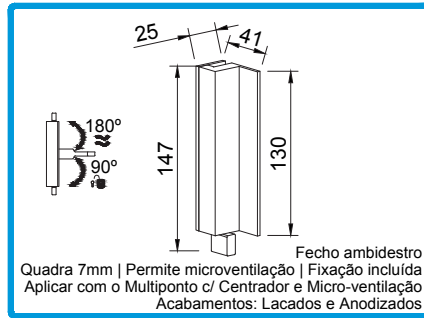

**200811** PUXADOR SLIM XS 180°  
Quadra 7mm | Permite microventilação | Fixação incluída  
Aplicar com o Multiponto c/ Centrador e Micro-ventilação  
Acabamentos: Lacados e Anodizados

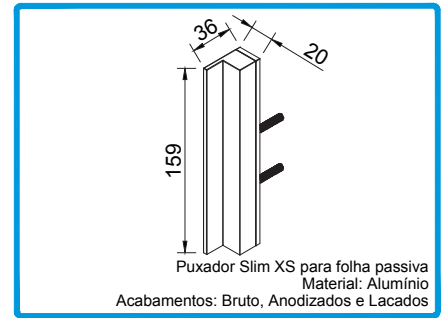

**200057** PUXADOR FOLHA PASSIVA SLIM XS  
Puxador Slim XS para folha passiva  
Material: Alumínio  
Acabamentos: Bruto, Anodizados e Lacados

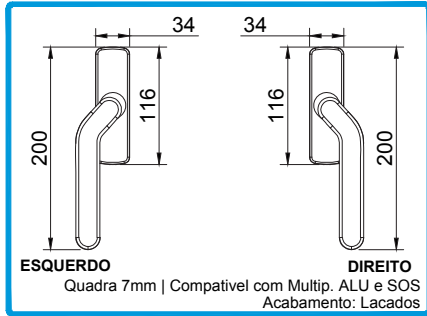

**200959** CREMONE MULT. DESVIADO DIR  
**200939** CREMONE MULT. DESVIADO ESQ  
Quadra 7mm | Compatível com Multip. ALU e SOS  
Acabamento: Lacados

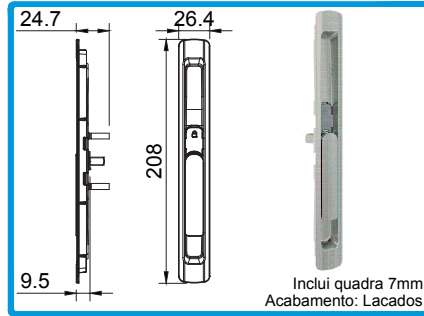

**201083** FECHO DE EMBUTIR 180°  
Inclui quadra 7mm  
Acabamento: Inox

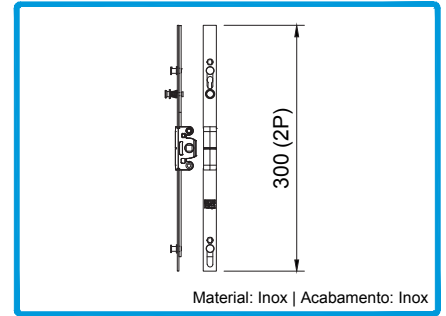

**211119** F. MULTIP. ANTI-FALSA MAN. 300  
Material: Inox | Acabamento: Inox

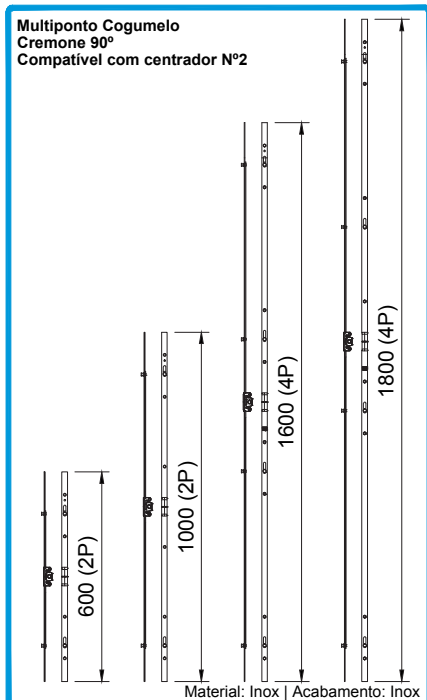

**211222** F. MULTIP. CENTR. 600 (2P)  
**211223** F. MULTIP. CENTR. 1000 (2P)  
**211224** F. MULTIP. CENTR. 1600 (4P)  
**211225** F. MULTIP. CENTR. 1800 (4P)  
Material: Inox | Acabamento: Inox

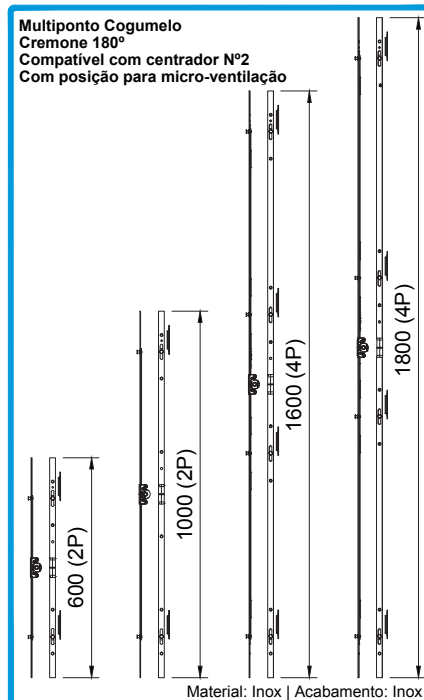

**211227** F. MULTIP. CENTR. C/VENT. 600 (2P)  
**211228** F. MULTIP. CENTR. C/VENT. 1000 (2P)  
**211229** F. MULTIP. CENTR. C/VENT. 1600 (4P)  
**211230** F. MULTIP. CENTR. C/VENT. 1800 (4P)  
Material: Inox | Acabamento: Inox

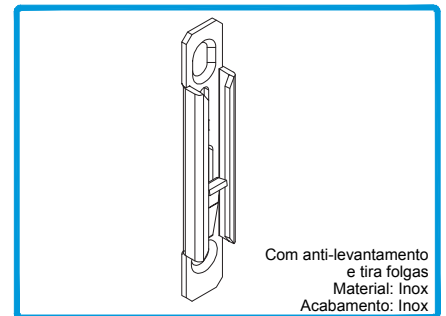

**202491** CONTRA-FECHO ANTI-LEV. MULT.  
Com anti-levantamento e tira folgas  
Material: Inox  
Acabamento: Inox

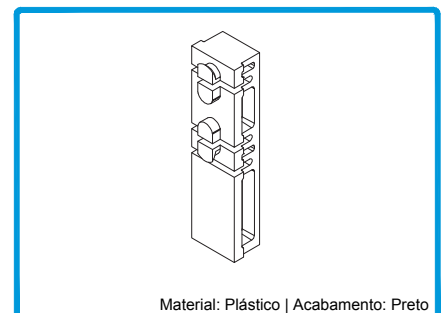

**202487** CENTRADOR JT P/ C-FECHO AL M.  
Material: Plástico | Acabamento: Preto

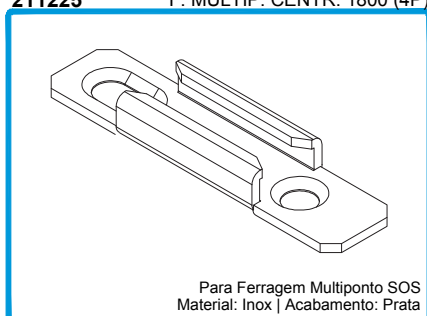

**202496** CONTRA-FECHO PEQ. MULTIP. SOS INOX  
Para Ferragem Multiponto SOS  
Material: Inox | Acabamento: Prata



**212455** CONJ. FIX. CONTRA-FECHO AL MULTIP. JT  
Para fixação dos contra-fechos ALU e AL  
Acabamentos: Inox e Preto

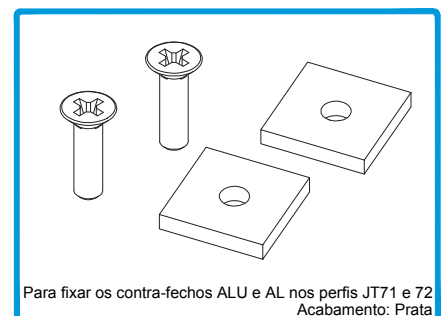

**212458** CONJ. FIX. CONTRA-FECHO 2F/90° JT  
Para fixar os contra-fechos ALU e AL nos perfis JT71 e 72  
Acabamento: Prata

**Acessórios para Ferragens 1 Ponto e Multiponto - Linha SOS**

1 Point and Multipoint hardware accessories - SOS line | Accessoires pour Serrures 1 Point et Multipoint - Ligne SOS

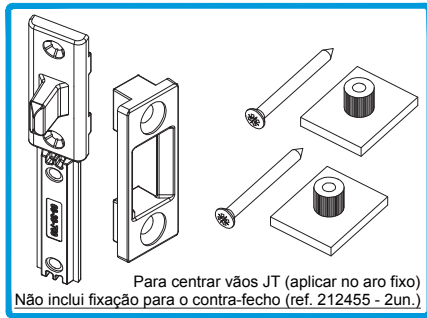

Para centrar vãos JT (aplicar no aro fixo)  
Não inclui fixação para o contra-fecho (ref. 212455 - 2un.)

**212161** CONJ. CENTRADOR P/ FERRAGEM JT

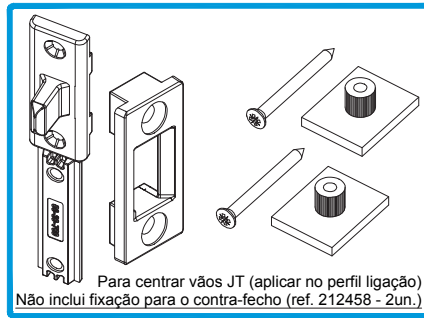

Para centrar vãos JT (aplicar no perfil ligação)  
Não inclui fixação para o contra-fecho (ref. 212458 - 2un.)

**212162** CONJ. CENTRADOR P/ FERRAGEM JT PERFIL LIG.

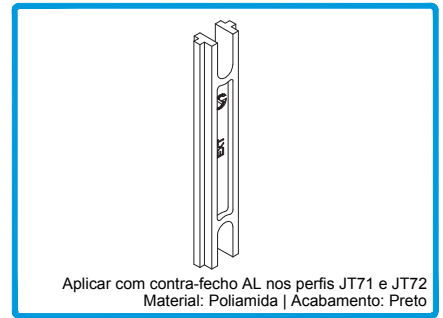

Aplicar com contra-fecho AL nos perfis JT71 e JT72  
Material: Poliamida | Acabamento: Preto

**218154** CALÇO P/ CONTRA-FECHO AL MULTIP. PERFIL LIG

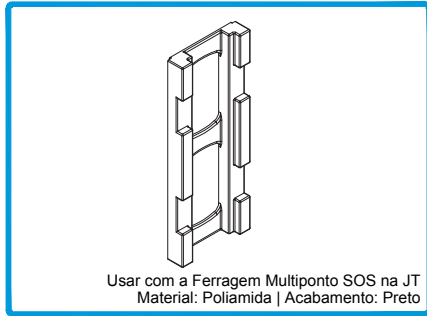

Usar com a Ferragem Multiponto SOS na JT  
Material: Poliamida | Acabamento: Preto

**218149** CALÇO Nº2 P/ MULTIP. SOS JT

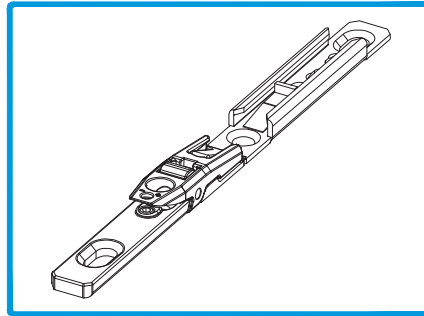

**299217** MICRO-VENTILAÇÃO P/ MULT. CENTR. C/ VENT.

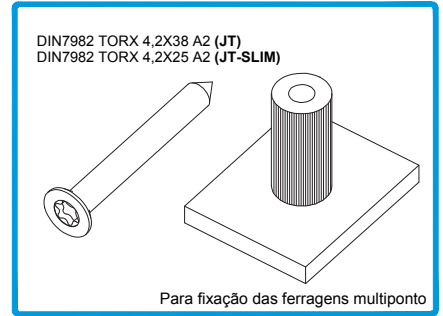

DIN7982 TORX 4.2X38 A2 (JT)  
DIN7982 TORX 4.2X25 A2 (JT-SLIM)

Para fixação das ferragens multiponto

**212371** CONJ. FIXAÇÃO JT  
**212373** CONJ. FIXAÇÃO JT-SLIM

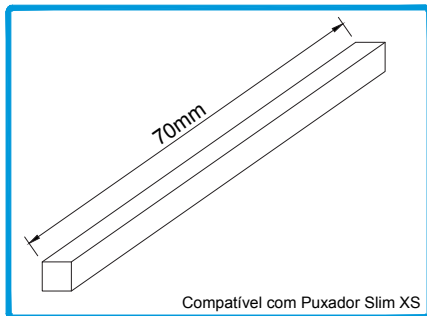

Compatível com Puxador Slim XS

**227305** QUADRA AÇO 7MMx70

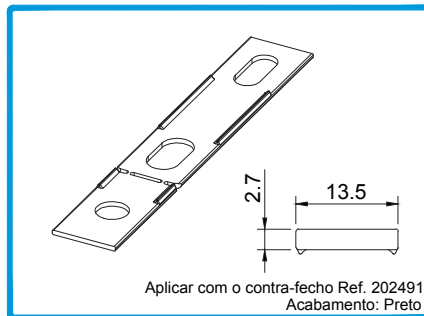

Aplicar com o contra-fecho Ref. 202491  
Acabamento: Preto

**218162** CALÇO 3MM P/ CONTRA-FECHO AL MULT.

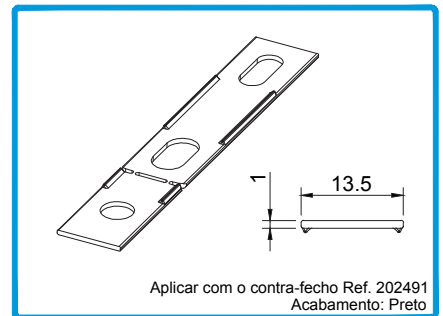

Aplicar com o contra-fecho Ref. 202491  
Acabamento: Preto

**218165** CALÇO 1MM P/ CONTRA-FECHO AL MULT.

**Acessórios para Ferragens 1 Ponto e Multiponto - Linha SOT**

1 Point and Multipoint hardware accessories - SOT line | Accessoires pour Serrures 1 Point et Multipoint - Ligne SOT

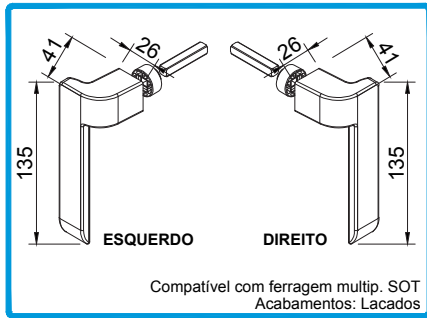

Compatível com ferragem multip. SOT  
Acabamentos: Lacados

- 200238** CREM. MULTIP. MINIMALISTA NOVEM DESV. SOT - DIR
- 200239** CREM. MULTIP. MINIMALISTA NOVEM DESV. SOT - ESQ

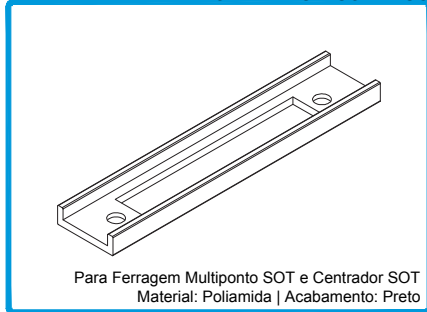

Para Ferragem Multiponto SOT e Centrador SOT  
Material: Poliamida | Acabamento: Preto

- 218197** CALÇO P/ MULTIPONTO SOT JT

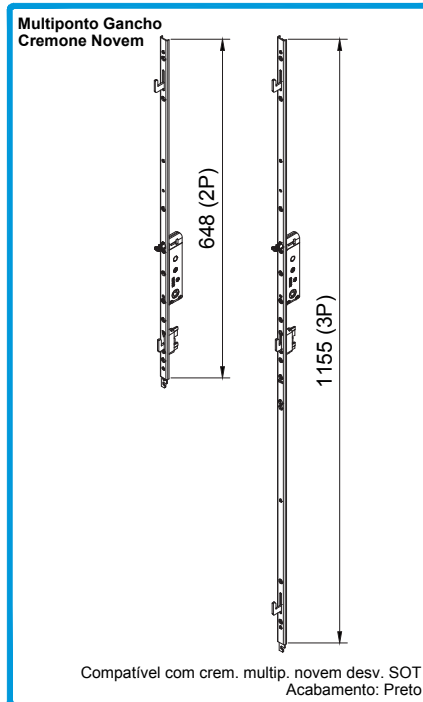

Compatível com crem. multip. novem desv. SOT  
Acabamento: Preto

- 211175** F. MULT. CHRONOS EVO SOT (2P)
- 211176** F. MULT. CHRONOS EVO SOT (3P)

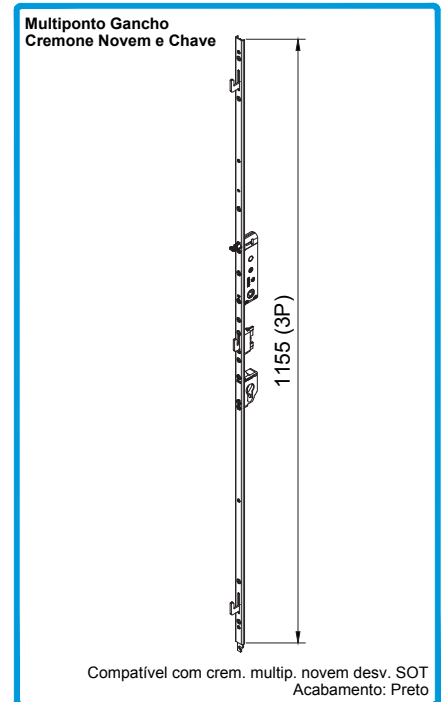

Compatível com crem. multip. novem desv. SOT  
Acabamento: Preto

- 211179** FERRAGEM MULTIP. C/ CHAVE CHRONOS EVO SOT (3P)

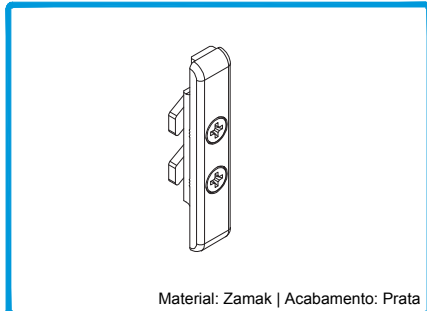

Material: Zamak | Acabamento: Prata

- 202492** CONTRA-FECHO SOT

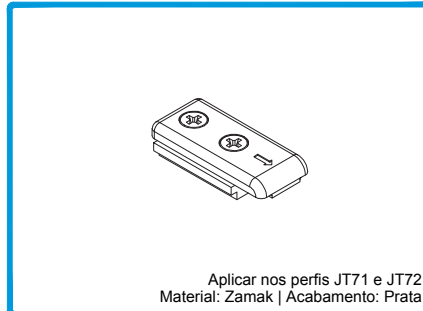

Aplicar nos perfis JT71 e JT72  
Material: Zamak | Acabamento: Prata

- 202320** CONTRA FECHO LIGAÇÃO 2 FOLHAS E 90° SOT

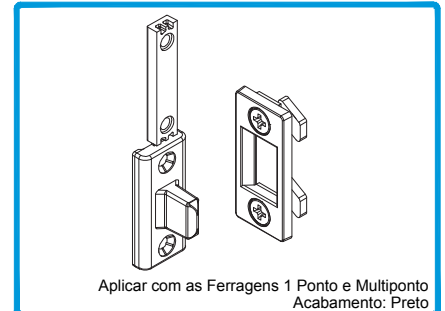

Aplicar com as Ferragens 1 Ponto e Multiponto  
Acabamento: Preto

- 202495** CENTRADOR SOT

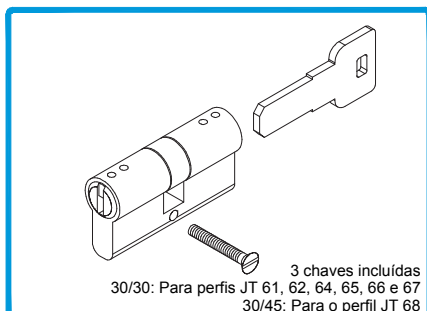

3 chaves incluídas  
30/30: Para perfis JT 61, 62, 64, 65, 66 e 67  
30/45: Para o perfil JT 68

- 230006** SEGREDO 30/30 NIQUELADO
- 230040** SEGREDO 30/45

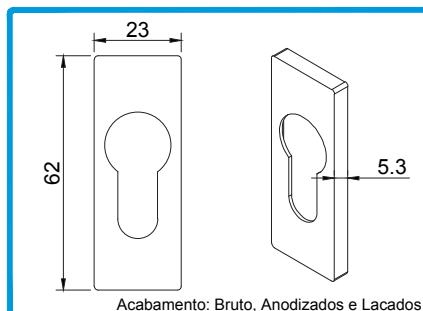

Acabamento: Bruto, Anodizados e Lacados

- 220196** ESPELHO ALUMÍNIO 23MM P/ SEGREDO

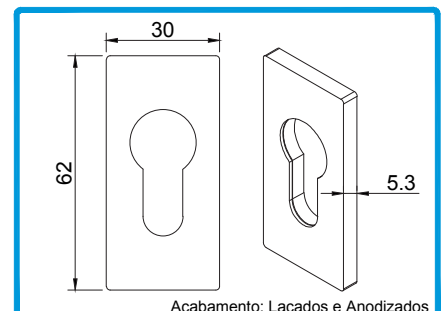

Acabamento: Lacados e Anodizados

- 220197** ESPELHO ALUMÍNIO 30MM P/ SEGREDO



**Acessórios para mosquiteira**

Mosquito net accessories | Accessoires pour mosquiteira

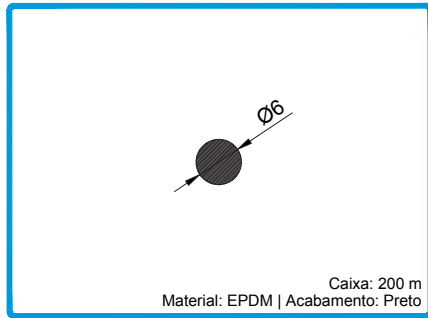

Caixa: 200 m  
Material: EPDM | Acabamento: Preto

**208310** VEDANTE P/ MOSQUITEIRA 1027

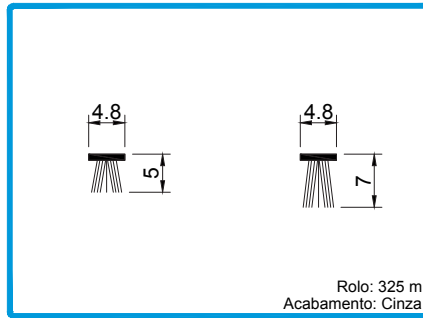

Rolo: 325 m  
Acabamento: Cinza

**208303** PELUCIA 4.8x5MM P/ MOSQUITEIRA  
**208564** PELUCIA 4.8x7MM P/ MOSQUITEIRA

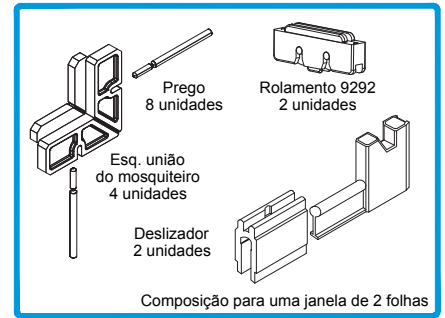

Composição para uma janela de 2 folhas

**223247** KIT TR MOSQUITEIRA DE CORRER

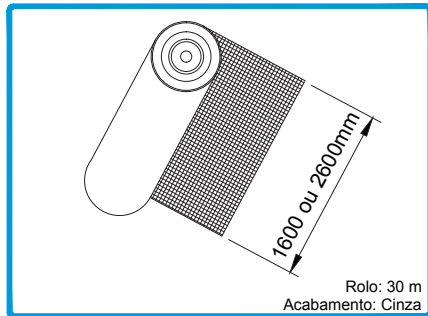

Rolo: 30 m  
Acabamento: Cinza

**229105** REDE MOSQ. EM FIBRA 1600mm  
**229106** REDE MOSQ. EM FIBRA 2600mm

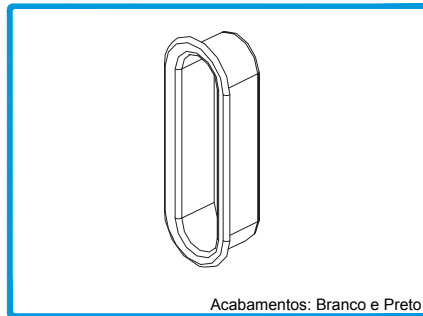

Acabamentos: Branco e Preto

**218214** CONCHA PLÁSTICA NYLON

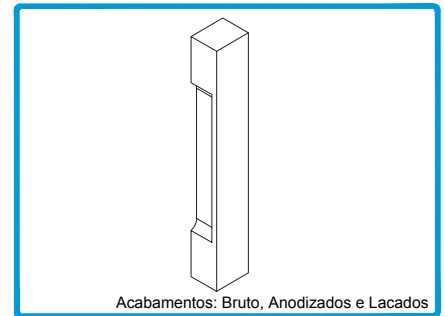

Acabamentos: Bruto, Anodizados e Lacados

**200056** PUXADOR FIXO SLIM

**Acessórios Renovatio**

Renovatio accessories | Accessoires Renovatio

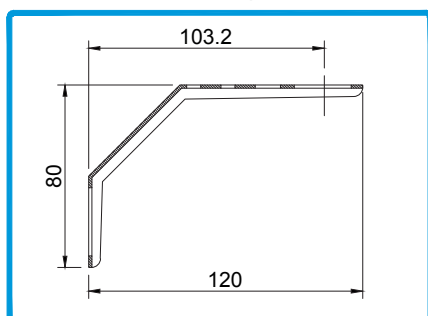

**213240** ÂNGULO DE FIXAÇÃO 120MM

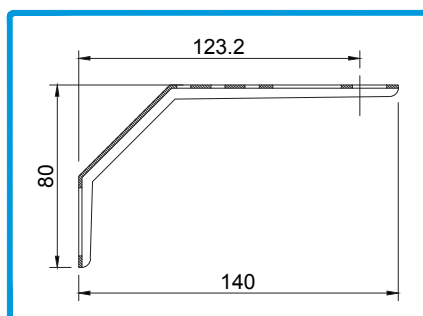

**213256** ÂNGULO DE FIXAÇÃO 140MM

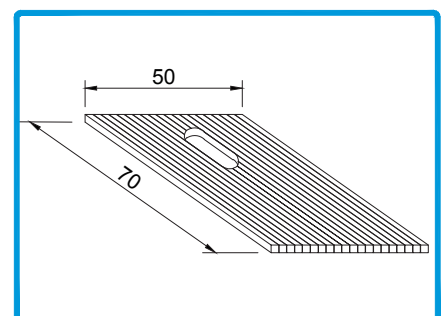

**218116** CALÇO SEPARADOR 50x70MM

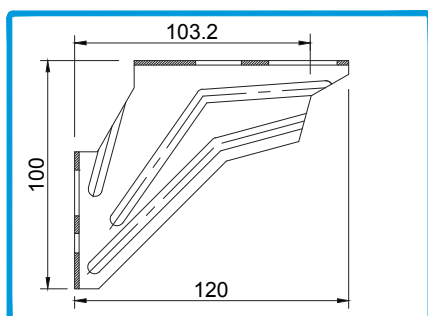

**230019** SUPORTE DE FIXAÇÃO 120MM

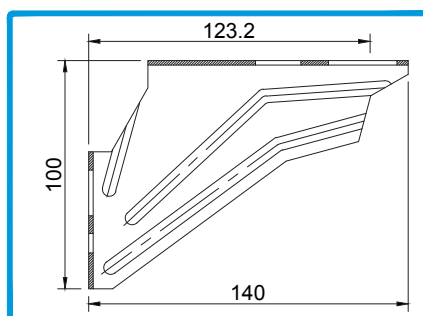

**230308** SUPORTE DE FIXAÇÃO 140MM

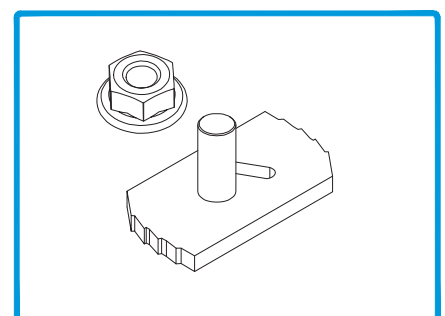

**207220** PRESILHA M6x37MM

**Acessórios Renovatio**

Renovatio accessories | Accessoires Renovatio

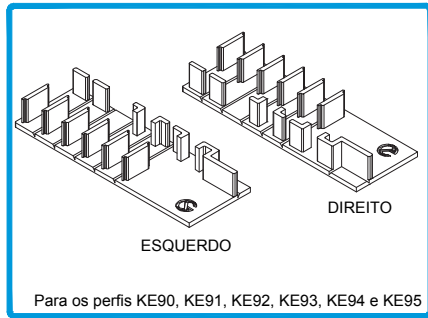

Para os perfis KE90, KE91, KE92, KE93, KE94 e KE95

**212223** CONJ. TOPOS INFERIORES RENOVIATIO

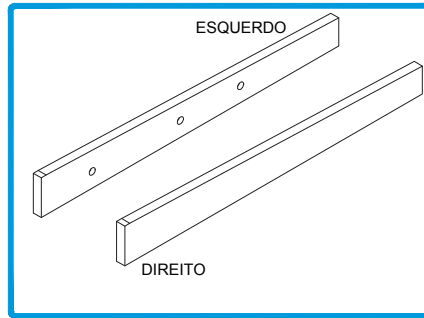

**212227** CONJ. JUNTAS ADESIVAS P/ TOPOS PERFIL SOLEIRA KE71

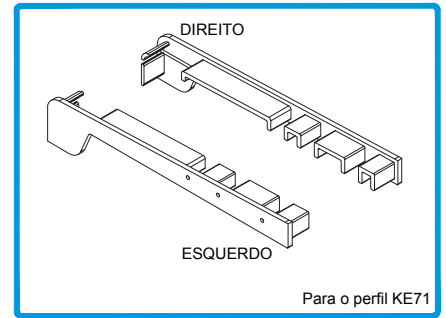

Para o perfil KE71

**212221** CONJUNTO TAPA TOPOS KE 71

**Ferramentas**

Tools | Outils

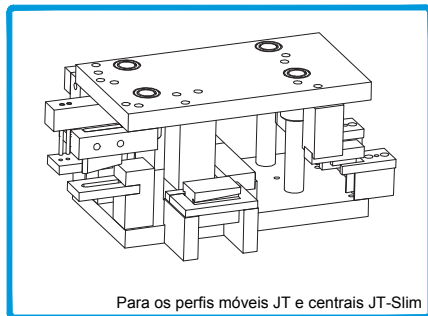

Para os perfis móveis JT e centrais JT-Slim

**408060** CORTANTE JT - FOLHAS

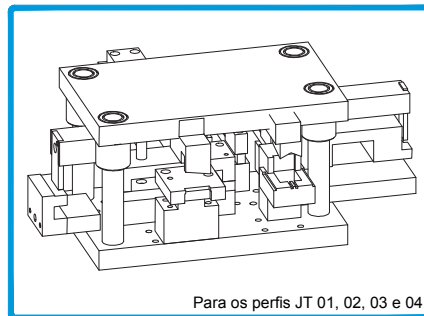

Para os perfis JT 01, 02, 03 e 04

**408061** CORTANTE JT - AROS FR

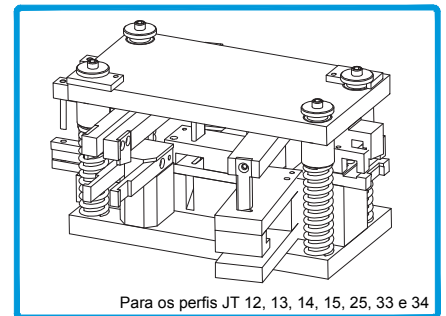

Para os perfis JT 12, 13, 14, 15, 25, 33 e 34

**408062** CORTANTE JT - AROS PT

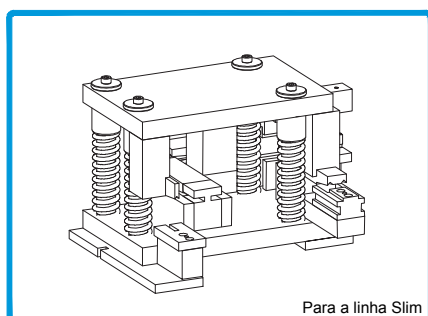

Para a linha Slim

**408064** CORTANTE JT-SLIM - FOLHA

**Diversos**  
Various | Divers

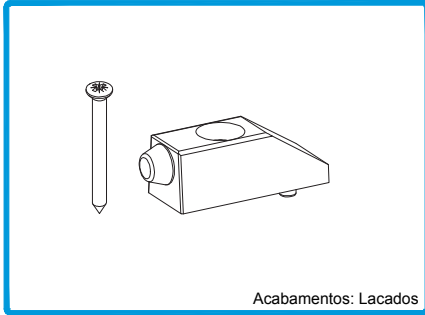

Acabamentos: Lacados  
**228107** LIMITADOR ABERTURA PQ SERIE CORRER



Para afinação da folga das folhas móveis  
Material: ABS | Acabamento: Preto  
**211006** GABARITO AFINAÇÃO FOLHAS JT

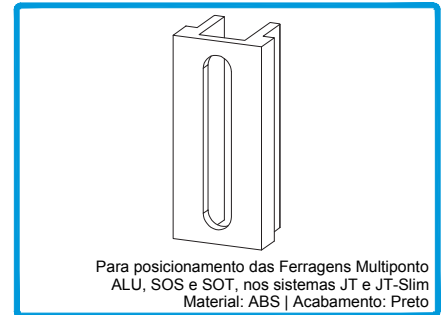

Para posicionamento das Ferragens Multiponto ALU, SOS e SOT, nos sistemas JT e JT-Slim  
Material: ABS | Acabamento: Preto  
**211007** GABARITO POSICION. MULTIP. JT

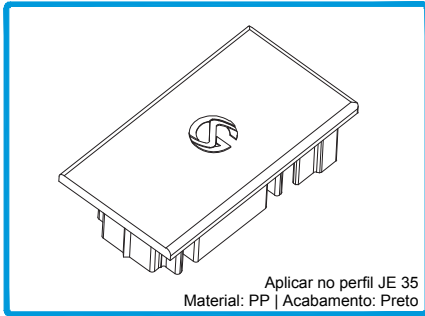

Aplicar no perfil JE 35  
Material: PP | Acabamento: Preto  
**211069** TOPO JE 35 PRT



Junta de vedação elástica, resistente aos UV. Impede a corrosão de penetrar pelas zonas cortadas  
**208019** SELA JUNTAS 150gr. (Cinza)



Limpeza de alumínio lacado ou anodizado. Para preparação de superfícies a serem unidas e limpeza final  
**208704** PRODUTO LIMPEZA DE ALUMÍNIO (1L) Transparente

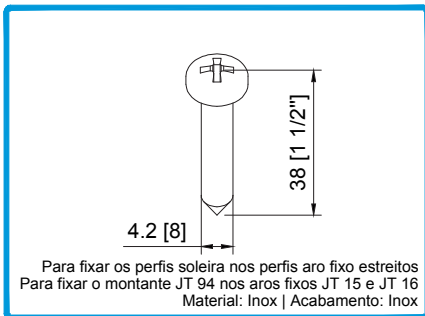

Para fixar os perfis soleira nos perfis aro fixo estreitos  
Para fixar o montante JT 94 nos aros fixos JT 15 e JT 16  
Material: Inox | Acabamento: Inox  
**290030** PARAF. DIN981 4,2x38 INOX A2

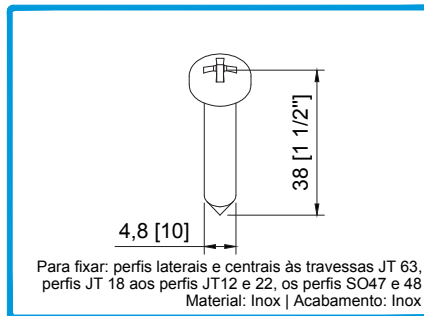

Para fixar: perfis laterais e centrais às travessas JT 63, perfis JT 18 aos perfis JT12 e 22, os perfis SO47 e 48  
Material: Inox | Acabamento: Inox  
**290262** PARAF. PAR 003 PK INOX PH 1 1/2x10 CQ

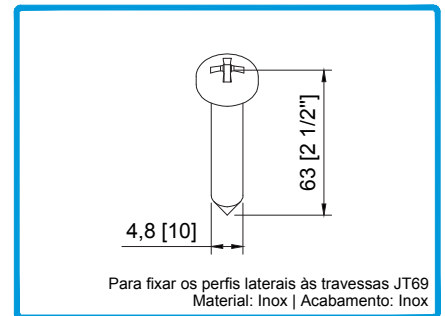

Para fixar os perfis laterais às travessas JT69  
Material: Inox | Acabamento: Inox  
**290087** PARAF. DIN981 PH 4,8x63 INOX A2

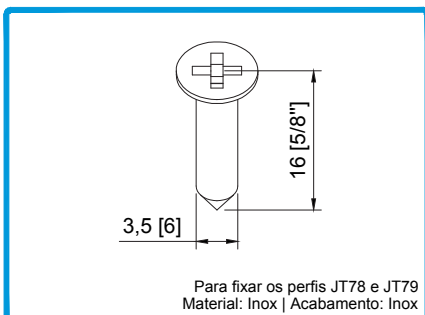

Para fixar os perfis JT78 e JT79  
Material: Inox | Acabamento: Inox  
**290052** PARAF. DIN982 PH 3,5x16 INOX A2

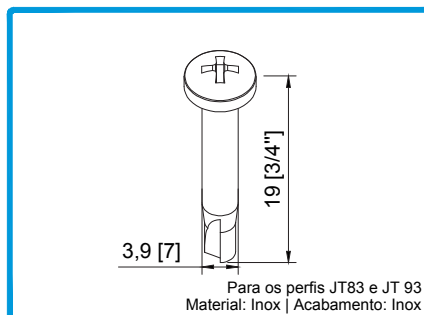

Para os perfis JT83 e JT 93  
Material: Inox | Acabamento: Inox  
**290472** PARAF. AT/PF CQ Ø3.9x19MM A2

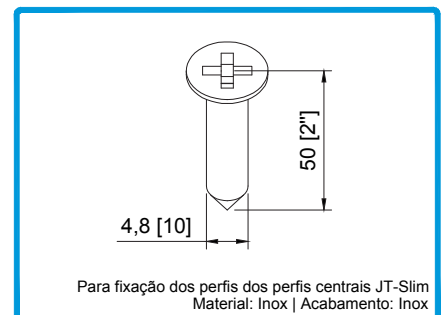

Para fixação dos perfis dos perfis centrais JT-Slim  
Material: Inox | Acabamento: Inox  
**290091** PARAFUSO DIN982 PH 4,8x50 A2

# IV

## TIPOLOGIAS E MAPAS DE QUANTIDADES TYPOLOGIES AND QUANTITY MAPS | TYPOLOGIES ET CARTES DE QUANTITÉS

- **SISTEMA | SYSTEM | SYSTÈME JT**

PERFIS ARO FIXO FR (CORTE 45°) FR FIXED FRAME PROFILES (45° CUT)   PROFILÉS CADRE DORMANT FR (COUPE 45°)	IV.1
PERFIS ARO FIXO PT (CORTE 45°) PT FIXED FRAME PROFILE (45° CUT)   PROFILÉS CADRE DORMANT PT (COUPE 45°)	IV.2
PERFIL LINHA SOLEIRA 30MM (CORTE 90°) 30MM SILL PROFILE (90° CUT)   PROFILÉ SEUIL 30MM (COUPE 90°)	IV.3
TIPOLOGIAS COM FIXOS INTERIORES TYPOLOGIES WITH INSIDE FIXES   TYPOLOGIES AVEC FIXES INTÉRIEURES	IV.4
TIPOLOGIAS COM FIXOS EXTERIORES TYPOLOGIES WITH OUTSIDE FIXES   TYPOLOGIES AVEC FIXES EXTÉRIEURES	IV.5
TIPOLOGIAS COM MOSQUITEIRA TYPOLOGIES WITH MOSQUITO NET   TYPOLOGIES AVEC MOUSTIQUAIRE	IV.6
TIPOLOGIAS COM SOLUÇÃO RENOVATIO TYPOLOGIES WITH RENOVATIO SOLUTIONS   TYPOLOGIES AVEC SOLUTIONS RENOVATIO	IV.7

- **SISTEMA | SYSTEM | SYSTÈME JT-SLIM**

PERFIS ARO FIXO FR (CORTE 45°) FR FIXED FRAME PROFILES (45° CUT)   PROFILÉS CADRE DORMANT FR (COUPE 45°)	IV.8
PERFIS ARO FIXO PT (CORTE 45°) PT FIXED FRAME PROFILE (45° CUT)   PROFILÉS CADRE DORMANT PT (COUPE 45°)	IV.9
PERFIL LINHA SOLEIRA 30MM (CORTE 90°) 30MM SILL PROFILE (90° CUT)   PROFILÉ SEUIL 30MM (COUPE 90°)	IV.10

- **COMBINAÇÃO JT + CENTRAL 20mm | JT + 20mm CENTRAL PROFILE COMBINATION |  
COMBINAISON JT + PROFILÉ CENTRAL 20mm**

PERFIS ARO FIXO FR (CORTE 45°) FR FIXED FRAME PROFILES (45° CUT)   PROFILÉS CADRE DORMANT FR (COUPE 45°)	IV.11
PERFIS ARO FIXO PT (CORTE 45°) PT FIXED FRAME PROFILE (45° CUT)   PROFILÉS CADRE DORMANT PT (COUPE 45°)	IV.12
PERFIL LINHA SOLEIRA 30MM (CORTE 90°) 30MM SILL PROFILE (90° CUT)   PROFILÉ SEUIL 30MM (COUPE 90°)	IV.13

**JANELA DE CORRER 2 FOLHAS 2-RAIL- LINHA FR**  
2 SASHES 2-RAIL SLIDING WINDOW - FR LINE  
FENÊTRE COULISSANT 2 VANT AUX 2-RAIL - LIGNE FR

PERFIS   PROFILES   PROFILÉS					
CÓDIGO CODE   CODE	DESIGNAÇÃO DESIGNATION   NOMINATION	CORTE HORIZ. HORIZONTAL CUT COUPE HORIZ.	CORTE VERT. VERTICAL CUT COUPE VERTICALE	QUANT. QUANTITY QUANTITÉ	CORTE CUT COUPE
JT 02	ARO FIXO FIXED FRAME   CADRE DORMANT	L	H	2 + 2	
JT 54	PERFIL CENTRAL CENTRAL PROFILE   PROFILÉ CENTRAL	-	H-81	2	
JT 68	PERFIL LATERAL LATERAL PROFILE   PROFILÉ LATÉRAL	-	H-81	2	
JT 63	TRAVESSA SUP/INF UP/LW TRANSOM   TRAVERSE SUP/INF	(L-202)/2	-	4	
AT 30	CAPA COVER   CAPOT	L-44	-	1	
JT 83	PERFIL PINGADEIRA DRIP PROFILE   L'ARMIER	L-44	-	1	
JT 85	CAPA COVER   CAPOT	-	H-58	2	
JT 87	GUIA GUIDE   GUIDE	L-100	-	2	
208346	JUNTA CENTRAL 2196 CENTRAL JOINT   JOINT CENTRALE	-	H-81	2	
215305	PERFIL PVC U U PVC PROFILE   PROFILÉ PVC U	L-41	H-41	2 + 2	
215303	PERFIL PVC T T PVC PROFILE   PROFILÉ PVC T	(L-137)/2	H-44	2 + 2	

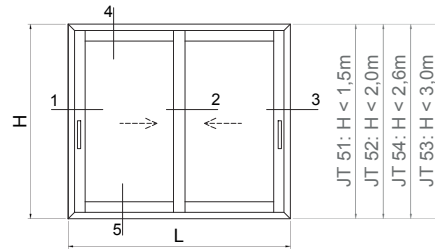

DESEMPENHO DO SISTEMA SYSTEM PERFORMANCE PERFORMANCE DU SYSTÈME	
Permeabilidade ao AR AIR Permeability Perméabilité à l'AIR	3
Estanteidade à ÁGUA WATER Tightness Étanchéité à l'EAU	7A
Resistência ao VENTO WIND Resistance Résistance au VENT	C5

ACESSÓRIOS   ACCESSORIES   ACCESSOIRES		
CÓDIGO CODE   CODE	DESIGNAÇÃO DESIGNATION   NOMINATION	QUANT. QUANTITY QUANTITÉ
205129	CARRINHO JT 180KG ROLLER   ROULETTE	4
213286	CORTA-VENTO JT CENTRAL WATERPROOFING PILE SEAL   BROSSSE CENTRALE D'ÉTANCHÉITÉ	2
212337	CONJ. ESTANQ. CORTA-VENTO JT CENTRAL WATERPROOFING PILE SEAL KIT   KIT BROSSSE CENTRALE D'ÉTANCHÉITÉ	1
204164	ESQUADRO JT 12x9,5 CORNER CLEAN   ÉQUERRE	8
213014	CANTO ALINHAMENTO JT ALIGNMENT CORNER   ANGLE D'ALIGNEMENT	4
213246	CANTO CR S/SB CORNER   ANGLE	4
212199	CONJ. TOPOS LAT. JT LATERAL END-CAPS KIT   KIT D'EMBOUTS LATÉRAUX	2
212230	CONJ. TOPOS INTERIOR LAT. JT LATERAL INNER END-CAPS KIT   KIT D'EMBOUTS INTÉRIEUR LATÉRAUX	2
212201	CONJ. TAMPAS TOPOS LAT. JT LATERAL END-CAP COVERS KIT   KIT DE COUVERTURE POUR EMBOUTS LATÉRAUX	2
210288	TOPO LATERAL JT68 28MM 28MM JT68 LATERAL END-CAPS KIT   KIT D'EMBOUTS LATÉRAUX JT68 28MM	4
212231	CONJ. TOPOS CENTRAIS JT CENTRAL END-CAPS KIT   KIT D'EMBOUTS CENTRAUX	2
212339	CONJ. TAMPAS TOPOS CENTRAIS JT CENTRAL END-CAP COVERS KIT   KIT DE COUVERTURE POUR EMBOUTS CENTRAUX	2
210243	TOPO CENTRAL REFORÇADO JT54 28MM 28MM CENTRAL REINFORCED END-CAPS KIT   KIT D'EMBOUTS CENTRAUX RENFORCÉ 28MM	4
210269	GOTEIRA OCULTA C/ VAL V. SV-C13 FLAP VALVE G/ GÂCHE	(a)
211223	FERRAGEM MULTIPONTO CENTR. 1000 MULTIPOINT HARDWARE   SERRURE MULTIPOINT	2
202491	CONTRA-FECHO ANTI-LEVANTAMENTO MULTIPONTO STRIKING PLATE   GÂCHE	4
202487	CENTRADOR JT P/ O-FECHO AL MULTIPONTO T CENTERING FOR STRIKING PLATE   CENTRAGE JT POUR GÂCHE	4
212455	CONJ. FIX. CONTRA-FECHO AL MULTIP. JT MULTIPOINT HARDWARE STRIKING PLATE FIXING KIT   KIT FIXATION GÂCHE SERRURE MULTIPOINT	4
218198	CALÇO P/ MULTIPONTO SOS JT MULTIPOINT HARDWARE SHIM   CALE POUR MULTIPOINT	12
212161	CONJ. CENTRADOR P/ FERRAGEM JT CENTERING KIT FOR JT HARDWARE   KIT CENTRAGE POUR SERRURE JT	2
212371	CONJ. FIXAÇÃO JT FIXING KIT   KIT FIXATION	12
200819	PUXADOR SLIM XS - ESQUERDO LEFT HANDLE   POIGNÉE GAUCHE	1
200817	PUXADOR SLIM XS - DIREITO RIGHT HANDLE   POIGNÉE DROITE	1
212341	CONJ. TOPOS LAT. PINGADEIRA LATERAL DRIP END-CAPS KIT   KIT D'EMBOUTS LATÉRAUX POUR REJET D'EAU	1
228107	LIMITADOR ABERT. PQ SERIE CORRER OPENING LIMITER   LIMITEUR D'OUVRETURE	1
290472	PARAF. AT/PF CØ 3.9x19MM SCREW   VIS	1 + 1 un./m
290262	PARAFUSO PK INOX PH 1 1/2X10 CQ SCREW   VIS	16
218137	CALÇO REFORÇO HORIZONTAL JT * HORIZONTAL REINFORCEMENT SHIM   CALE DE RENFORCEMENT HORIZONTALE	4

\* Usar em folhas com vidros com peso superior a 80kg  
To be used in sashes which glass weight exceed 80kg | Utiliser dans des panneaux de verre d'un poids supérieur à 80 kg

(a) Conforme esquemas de drenagem (Capítulo V - Maquinações)  
According to drainage schemes (Chapter V - Machinings) | Selon les schémas de drainage (Chapitre V - Usinages)

VEDANTES   SEALS   JOINTS		
CÓDIGO CODE   CODE	DESIGNAÇÃO DESIGNATION   NOMINATION	QUANT. QUANTITY QUANTITÉ
208346	JUNTA TAPA CANAL 2116 JT JOINT   JOINT	2L + 2H
208099	JUNTA VIDRO U 1032 CX 32MM JT GLAZING GASKET   JOINT DE VITRAGE	2L + 4H
208307	PELUCIA 7x10 TRI-FIN PRETA PILE SEAL   JOINT BROSSSE	4L + 8H

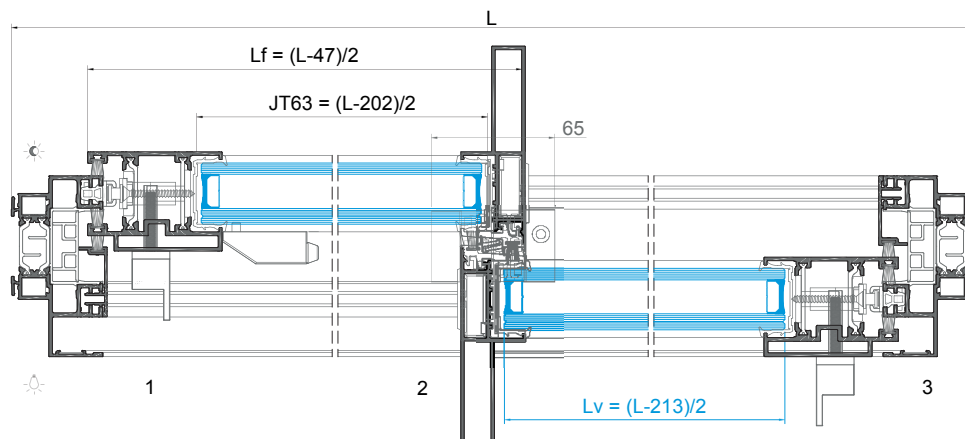
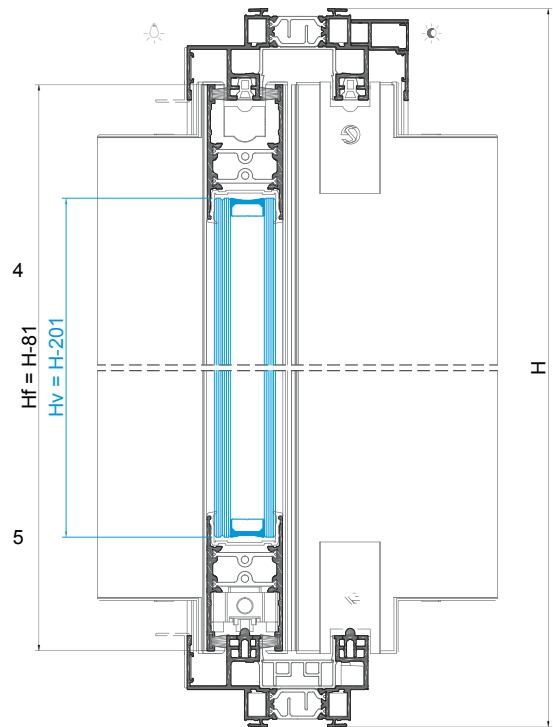

**JANELA DE CORRER 3 FOLHAS 2-RAIL- LINHA FR**  
3 SASHES 2-RAIL SLIDING WINDOW - FR LINE  
FENÊTRE COULISSANT 3 VANTAUX 2-RAIL - LIGNE FR

PERFIS   PROFILES   PROFILÉS					
CÓDIGO CODE   CODE	DESIGNAÇÃO DESIGNATION   NOMINATION	CORTE HORIZ. HORIZONTAL CUT COUPE HORIZ.	CORTE VERT. VERTICAL CUT COUPE VERTICALE	QUANT. QUANTITY QUANTITE	CORTE CUT COUPE
JT 02	ARO FIXO FIXED FRAME   CADRE DORMANT	L	H	2 + 2	
JT 54	PERFIL CENTRAL CENTRAL PROFILE   PROFILÉ CENTRAL	-	H-81	4	
JT 68	PERFIL LATERAL LATERAL PROFILE   PROFILÉ LATÉRAL	-	H-81	2	
JT 63	TRAVESSA SUP/INF UP/LW TRANSOM   TRAVERSE SUP/INF	(L-208)/3 (L-206)/3	-	4 2	
AT 30	CAPA COVER   CAPOT	L-44	-	1	
JT 83	PERFIL PINGADEIRA DRIP PROFILE   LARMIER	L-44	-	1	
JT 85	CAPA COVER   CAPOT	-	H-58	2	
JT 87	GUIA GUIDE   GUIDE	L-102 L-97	-	1 1	
208346	JUNTA CENTRAL 2196 CENTRAL JOINT   JOINT CENTRALE	-	H-81	4	
215305	PERFIL PVC U U PVC PROFILE   PROFILÉ PVC U	L-41	H-41	2 + 2	
215303	PERFIL PVC T T PVC PROFILE   PROFILÉ PVC T	(L-110)/3 (L-385)/3	H-44	2 1 + 2	

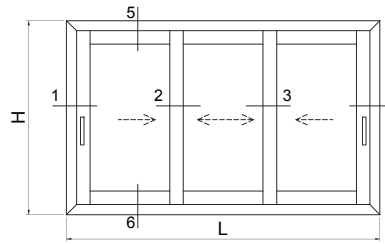

ACESSÓRIOS   ACCESSORIES   ACCESSOIRES		
CÓDIGO CODE   CODE	DESIGNAÇÃO DESIGNATION   NOMINATION	QUANT. QUANTITY QUANTITE
205129	CARRINHO JT 180KG ROLLER   ROULETTE	6
213286	CORTA-VENTO JT CENTRAL WATERPROOFING BRUSH   BROSSSE CENTRALE D'ÉTANCHÉITÉ	4
212337	CONJ. ESTANQ. CORTA-VENTO JT CENTRAL WATERPROOFING BRUSH KIT   KIT BROSSSE CENTRALE D'ÉTANCHÉITÉ	2
204164	ESQUADRO JT 12x9,5 CORNER GLEAT   ÉQUERRE	8
213014	CANTO ALINHAMENTO JT ALIGNMENT CORNER   ANGLE D'ALIGNEMENT	4
213246	CANTO CR S/SB CORNER   ANGLE	4
212199	CONJ. TOPOS LAT. JT LATERAL END-CAPS KIT   KIT D'EMBOUITS LATÉRAUX	2
212230	CONJ. TOPOS INTERIOR LAT. JT LATERAL INNER END-CAPS KIT   KIT D'EMBOUITS INTÉRIEUR LATÉRAUX	2
212201	CONJ. TAMPAS TOPOS LAT. JT LATERAL END-CAP COVERS KIT   KIT DE COUVERTURE POUR EMBOUTS LATÉRAUX	2
210288	TOPO LATERAL JT68 28MM 28MM LBS LATERAL END-CAPS KIT   KIT D'EMBOUITS LATÉRAUX JT68 28MM	4
212231	CONJ. TOPOS CENTRAIS JT CENTRAL END-CAPS KIT   KIT D'EMBOUITS CENTRAUX	4
212339	CONJ. TAMPAS TOPOS CENTRAIS JT CENTRAL END-CAP COVERS KIT   KIT DE COUVERTURE POUR EMBOUTS CENTRAUX	4
210243	TOPO CENTRAL REFORÇADO JT54 28MM 28MM CENTRAL REINFORCED END-CAPS KIT   KIT D'EMBOUITS CENTRAUX REINFORÇÉ 28MM	8
210269	GOTEIRA OCULTA C/ VALV. SV-C13 HIDE VALVE GÂCHE	(a)
211223	FERRAGEM MULTIPONTO CENTR. 1000 MULTIPOINT HARDWARE   SERRURE MULTIPONTO	2
202491	CONTRA-FECHO ANTI-LEVANTAMENTO MULTIPONTO STRIKING PLATE   GÂCHE	4
202487	CENTRADOR JT P/ C-FECHO AL MULTIPONTO FIX CENTERING FOR STRIKING PLATE   CENTRAGE JT POUR GÂCHE	4
212455	CONJ. FIX. CONTRA-FECHO AL MULTIP. JT MULTIPOINT HARDWARE STRIKING PLATE FIXING KIT   KIT FIXATION GÂCHE SERRURE MULTIPONTO	4
218198	CALÇO P/ MULTIPONTO SOS JT MULTIPOINT HARDWARE SHIM   CALE POUR MULTIPONTO	12
212161	CONJ. CENTRADOR P/ FERRAGEM JT CENTERING KIT FOR JT HARDWARE   KIT CENTRAGE POUR SERRURE JT	2
212371	CONJ. FIXAÇÃO JT FIXING KIT   KIT FIXATION	12
200819	PUXADOR SLIM XS - ESQUERDO LEFT HANDLE   POIGNÉE GAUCHE	1
200817	PUXADOR SLIM XS - DIREITO RIGHT HANDLE   POIGNÉE DROITE	1
212341	CONJ. TOPOS LAT. PINGADEIRA LATERAL DRIP END-CAPS KIT   KIT D'EMBOUITS LATÉRAUX POUR REJET D'EAU	1
290472	PARAF. AT/PF CQ Ø3.9x19MM SCREW   IVS	1 + 1 un./m
290262	PARAFUSO PK INOX PH 1 1/2X10 CQ SCREW   IVS	24
218137	CALÇO REFORÇO HORIZONTAL JT * HORIZONTAL REINFORCEMENT SHIM   COLE DE RENFORCEMENT HORIZONTALE	6

\* Usar em folhas com vidros com peso superior a 80kg  
To be used in sashes which glass weight exceed 80kg | Utiliser dans des panneaux de verre d'un poids supérieur à 80 kg  
(a) Conforme esquemas de drenagem (Capítulo V - Maquinações)  
According to drainage schemes (Chapter V - Machinings) | Selon les schémas de drainage (Chapitre V - Usinages)

VEDANTES   SEALS   JOINTS		
CÓDIGO CODE   CODE	DESIGNAÇÃO DESIGNATION   NOMINATION	QUANT. QUANTITY QUANTITE
208348	JUNTA TAPA CANAL 2116 JT JOINT   JOINT	2L + 2H
208099	JUNTA VIDRO U 1032 CX 32MM JT GLAZING GASKET   JOINT DE VITRAGE	2L + 6H
208307	PELUCIA 7x10 TRI-FIN PRETA PILE SEAL   JOINT BROSSSE	4L + 10H

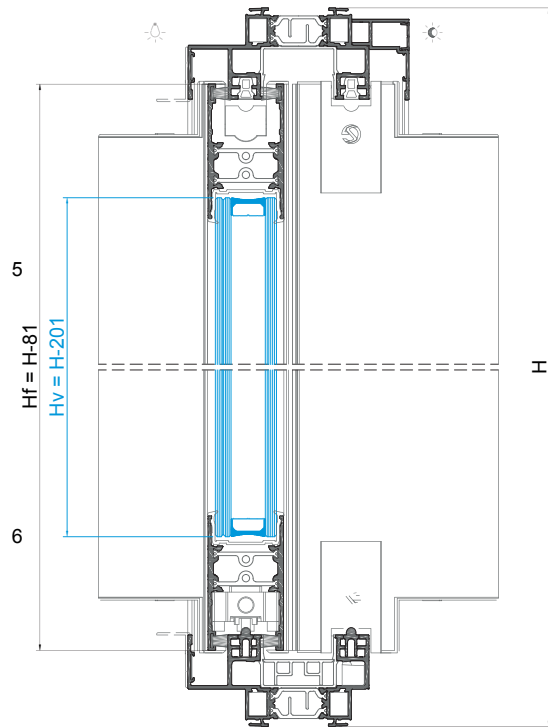

As fórmulas foram concebidas para medidas de vidros iguais.  
Nesta tipologia existem 2 larguras de folha distintas: Lf1 e Lf2.  
The formulas were designed for glasses with equal measures. In this typology there are 2 distinct sash widths: Lf1 and Lf2.  
Les formules sont conçues pour mesurer le verre. Dans cette typologie, il existe 2 largeurs de vantaux distinctes: Lf1 et Lf2.

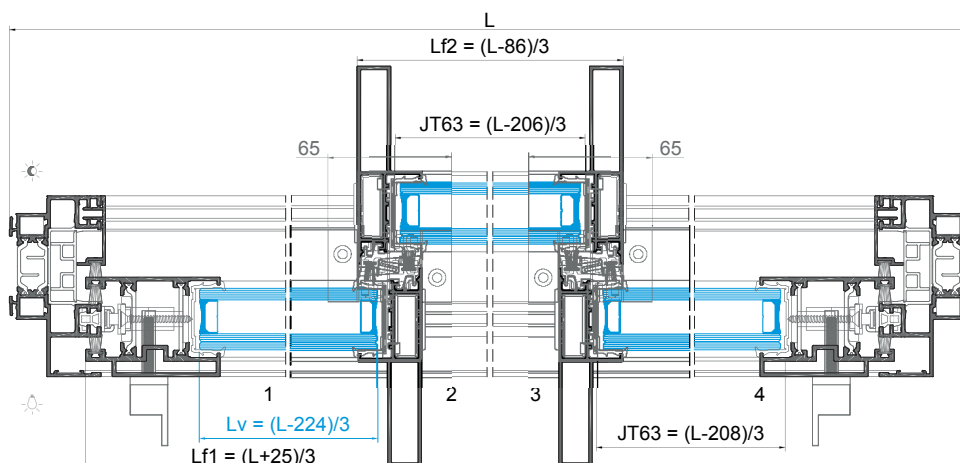



**JANELA DE CORRER 4 FOLHAS 2-RAIL COM LIGAÇÃO CENTRAL - LINHA FR**  
4 SASHES SLIDING 2-RAIL WINDOW WITH CENTRAL CONNECTION - FR LINE  
FENÊTRE COULISSANT 4 VANTAUX 2-RAIL AVEC CONNEXION CENTRALE - LIGNE FR

PERFIS   PROFILES   PROFILÉS					
CÓDIGO CODE   CODE	DESIGNAÇÃO DESIGNATION   NOMINATION	CORTE HORIZ. HORIZONTAL CUT COUPE HORIZ.	CORTE VERT. VERTICAL CUT COUPE VERTICALE	QUANT. QUANTITY QUANTITE	CORTE CUT COUPE
JT 02	ARO FIXO FIXED FRAME   CADRE DORMANT	L	H	2 + 2	
JT 54	PERFIL CENTRAL CENTRAL PROFILE   PROFILÉ CENTRAL	-	H-81	4	
JT 68	PERFIL LATERAL LATERAL PROFILE   PROFILÉ LATÉRAL	-	H-81	4	
JT 63	TRAVESSA SUP/INF UP/LW TRANSOM   TRAVERSE SUP/INF	(L-330)/4	-	8	
JT 71	PERFIL LIGAÇÃO CENTRAL CONNECTION PROFILE   PROFILÉ DE LIASON	-	H-149	1	
AT 30	CAPA COVER   CAPOT	L-44	-	1	
JT 83	PERFIL PINGADEIRA DRIP PROFILE   L'ARMIER	L-44	-	1	
JT 85	CAPA COVER   CAPOT	-	H-58	2	
JT 87	GUIA GUIDE   GUIDE	L-102 L-97	-	1	
208346	JUNTA CENTRAL 2196 CENTRAL JOINT CENTRALE	-	H-81	4	
215305	PERFIL PVC U U PVC PROFILE   PROFILÉ PVC U	L-41	H-41	2 + 2	
215303	PERFIL PVC T T PVC PROFILE   PROFILÉ PVC T	(L-198)/4 (L-335)/4	H-44	2 + 2	

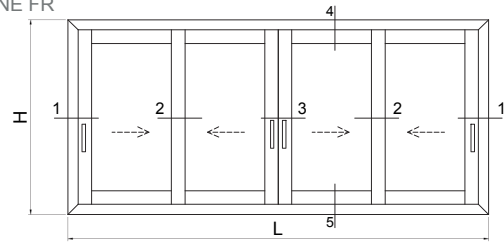

ACESSÓRIOS   ACCESSORIES   ACCESSOIRES		
CÓDIGO CODE   CODE	DESIGNAÇÃO DESIGNATION   NOMINATION	QUANT. QUANTITY QUANTITE
205129	CARRINHO JT 180KG ROLLER   ROULETTE	8
213286	CORTA-VENTO JT CENTRAL WATERPROOFING BRUSH   BRASSE CENTRALE D'ÉTANCHÉITÉ	6
212337	CONJ. ESTANQ. CORTA-VENTO JT CENTRAL WATERPROOFING BRUSH KIT   KIT BRASSE CENTRALE D'ÉTANCHÉITÉ	3
204164	ESQUADRO JT 12x9.5 CORNER CLEAT   EQUERRE	8
213014	CANTO ALINHAMENTO JT ALIGNMENT CORNER   ANGLE D'ALIGNEMENT	4
213246	CANTO CR S/SB CORNER   ANGLE	4
212199	CONJ. TOPOS LAT. JT LATERAL END-CAPS KIT   KIT D'EMBOUS LATERAUX	4
212230	CONJ. TOPOS INTERIOR LAT. JT LATERAL INNER END-CAPS KIT   KIT D'EMBOUS INTÉRIEUR LATÉRAL	3
212201	CONJ. TAMPAS TOPOS LAT. JT LATERAL END-CAP COVERS KIT   KIT DE COUVERTURE POUR EMBOUTS LATERAUX	3
210288	TOPO LATERAL JT68 28MM 28MM JT68 LATERAL END-CAPS KIT   KIT D'EMBOUS LATERAUX JT68 28MM	8
212231	CONJ. TOPOS CENTRAIS JT CENTRAL END-CAPS KIT   KIT D'EMBOUS CENTRAUX	4
212339	CONJ. TAMPAS TOPOS CENTRAIS JT CENTRAL END-CAP COVERS KIT   KIT DE COUVERTURE POUR EMBOUTS CENTRAUX	4
210243	TOPO CENTRAL REFORÇADO JT54 28MM 28MM CENTRAL REINFORCED END-CAPS KIT   KIT D'EMBOUS CENTRAUX RENFORCÉ 28MM	8
212104	CONJ. TOPOS LIG. 2 FOLHAS JT 2 SASHES CONNECTING END-CAPS KIT   KIT D'EMBOUS CONNEXION 2 VANTAUX	1
210269	GOITEIRA OCULTA C/ VALV. SV-C13 FLAP VALVE C/ FLAPE A VALVE CACHE	(a)
211223	FERRAGEM MULTIPONTO CENTR. 1000 MULTIPOINT HARDWARE   SERRURE MULTIPONTO	3
202491	CONTRA-FECHO ANTI-LEVANTAMENTO MULTIPONTO STRIKING PLATE   GÂCHE	4
202487	CENTRADOR JT P/ C-FECHO AL MULTIPONTO JT CENTERING FOR STRIKING PLATE   CENTRAGE JT POUR GÂCHE	4
212455	CONJ. FIX. CONTRA-FECHO AL MULTIP. JT MULTIPOINT HARDWARE STRIKING PLATE FIXING KIT   KIT FIXATION GÂCHE SERRURE MULTIPONTO	4
212458	CONJ. FIX. CONTRA-FECHO MULTIP. 2F/90° JT MULTIPOINT HARDWARE STRIKING PLATE FIXING KIT   KIT FIXATION GÂCHE SERRURE MULTIP.	2
218198	CALÇO P/ MULTIPONTO SOS JT MULTIPOINT HARDWARE SHIM   CALE POUR MULTIPONTO	18
218154	CALÇO P/ C-FECHO PERF. LIG CONNECTING PROFILE STRIKING PLATE SHIM   CALE POUR GÂCHE PROFILÉ DE LIASON	2
212161	CONJ. CENTRADOR P/ FERRAGEM JT CENTERING KIT FOR JT HARDWARE   KIT CENTRAGE POUR SERRURE JT	2
212162	CONJ. CENTRADOR P/ FERRAGEM JT PERFIL LIG. CENTERING KIT FOR JT HARDWARE   KIT CENTRAGE POUR SERRURE JT	1
212371	CONJ. FIXAÇÃO JT FIXING KIT   KIT FIXATION	18
212017	CONJ. FIX. FERRAGEM MULTIP. MULTIPOINT HARDWARE FIXING KIT   KIT FIXATION POUR SERRURE MULTIPONTO	1 + 1 un./m (min. 4)
200819	PUXADOR SLIM XS - ESQUERDO LEFT HANDLE   POIGNÉE GAUCHE	1
200817	PUXADOR SLIM XS - DIREITO RIGHT HANDLE   POIGNÉE DROITE	2
200057	PUXADOR FOLHA PASSIVA SLIM XS PASSIVE SASH HANDLE   POIGNÉE VENTAIL PASSIVE	1
212341	CONJ. TOPOS LAT. PINGADEIRA LATERAL DRIP END-CAPS KIT   KIT D'EMBOUS LATÉRAUX POUR REJET D'EAU	1
228107	LIMITADOR ABERT. PQ SERIE CORRER OPENING LIMITER   LIMITEUR D'OUVERTURE	2
290472	PARAF. AT/PF CQ Ø3.9x19MM SCREW   VIS	1 + 1 un./m
290262	PARAFUSO PK INOX PH 1 1/2X10 CQ SCREW   VIS	32
218137	CALÇO REFORÇO HORIZONTAL JT * HORIZONTAL REINFORCEMENT SHIM   CALE DE RENFORCEMENT HORIZONTALE	8

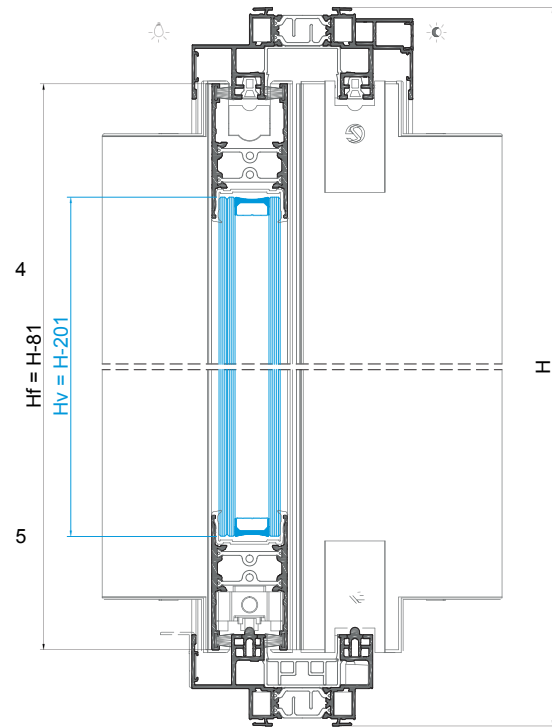

VEDANTES   SEALS   JOINTS		
CÓDIGO CODE   CODE	DESIGNAÇÃO DESIGNATION   NOMINATION	QUANT. QUANTITY QUANTITE
208348	JUNTA TAPA CANAL 2116 JT JOINT JOINT	2L + 2H
208099	JUNTA VIDRO U 1032 CX 32MM JT GLAZING GASKET   JOINT DE VITRAGE	2L + 8H
208307	PELUCIA 7x10 TRI-FIN PRETA PILE SEAL   JOINT BRASSE	4L + 14H
208479	JUNTA TAPA CANAL PERFIL LIG. 2117 JT JOINT JOINT	H

\* Usar em folhas com vidros com peso superior a 80kg  
To be used in sashes which glass weight exceed 80kg | Utiliser dans des panneaux de verre d'un poids supérieur à 80 kg  
(a) Conforme esquemas de drenagem (Capítulo V - Maquinações)  
According to drainage schemes (Chapter V - Machinings) | Selon les schémas de drainage (Chapitre V - Usinages)

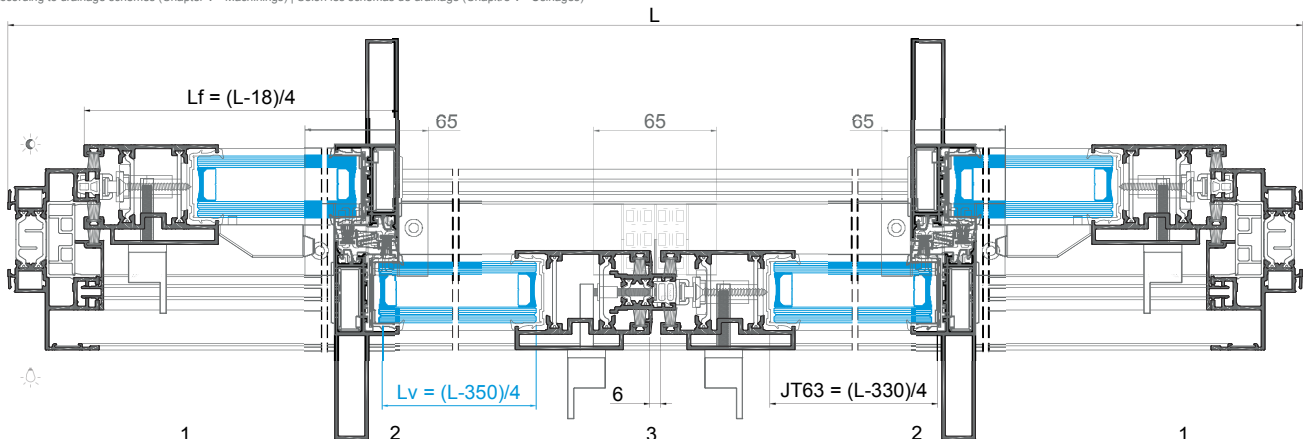

**JANELA DE CORRER 4 FOLHAS 2-RAIL CANTO 90° - LINHA FR**  
4 SASHES 2-RAIL SLIDING WINDOW IN 90° CORNER - FR LINE  
FENÊTRE COULISSANT 4 VANTAUX 2-RAIL À ANGLE 90° - LIGNE FR

PERFIS   PROFILES   PROFILÉS					
CÓDIGO CODE   CODE	DESIGNAÇÃO DESIGNATION   NOMINATION	CORTE HORIZ. HORIZONTAL CUT COUPE HORIZ.	CORTE VERT. VERTICAL CUT COUPE VERTICALE	QUANT. QUANTITY QUANTITÉ	CORTE CUT COUPE
JT 02	ARO FIXO FIXED FRAME   CADRE DORMANT	L1 L2	H	2 + 2	
JT 54	PERFIL CENTRAL CENTRAL PROFILE   PROFILÉ CENTRAL	-	H-81	4	
JT 67	PERFIL LATERAL LATERAL PROFILE   PROFILÉ LATÉRAL	-	H-81	2	
JT 62	PERFIL LATERAL CANTO 90° 90° CORNER LAT. PR.   PR. LAT. D'ANGLE À 90°	-	H-81	2	
JT 63	TRAVESSA SUP/INF UP/LW TRANSOM   TRAVERSE SUP/INF	(L1-243)/2 (L2-256)/2	-	4 4	
JT 72	PERFIL LIGAÇÃO CANTO 90° CONNECTION PROFILE   PROFILÉ DE LIAISON	-	H-149	1	
AT 30	CAPA CAPOT	L1-1 L2-1	-	1	
JT 83	PERFIL PINGADEIRA DRIP PROFILE   LARMIER	L1-1 L2-1	-	1	
JT 85	CAPA COVER   CAPOT	-	H-58	2	
JT 87	GUIA GUIDE   GUIDE	L1-43 L1-112 L2-43 L2-112	-	1 1 1 1	
208346	JUNTA CENTRAL 2196 CENTRAL JOINT   JOINT CENTRALE	-	H-81	4	
215305	PERFIL PVC U U PVC PROFILE   PROFILÉ PVC U	L1-38 L2-38	H-41	2 + 2	
215303	PERFIL PVC T T PVC PROFILE   PROFILÉ PVC T	(L1-122)/2 (L1-230)/2 (L2-134)/2 (L2-218)/2	H-44	1 1 1 1	

ACESSÓRIOS   ACCESSORIES   ACCESSOIRES		
CÓDIGO CODE   CODE	DESIGNAÇÃO DESIGNATION   NOMINATION	QUANT. QUANTITY QUANTITÉ
205129	CARRINHO JT 180KG ROLLER   ROULETTE	8
213286	CORTA-VENTO JT CENTRAL WATERPROOFING BRUSH   BROSSSE CENTRALE D'ÉTANCHÉITÉ	4
213287	CORTA-VENTO CANTO 90° JT 90° CORNER WATERPROOFING BRUSH   BROSSSE D'ÉTANCHÉITÉ ANGLE 90°	2
212337	CONJ. ESTANQ. CORTA-VENTO JT CENTRAL WATERPROOFING BRUSH KIT   KIT BROSSSE CENTRALE D'ÉTANCHÉITÉ	4
204164	ESQUADRO JT 12x9.5 CORNER CLEAT   ÉQUERRE	8
213014	CANTO ALINHAMENTO JT ALIGNMENT CORNER   ANGLE D'ALIGNEMENT	4
212243	CONJ. UNIÃO CANTO 90° JT 90° CORNER UNION KIT   KIT UNION ANGLE 90°	1
204389	ESQUADRO INOX CANTO 90° 90° STAINLESS STEEL CORNER   ANGLE EN ACIER INOXYDABLE 90°	2
213246	CANTO CR S/SB CORNER   ANGLE	4
212199	CONJ. TOPOS LAT. JT LATERAL END-CAPS KIT   KIT D'EMBOUTS LATÉRAUX	4
212230	CONJ. TOPOS INTERIOR LAT. JT LATERAL INNER END-CAPS KIT   KIT D'EMBOUTS INTÉRIEUR LATÉRAUX	3
212201	CONJ. TAMPAS TOPOS LAT. JT LATERAL END-CAP COVERS KIT   KIT DE COUVERTURE POUR EMBOUTS LATÉRAUX	3
212231	CONJ. TOPOS CENTRAIS JT CENTRAL END-CAPS KIT   KIT D'EMBOUTS CENTRAUX	4
212339	CONJ. TAMPAS TOPOS CENTRAIS JT CENTRAL END-CAP COVERS KIT   KIT DE COUVERTURE POUR EMBOUTS CENTRAUX	4
210243	TOPO CENTRAL REFORÇADO JT54 28MM 28MM CENTRAL REINFORCED END-CAPS KIT   KIT D'EMBOUTS CENTRAUX RENFORCÉ 28MM	8
212109	CONJ. TOPOS CANTO 90° JT 90° CORNER END-CAPS KIT   KIT D'EMBOUTS POUR ANGLE 90°	1
210269	GOTEIRA OCULTA C/ VALV. SV-C13 FLAP VALVE   CLAPPE À VALVET GÂCHE	(a)
211223	FERRAGEM MULTIPONTO CENTR. 1000 MULTIPOINT HARDWARE   SERRURE MULTIPONT	3
202491	CONTRA-FECHO ANTI-LEVANTAMENTO MULTIPONTO STRIKING PLATE   GÂCHE	6
202487	CENTRADOR JT P/ C-FECHO AL MULTIPONTO JT CENTERING FOR STRIKING PLATE   CENTRAGE JT POUR GÂCHE	4
212455	CONJ. FIX. CONTRA-FECHO AL MULTIP. JT MULTIPOINT HARDWARE STRIKING PLATE FIXING KIT   KIT FIXATION GÂCHE SERRURE MULTIPONT	4
212458	CONJ. FIX. CONTRA-FECHO MULTIP. 2F/90° JT MULTIPOINT HARDWARE STRIKING PLATE FIXING KIT   KIT FIXATION GÂCHE SERRURE MULTIP.	2
218154	CALÇO P/ C-FECHO PERF. LIG CONNECTING PROFILE STRIKING PLATE SHIM   CALE POUR GÂCHE PROFILÉ DE LIAISON	2
218198	CALÇO P/ MULTIPONTO SOS JT MULTIPOINT HARDWARE SHIM   CALE POUR MULTIPONT	18
212161	CONJ. CENTRADOR P/ FERRAGEM JT CENTERING KIT FOR JT HARDWARE   KIT CENTRAGE POUR SERRURE JT	2
212162	CONJ. CENTRADOR P/ FERRAGEM JT PERFIL LIG. CENTERING KIT FOR JT HARDWARE   KIT CENTRAGE POUR SERRURE JT	1
212371	CONJ. FIXAÇÃO JT FIXING KIT   KIT FIXATION	18
212079	CONJ. FIX. FERRAGEM MULTIP. JT72 MULTIPOINT FIXING KIT   KIT FIXATION SERRURE MULTIPONT	1 + 1 un./m (min. 4)
200819	PUXADOR SLIM XS - ESQUERDO LEFT HANDLE   POIGNÉE GAUCHE	1
200817	PUXADOR SLIM XS - DIREITO RIGHT HANDLE   POIGNÉE DROITE	2
212341	CONJ. TOPOS LAT. PINGADEIRA LATERAL DRIP END-CAPS KIT   KIT D'EMBOUTS LATÉRAUX POUR REJET D'EAU	1
228107	LIMITADOR ABERT. PQ SERIE CORRER OPENING LIMITER   LIMITEUR D'OUVERTURE	2
290472	PARAF. AT/PF CQ Ø3.9x19MM SCREW   VIS	1 + 1 un./m
290262	PARAFUSO PK INOX PH 1 1/2x10 CQ SCREW   VIS	32
218137	CALÇO REFORÇO HORIZONTAL JT * HORIZONTAL REINFORCEMENT SHIM   CALE DE RENFORCEMENT HORIZONTALE	8

\* Usar em folhas com vidros com peso superior a 80kg  
To be used in sashes which glass weight exceed 80kg | Utiliser dans des panneaux de verre d'un poids supérieur à 80 kg  
(a) Conforme esquemas de drenagem (Capítulo V - Maquinações)  
According to drainage schemes (Chapter V - Machinings) | Selon les schémas de drainage (Chapitre V - Usinages)

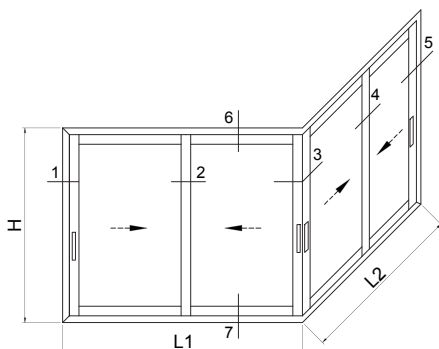

VEDANTES   SEALS   JOINTS		
CÓDIGO CODE   CODE	DESIGNAÇÃO DESIGNATION   NOMINATION	QUANT. QUANTITY QUANTITÉ
208348	JUNTA TAPA CANAL 2116 JT JOINT   JOINT	2L1 2L2 + 2H
208099	JUNTA VIDRO U 1032 CX 32MM JT GLAZING GASKET   JOINT DE VITRAGE	2L1 + 8H 2L2
208307	PELUCIA 7x10 TRI-FIN PRETA FILE SEAL   JOINT BRUSSE	4L1 + 15H 4L2
208479	JUNTA TAPA CANAL PERFIL LIG. 2117 JT JOINT   JOINT	H
208435	JUNTA VD 2415 JOINT   JOINT	H

As fórmulas foram concebidas para medidas de vidros iguais. Nesta tipologia existem 4 larguras de folha distintas: Lf1, Lf2, Lf3 e Lf4.  
The formulas were designed for glasses with equal measures. In this typology there are 4 distinct sash widths: Lf1, Lf2, Lf3 and Lf4.  
Les formules sont conçues pour mesurer le verre. Dans cette typologie, il existe 4 largeurs de vantaux distinctes: Lf1, Lf2, Lf3 et Lf4.

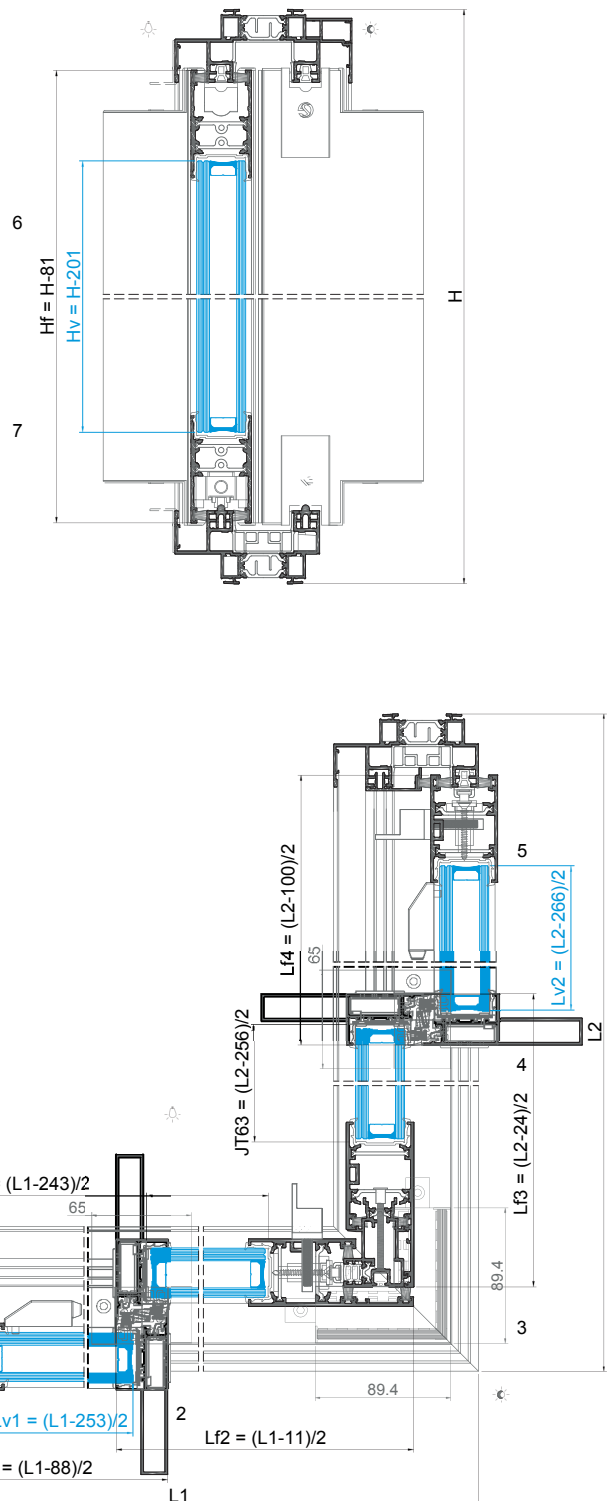



**JANELA DE CORRER 3 FOLHAS 3-RAIL - LINHA FR**  
3 SASHES 3-RAIL SLIDING WINDOW - FR LINE  
FENÊTRE COULISSANT 3 VANTAUX 3-RAIL - LIGNE FR

PERFIS   PROFILES   PROFILÉS					
CÓDIGO CODE   CODE	DESIGNAÇÃO DESIGNATION   NOMINATION	CORTE HORIZ. HORIZONTAL CUT COUPE HORIZ.	CORTE VERT. VERTICAL CUT COUPE VERTICALE	QUANT. QUANTITY QUANTITE	CORTE CUT COUPE
JT 03	ARO FIXO FIXED FRAME   CADRE DORMANT	L	H	2 + 2	
JT 54	PERFIL CENTRAL CENTRAL PROFILE   PROFILÉ CENTRAL	-	H-81	4	
JT 68	PERFIL LATERAL LATERAL PROFILE   PROFILÉ LATÉRAL	-	H-81	2	
JT 63	TRAVESSA SUP/INF UP/LW TRANSOM   TRAVERSE SUP/INF	(L-209)/3 (L-207)/3	-	4	
AT 30	CAPA COVER   CAPOT	L-44	-	1	
JT 83	PERFIL PINGADEIRA DRIP PROFILE   LARMIER	L-44	-	1	
JT 88	CAPA COVER   CAPOT	-	H-58	2	
JT 87	GUIA GUIDE   GUIDE	L-100 L-97	-	2 1	
208346	JUNTA CENTRAL 2196 CENTRAL JOINT   JOINT CENTRALE	-	H-81	4	
215305	PERFIL PVC U PVC PROFILE   PROFILÉ PVC U	L-41	H-41	4 + 4	
215303	PERFIL PVC T PVC PROFILE   PROFILÉ PVC T	(L-109)/3 (2L-298)/3	H-44	2 + 4	

ACESSÓRIOS   ACCESSORIES   ACCESSOIRES		
CÓDIGO CODE   CODE	DESIGNAÇÃO DESIGNATION   NOMINATION	QUANT. QUANTITY QUANTITE
205129	CARRINHO JT 180KG ROLLER   ROULETTE	6
213286	CORTA-VENTO JT CENTRAL WATERPROOFING BRUSH   BROSSSE CENTRALE D'ÉTANCHÉITÉ	4
212337	CONJ. ESTANQ. CORTA-VENTO JT CENTRAL WATERPROOFING BRUSH KIT   KIT BROSSSE CENTRALE D'ÉTANCHÉITÉ	2
204164	ESQUADRO JT 12x9.5 CORNER CLEAT   ÉQUERRE	12
213014	CANTO ALINHAMENTO JT ALIGNMENT CORNER   ANGLE D'ALIGNEMENT	4
213246	CANTO CR S/SB CORNER   ANGLE	4
212199	CONJ. TOPOS LAT. JT LATERAL END-CAPS KIT   KIT D'EMBOUITS LATÉRAUX	2
212230	CONJ. TOPOS INTERIOR LAT. JT LATERAL INNER END-CAPS KIT   KIT D'EMBOUITS INTÉRIEUR LATÉRAUX	2
212201	CONJ. TAMPAS TOPOS LAT. JT LATERAL END-CAP COVERS KIT   KIT DE COUVERTURE POUR EMBOUTS LATÉRAUX	2
210288	TOPO LATERAL JT68 28MM 28MM LATERAL END-CAPS KIT   KIT D'EMBOUITS LATÉRAUX JT68 28MM	4
212231	CONJ. TOPOS CENTRAIS JT CENTRAL END-CAPS KIT   KIT D'EMBOUITS CENTRAUX	4
212339	CONJ. TAMPAS TOPOS CENTRAIS JT CENTRAL END-CAP COVERS KIT   KIT DE COUVERTURE POUR EMBOUTS CENTRAUX	4
210243	TOPO CENTRAL REFORÇADO JT54 28MM 28MM CENTRAL REINFORCED END-CAPS KIT   KIT D'EMBOUITS CENTRAUX RENFORCÉ 28MM	8
210269	GOTEIRA OCULTA C/ VALV. SV-C13 FLAP VALVE   CLAPE À VOILET CACHE	(a)
211223	FERRAGEM MULTIPONTO CENTR. 1000 MULTIPOINT HARDWARE   SERRURE MULTIPOINT	2
202491	CONTRA-FECHO ANTI-LEVANTAMENTO MULTIPONTO STRIKING PLATE   GÂCHE	4
202487	CENTRADOR JT P/ C-FECHO AL MULTIPONTO JT CENTERING FOR STRIKING PLATE   CENTRAGE JT POUR GÂCHE	4
212455	CONJ. FIX. CONTRA-FECHO AL MULTIP. JT MULTIPOINT HARDWARE STRIKING PLATE FIXING KIT   KIT FIXATION GÂCHE SERRURE MULTIPOINT	4
218198	CALÇO P/ MULTIPONTO SOS JT MULTIPOINT HARDWARE SHIM   CALE POUR MULTIPOINT	12
212161	CONJ. CENTRADOR P/ FERRAGEM JT CENTERING KIT FOR JT HARDWARE   KIT CENTRAGE POUR SERRURE JT	2
212371	CONJ. FIXAÇÃO JT FIXING KIT   KIT FIXATION	12
200819	PUXADOR SLIM XS - ESQUERDO LEFT HANDLE   POIGNÉE GAUCHE	1
200817	PUXADOR SLIM XS - DIREITO RIGHT HANDLE   POIGNÉE DROITE	1
212341	CONJ. TOPOS LAT. PINGADEIRA LATERAL DRIP END-CAPS KIT   KIT D'EMBOUITS LATÉRAUX POUR REJET D'EAU	1
228107	LIMITADOR ABERT. PQ SERIE CORRER OPENING LIMITER   LIMITEUR D'OUVERTURE	1
290472	PARAF. AT/PF CQ Ø3.9x19MM SCREW   VIS	1 + 1 un./m
290262	PARAFUSO PK INOX PH 1 1/2X10 CQ SCREW   VIS	24
218137	CALÇO REFORÇO HORIZONTAL JT * HORIZONTAL REINFORCEMENT SHIM   CALE DE RENFORCEMENT HORIZONTALE	6

\* Usar em folhas com vidros com peso superior a 80kg  
To be used in sashes which glass weight exceed 80kg | Utiliser dans des panneaux de verre d'un poids supérieur à 80 kg  
(a) Conforme esquemas de drenagem (Capítulo V - Maquinações)  
According to drainage schemes (Chapter V - Machinings) | Selon les schémas de drainage (Chapitre V - Usinages)

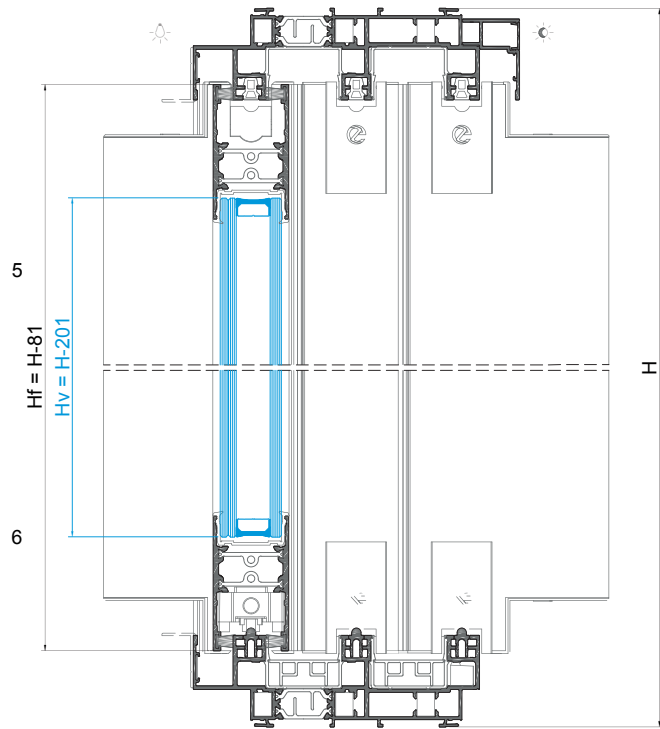
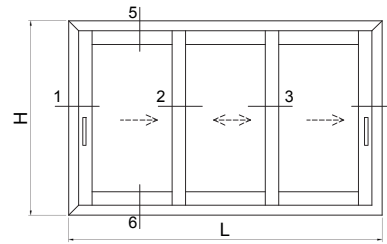

VEDANTES   SEALS   JOINTS		
CÓDIGO CODE   CODE	DESIGNAÇÃO DESIGNATION   NOMINATION	QUANT. QUANTITY QUANTITE
208348	JUNTA TAPA CANAL 2116 JT JOINT JOINT	3L + 2H
208099	JUNTA VIDRO U 1032 CX 32MM JT GLAZING GASKET   JOINT DE VITRAGE	2L + 6H
208307	PELUCIA 7x10 TRI-FIN PRETA PILE SEAL   JOINT BROSSSE	4L + 10H

As fórmulas foram concebidas para medidas de vidros iguais.  
Nesta tipologia existem 2 larguras de folha distintas: Lf1 e Lf2.  
The formulas were designed for glasses with equal measures. In  
this tipologia there are 2 distinct sash widths: Lf1 and Lf2.  
Les formules sont conçues pour mesurer le verre. Dans cette  
tipologie, il existe 2 largeurs de vantaux distinctes: Lf1 et Lf2.

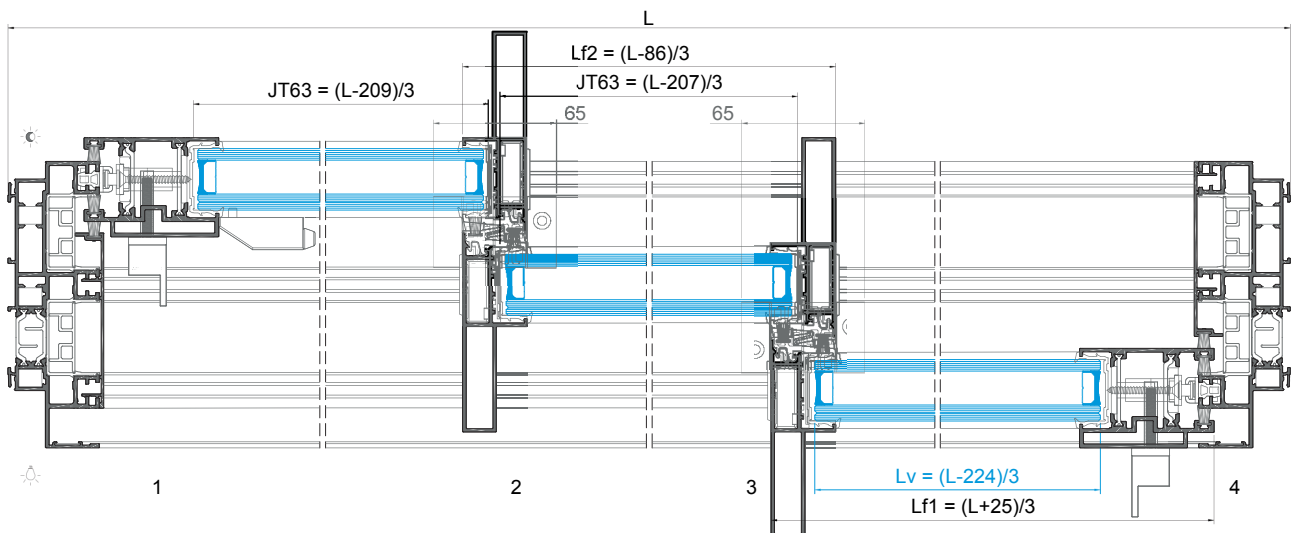

**JANELA DE CORRER 1 FOLHA DE EMBUTIR 2-RAIL - LINHA FR**  
1 SASH POCKET 2-RAIL SLIDING WINDOW - FR LINE  
FENÊTRE COULISSANT 1 VANTAIL 2-RAIL À GALANDAGE - LIGNE FR

PERFIS   PROFILÉS   PROFILÉS					
CÓDIGO CODE / CODE	DESIGNAÇÃO DESIGNATION / NOMINATION	CORTE HORIZ. HORIZONTAL CUT COUPE HORIZ.	CORTE VERT. VERTICAL CUT COUPE VERTICALE	QUANT. QUANTITY QUANTITE	CORTE CUT COUPE
JT 02	ARO FIXO FIXED FRAME   CADRE DORMANT	2L-24	H	2 + 2	
JT 51	PERFIL CENTRAL CENTRAL PROFILE   PROFILÉ CENTRAL	-	H-81	1	
JT 67	PERFIL LATERAL LATERAL PROFILE   PROFILÉ LATÉRAL	-	H-81	1	
JT 63	TRAVESSA SUP/INF UP/DOWN TRANSOM   TRAVERSE SUP/INF	L-84	-	2	
JT 85	CAPA COVER   CAPOT	L-51	H-58	2 + 1	
JT 87	GUIA GUIDE   GUIDE	2L-121	-	1	
JT 93	PERFIL MONTANTE MULION PROFILE   PROFILÉ DE MENEAU	-	H-106	1	
SO 46	PERFIL REMATE FINISHING PROFILE   PROFILÉ DE FINITION	-	H-97	1	
SO 47	PERFIL REMATE FINISHING PROFILE   PROFILÉ DE FINITION	-	H-97	1	
SO 48	PERFIL REMATE FINISHING PROFILE   PROFILÉ DE FINITION	L+86	H+3	2 + 1	
KE 71	PERFIL REMATE FINISHING PROFILE   PROFILÉ DE FINITION	L-14	-	1	
KE 90	PERFIL REMATE FINISHING PROFILE   PROFILÉ DE FINITION	2L+26 L+1	H+50	1 + 2	
KP 32	TUBO TUBE   TUBE	Variável   Variable   Variable			
208346	JUNTA CENTRAL 2196 CENTRAL JOINT   JOINT CENTRALE	-	H-106 H-81	1 1	
215305	PERFIL PVC U U PVC PROFILE   PROFILÉ PVC U	2L-64	H-41	2 + 2	
215303	PERFIL PVC T T PVC PROFILE   PROFILÉ PVC T	L-49 L-95	H-44	1 + 1	

VEDANTES   SEALS   JOINTS		
CÓDIGO CODE / CODE	DESIGNAÇÃO DESIGNATION / NOMINATION	QUANT. QUANTITY QUANTITE
208348	JUNTA TAPA CANAL 2116 JT JOINT   JOINT	2L + 3H
208099	JUNTA VIDRO U 1032 CX 32MM JT GLASS GASKET   JOINT DE VITRAGE	2L + 2H
208307	PELUCIA 7x10 TRI-FIN PRETA PILE SEAL   JOINT BROSSE	6L + 5H
208466	PELUCIA 7x12 STOP-FIN PRETA PILE SEAL   JOINT BROSSE	H

ACESSÓRIOS   ACCESSORIES   ACCESSOIRES		
CÓDIGO CODE / CODE	DESIGNAÇÃO DESIGNATION / NOMINATION	QUANT. QUANTITY QUANTITE
205129	CARRINHO JT 180KG ROLLER   ROULETTE	2
213286	CORTA-VENTO JT CENTRAL WATERPROOFING BRUSH   BROSSE CENTRALE D'ÉTANCHÉITÉ	2
212337	CONJ. ESTANQ. CORTA-VENTO JT CENTRAL WATERPROOFING BRUSH KIT   KIT BROSSE CENTRALE D'ÉTANCHÉITÉ	1
204164	ESQUADRO JT 12x9.5 CORNER GLASS   LEUVERRE	8
213014	CANTO ALINHAMENTO JT ALIGNMENT CORNER   ANGLE D'ALIGNEMENT	4
213246	CANTO CR S/SB CORNER   ANGLE	7
212199	CONJ. TOPOS LAT. JT LATERAL END-CAPS KIT   KIT D'EMBOUTS LATÉRAUX	1
212230	CONJ. TOPOS INTERIOR LAT. JT LATERAL INNER END-CAPS KIT   KIT D'EMBOUTS INTÉRIEUR LATÉRAUX	1
212201	CONJ. TAMPAS TOPOS LAT. JT LATERAL END-CAP COVERS KIT   KIT DE COUVERTURE POUR EMBOUTS LATÉRAUX	1
212231	CONJ. TOPOS CENTRAIS JT CENTRAL END-CAPS KIT   KIT D'EMBOUTS CENTRAUX	1
212339	CONJ. TAMPAS TOPOS CENTRAIS JT CENTRAL END-CAP COVERS KIT   KIT DE COUVERTURE POUR EMBOUTS CENTRAUX	1
210269	GOTEIRA OCULTA C/ VALV. SV-C13 FLAP VALVE   CLAPE À VOLET CACHÉ	(a)
211223	FERRAGEM MULTIPONTO CENTR. 1000 MULTIPOINT HARDWARE   SERRURE MULTIPONTO	1
202491	CONTRA-FECHO ANTI-LEVANTAMENTO MULTIPONTO MULTIPOINT HARDWARE   SERRURE MULTIPONTO	2
202487	CENTRADOR JT P/ C-FECHO AL MULTIPONTO JT CENTERING FOR STRIKING PLATE   CENTRAGE JT POUR GÂCHE	2
212455	CONJ. FIX. CONTRA-FECHO AL MULTIP. JT MULTIPOINT HARDWARE STRIKING PLATE FIXING KIT   KIT FIXATION GÂCHE SERRURE MULTIPONTO	2
218198	CALÇO P/ MULTIPONTO SÓS JT MULTIPOINT HARDWARE SHIM   CALE DE REINFORCEMENT MULTIPONTO	6
212161	CONJ. CENTRADOR P/ FERRAGEM JT CENTERING KIT FOR JT HARDWARE   KIT CENTRAGE POUR SERRURE JT	1
212371	CONJ. FIXAÇÃO JT FIXING KIT   KIT FIXATION	6
200819	PUXADOR SLIM XS - ESQUERDO LEFT HANDLE   POIGNÉE GAUCHE	1
212085	CONJ. TOPOS JT93 JT93 END-CAPS KIT   KIT D'EMBOUTS JT93	1
212221	CONJ. TAPA TOPOS KE71 KE71 END-CAPS KIT   KIT D'EMBOUTS KE71	1
212227	CONJ. JUNTAS ADES. P/ TOPOS PERFIL SOL. KE71 KE71 ADHESIVE JOINTS KIT   KIT DE JOINTS ADHÉSIFS KE71	1
212223	CONJ. TOPOS INFERIORES RENOVATIO RENOVATIO END-CAPS KIT   KIT D'EMBOUTS INFÉRIEUR RENOVATIO	1
290472	PARAF. AT/PF CQ Ø3.9x19MM SCREW   VIS	1 + 1 un./m
290262	PARAFUSO PK INOX PH 1 1/2X10 CQ SCREW   VIS	8
218137	CALÇO REFORÇO HORIZONTAL JT * HORIZONTAL REINFORCEMENT SHIM   CALE DE REINFORCEMENT HORIZONTALE	2

\* Usar em folhas com vidros com peso superior a 80kg  
To be used in sashes with glass weight exceed 80kg | Utiliser dans des panneaux de verre d'un poids supérieur à 80 kg  
(a) Conforme esquemas de drenagem (Capítulo V - Maquinações)  
According to drainage schemes (Chapter V - Machinings) | Selon les schémas de drainage (Chapitre V - Usinages)

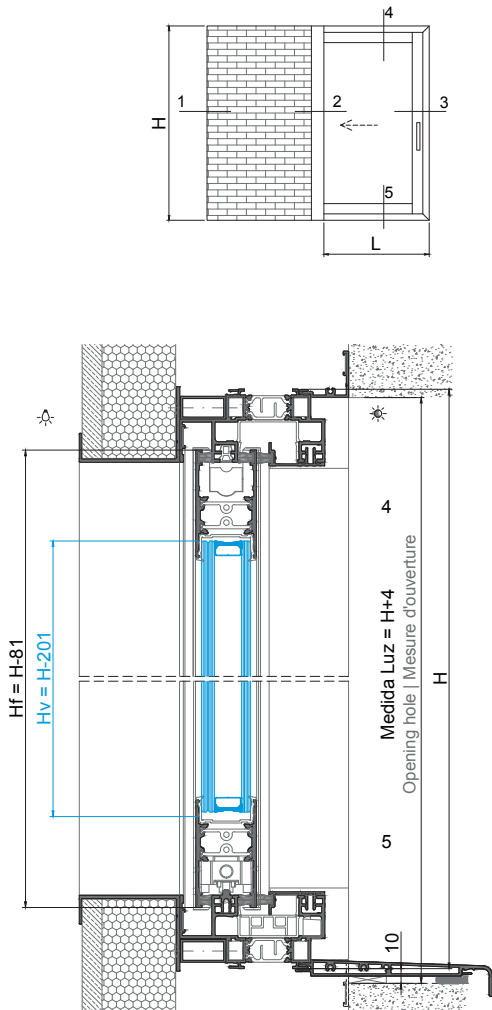

Fechado | Closed | Fermé

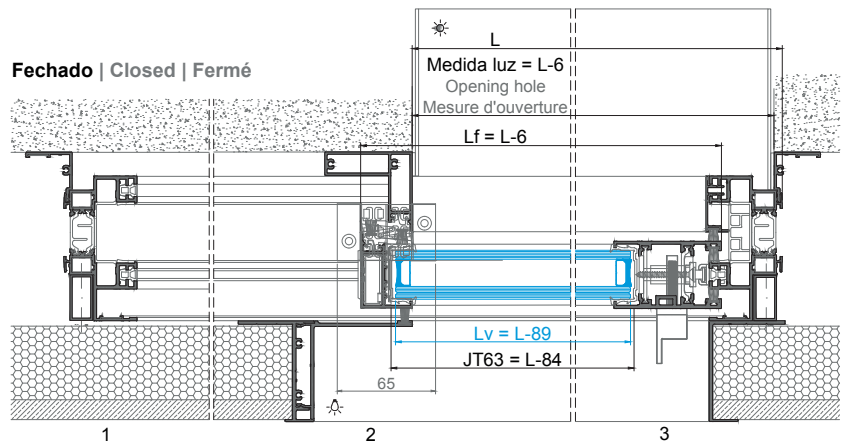

Aberto | Open | Ouvert

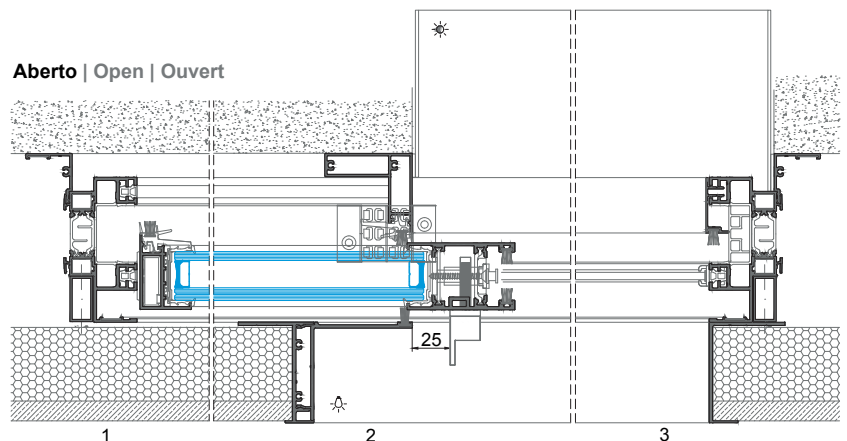

**JANELA DE CORRER 2 FOLHAS DE EMBUTIR 2-RAIL CANTO 90° - LINHA FR**  
2 SASHES POCKET 2-RAIL SLIDING WINDOW 90° CORNER - FR LINE  
FENÊTRE COULISSANT 2 VANTAUX À GALANDAGE 2-RAIL EN ANGLE 90° - LIGNE FR

PERFIS   PROFILES   PROFILÉS					
CÓDIGO CODE / CODE	DESIGNAÇÃO DESIGNATION / NOMINATION	CORTE HORIZ. HORIZONTAL CUT COUPE HORIZ.	CORTE VERT. VERTICAL CUT COUPE VERTICALE	QUANT. QUANTITY QUANTITÉ	CORTE CUT COUPE
JT 02	ARO FIXO FIXED FRAME   CADRE DORMANT	2L1-66 2L2-78	H	2 2+2	
JT 51	PERFIL CENTRAL CENTRAL PROFILE   PROFILÉ CENTRAL	-	H-81	2	
JT 62	PERFIL LATERAL CANTO 90° 90° CORNER LAT. PR.   PR. LAT. D'ANGLE À 90°	-	H-81	2	
JT 63	TRAVESSA SUP/INF UP/LW TRAVERSAUM / TRAVERSE SUP/INF	L1-125 L2-137	-	2 2	
JT 72	PERFIL LIGAÇÃO CANTO 90° CONNECTION PROFILE   PROFILÉ DE LIAISON	-	H-150	1	
JT 85	CAPA COVER   CAPOT	L1-1 L2-1	-	2 2	
JT 87	GUIA GUIDE	2L1-120 2L2-188	-	1	
JT 93	PERFIL MONTANTE MULLION PROFILE   PROFILÉ DE MENEAU	-	H-106	2	
SO 46	PERFIL REMATE FINISHING PROFILE   PROFILÉ DE FINITION	-	H-97	2	
SO 47	PERFIL REMATE FINISHING PROFILE   PROFILÉ DE FINITION	-	H-97	2	
SO 48	PERFIL REMATE FINISHING PROFILE   PROFILÉ DE FINITION	L1-12 L2-12	-	2 2	
KE 71	PERFIL REMATE FINISHING PROFILE   PROFILÉ DE FINITION	L1+109 L2+109	-	1 1	
KE 90	PERFIL REMATE FINISHING PROFILE   PROFILÉ DE FINITION	(2xL1)-25 L1-41 (2xL2)-38 L2-53	H+50	1 1 1+2 1	
KP 32	TUBO TUBE   TUBE	Variable   Variable   Variable			
208346	JUNTA CENTRAL 2196 CENTRAL JOINT   JOINT CENTRALE	-	H-106 H-81	2 2	
215305	PERFIL PVC U U PVC PROFILE   PROFILÉ PVC U	2L1-103 2L2-116	H-49	2 2+2	
215303	PERFIL PVC T T PVC PROFILE   PROFILÉ PVC T	L1-123 L1-137 L2-123 L2-137	-	1 1 1 1	

VEDANTES   SEALS   JOINTS		
CÓDIGO CODE / CODE	DESIGNAÇÃO DESIGNATION / NOMINATION	QUANT. QUANTITY QUANTITÉ
208348	JUNTA TAPA CANAL 2116 JT JOINT JOINT	2L1 2L2+4H
208099	JUNTA VIDRO U 1032 CX 32MM JT GLAZING GASKET   JOINT DE VITRAGE	2L1, 4H 2L2, 4H
208307	PELUCIA 7x10 TRI-FIN PRETA PILE SEAL   JOINT BRUSSE	6L1, 9H 6L2
208479	JUNTA TAPA CANAL PERFIL LIG. 2117 JT JOINT JOINT	H
208435	JUNTA VD 2415 JOINT JOINT	H
208466	PELUCIA 7x12 STOP-FIN PRETA PILE SEAL   JOINT BRUSSE	2H

ACESSÓRIOS   ACCESSORIES   ACCESSOIRES		
CÓDIGO CODE / CODE	DESIGNAÇÃO DESIGNATION / NOMINATION	QUANT. QUANTITY QUANTITÉ
205129	CARRINHO JT 180KG ROLLER   ROULETTE	4
213286	CORTA-VENTO JT CENTRAL WATERPROOFING BRUSH   BRUSSE CENTRALE D'ETANCHÉITÉ	4
213287	CORTA-VENTO CANTO 90° JT 90° CORNER WATERPROOFING BRUSH   BRUSSE D'ETANCHÉITÉ ANGLE 90°	2
212337	CONJ. ESTANQ. CORTA-VENTO JT CENTRAL WATERPROOFING BRUSH KIT   KIT BRUSSE CENTRALE D'ETANCHÉITÉ	4
204164	ESQUADRO JT 12x9.5 CORNER CLEAT   LEQUERRE	8
213014	CANTO ALINHAMENTO JT ALIGNMENT CORNER   ANGLE D'ALIGNEMENT	4
212243	CONJ. UNIÃO CANTO 90° JT 90° CORNER UNION KIT   KIT D'UNION ANGLE 90°	1
204389	ESQUADRO INOX CANTO 90° 90° STAINLESS STEEL CORNER   ANGLE EN ACIER INOXYDABLE 90°	2
213246	CANTO CR S/SB CORNER   ANGLE	8
212199	CONJ. TOPOS LAT. JT LATERAL END-CAPS KIT   KIT D'EMBOUTS LATÉRAUX	2
212230	CONJ. TOPOS INTERIOR LAT. JT INNER END-CAPS KIT   KIT D'EMBOUTS INTÉRIEUR LATÉRAUX	1
212201	CONJ. TAMPAS TOPOS LAT. JT LATERAL END-CAP COVERS KIT   KIT DE COUVERTURE POUR EMBOUTS LATÉRAUX	1
212231	CONJ. TOPOS CENTRAIS JT CENTRAL END-CAPS KIT   KIT D'EMBOUTS CENTRAUX	2
212339	CONJ. TAMPAS TOPOS CENTRAIS JT CENTRAL END-CAP COVERS KIT   KIT DE COUVERTURE POUR EMBOUTS CENTRAUX	2
212109	CONJ. TOPOS CANTO 90° JT 90° CORNER END-CAPS KIT   KIT D'EMBOUTS POUR ANGLE 90°	1
210269	GOTEIRA OCULTA C/ VALV. SV-C13 FLAP VALVE   CLAPE À VOLET CACHE	(a)
211223	FERRAGEM MULTIPONTO CENTR. 1000 MULTIPOINT HARDWARE   SERRURE MULTIPONT	1
202491	CONTRA-FECHO ANTI-LEVANTAMENTO MULTIPONTO STRIKING PLATE   GÂCHE	2
212458	CONJ. FIX. CONTRA-FECHO MULTIP. 2F/90° JT MULTIPOINT HARDWARE STRIKING PLATE FIXING KIT   KIT FIXATION GÂCHE SERRURE MULTIP.	2
218154	CALÇO P/ C-FECHO PERF. LIG CONNECTING PROFILE STRIKING PLATE SHIM   CALE POUR GÂCHE PROFILÉ DE LIAISON	2
218196	CALÇO P/ MULTIPONTO SOS JT MULTIPOINT HARDWARE SHIM   CALE POUR MULTIPONT	6
212162	CONJ. CENTRADOR P/ FERRAGEM JT PERFIL LIG. CENTERING KIT FOR JT HARDWARE   KIT CENTRAGE POUR SERRURE JT	1
212371	CONJ. FIXAÇÃO JT FIXING KIT   KIT FIXATION	6
212079	CONJ. FIX. FERRAGEM MULTIP. JT72 MULTIPOINT FIXING KIT   KIT FIXATION SERRURE MULTIPONT	1 + 1 un./m (min. 4)
200817	PUXADOR SLIM XS - DIREITO RIGHT HANDLE   POIGNÉE DROITE	1
212085	CONJ. TOPOS JT93 JT93 END-CAPS KIT   KIT D'EMBOUTS JT93	2
212221	CONJ. TAPA TOPOS KE71 KIT END-CAPS KIT   KIT D'EMBOUTS KE71	1
212227	CONJ. JUNTAS ADES. P/ TOPOS PERFIL SOL. KE71 KE71 ADHESIVE JOINTS KIT   KIT DE JOINTS ADHÉSIFS KE71	1
212223	CONJ. TOPOS INFERIORES RENOVATIO RENOVATIO END-CAPS KIT   KIT D'EMBOUTS INFÉRIEUR RENOVATIO	1
290262	PARAFUSO FK INOX PH 1 1/2X10 CQ SCREW   VIS	16
218137	CALÇO REFORÇO HORIZONTAL JT * HORIZONTAL REINFORCEMENT SHIM   CALE DE RENFORCEMENT HORIZONTALE	4

\* Usar em folhas com vidros com peso superior a 80kg  
To be used in sashes which glass weight exceed 80kg | Utiliser dans des panneaux de verre d'un poids supérieur à 80 kg  
(a) Conforme esquemas de drenagem (Capítulo V - Maquinações)  
According to drainage schemes (Chapter V - Machinings) | Selon les schémas de drainage (Chapitre V - Usinages)

As fórmulas foram concebidas para medidas de vidros iguais.  
Nesta tipologia existem 2 larguras de folha distintas: Lf1 e Lf2.  
The formulas were designed for glasses with equal measures.  
In this typology there are 2 distinct sash widths: Lf1 and Lf2.  
Les formules sont conçues pour mesurer le verre. Dans cette typologie, il existe 2 largeurs de vantaux distinctes: Lf1 et Lf2.

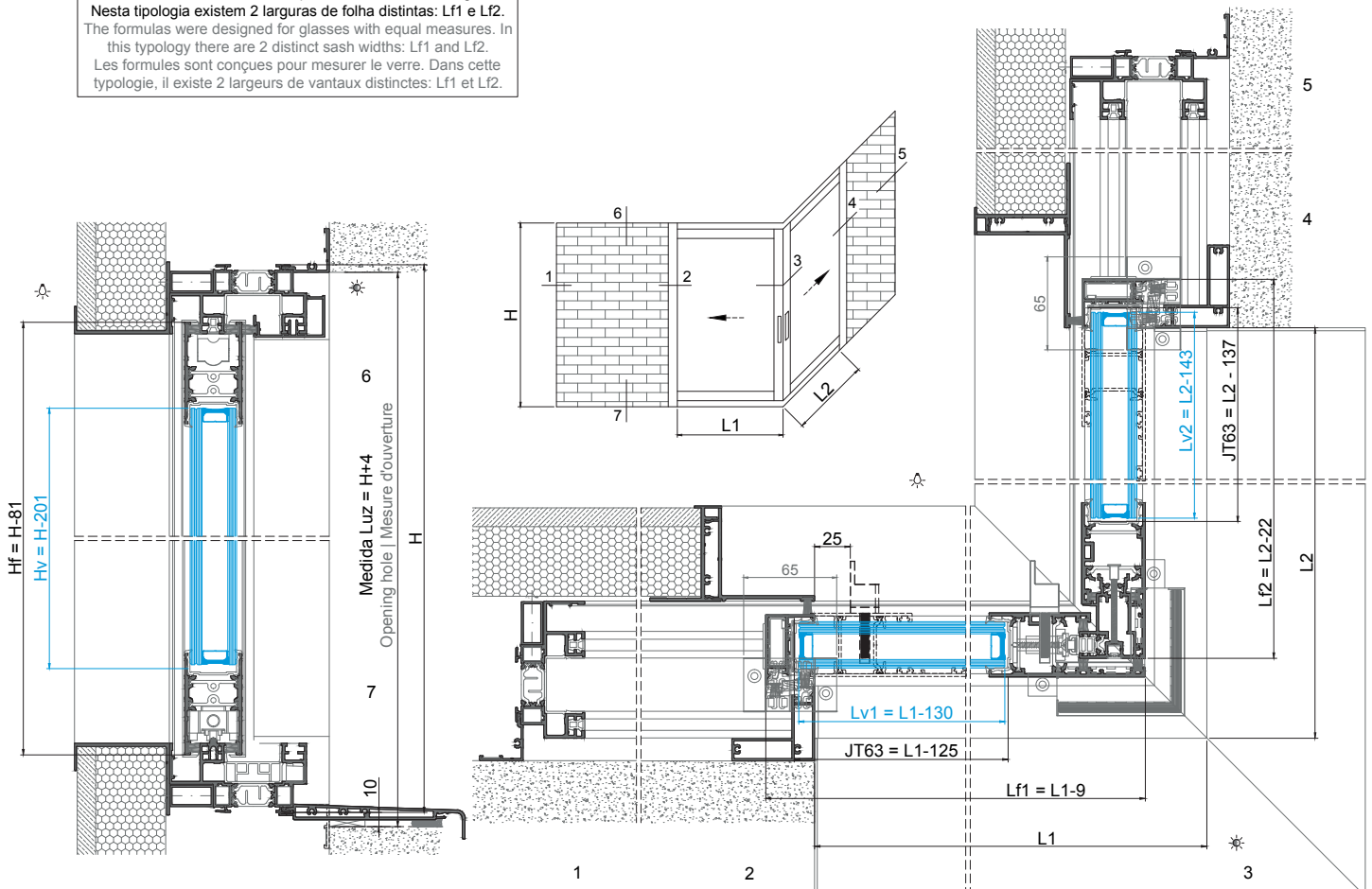



**JANELA DE CORRER 4 FOLHAS DE EMBUTIR 3-RAIL COM LIGAÇÃO CENTRAL - LINHA FR**  
4 SASHES POCKET 3-RAIL SLIDING WINDOW WITH CENTRAL CONNECTION - FR LINE  
FENÊTRE COULISSANT 4 VANTAUX 3-RAIL À GALANDAGE AVEC CONNEXION CENTRALE - LIGNE FR

PERFIS   PROFILÉS   PROFILÉS					
CÓDIGO CODE   CODE	DESIGNAÇÃO DESIGNATION   NOMINATION	CORTE HORIZ. HORIZONTAL CUT COUPE HORIZ.	CORTE VERT. VERTICAL CUT COUPE VERTICALE	QUANT. QUANTITY QUANTITE	CORTE CUT COUPE
JT 03	ARO FIXO FIXED FRAME   CADRE DORMANT	(3L+257)/2	H	2 + 2	
JT 51	PERFIL CENTRAL CENTRAL PROFILE   PROFILÉ CENTRAL	-	H-81	4	
JT 53	PERFIL CENTRAL CENTRAL PROFILE   PROFILÉ CENTRAL	-	H-81	2	
JT 67	PERFIL LATERAL LATERAL PROFILE   PROFILÉ LATÉRAL	-	H-81	2	
JT 63	TRAVESSA SUP/INF UP/LOW TRANSOM   TRAVERSE SUP/INF	(L-107)/4 (L-104)/4	-	4 4	
JT 71	PERFIL LIGAÇÃO CENTRAL CONNECTION PROFILE   PROFILÉ DE LIAISON	-	H-149	1	
JT 85	CAPA COVER   CAPOT	(L-76)/4	-	4	
JT 88	CAPA COVER   CAPOT	(L+71)/2	-	2	
JT 87	GUIA GUIDE   GUIDE	(3L+61)/2 (L-4)/2	-	1 2	
JT 93	PERFIL MONTANTE MULTIJOIN PROFILE   PROFILÉ DE MENEAU	-	H-106	2	
SO 46	PERFIL REMATE FINISHING PROFILE   PROFILÉ DE FINITION	-	H-97	2	
SO 47	PERFIL REMATE FINISHING PROFILE   PROFILÉ DE FINITION	-	H-97	2	
SO 48	PERFIL REMATE FINISHING PROFILE   PROFILÉ DE FINITION	L+158	-	2	
KE 71	PERFIL REMATE FINISHING PROFILE   PROFILÉ DE FINITION	L-6	-	1	
KE 90	PERFIL REMATE FINISHING PROFILE   PROFILÉ DE FINITION	(3L+357)/2 (L+357)/4	H+50	1 2 + 2	
KP 32	TUBO TUBE   TUBE	Variável   Variable   Variable	Variable   Variable	Variable   Variable	
208346	JUNTA CENTRAL 2196 CENTRAL JOINT   JOINT CENTRALE	-	H-106 H-81	2 6	
215305	PERFIL PVC U U PVC PROFILE   PROFILÉ PVC U	(3L+175)/2	H-40	4 + 4	
215303	PERFIL PVC T T PVC PROFILE   PROFILÉ PVC T	(L-54)/2 (L-112)/4 L-27 L-31	-	2 2 2 1	

ACESSÓRIOS   ACCESSORIES   ACCESSOIRES		
CÓDIGO CODE   CODE	DESIGNAÇÃO DESIGNATION   NOMINATION	QUANT. QUANTITY QUANTITE
205129	CARRINHO JT 180KG ROLLER   ROULETTE	8
213286	CORTA-VENTO JT CENTRAL WATERPROOFING BRUSH   BROSE CENTRALE D'ETANCHÉITÉ	10
212337	CONJ. ESTANQ. CORTA-VENTO JT CENTRAL WATERPROOFING BRUSH KIT   KIT BROSE CENTRALE D'ETANCHÉITÉ	5
204164	ESQUADRO JT 12x9,5 CORNER CLEAT   ÉQUERRE	12
213014	CANTO ALINHAMENTO JT ALIGNMENT CORNER   ANGLE D'ALIGNEMENT	4
213246	CANTO CR S/SB CORNER   ANGLE	8
212199	CONJ. TOPOS LAT. JT LATERAL END-CAPS KIT   KIT D'EMBOUTS LATÉRAUX	2
212230	CONJ. TOPOS INTERIOR LAT. JT LATERAL INNER END-CAPS KIT   KIT D'EMBOUTS INTÉRIEUR LATÉRAUX	1
212201	CONJ. TAMPAS TOPOS LAT. JT LATERAL END-CAP COVERS KIT   KIT DE COUVERTURE POUR EMBOUTS LATÉRAUX	1
212231	CONJ. TOPOS CENTRAIS JT CENTRAL END-CAPS KIT   KIT D'EMBOUTS CENTRAUX	6
212339	CONJ. TAMPAS TOPOS CENTRAIS JT CENTRAL END-CAP COVERS KIT   KIT DE COUVERTURE POUR EMBOUTS CENTRAUX	6
210241	TOPO CENTRAL REFORÇADO 28MM 28MM CENTRAL REINFORCED END-CAPS KIT   KIT D'EMBOUTS CENTRAUX RENFORCÉ 28MM	4
212104	CONJ. TOPOS LIG. 2 FOLHAS JT 2 SASHES CONNECTING END-CAPS KIT   KIT D'EMBOUTS CONNEXION 2 VENTAUX	1
210269	CATENA OCULTA C/ VALV. SV-C13 FLAP VALVE   CLAPE À VOLET CACHÉ	(a)
211223	FERRAGEM MULTIPONTO CENTRAL. 1000 MULTIPOINT HARDWARE   SERRURE MULTIPOINT	1
202491	CONTRA-FECHO ANTI-LEVANTAMENTO MULTIPONTO STRIKING PLATE   GÂCHE	2
212458	CONJ. FIX. CONTRA-FECHO MULTIP. 2F/90° JT FIXING KIT FOR MULTIP. STRIKING PLATE-FIXING KIT   KIT FIXATION GÂCHE SERRURE MULTIP.	2
218154	CALÇO P/ C- FECHO PERE. LIG. CONNECTING PROFILE STRIKING PLATE SHIM   CALE POUR GÂCHE PROFILÉ DE LIAISON	2
218198	CALÇO P/ MULTIPONTO SOS JT MULTIPOINT HARDWARE SHIM   CALE POUR MULTIPONTO	6
212162	CONJ. CENTRADOR P/ FERRAGEM JT PERFIL LIG. CENTERING KIT FOR JT HARDWARE   KIT CENTRAGE POUR SERRURE JT	1
212371	CONJ. FIXAÇÃO JT FIXING KIT   KIT FIXATION	6
212017	CONJ. FIX. FERRAGEM MULTIP. MULTIPOINT HARDWARE FIXING KIT   KIT FIXATION POUR SERRURE MULTIPOINT	1 + 1 un./m (min. 4)
200817	PUXADOR SLIM XS - DIREITO RIGHT HANDLE   POIGNÉE DROITE	1
200057	PUXADOR FOLHA PASSIVA SLIM XS PASSIVE SASH HANDLE   POIGNÉE VENTALE PASSIVE	1
212085	CONJ. TOPOS JT93 JT93 END-CAPS KIT   KIT D'EMBOUTS JT93	2
212221	CONJ. TAPA TOPOS KE71 KE71 END-CAPS KIT   KIT D'EMBOUTS KE71	1
212227	CONJ. JUNTAS ADES. P/ TOPOS PERFIL SOL. KE71 KE71 ADHESIVE JOINTS KIT   KIT DE JOINTS ADHÉSIFS KE71	1
212223	CONJ. TOPOS INFERIORES RENOVATIO RENOVATIO END-CAPS KIT   KIT D'EMBOUTS INTÉRIEUR RENOVATIO	1
290262	PARAFUSO PK INOX PH 1 1/2X10 CQ SCREW   VIS	32
218137	CALÇO REFORÇO HORIZONTAL JT * HORIZONTAL REINFORCEMENT SHIM   CALE DE RENFORCEMENT HORIZONTALE	8

\* Usar em folhas com vidros com peso superior a 80kg  
TO BE USED IN SASHES WHICH GLASS WEIGHT EXCEEDS 80KG | Utiliser dans des panneaux de verre d'un poids supérieur à 80 kg  
(a) Conforme esquemas de drenagem (Capítulo V - Maquinações)  
According to drainage schemes (Chapter V - Machinings) | Selon les schémas de drainage (Chapitre V - Usinages)

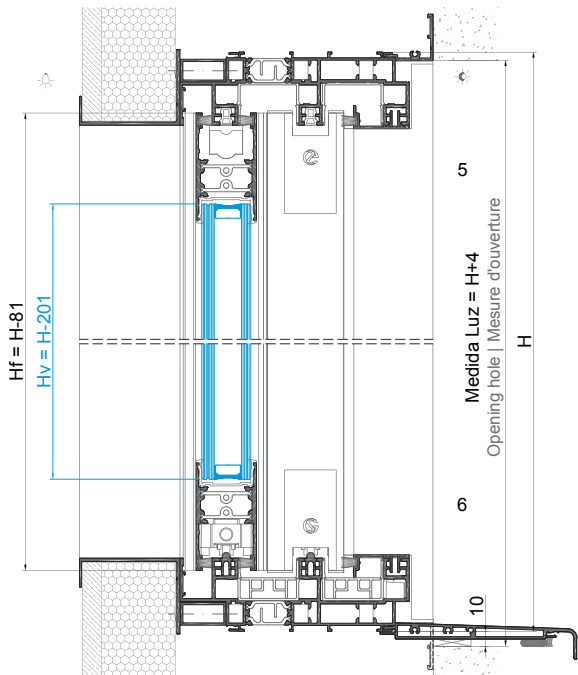

VEDANTES   SEALS   JOINTS		
CÓDIGO CODE   CODE	DESIGNAÇÃO DESIGNATION   NOMINATION	QUANT. QUANTITY QUANTITE
208348	JUNTA TAPA CANAL 2116 JT JOINT   JOINT	4L + 6H
208099	JUNTA VIDRO U 1032 CX 32MM JT GLAZING GASKET   JOINT DE VITRAGE	2L + 8H
208307	PELUCIA 7x10 TRI-FIN PRETA PILE SEAL   JOINT GROSSE	10L + 12H
208466	PELUCIA 7x12 STOP-FIN PRETA PILE SEAL   JOINT GROSSE	2H

As fórmulas foram concebidas para medidas de vidros iguais. Nesta tipologia existem 2 larguras de folha distintas: Lf1 e Lf2.  
The formulas were designed for glasses with equal measures. In this typology there are 2 distinct sash widths: Lf1 and Lf2.  
Les formules sont conçues pour mesurer le verre. Dans cette typologie, il existe 2 largeurs de vantaux distinctes: Lf1 et Lf2.

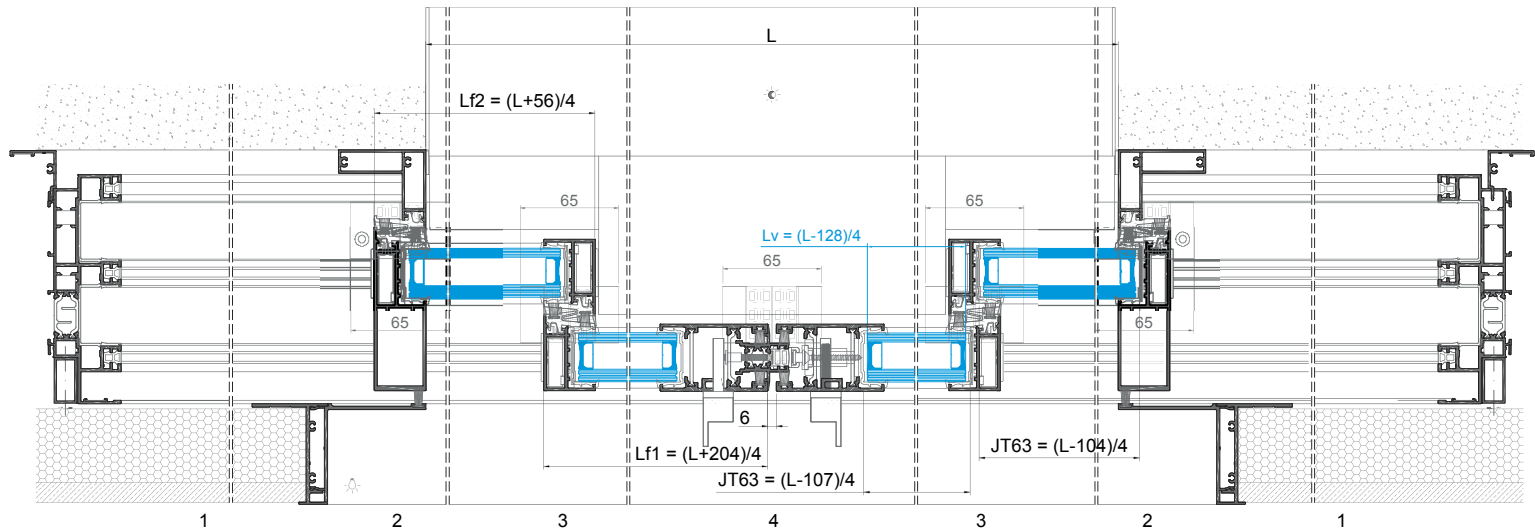
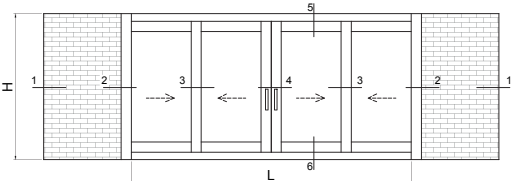

**JANELA DE CORRER 2 FOLHAS 2-RAIL - LINHA PT**  
2 SASHES 2-RAIL SLIDING WINDOW - PT LINE  
FENÊTRE COULISSANT 2 VANTAUX 2-RAIL - LIGNE PT

PERFIS   PROFILES   PROFILÉS					
CÓDIGO CODE   CODE	DESIGNAÇÃO DESIGNATION   NOMINATION	CORTE HORIZ. HORIZONTAL CUT COUPE HORIZ.	CORTE VERT. VERTICAL CUT COUPE VERTICALE	QUANT. QUANTITY QUANTITÉ	CORTE CUT COUPE
JT 12	ARO FIXO FIXED FRAME   CADRE DORMANT	L	H	2 + 2	
JT 54	PERFIL CENTRAL CENTRAL PROFILE   PROFILÉ CENTRAL	-	H-74	2	
JT 67	PERFIL LATERAL LATERAL PROFILE   PROFILÉ LATÉRAL	-	H-74	2	
JT 63	TRAVESSA SUP/INF UP/LW TRANSOM   TRAVERSE SUP/INF	(L-196)/2	-	4	
JT 82	PERFIL PINGADEIRA DRIP PROFILE   L'ARMIER	L-4	-	1	
JT 90	CAPA COVER   CAPOT	-	H-37	1	
JT 92	CAPA COVER   CAPOT	-	H-37	1	
JT 87	GUIA GUIDE   GUIDE	L-93	-	2	
208346	JUNTA CENTRAL 2196 CENTRAL JOINT   JOINT CENTRALE	-	H-74	2	
215305	PERFIL PVC U U PVC PROFILE   PROFILÉ PVC U	L-34	H-34	2 + 2	
215303	PERFIL PVC T T PVC PROFILE   PROFILÉ PVC T	(L-130)/2	H-37	2 + 2	

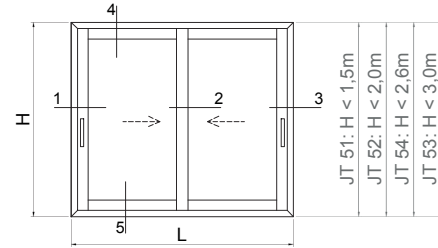

DESEMPENHO DO SISTEMA SYSTEM PERFORMANCE PERFORMANCE DU SYSTÈME	
Permeabilidade ao AR AIR Permeability Perméabilité à l'AIR	4
Estanquidade à ÁGUA WATER Tightness Étanchéité à l'EAU	7A
Resistência ao VENTO WIND Resistance Résistance au VENT	C3

ACESSÓRIOS   ACCESSORIES   ACCESSOIRES		
CÓDIGO CODE   CODE	DESIGNAÇÃO DESIGNATION   NOMINATION	QUANT. QUANTITY QUANTITÉ
205129	CARRINHO JT 180KG ROLLER   ROULETTE	4
213286	CORTA-VENTO JT CENTRAL WATERPROOFING BRUSH   Brosse CENTRALE D'ÉTANCHÉITÉ	2
212337	CONJ. ESTANQ. CORTA-VENTO JT CENTRAL WATERPROOFING BRUSH KIT   KIT Brosse CENTRALE D'ÉTANCHÉITÉ	1
204153	ESQUADRO JT 1x20,5 CORNER CLEAT   ÉQUERRE	8
213246	CANTO CR S/SB CORNER   ANGLE	4
212199	CONJ. TOPOS LAT. JT LATERAL END-CAPS KIT   KIT D'EMBOUITS LATÉRAUX	2
212230	CONJ. TOPOS INTERIOR LAT. JT LATERAL INNER END-CAPS KIT   KIT D'EMBOUITS INTÉRIEUR LATÉRAUX	2
212201	CONJ. TAMPAS TOPOS LAT. JT LATERAL END-CAP COVERS KIT   KIT DE COUVERTURE POUR EMBOUITS LATÉRAUX	2
212231	CONJ. TOPOS CENTRAIS JT CENTRAL END-CAPS KIT   KIT D'EMBOUITS CENTRAUX	2
212339	CONJ. TAMPAS TOPOS CENTRAIS JT CENTRAL END-CAP COVERS KIT   KIT DE COUVERTURE POUR EMBOUITS CENTRAUX	2
210243	TOPO CENTRAL REFORÇADO JT54 28MM 28MM CENTRAL REINFORCED END-CAPS KIT   KIT D'EMBOUITS CENTRAUX RENFORCÉ 28MM	4
210268	GOTEIRA C/ VALV. SVE OUTSIDE FLAP VALVE   CLAPE À VOLET EXTÉRIEUR	(a)
211223	FERRAGEM MULTIPONTO CENTR. 1000 MULTIPOINT HARDWARE   SERRURE MULTIPOINT	2
202491	CONTRA-FECHO ANTI-LEVANTAMENTO MULTIPONTO STRIKING PLATE   GÂCHE	4
202487	CENTRADOR JT P/ C-FECHO AL MULTIPONTO JT CENTERING FOR STRIKING PLATE   CENTRAGE JT POUR GÂCHE	4
212455	CONJ. FIX. CONTRA-FECHO AL MULTIP. JT MULTIPOINT HARDWARE STRIKING PLATE FIXING KIT   KIT FIXATION GÂCHE SERRURE MULTIPOINT	4
218198	CALÇO P/ MULTIPONTO SOS JT MULTIPOINT HARDWARE SHIM   CALE POUR MULTIPOINT	12
212161	CONJ. CENTRADOR P/ FERRAGEM JT CENTERING KIT FOR JT HARDWARE   KIT CENTRAGE POUR SERRURE JT	2
212371	CONJ. FIXAÇÃO JT FIXING KIT   KIT FIXATION	12
200819	PUXADOR SLIM XS - ESQUERDO LEFT HANDLE   POIGNÉE GAUCHE	1
200817	PUXADOR SLIM XS - DIREITO RIGHT HANDLE   POIGNÉE DROITE	1
212384	CONJ. TOPOS LAT. PINGADEIRA JT82 LATERAL DRIP END-CAPS KIT   KIT D'EMBOUITS LATÉRAUX POUR REJET D'EAU	1
228107	LIMITADOR ABERT. PQ SERIE CORRER OPENING LIMITER   LIMITEUR D'OUVERTURE	1
290262	PARAFUSO PK INOX PH 1 1/2x10 CQ SCREW   VIS	16
218137	CALÇO REFORÇO HORIZONTAL JT * HORIZONTAL REINFORCEMENT SHIM   CALE DE RENFORCEMENT HORIZONTALE	4

\* Usar em folhas com vidros com peso superior a 80kg  
To be used in sashes which glass weight exceed 80kg | Utiliser dans des panneaux de verre d'un poids supérieur à 80 kg  
(a) Conforme esquemas de drenagem (Capítulo V - Maquinações)  
According to drainage schemes (Chapter V - Machinings) | Selon les schémas de drainage (Chapitre V - Usinages)

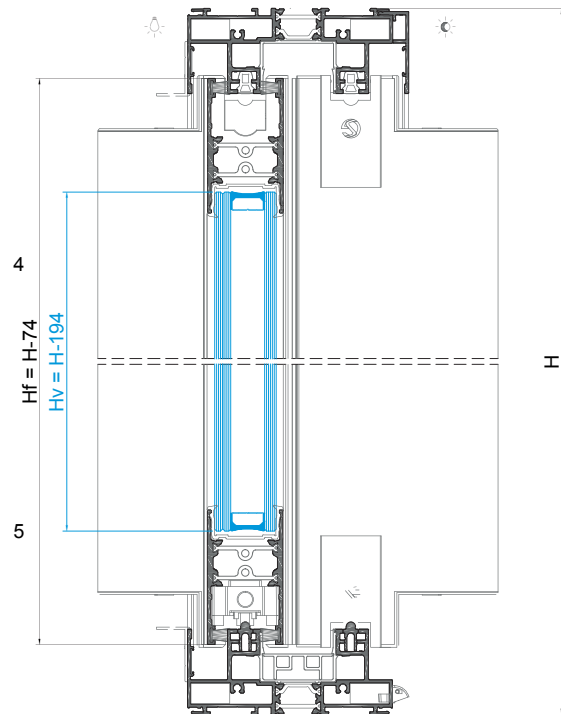

VEDANTES   SEALS   JOINTS		
CÓDIGO CODE   CODE	DESIGNAÇÃO DESIGNATION   NOMINATION	QUANT. QUANTITY QUANTITÉ
208348	JUNTA TAPA CANAL 2116 JT JOINT   JOINT	2L + 2H
208099	JUNTA VIDRO U 1032 CX 32MM JT GLAZING GASKET   JOINT DE VITRAGE	2L + 4H
208307	PELUCIA 7x10 TRI-FIN PRETA PILE SEAL   JOINT BROSSE	4L + 8H

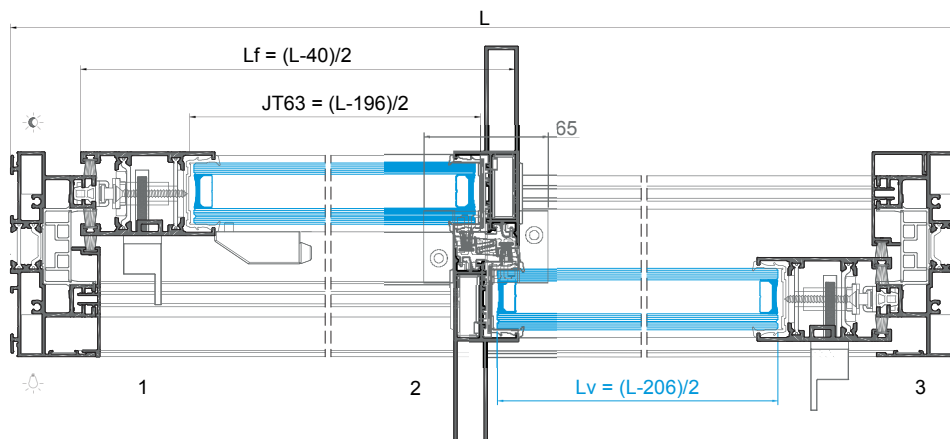

**JANELA DE CORRER 3 FOLHAS 2-RAIL - LINHA PT**  
3 SASHES 2-RAIL SLIDING WINDOW - PT LINE  
FENÊTRE COULISSANT 3 VANTAUX 2-RAIL - LIGNE PT

PERFIS   PROFILES   PROFILÉS					
CÓDIGO CODE   CODE	DESIGNAÇÃO DESIGNATION   NOMINATION	CORTE HORIZ. HORIZONTAL CUT COUPE HORIZ.	CORTE VERT. VERTICAL CUT COUPE VERTICALE	QUANT. QUANTITY QUANTITE	CORTE CUT COUPE
JT 12	ARO FIXO FIXED FRAME   CADRE DORMANT	L	H	2 + 2	
JT 54	PERFIL CENTRAL CENTRAL PROFILE   PROFILÉ CENTRAL	-	H-74	4	
JT 67	PERFIL LATERAL LATERAL PROFILE   PROFILÉ LATÉRAL	-	H-74	2	
JT 63	TRAVESSA SUP/INF UP/LW TRANSOM   TRAVERSE SUP/INF	(L-202)/3 (L-200)/3	-	4 2	
JT 82	PERFIL PINGADEIRA DRIP PROFILE   LARMIER	L-4	-	1	
JT 92	CAPA COVER   CAPOT	-	H-37	2	
JT 87	GUIA GUIDE   GUIDE	L-96 L-90	-	1 1	
208346	JUNTA CENTRAL 2196 CENTRAL JOINT   JOINT CENTRALE	-	H-74	4	
215305	PERFIL PVC U U PVC PROFILE   PROFILÉ PVC U	L-34	H-34	2 + 2	
215303	PERFIL PVC T T PVC PROFILE   PROFILÉ PVC T	(L-103)/3 (L-377)/3	H-37	2 1 + 2	

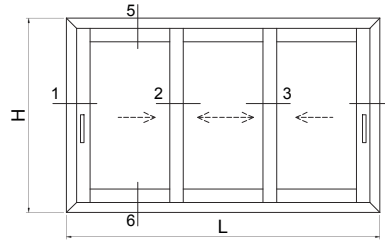

ACESSÓRIOS   ACCESSORIES   ACCESSOIRES		
CÓDIGO CODE   CODE	DESIGNAÇÃO DESIGNATION   NOMINATION	QUANT. QUANTITY QUANTITE
205129	CARRINHO JT 180KG CARRIAGE	6
213286	CORTA-VENTO JT CENTRAL WATERPROOFING BRUSH   BROSSE CENTRALE D'ÉTANCHÉITÉ	4
212337	CONJ. ESTANQ. CORTA-VENTO JT CENTRAL WATERPROOFING BRUSH KIT   KIT BROSSE CENTRALE D'ÉTANCHÉITÉ	2
204153	ESQUADRO JT 11x20.5 CORNER GLASS   ÉQUERRE	8
213246	CANTO CR SSB CORNER   ANGLE	4
212199	CONJ. TOPOS LAT. JT LATERAL END-CAPS KIT   KIT D'EMBOUS LATÉRAUX	2
212230	CONJ. TOPOS INTERIOR LAT. JT LATERAL INNER END-CAPS KIT   KIT D'EMBOUS INTÉRIEUR LATÉRAUX	2
212201	CONJ. TAMPAS TOPOS LAT. JT LATERAL END-CAP COVERS KIT   KIT DE COUVERTURE POUR EMBOUTS LATÉRAUX	2
212231	CONJ. TOPOS CENTRAIS JT CENTRAL END-CAPS KIT   KIT D'EMBOUS CENTRAUX	4
212339	CONJ. TAMPAS TOPOS CENTRAIS JT CENTRAL END-CAP COVERS KIT   KIT DE COUVERTURE POUR EMBOUTS CENTRAUX	4
210243	TOPO CENTRAL REFORÇADO JT54 28MM 38MM CENTRAL REINFORCED END-CAPS KIT   KIT D'EMBOUS CENTRAUX REINFORÇÉ 28MM	8
210268	GOTEIRA C/ VALV. SVE OUTSIDE FLAP VALVE   CLAPE À VOLET EXTÉRIEUR	(a)
211223	FERRAGEM MULTIPONTO CENTR. 1000 MULTIPOINT HARDWARE   SERRURE MULTIPONTO	2
202491	CONTRA-FECHO ANTI-LEVANTAMENTO MULTIPONTO STRIKING PLATE   GÂCHE	4
202487	CENTRADOR JT P/ C-FECHO AL MULTIPONTO JT CENTERING FOR STRIKING PLATE   CENTRAGE JT POUR GÂCHE	4
212455	CONJ. FIX. CONTRA-FECHO AL MULTIP. JT MULTIPOINT HARDWARE STRIKING PLATE FIXING KIT   KIT FIXATION GÂCHE SERRURE MULTIPONTO	4
218198	CALÇO P/ MULTIPONTO SOS JT MULTIPOINT HARDWARE SHIM   CALE POUR MULTIPONTO	12
212161	CONJ. CENTRADOR P/ FERRAGEM JT CENTERING KIT FOR JT HARDWARE   KIT CENTRAGE POUR SERRURE JT	2
212371	CONJ. FIXAÇÃO JT FIXING KIT   KIT FIXATION	12
200819	PUXADOR SLIM XS - ESQUERDO LEFT HANDLE   POIGNÉE GAUCHE	1
200817	PUXADOR SLIM XS - DIREITO RIGHT HANDLE   POIGNÉE DROITE	1
212384	CONJ. TOPOS LAT. PINGADEIRA JT82 LATERAL DRIP END-CAPS KIT   KIT D'EMBOUS LATÉRAUX POUR REJET D'EAU	1
290262	PARAFUSO PK INOX PH 1 1/2X10 CQ SCREW   VIS	24
218137	CALÇO REFORÇO HORIZONTAL JT * HORIZONTAL REINFORCEMENT SHIM   CALE DE RENFORCEMENT HORIZONTALE	6

\* Usar em folhas com vidros com peso superior a 80kg  
To be used in sashes which glass weight exceed 80kg | Utiliser dans des panneaux de verre d'un poids supérieur à 80 kg

(a) Conforme esquemas de drenagem (Capítulo V - Maquinações)  
According to drainage schemes (Chapter V - Machinings) | Selon les schémas de drainage (Chapitre V - Usinages)

VEDANTES   SEALS   JOINTS		
CÓDIGO CODE   CODE	DESIGNAÇÃO DESIGNATION   NOMINATION	QUANT. QUANTITY QUANTITE
208348	JUNTA TAPA CANAL 2116 JT JOINT   JOINT	2L + 2H
208099	JUNTA VIDRO U 1032 CX 32MM JT GLAZING GASKET   JOINT DE VITRAGE	2L + 6H
208307	PELUCIA 7x10 TRI-FIN PRETA PILE SEAL   JOINT BRUSSE	4L + 10H

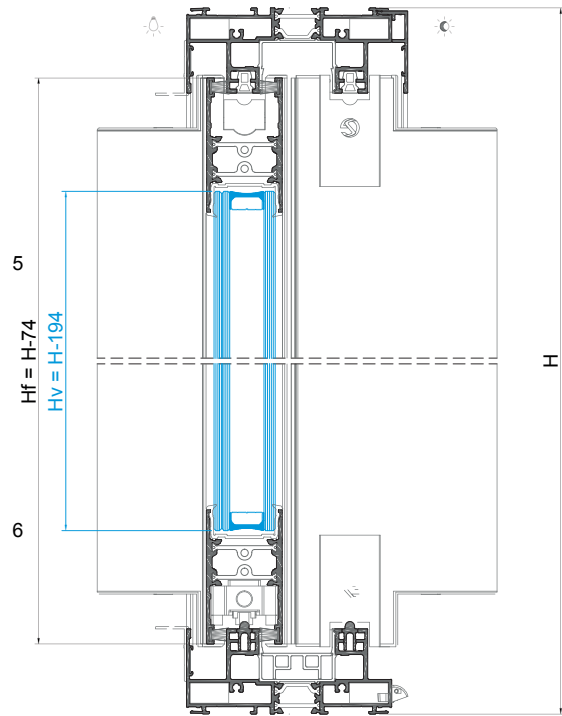

As fórmulas foram concebidas para medidas de vidros iguais.  
Nesta tipologia existem 2 larguras de folha distintas: Lf1 e Lf2.  
The formulas were designed for glasses with equal measures. In this typology there are 2 distinct sash widths: Lf1 and Lf2.  
Les formules sont conçues pour mesurer le verre. Dans cette typologie, il existe 2 largeurs de vantaux distinctes: Lf1 et Lf2.

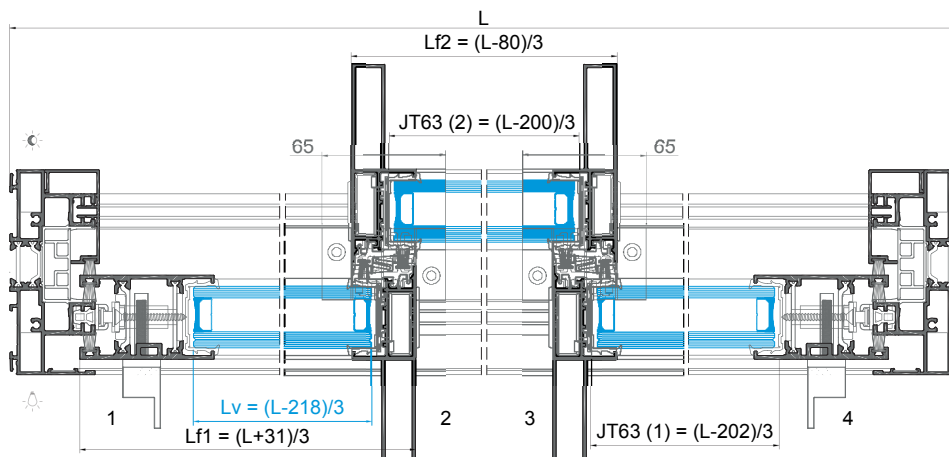

**JANELA DE CORRER 4 FOLHAS 2-RAIL COM LIGAÇÃO CENTRAL - LINHA PT**  
4 SASHES 2-RAIL SLIDING WINDOW WITH CENTRAL CONNECTION - PT LINE  
FENÊTRE COULISSANT 4 VANTAUX 2-RAIL AVEC CONNEXION CENTRALE - LIGNE PT

PERFIS   PROFILES   PROFILÉS					
CÓDIGO CODE   CODE	DESIGNAÇÃO DESIGNATION   NOMINATION	CORTE HORIZ. HORIZONTAL CUT COUPE HORIZ.	CORTE VERT. VERTICAL CUT COUPE VERTICALE	QUANT. QUANTITY QUANTITE	CORTE CUT COUPE
JT 12	ARO FIXO FIXED FRAME   CADRE DORMANT	L	H	2 + 2	
JT 54	PERFIL CENTRAL CENTRAL PROFILE   PROFILÉ CENTRAL	-	H-74	4	
JT 67	PERFIL LATERAL LATERAL PROFILE   PROFILÉ LATÉRAL	-	H-74	4	
JT 63	TRAVESSA SUP/INF UP/DOWN TRANSOM   TRAVERSE SUP/INF	(L-324)/4	-	8	
JT 71	PERFIL LIGAÇÃO CENTRAL CONNECTION PROFILE   PROFILÉ DE LIAISON	-	H-143	1	
JT 82	PERFIL PINGADEIRA DRIP PROFILE   LARMIER	L-4	-	1	
JT 90	CAPA COVER   CAPOT	-	H-37	2	
JT 87	GUIA GUIDE   GUIDE	L-96 L-90	-	1	
208346	JUNTA CENTRAL 2196 CENTRAL JOINT   JOINT CENTRALE	-	H-74	4	
215305	PERFIL PVC U U PVC PROFILE   PROFILÉ PVC U	L-34	H-34	2 + 2	
215303	PERFIL PVC T T PVC PROFILE   PROFILÉ PVC T	(L-190)/4 (L-328)/4	H-37	2 + 2	

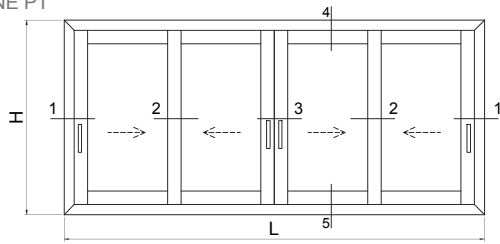

ACESSÓRIOS   ACCESSORIES   ACCESSOIRES		
CÓDIGO CODE   CODE	DESIGNAÇÃO DESIGNATION   NOMINATION	QUANT. QUANTITY QUANTITE
205129	CARRINHO JT 180KG ROLLER   ROULETTE	8
213286	CORTA-VENTO JT CENTRAL WATERPROOFING BRUSH   BROSSSE CENTRALE D'ÉTANCHÉITÉ	6
212337	CONJ. ESTANQ. CORTA-VENTO JT CENTRAL WATERPROOFING BRUSH KIT   KIT BROSSSE CENTRALE D'ÉTANCHÉITÉ	3
204153	ESQUADRO JT 11x20,5 CORNER GLEAT   ÉQUERRE	8
213246	CANTO CR S/SB CORNER   ANGLE	4
212199	CONJ. TOPOS LAT. JT LATERAL END-CAPS KIT   KIT D'EMBOUITS LATÉRAUX	4
212230	CONJ. TOPOS INTERIOR LAT. JT LATERAL INNER END-CAPS KIT   KIT D'EMBOUITS INTÉRIEUR LATÉRAUX	3
212201	CONJ. TAMPAS TOPOS LAT. JT LATERAL END-CAP COVERS KIT   KIT DE COUVERTURE POUR EMBOUTS LATÉRAUX	3
212231	CONJ. TOPOS CENTRAIS JT CENTRAL END-CAPS KIT   KIT D'EMBOUITS CENTRAUX	4
212339	CONJ. TAMPAS TOPOS CENTRAIS JT CENTRAL END-CAP COVERS KIT   KIT DE COUVERTURE POUR EMBOUTS CENTRAUX	4
210243	TOPO CENTRAL REFORÇADO JT54 28MM 28MM CENTRAL REINFORCED END-CAPS KIT   KIT D'EMBOUITS CENTRAUX RENFORCÉ 28MM	8
212104	CONJ. TOPOS LIG. 2 FOLHAS JT 2 SASHES CONNECTING END-CAPS KIT   KIT D'EMBOUITS CONNEXION 2 VANTAUX	1
210268	GOTEIRA C/ VALV. SVE OUTSIDE FLAP VALVE   GLAPE À VOLET EXTÉRIEUR	(a)
211223	FERRAGEM MULTIPONTO CENTR. 1000 MULTIPOINT HARDWARE   SERRURE MULTIPONT	3
202491	CONTRA-FECHO ANTI-LEVANTAMENTO MULTIPONTO STRIKING PLATE   GÂCHE	6
202487	CENTRADOR JT P/ C-FECHO AL MULTIPONTO JT CENTERING FOR STRIKING PLATE   CENTRAGE JT POUR GÂCHE	4
212455	CONJ. FIX. CONTRA-FECHO AL MULTIP. JT MULTIPONT HARDWARE STRIKING PLATE FIXING KIT   KIT FIXATION GÂCHE SERRURE MULTIPONT	4
212458	CONJ. FIX. CONTRA-FECHO MULTIP. 2F/90° JT MULTIPONT HARDWARE STRIKING PLATE FIXING KIT   KIT FIXATION GÂCHE SERRURE MULTIP.	2
218154	CALÇO P/ C-FECHO PERF. LIG CONNECTING PROFILE STRIKING PLATE SHIM   CALE POUR GÂCHE PROFILÉ DE LIAISON	2
218198	CALÇO P/ MULTIPONTO SÓS JT MULTIPONT HARDWARE SHIM   CALE POUR MULTIPONT	18
212161	CONJ. CENTRADOR P/ FERRAGEM JT CENTERING KIT FOR JT HARDWARE   KIT CENTRAGE POUR SERRURE JT	2
212162	CONJ. CENTRADOR P/ FERRAGEM JT PERFIL LIG. CENTERING KIT FOR JT HARDWARE   KIT CENTRAGE POUR SERRURE JT	1
212371	CONJ. FIXAÇÃO JT FIXING KIT   KIT FIXATION	18
212017	CONJ. FIX. FERRAGEM MULTIP. MULTIPONT HARDWARE FIXING KIT   KIT FIXATION POUR SERRURE MULTIPONT	1 + 1 un./m (min. 4)
200819	PUXADOR SLIM XS - ESQUERDO LEFT HANDLE   POIGNÉE GAUCHE	1
200817	PUXADOR SLIM XS - DIREITO RIGHT HANDLE   POIGNÉE DROITE	2
200057	PUXADOR FOLHA PASSIVA SLIM XS PASSIVE SASH HANDLE   POIGNÉE VENTAIL PASSIVE	1
212384	CONJ. TOPOS LAT. PINGADEIRA JT82 LATERAL DRIP END-CAPS KIT   KIT D'EMBOUITS LATÉRAUX POUR REJET D'EAU	1
228107	LIMITADOR ABERT. PQ SERIE CORRER OPENING LIMITER   LIMITEUR D'OUVERTURE	2
290262	PARAFUSO PK INOX PH 1 1/2X10 CQ SCREW PK	32
218137	CALÇO REFORÇO HORIZONTAL JT * HORIZONTAL REINFORCEMENT SHIM   CALE DE RENFORCEMENT HORIZONTALE	8

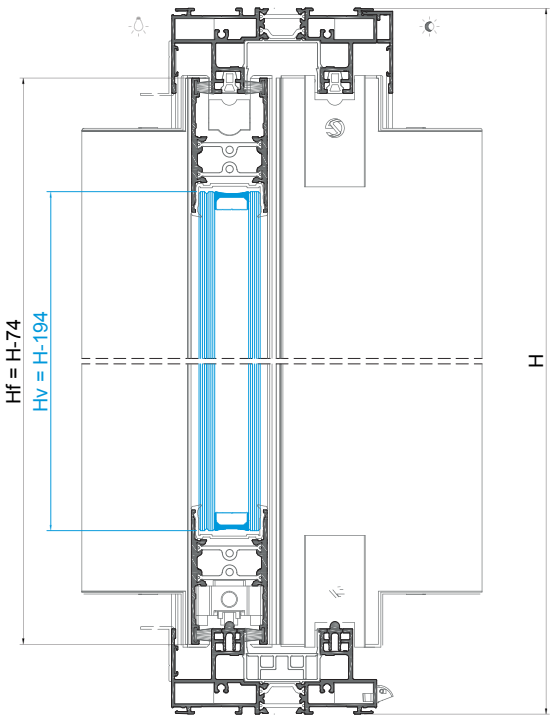

VEDANTES   SEALS   JOINTS		
CÓDIGO CODE   CODE	DESIGNAÇÃO DESIGNATION   NOMINATION	QUANT. QUANTITY QUANTITE
208348	JUNTA TAPA CANAL 2116 JT JOINT   JOINT	2L + 2H
208099	JUNTA VIDRO U 1032 CX 32MM JT GLAZING GASKET   JOINT DE VITRAGE	2L + 8H
208307	PELUCIA 7x10 TRI-FIN PRETA PILE SEAL   JOINT BRUSSE	4L + 14H
208479	JUNTA TAPA CANAL PERFIL LIG. 2117 JT JOINT   JOINT	H

\* Usar em folhas com vidros com peso superior a 80kg  
To be used in sashes which glass weight exceed 80kg | Utiliser dans des panneaux de verre d'un poids supérieur à 80 kg  
(a) Conforme esquemas de drenagem (Capítulo V - Maquinações)  
According to drainage schemes (Chapter V - Machinings) | Selon les schémas de drainage (Chapitre V - Usinages)

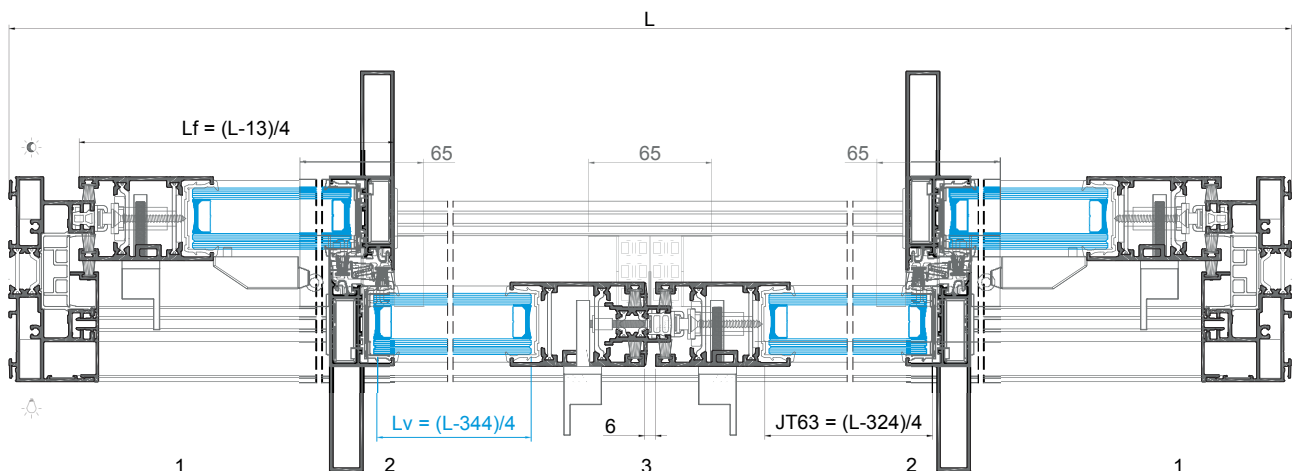



**JANELA DE CORRER 4 FOLHAS 2-RAIL CANTO 90° - LINHA PT**  
4 SASHES 2-RAIL SLIDING WINDOW 90° CORNER - PT LINE  
FENÊTRE COULISSANT 4 VANTAUX 2-RAIL À ANGLE 90° - LIGNE PT

PERFIS   PROFILES   PROFILÉS					
CÓDIGO CODE   CODE	DESIGNAÇÃO DESIGNATION   NOMINATION	CORTE HORIZ. HORIZONTAL CUT COUPE HORIZ.	CORTE VERT. VERTICAL CUT COUPE VERTICALE	QUANT. QUANTITY QUANTITE	CORTE CUT COUPE
JT 12	ARO FIXO FIXED FRAME   CADRE DORMANT	L1 L2	H	2 2 + 2	
JT 54	PERFIL CENTRAL CENTRAL PROFILE   PROFILÉ CENTRAL	-	H-74	4	
JT 67	PERFIL LATERAL LATERAL PROFILE   PROFILÉ LATÉRAL	-	H-74	2	
JT 62	PERFIL LATERAL CANTO 90° 90° CORNER LAT. PR. ITR. LAT. D'ANGLE À 90°	-	H-74	2	
JT 63	TRAVESSA SUP/INF UP/LOW TRANSOM   TRAVERSE SUP/INF	(L1-251)/2 (L2-263)/2	-	4 4	
JT 72	PERFIL LIGAÇÃO CANTO 90° CONNECTION PROFILE   PROFILÉ DE LIAISON	-	H-143	1	
JT 82	PERFIL PINGADEIRA Drip Profile   L'ARMIER	L1+19 L2+19	-	1 1	
JT 90	CAPA COVER   CAPOT	-	H-37	2	
JT 87	GUIA GUIDE   GUIDE	L1-48 L1-106 L2-48 L2-106	-	1 1 1 1	
208346	JUNTA CENTRAL 2196 CENTRAL JOINT   JOINT CENTRALE	-	H-74	4	
215305	PERFIL PVC U U PVC PROFILE   PROFILÉ PVC U	L1-34 L2-34	H-34	2 2 + 2	
215303	PERFIL PVC T T PVC PROFILE   PROFILÉ PVC T	(L1-117)/2 (L1-292)/2 (L2-130)/2 (L2-280)/2	H-37	1 1 1 + 2 1	

ACESSÓRIOS   ACCESSORIES   ACCESSOIRES			
CÓDIGO CODE   CODE	DESIGNAÇÃO DESIGNATION   NOMINATION	QUANT. QUANTITY QUANTITE	
205129	CARRINHO JT 180KG ROLLER   ROULETTE	8	
213286	CORTA-VENTO JT CENTRAL WATERPROOFING BRUSH   BROsse CENTRALE D'ÉTANCHÉITÉ	4	
213287	CORTA-VENTO CANTO 90° JT 90° CORNER WATERPROOFING BRUSH   BROsse D'ÉTANCHÉITÉ ANGLE 90°	2	
212337	CONJ. ESTANQ. CORTA-VENTO JT CENTRAL WATERPROOFING BRUSH KIT   KIT BROsse CENTRALE D'ÉTANCHÉITÉ	4	
204153	ESQUADRO JT 11x20.5 CORNER CLEAT   ÉQUERRE	8	
212243	CONJ. UNIÃO CANTO 90° JT 90° CORNER UNION KIT   KIT D'UNION ANGLE 90°	1	
204389	ESQUADRO INOX CANTO 90° 90° STAINLESS STEEL CORNER   ANGLE EN ACIER INOXYDABLE 90°	2	
213246	CANTO CR S/ SB CORNER   ANGLE	4	
212199	CONJ. TOPOS LAT. JT LATERAL END-CAPS KIT   KIT D'EMBOUITS LATÉRAUX	4	
212230	CONJ. TOPOS INTERIOR LAT. JT LATERAL INNER END-CAPS KIT   KIT D'EMBOUITS INTÉRIEUR LATÉRAUX	3	
212201	CONJ. TAMPAS TOPOS LAT. JT LATERAL END-CAPS KIT   KIT DE COUVERTURE POUR EMBOUTS LATÉRAUX	3	
212231	CONJ. TOPOS CENTRAIS JT CENTRAL END-CAPS KIT   KIT D'EMBOUITS CENTRAUX	4	
212339	CONJ. TAMPAS TOPOS CENTRAIS JT CENTRAL END-CAP COVERS KIT   KIT DE COUVERTURE POUR EMBOUTS CENTRAUX	4	
210243	TOPO CENTRAL REFORÇADO JT54 28MM 28MM CENTRAL END-CAPS KIT   KIT D'EMBOUITS CENTRAUX RENFORCÉ 28MM	8	
212109	CONJ. TOPOS CANTO 90° JT 90° CORNER END-CAPS KIT   KIT D'EMBOUITS POUR ANGLE 90°	1	
210268	GOTEIRA C/ VALV. SVE OUTSIDE FLAP VALVE   CLAPE À VOLET EXTÉRIEUR	(a)	
211223	FERRAGEM MULTIPONTO CENTR. 1000 MULTIPOINT HARDWARE   SERRURE MULTIPOINT	3	
202491	CONTRA-FECHO ANTI-LEVANTAMENTO MULTIPONTO STRIKING PLATE   GÂCHE	6	
202487	CENTRADOR JT P/ C-FECHO AL MULTIPONTO JT CENTERING FOR STRIKING PLATE   CENTRAGE JT POUR GÂCHE	4	
212455	CONJ. FIX. CONTRA-FECHO AL MULTIP. JT MULTIPOINT HARDWARE STRIKING PLATE FIXING KIT   KIT FIXATION GÂCHE SERRURE MULTIPOINT	4	
212458	CONJ. FIX. CONTRA-FECHO MULTIP. 2F/90° JT MULTIPOINT HARDWARE STRIKING PLATE FIXING KIT   KIT FIXATION GÂCHE SERRURE MULTIP.	2	
218154	CALÇO P/ C-FECHO PERF. LIG CONNECTING PROFILE STRIKING PLATE SHIM   CALE POUR GÂCHE PROFILÉ DE LIAISON	2	
218198	CALÇO P/ MULTIPONTO SOS JT MULTIPOINT HARDWARE SHIM   CALE POUR MULTIPOINT	18	
212161	CONJ. CENTRADOR P/ FERRAGEM JT CENTERING KIT FOR JT HARDWARE   KIT CENTRAGE POUR SERRURE JT	2	
212162	CONJ. CENTRADOR P/ FERRAGEM JT PERFIL LIG. CENTERING KIT FOR JT HARDWARE   KIT CENTRAGE POUR SERRURE JT	1	
212371	CONJ. FIXAÇÃO JT FIXING KIT   KIT FIXATION	18	
212079	CONJ. FIX. FERRAGEM MULTIP. JT72 MULTIPOINT FIXING KIT   KIT FIXATION SERRURE MULTIPOINT	1 + 1 un./m (min. 4m)	
200819	PUXADOR SLIM XS - ESQUERDO LEFT HANDLE   POIGNÉE GAUCHE	1	
200817	PUXADOR SLIM XS - DIREITO RIGHT HANDLE   POIGNÉE DROITE	2	
212384	CONJ. TOPOS LAT. PINGADEIRA JT82 LATERAL DRIP END-CAPS KIT   KIT D'EMBOUITS LATÉRAUX POUR REJET D'EAU	1	
228107	LIMITADOR ABERT. PQ SERIE CORRER OPENING LIMITER   LIMITEUR D'OUVERTURE	2	
290262	PARAFUSO PK INOX PH 1 1/2x10 CQ SCREW   VIS	32	
218137	CALÇO REFORÇO HORIZONTAL JT * HORIZONTAL REINFORCEMENT SHIM   CALE DE RENFORCEMENT HORIZONTALE	8	

\* Usar em folhas com vidros com peso superior a 80kg  
To be used in sashes which glass weight exceed 80kg | Utiliser dans des panneaux de verre d'un poids supérieur à 80 kg

(a) Conforme esquemas de drenagem (Capítulo V - Maquinações)  
According to drainage schemes (Chapter V - Machinings) | Selon les schémas de drainage (Chapitre V - Usinages)

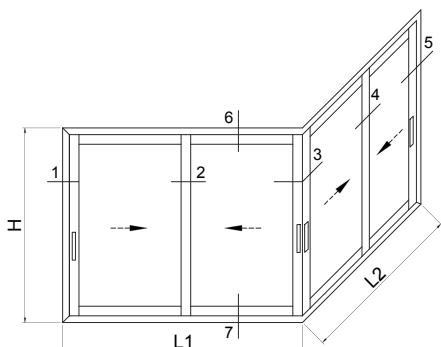

VEDANTES   SEALS   JOINTS		
CÓDIGO CODE   CODE	DESIGNAÇÃO DESIGNATION   NOMINATION	QUANT. QUANTITY QUANTITE
208348	JUNTA TAPA CANAL 2116 JT JOINT   JOINT	2L1 + 2H
208099	JUNTA VIDRO U 1032 CX 32MM JT GLAZING GASKET   JOINT DE VITRAGE	2L1 + 8H 2L2 + 8H
208307	PELUCIA 7x10 TRI-FIN PRETA PILE SEAL   JOINT BRUSSE	4L1 + 15H 4L2 + 15H
208479	JUNTA TAPA CANAL PERFIL LIG. 2117 JT JOINT   JOINT	H
208435	JUNTA VD 2415 JOINT   JOINT	H

As fórmulas foram concebidas para medidas de vidros iguais. Nesta tipologia existem 4 larguras de folha distintas: Lf1, Lf2, Lf3 e Lf4.  
The formulas were designed for glasses with equal measures. In this typology there are 4 distinct sash widths: Lf1, Lf2, Lf3 and Lf4.  
Les formules sont conçues pour mesurer le verre. Dans cette typologie, il existe 4 largeurs de vantaux distinctes: Lf1, Lf2, Lf3 et Lf4.

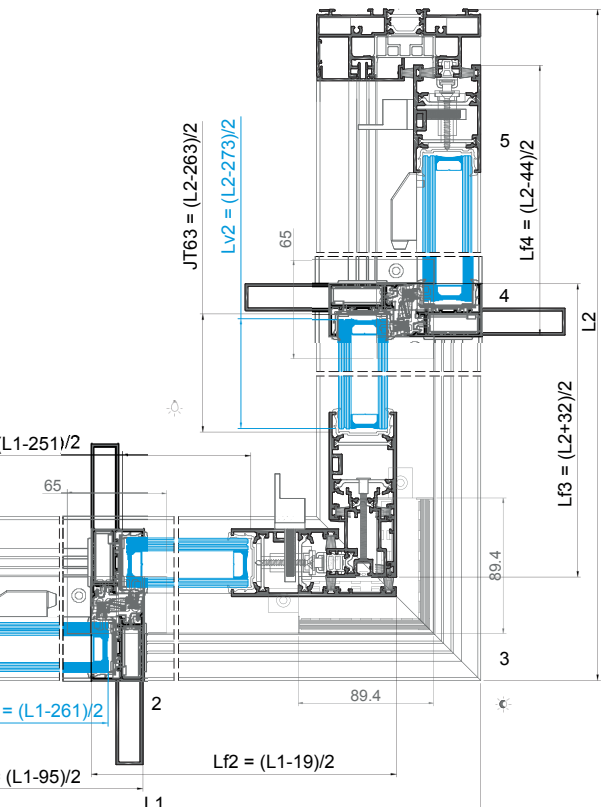
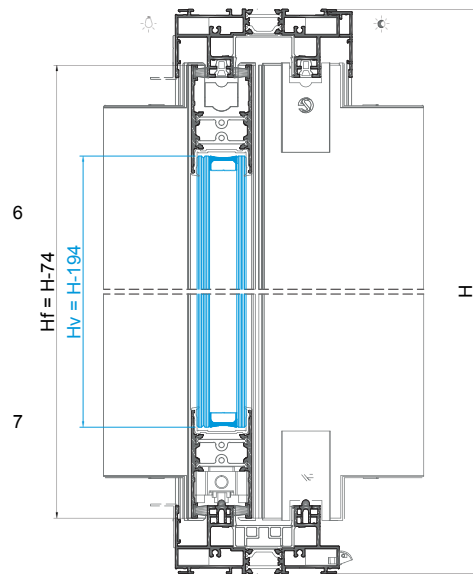



**JANELA DE CORRER 3 FOLHAS 3-RAIL - LINHA PT**  
3 SASHES 3-RAIL SLIDING WINDOW - PT LINE  
FENÊTRE COULISSANT 3 VANTAUX 3-RAIL - LIGNE PT

PERFIS   PROFILES   PROFILÉS					
CÓDIGO CODE   CODE	DESIGNAÇÃO DESIGNATION   NOMINATION	CORTE HORIZ. HORIZONTAL CUT COUPE HORIZ.	CORTE VERT. VERTICAL CUT COUPE VERTICALE	QUANT. QUANTITY QUANTITE	CORTE CUT COUPE
JT 13	ARO FIXO FIXED FRAME   CADRE DORMANT	L	H	2 + 2	
JT 54	PERFIL CENTRAL CENTRAL PROFILE   PROFILÉ CENTRAL	-	H-74	4	
JT 67	PERFIL LATERAL LATERAL PROFILE   PROFILÉ LATÉRAL	-	H-74	2	
JT 63	TRAVESSA SUP/INF UP/LW TRANSOM   TRAVERSE SUP/INF	(L-202)/3 (L-200)/3	-	4 2	
JT 82	PERFIL PINGADEIRA DRIP PROFILE   LARMIER	L-4	-	1	
JT 90	CAPA COVER   CAPOT	-	H-37	1	
JT 91	CAPA COVER   CAPOT	-	H-51	2	
JT 92	CAPA COVER   CAPOT	-	H-37	1	
JT 87	GUIA GUIDE   GUIDE	L-93 L-96	-	2 1	
208346	JUNTA CENTRAL 2196 CENTRAL JOINT   JOINT CENTRALE	-	H-74	4	
215305	PERFIL PVC U PVC PROFILE   PROFILÉ PVC U	L-34	H-34	4 + 4	
215303	PERFIL PVC T T PVC PROFILE   PROFILÉ PVC T	(L-103)/3 (2L-285)/3	H-37	2 + 4	

ACESSÓRIOS   ACCESSORIES   ACCESSOIRES		
CÓDIGO CODE   CODE	DESIGNAÇÃO DESIGNATION   NOMINATION	QUANT. QUANTITY QUANTITE
205129	CARRINHO JT 180KG ROLLER   ROULETTE	6
213286	CORTA-VENTO JT CENTRAL WATERPROOFING BRUSH   BROSSE CENTRALE D'TANCHÉITÉ	4
212337	CONJ. ESTANQ. CORTA-VENTO JT CENTRAL WATERPROOFING BRUSH KIT   KIT BROSSE CENTRALE D'TANCHÉITÉ	2
204153	ESQUADRO JT 11x20.5 CORNER CLEAT   ÉQUERRE	8
213246	CANTO CR S/SB CORNER   ANGLE	4
212199	CONJ. TOPOS LAT. JT LATERAL END-CAPS KIT   KIT D'EMBOUS LATÉRAUX	2
212230	CONJ. TOPOS INTERIOR LAT. JT LATERAL INNER END-CAPS KIT   KIT D'EMBOUS INTÉRIEUR LATÉRAUX	2
212201	CONJ. TAMPAS TOPOS LAT. JT LATERAL END-CAP COVERS KIT   KIT DE COUVERTURE POUR EMBOUTS LATÉRAUX	2
212231	CONJ. TOPOS CENTRAIS JT CENTRAL END-CAPS KIT   KIT D'EMBOUS CENTRAUX	4
212339	CONJ. TAMPAS TOPOS CENTRAIS JT CENTRAL END-CAP COVERS KIT   KIT DE COUVERTURE POUR EMBOUTS CENTRAUX	4
210243	TOPO CENTRAL REFORÇADO JT54 28MM 28MM CENTRAL REINFORCED END-CAPS KIT   KIT D'EMBOUS CENTRAUX RENFORCÉ 28MM	8
210268	GOTEIRA C/ VALV. SVE OUTSIDE FLAP VALVE   CLAPE À VOLET EXTÉRIEUR	(a)
211223	FERRAGEM MULTIPONTO CENTR. 1000 MULTIPOINT HARDWARE   SERRURE MULTIPONT	2
202491	CONTRA-FECHO ANTI-ELEVANTAMENTO MULTIPONTO STRIKING PLATE   GÂCHE	4
202487	CENTRADOR JT P/ C-FECHO AL MULTIPONTO JT CENTERING FOR STRIKING PLATE   CENTRAGE JT POUR GÂCHE	4
212455	CONJ. FIX. CONTRA-FECHO AL MULTIP. JT MULTIPOINT HARDWARE STRIKING PLATE FIXING KIT   KIT FIXATION GÂCHE SERRURE MULTIPONT	4
218198	CALÇO P/ MULTIPONTO SOS JT MULTIPOINT HARDWARE SHIM   CALE POUR MULTIPONT	2
212161	CONJ. CENTRADOR P/ FERRAGEM JT CENTERING KIT FOR JT HARDWARE   KIT CENTRAGE POUR SERRURE JT	12
212371	CONJ. FIXAÇÃO JT FIXING KIT   KIT FIXATION	12
200819	PUXADOR SLIM XS - ESQUERDO LEFT HANDLE   POIGNÉE GAUCHE	1
200817	PUXADOR SLIM XS - DIREITO RIGHT HANDLE   POIGNÉE DROITE	1
212384	CONJ. TOPOS LAT. PINGADEIRA JT82 LATERAL DRIP END-CAPS KIT   KIT D'EMBOUS LATÉRAUX POUR REJET D'EAU	1
228107	LIMITADOR ABERT. PQ SERIE CORRER OPENING LIMITER   LIMITEUR D'OUVERTURE	1
290262	PARAFUSO PK INOX PH 1/2X10 CQ SCREW   VIS	24
218137	CALÇO REFORÇO HORIZONTAL JT * HORIZONTAL REINFORCEMENT SHIM   CALE DE RENFORCEMENT HORIZONTALE	6

\* Usar em folhas com vidros com peso superior a 80kg  
To be used in sashes with glass weight exceed 80kg | Utiliser dans des panneaux de verre d'un poids supérieur à 80 kg  
(a) Conforme esquemas de drenagem (Capítulo V - Maquinações)  
According to drainage schemes (Chapter V - Usinages) | Selon les schémas de drainage (Chapitre V - Usinages)

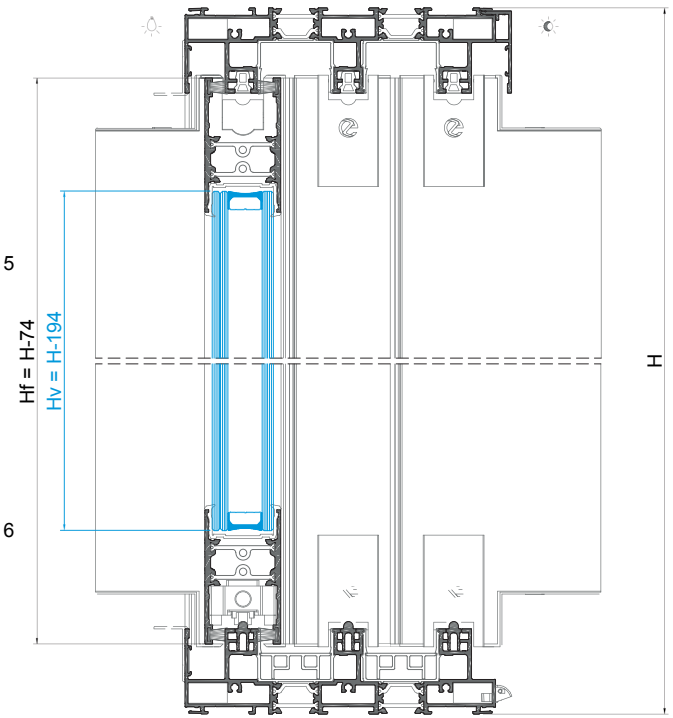
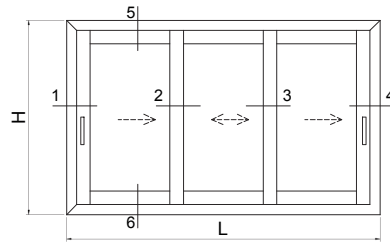

VEDANTES   SEALS   JOINTS		
CÓDIGO CODE   CODE	DESIGNAÇÃO DESIGNATION   NOMINATION	QUANT. QUANTITY QUANTITE
208348	JUNTA TAPA CANAL 2116 JT JOINT   JOINT	3L + 2H
208099	JUNTA VIDRO U 1032 CX 32MM JT GLAZING GASKET   JOINT DE VITRAGE	2L + 6H
208307	PELUCIA 7x10 TRI-FIN PRETA PILE SEAL   JOINT BROUSSE	4L + 10H

As fórmulas foram concebidas para medidas de vidros iguais.  
Nesta tipologia existem 2 larguras de folha distintas: Lf1 e Lf2.  
The formulas were designed for glasses with equal measures. In  
this typology there are 2 distinct sash widths: Lf1 and Lf2.  
Les formules sont conçues pour mesurer le verre. Dans cette  
typologie, il existe 2 largeurs de vantaux distinctes: Lf1 et Lf2.

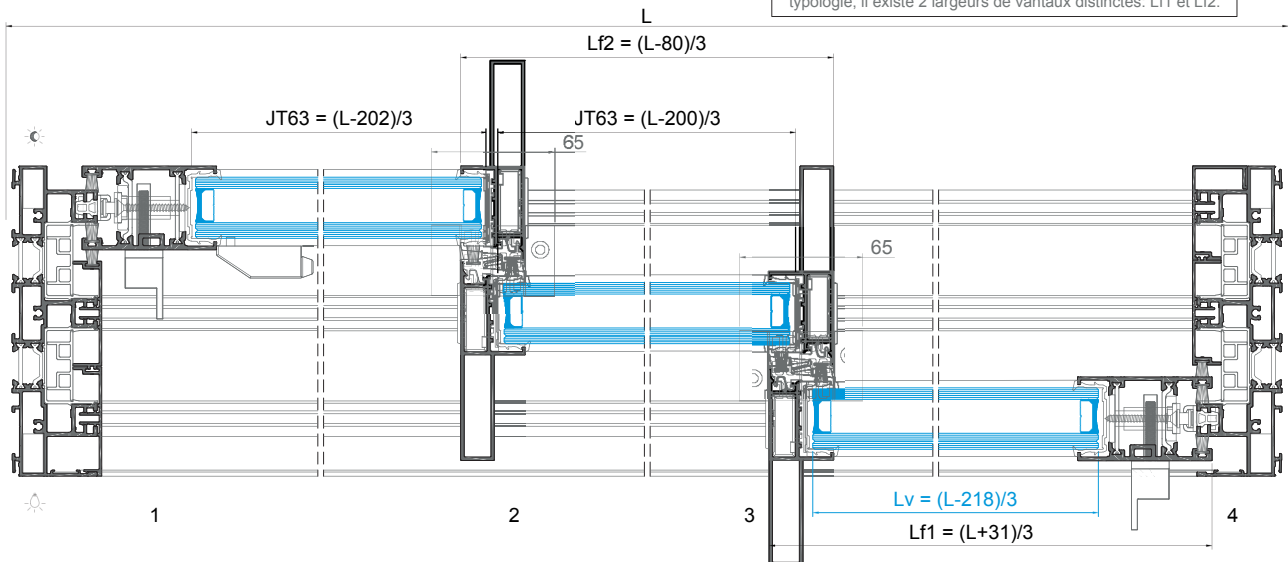

**JANELA DE CORRER 6 FOLHAS 3-RAIL COM LIGAÇÃO CENTRAL - LINHA PT**  
6 SASHES 3-RAIL SLIDING WINDOW WITH CENTRAL CONNECTION - PT LINE  
FENÊTRE COULISSANT 6 VANTAUX 3-RAIL AVEC CONNEXION CENTRALE - LIGNE PT

PERFIS   PROFILES   PROFILÉS					
CÓDIGO CODE   CODE	DESIGNAÇÃO DESIGNATION   NOMINATION	CORTE HORIZ. HORIZONTAL CUT COUPE HORIZ.	CORTE VERT. VERTICAL CUT COUPE VERTICALE	QUANT. QUANTITY QUANTITE	CORTE CUT COUPE
JT 13	ARO FIXO FIXED FRAME   CADRE DORMANT	L	H	2 + 2	
JT 54	PERFIL CENTRAL CENTRAL PROFILE   PROFILÉ CENTRAL	-	H-74	8	
JT 67	PERFIL LATERAL LATERAL PROFILE   PROFILÉ LATÉRAL	-	H-74	4	
JT 63	TRAVESSA SUP/INF UP/DOWN TRANSOM   TRAVERSE SUP/INF	(L-336)/6 (L-332)/6	-	8 4	
JT 71	PERFIL LIGAÇÃO CENTRAL CONNECTION PROFILE   PROFILÉ DE LIAISON	-	H-143	1	
JT 90	CAPA COVER   CAPOT	-	H-37	2	
JT 91	CAPA COVER   CAPOT	-	H-51	2	
JT 87	GUIA GUIDE   GUIDE	L-96 L-90	-	1 1	
JT 82	PERFIL PINGADEIRA DRIP PROFILE   LARMIER	L-4	-	1	
208346	JUNTA CENTRAL 2196 CENTRAL JOINT   JOINT CENTRALE	-	H-74	8	
215305	PERFIL PVC U U PVC PROFILE   PROFILÉ PVC U	L-34	H-34	4 + 4	
215303	PERFIL PVC T T PVC PROFILE   PROFILÉ PVC T	(L-137)/6 (2L-445)/3 (L-217)/3 (L-344)/6	-	2 1 2 2	

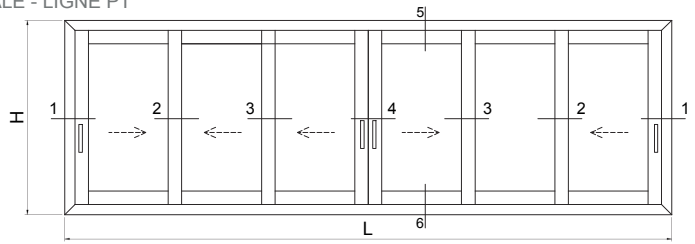

ACESSÓRIOS   ACCESSORIES   ACCESSOIRES		
CÓDIGO CODE   CODE	DESIGNAÇÃO DESIGNATION   NOMINATION	QUANT. QUANTITY QUANTITE
205129	CARRINHO JT 180KG ROLLER   ROULETTE	12
213286	CORTA-VENTO JT CENTRAL WATERPROOFING BRUSH   BROSSE CENTRALE D'ETANCHEITÉ	10
212337	CONJ. ESTANQ. CORTA-VENTO JT CENTRAL WATERPROOFING BRUSH KIT   KIT BROSSE CENTRALE D'ETANCHEITÉ	5
204153	ESQUADRO JT 11x20,5 CORNER CLEAT   ÉQUERRE	8
213246	CANTO CR S/SB CORNER ANGLE   ÉQUERRE	8
212199	CONJ. TOPOS LAT. JT LATERAL END-CAPS KIT   KIT D'EMBOUITS LATÉRAUX	4
212230	CONJ. TOPOS INTERIOR LAT. JT LATERAL INNER END-CAPS KIT   KIT D'EMBOUITS INTÉRIEUR LATÉRAUX	3
212201	CONJ. TAMPAS TOPOS LAT. JT LATERAL END-CAP COVERS KIT   KIT DE COUVERTURE POUR EMBOUTS LATÉRAUX	3
212231	CONJ. TOPOS CENTRAIS JT CENTRAL END-CAPS KIT   KIT D'EMBOUITS CENTRAUX	8
212339	CONJ. TAMPAS TOPOS CENTRAIS JT CENTRAL END-CAP COVERS KIT   KIT DE COUVERTURE POUR EMBOUTS CENTRAUX	8
210243	TOPO CENTRAL REFORÇADO JT54 28MM 28MM CENTRAL REINFORCED END-CAPS KIT   KIT D'EMBOUITS CENTRAUX RENFORCÉ 28MM	12
212104	CONJ. TOPOS LIG. 2 FOLHAS JT 2 SASHES END-CAPS KIT   KIT D'EMBOUITS CONNEXION 2 VANTAUX	1
210268	GOTEIRA C/ VALV. SVE OUTSIDE FLAP VALVE   CLAPE À VOLET EXTÉRIEUR	(a)
211223	FERRAGEM MULTIPONTO CENTR. 1000 MULTIPOINT HARDWARE   SERRURE MULTIPOINT	3
202491	CONTRA-FECHO ANTI-LEVANTAMENTO MULTIPONTO STRIKING PLATE   GÂCHE	6
202487	CENTRADOR JT P/ C-FECHO AL MULTIPONTO JT CENTERING FOR STRIKING PLATE   CENTRAGE JT POUR GÂCHE	4
212455	CONJ. FIX. CONTRA-FECHO AL MULTIP. JT MULTIPOINT HARDWARE STRIKING PLATE FIXING KIT   KIT FIXATION GÂCHE SERRURE MULTIPOINT	4
212458	CONJ. FIX. CONTRA-FECHO MULTIP. 2F/90° JT MULTIPOINT HARDWARE STRIKING PLATE FIXING KIT   KIT FIXATION GÂCHE SERRURE MULTIP.	2
218154	CALÇO P/ C-FECHO PERF. LIG CONNECTING PROFILE STRIKING PLATE SHIM   CALE POUR GÂCHE PROFILÉ DE LIAISON	2
218198	CALÇO P/ MULTIPONTO SOS JT MULTIPOINT HARDWARE SHIM   CALE POUR MULTIPOINT	18
212161	CONJ. CENTRADOR P/ FERRAGEM JT CENTERING KIT FOR JT HARDWARE   KIT CENTRAGE POUR SERRURE JT	2
212162	CONJ. CENTRADOR P/ FERRAGEM JT PERFIL LIG. CENTERING KIT FOR JT HARDWARE   KIT CENTRAGE POUR SERRURE JT	1
212371	CONJ. FIXAÇÃO JT FIXING KIT   KIT FIXATION	18
212017	CONJ. FIX. FERRAGEM MULTIP. MULTIPOINT HARDWARE FIXING KIT   KIT FIXATION POUR SERRURE MULTIPOINT	1 + 1 un./m (min. 4)
200819	PUXADOR SLIM XS - ESQUERDO LEFT HANDLE   POIGNÉE GAUCHE	1
200817	PUXADOR SLIM XS - DIREITO RIGHT HANDLE   POIGNÉE DROITE	2
200057	PUXADOR FOLHA PASSIVA SLIM XS PASSIVE SASH HANDLE   POIGNÉE VENTAL PASSIVE	1
212384	CONJ. TOPOS LAT. PINGADEIRA JT82 LATERAL DRIP END-CAPS KIT   KIT D'EMBOUITS LATÉRAUX POUR REJET D'EAU	1
228107	LIMITADOR ABERT. PQ SERIE CORRER OPENING LIMITER   LIMITER D'OUVERTURE	2
290262	PARAFUSO PK INOX PH 1 1/2X10 CQ SCREW   VIS	48
218137	CALÇO REFORÇO HORIZONTAL JT * HORIZONTAL REINFORCEMENT SHIM   CALE DE RENFORCEMENT HORIZONTALE	12

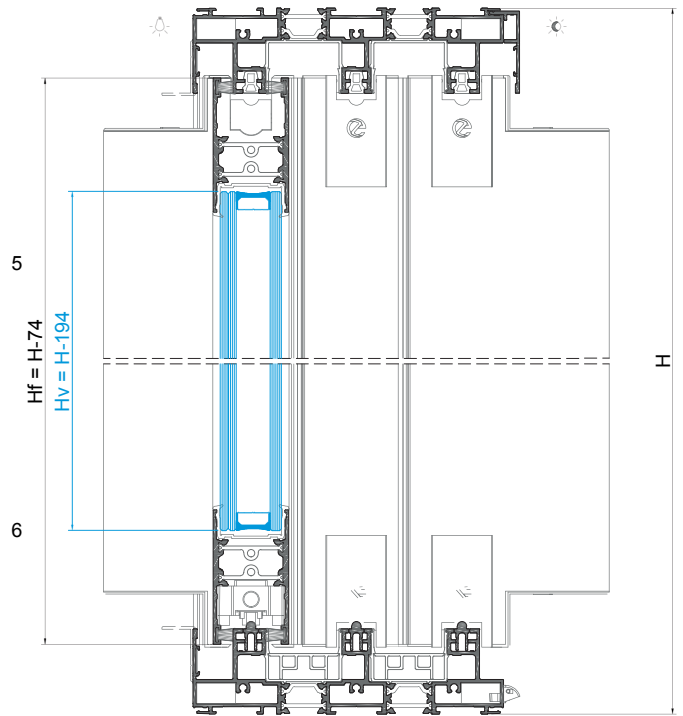

VEDANTES   SEALS   JOINTS		
CÓDIGO CODE   CODE	DESIGNAÇÃO DESIGNATION   NOMINATION	QUANT. QUANTITY QUANTITE
208348	JUNTA TAPA CANAL 2116 JT JOINT   JOINT	3L + 2H
208099	JUNTA VIDRO U 1032 CX 32MM JT GLAZING GASKET   JOINT DE VITRAGE	2L + 12H
208307	PELUCIA 7x10 TRI-FIN PRETA PILE SEAL   JOINT BROSSE	4L + 18H
208479	JUNTA TAPA CANAL PERFIL LIG. 2117 JT JOINT   JOINT	H

\* Usar em folhas com vidros com peso superior a 80kg  
To be used in sashes which glass weight exceed 80kg | Utiliser dans des panneaux de verre d'un poids supérieur à 80 kg  
(a) Conforme esquemas de drenagem (Capítulo V - Maquinagens) | Selon les schémas de drainage (Chapitre V - Usinages)

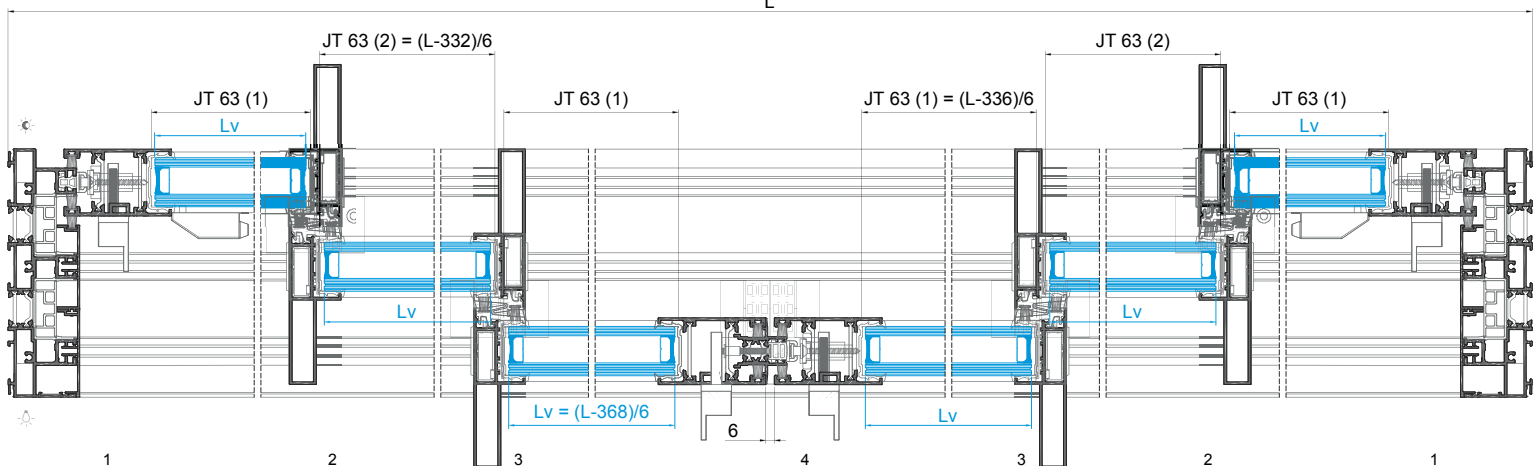

**JANELA DE CORRER 4 FOLHAS 4-RAIL - LINHA PT**  
4 SASHES 4-RAIL SLIDING WINDOW - PT LINE  
FENÊTRE COULISSANT 4 VANTAUX 4-RAIL - LIGNE PT

PERFIS   PROFILES   PROFILÉS					
CÓDIGO CODE / CODE	DESIGNAÇÃO DESIGNATION / NOMINATION	CORTE HORIZ. HORIZONTAL CUT COUPE HORIZ.	CORTE VERT. VERTICAL CUT COUPE VERTICALE	QUANT. QUANTITY QUANTITE	CORTE CUT COUPE
JT 33	ARO FIXO FIXED FRAME   CADRE DORMANT	L	H	2 + 2	
JT 54	PERFIL CENTRAL CENTRAL PROFILE   PROFILÉ CENTRAL	-	H-74	6	
JT 64	PERFIL LATERAL LATERAL PROFILE   PROFILÉ LATÉRAL	-	H-74	1	
JT 65	PERFIL LATERAL LATERAL PROFILE   PROFILÉ LATÉRAL	-	H-74	1	
JT 63	TRAVESSA SUP/INF UP/LOW TRANSOM   TRAVERSE SUP/INF	(L-209)/4 (L-206)/4	-	4 4	
JT 82	PERFIL PINGADEIRA DRIP PROFILE   L'ARMIER	L-4	-	1	
JT 90	CAPA COVER   CAPOT	-	H-37	1	
JT 91	CAPA COVER   CAPOT	-	H-51	4	
JT 92	CAPA COVER   CAPOT	-	H-37	1	
JT 87	GUIA GUIDE   GUIDE	L-93 L-96	-	2 2	
208346	JUNTA CENTRAL 2196 CENTRAL JOINT   JOINT CENTRALE	-	H-74	6	
215305	PERFIL PVC U U PVC PROFILE   PROFILÉ PVC U	L-34	H-34	6 + 6	
215303	PERFIL PVC T T PVC PROFILE   PROFILÉ PVC T	(L-76)/4 (L-129)/2 (3L-440)/4	H-37	2 + 6 2	

ACESSÓRIOS   ACCESSORIES   ACCESSOIRES			
CÓDIGO CODE / CODE	DESIGNAÇÃO DESIGNATION / NOMINATION	QUANT. QUANTITY QUANTITE	
205129	CARRINHO JT 180KG ROLLER / ROULETTE	8	
213286	CORTA-VENTO JT CENTRAL WATERPROOFING BRUSH   BROSSSE CENTRALE D'ETANCHÉITE	6	
212337	CONJ. ESTANQ. CORTA-VENTO JT CENTRAL WATERPROOFING BRUSH KIT   KIT BROSSSE CENTRALE D'ETANCHÉITE	3	
204153	ESQUADRO JT 11x20,5 CORNER GLEAT   EQUERRE	8	
213246	CANTO CR S/SSB CORNER   ANGLE	4	
212199	CONJ. TOPOS LAT. JT LATERAL END-CAPS KIT   KIT D'EMBOUTS LATÉRAUX	2	
212230	CONJ. TOPOS INTERIOR LAT. JT LATERAL INNER END-CAPS KIT   KIT D'EMBOUTS INTÉRIEUR LATÉRAUX	2	
212201	CONJ. TAMPAS TOPOS LAT. JT LATERAL END-CAP COVERS KIT   KIT DE COUVERTURE POUR EMBOUTS LATÉRAUX	2	
210239	TOPO JT64/JT65 28MM 28MM JT64/JT65 END-CAP   EMBOUT JT64/JT65 28MM	6	
212231	CONJ. TOPOS CENTRAIS JT CENTRAL END-CAPS KIT   KIT D'EMBOUTS CENTRAUX	6	
212339	CONJ. TAMPAS TOPOS CENTRAIS JT CENTRAL END-CAP COVERS KIT   KIT DE COUVERTURE POUR EMBOUTS CENTRAUX	6	
210243	TOPO CENTRAL REFORÇADO JT54 28MM 28MM CENTRAL REINFORCED END-CAPS KIT   KIT D'EMBOUTS CENTRAUX RENFORCÉ 28MM	12	
210268	GOTEIRA C/ VALV. S/VE OUTSIDE FLAP VALVE   CLAPE À VOLET EXTERIEUR	(a)	
211237	FERRAGEM MULTIPONTO ALU MAE.1000 (2P) MULTIPOINT HARDWARE   SERRURE MULTIPOINT	2	
202330	CONTRA-FECHO ALU STRIKING PLATE	4	
212455	CONJ. FIX. CONTRA-FECHO AL MULTIP. JT MULTIPOINT HARDWARE STRIKING PLATE FIXING KIT   KIT FIXATION GÂCHE SERRURE MULTIPOINT	4	
212289	CONJ. CENTRADOR P/ FERRAGEM ALU CENTERING KIT FOR ALU HARDWARE   KIT CENTRAGE POUR SERRURE ALU	2	
212371	CONJ. FIXAÇÃO JT FIXING KIT   KIT FIXATION	8	
201382	FECHO DE EMBUTIR R2051IX BUILT-IN HANDLE   POIGNÉE INTÉGRÉE	2	
204716	GANCHO LIG. MULTIPONTO GMB MULTIPOINT CONNECTION HOOK   CROCHET DE CONNEXION MULTIPOINT	2	
212384	CONJ. TOPOS LAT. PINGADEIRA JT82 LATERAL DRIP END-CAPS KIT   KIT D'EMBOUTS LATÉRAUX POUR REJET D'EAU	1	
228107	LIMITADOR ABERT. PQ SERIE CORRER OPENING LIMITER   LIMITEUR D'OUVERTURE	2	
290262	PARAFUSO PK INOX PH 1 1/2X10 CQ SCREW   IVS	32	
218137	CALÇO REFORÇO HORIZONTAL JT * HORIZONTAL REINFORCEMENT SHIM   CALE DE RENFORCEMENT HORIZONTALE	8	

\* Usar em folhas com vidros com peso superior a 80kg  
To be used in sashes which glass weight exceed 80kg | Utiliser dans des panneaux de verre d'un poids supérieur à 80 kg  
(a) Conforme esquemas de drenagem (Capítulo V - Maquinações)  
According to drainage schemes (Chapter V - Usinages) | Selon les schémas de drainage (Chapitre V - Usinages)

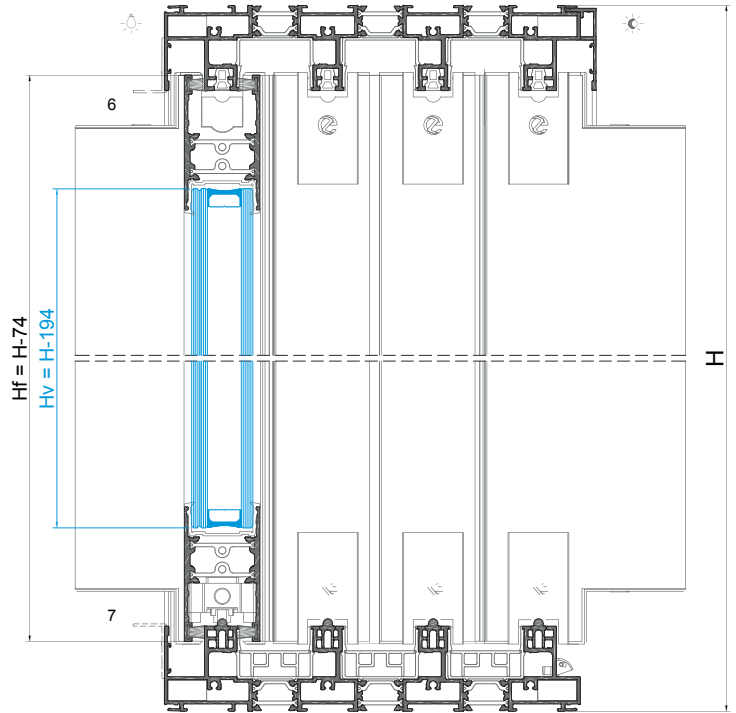
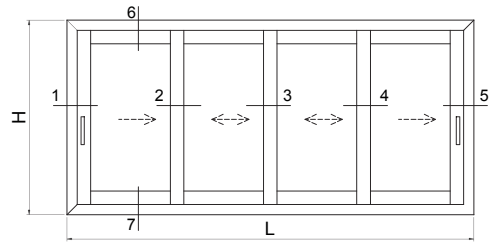

VEDANTES   SEALS   JOINTS		
CÓDIGO CODE / CODE	DESIGNAÇÃO DESIGNATION / NOMINATION	QUANT. QUANTITY QUANTITE
208348	JUNTA TAPA CANAL 2116 JT JOINT   JOINT	4L + 2H
208099	JUNTA VIDRO U 1032 CX 32MM JT GLAZING GASKET   JOINT DE VITRAGE	2L + 8H
208307	PELUCIA 7x10 TRI-FIN PRETA PILE SEAL   JOINT BROSSSE	4L + 12H

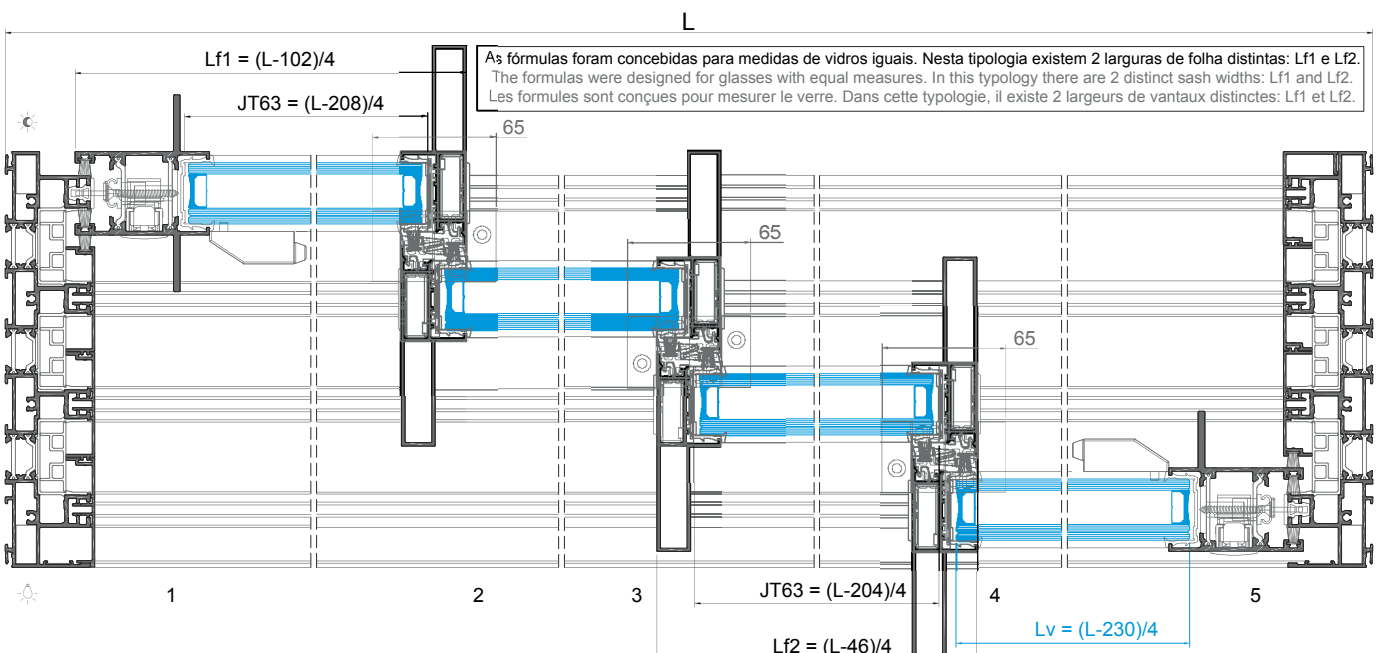

**JANELA DE CORRER 1 FOLHA DE EMBUTIR 2-RAIL - LINHA PT**  
1 SASH POCKET 2-RAIL SLIDING WINDOW - PT LINE  
FENÊTRE COULISSANT 1 VANTAIL À GALANDAGE 2-RAIL - LIGNE PT

PERFIS   PROFILES   PROFILÉS					
CÓDIGO CODE   CODE	DESIGNAÇÃO DESIGNATION   NOMINATION	CORTE HORIZ. HORIZONTAL CUT COUPE HORIZ.	CORTE VERT. VERTICAL CUT COUPE VERTICALE	QUANT. QUANTITY QUANTITÉ	CORTE CUT COUPE
JT 12	ARO FIXO FIXED FRAME   CADRE DORMANT	2L-24	H	2 + 2	
JT 51	PERFIL CENTRAL CENTRAL PROFILE   PROFILÉ CENTRAL	-	H-74	1	
JT 67	PERFIL LATERAL LATERAL PROFILE   PROFILÉ LATÉRAL	-	H-74	1	
JT 63	TRAVESSA SUP/INF UP/DOWN TRANSOM   TRAVERSE SUP/INF	L-81	-	2	
JT 92	CAPA COVER   CAPOT	L-19	H-37	2 + 1	
JT 87	GUIA GUIDE   GUIDE	2L-114	-	1	
JT 93	PERFIL MONTANTE MULLION PROFILE   PROFILÉ DE MENEAU	-	H-38	1	
SO 46	PERFIL REMATE FINISHING PROFILE   PROFILÉ DE FINITION	-	H-90	1	
SO 47	PERFIL REMATE FINISHING PROFILE   PROFILÉ DE FINITION	-	H-90	1	
SO 48	PERFIL REMATE FINISHING PROFILE   PROFILÉ DE FINITION	L+84	H+10	2 + 1	
KE 71	PERFIL REMATE FINISHING PROFILE   PROFILÉ DE FINITION	L-23	-	1	
KE 60	PERFIL REMATE FINISHING PROFILE   PROFILÉ DE FINITION	2L+36 L+6	H+60	1 + 2	
208346	JUNTA CENTRAL 2196 CENTRAL JOINT   JOINT CENTRALE	-	H-74	2	
215305	PERFIL PVC U UP PROFILE   PROFILÉ PVC U	2L-58	H-34	2 + 2	
215303	PERFIL PVC T T PVC PROFILE   PROFILÉ PVC T	L-92 L-34	H-37	1 + 1	

VEDANTES   SEALS   JOINTS		
CÓDIGO CODE   CODE	DESIGNAÇÃO DESIGNATION   NOMINATION	QUANT. QUANTITY QUANTITÉ
208348	JUNTA TAPA CANAL 2116 JT JOINT   JOINT	1L + 3H
208099	JUNTA VIDRO U 1032 CX 32MM JT GLAZING GASKET   JOINT DE VITRAGE	2L + 2H
208307	PELUCIA 7x10 TRI-FIN PRETA PILE SEAL   JOINT BRUSSE	6L + 5H
208466	PELUCIA 7x12 STOP-FIN PRETA PILE SEAL   JOINT BRUSSE	H

ACESSÓRIOS   ACCESSORIES   ACCESSOIRES		
CÓDIGO CODE   CODE	DESIGNAÇÃO DESIGNATION   NOMINATION	QUANT. QUANTITY QUANTITÉ
205129	CARRINHO JT 180KG ROLLER   ROULETTE	2
213286	CORTA-VENTO JT CENTRAL WATERPROOFING BRUSH   BRUSSE CENTRALE D'ÉTANCHÉITÉ	2
212337	CONJ. ESTANO. CORTA-VENTO JT CENTRAL WATERPROOFING BRUSH KIT   KIT BRUSSE CENTRALE D'ÉTANCHÉITÉ	1
204153	ESQUADRO JT 11x20.5 CORNER   ÉCART ÉQUERRE	8
213246	CANTO CR S/SB CORNER   ANGLE	7
212199	CONJ. TOPOS LAT. JT LATERAL END-CAPS KIT   KIT D'EMBOUS LATÉRAUX	1
212230	CONJ. TOPOS INTERIOR LAT. JT LATERAL INNER END-CAPS KIT   KIT D'EMBOUS INTÉRIEUR LATÉRAUX	1
212201	CONJ. TAMPAS TOPOS LAT. JT LATERAL END-CAP COVERS KIT   KIT DE COUVERTURE POUR EMBOUS LATÉRAUX	1
212231	CONJ. TOPOS CENTRAIS JT CENTRAL END-CAPS KIT   KIT D'EMBOUS CENTRAUX	1
212339	CONJ. TAMPAS TOPOS CENTRAIS JT CENTRAL END-CAP COVERS KIT   KIT DE COUVERTURE POUR EMBOUS CENTRAUX	1
210268	GOTEIRA C/ VALV. SVE OUTSIDE FLAP VALVE   CLAPE À VOLET EXTÉRIEUR	(a)
211223	FERRAGEM MULTIPONTO CENTR. 1000 MULTIPOINT HARDWARE   SERRURE MULTIPONTO	1
202491	CONTRA-FECHO ANTI-LEVANTAMENTO MULTIPONTO STRIKING PLATE   GÂCHE	2
202487	CENTRADOR JT P/ C-FECHO AL MULTIPONTO JT CENTERING FOR STRIKING PLATE   CENTRAGE JT POUR GÂCHE	2
212455	CONJ. FIX. CONTRA-FECHO AL MULTIP. JT MULTIPOINT HARDWARE STRIKING PLATE FIXING KIT   KIT FIXATION GÂCHE SERRURE MULTIPONTO	2
218198	CALÇO P/ MULTIPONTO SOS JT MULTIPOINT HARDWARE SHIM   CALE POUR MULTIPONTO	6
212161	CONJ. CENTRADOR P/ FERRAGEM JT CENTERING KIT FOR JT HARDWARE   KIT CENTRAGE POUR SERRURE JT	1
212371	CONJ. FIXAÇÃO JT FIXING KIT   KIT FIXATION	6
200819	PUXADOR SLIM XS - ESQUERDO LEFT HANDLE   POIGNÉE GAUCHE	1
212085	CONJ. TOPOS JT93 JT93 END-CAPS KIT   KIT D'EMBOUS JT93	1
212221	CONJ. TAPA TOPOS KE71 KE71 END-CAPS KIT   KIT D'EMBOUS KE71	1
290262	PARAFUSO PK INOX PH 1 1/2X10 CQ SCREW   VIS	8
218137	CALÇO REFORÇO HORIZONTAL JT* HORIZONTAL REINFORCEMENT SHIM   CALE DE RENFORCEMENT HORIZONTALE	2

\* Usar em folhas com vidros com peso superior a 80kg  
To be used in sashes which glass weight exceed 80kg | Utiliser dans des panneaux de verre d'un poids supérieur à 80 kg  
(a) Conforme esquemas de drenagem (Capítulo V - Maquinações)  
According to drainage schemes (Chapter V - Machinings) | Selon les schémas de drainage (Chapitre V - Usinages)

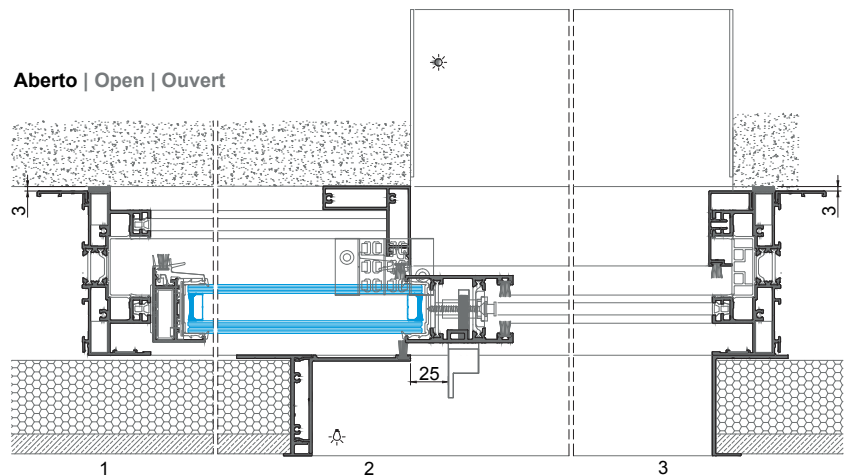
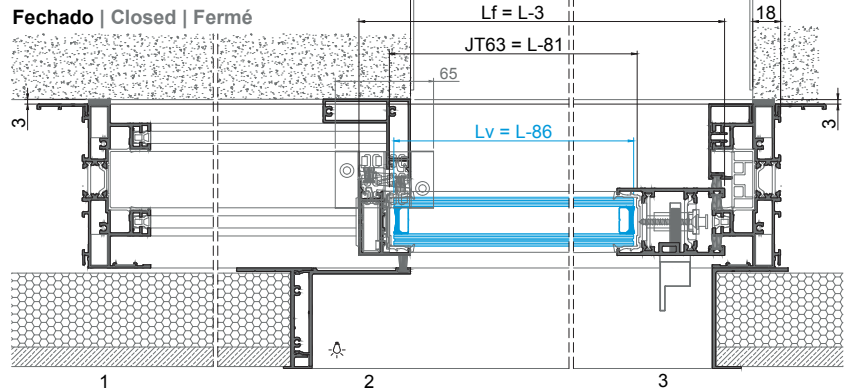
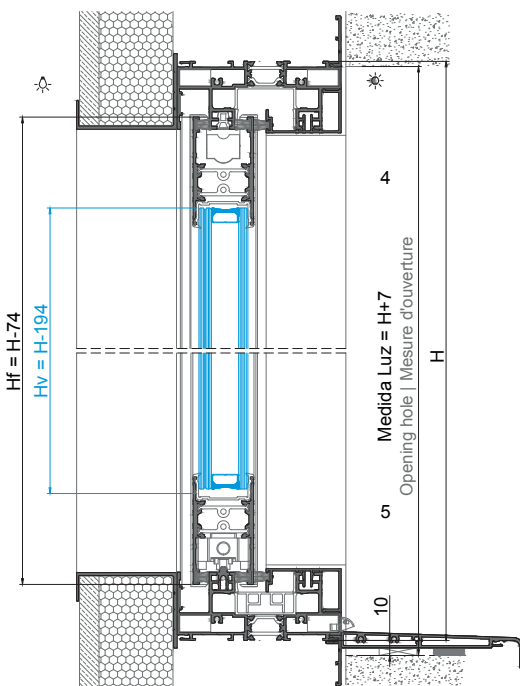
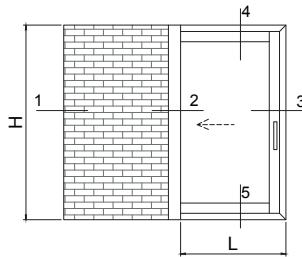



**JANELA DE CORRER 2 FOLHAS DE EMBUTIR 2-RAIL CANTO 90° - LINHA PT**  
2 SASHES POCKET 2-RAIL SLIDING WINDOW 90° CORNER - PT LINE  
FENÊTRE COULISSANT 2 VANTAUX À GALANDAGE 2-RAIL À ANGLE 90° - LIGNE PT

PERFIS   PROFILES   PROFILÉS					
CÓDIGO CODE	DESIGNAÇÃO DESIGNATION / NOMINATION	CORTE HORIZ. HORIZONTAL CUT COUPE HORIZ.	CORTE VERT. VERTICAL CUT COUPE VERTICALE	QUANT. QUANTITY QUANTITÉ	CORTE CUT COUPE
JT 12	ARO FIXO FIXED FRAME   CADRE DORMANT	2L1-80 2L2-94	H	2 2+2	
JT 51	PERFIL CENTRAL CENTRAL PROFILE   PROFILÉ CENTRAL	-	H-74	2	
JT 62	PERFIL LATERAL CANTO 90° 90° CORNER LAT. PR.   PR. LAT. D'ANGLE À 90°	-	H-74	2	
JT 63	TRAVESSA SUP/INF UP/LW TRANSOM   TRAVERSE SUP/INF	L1-138 L2-150	-	2	
JT 72	PERFIL LIGAÇÃO CANTO 90° CONNECTION PROFILE   PROFILÉ DE LIAISON	-	H-143	1	
JT 92	CAPA COVER   CAPOT	L1-1 L2-1	-	2	
JT 87	GUIA GUIDE	2L1-199 2L2-213	-	1	
JT 93	PERFIL MONTANTE MULLION PROFILE   PROFILÉ DE MENEAU	-	H-38	2	
SO 46	PERFIL REMATE FINISHING PROFILE   PROFILÉ DE FINITION	-	H-90	2	
SO 47	PERFIL REMATE FINISHING PROFILE   PROFILÉ DE FINITION	-	H-90	2	
SO 48	PERFIL REMATE FINISHING PROFILE   PROFILÉ DE FINITION	L1-29 L2-29	-	2	
KE 71	PERFIL REMATE FINISHING PROFILE   PROFILÉ DE FINITION	L1+118 L2+118	-	1	
KE 60	PERFIL REMATE FINISHING PROFILE   PROFILÉ DE FINITION	(2xL1)-158 L1-115 (2xL2)-173 L2-129	H+60	1 1+2 1 1	
208346	JUNTA CENTRAL 2196 CENTRAL JOINT   JOINT CENTRALE	-	H-74	4	
215305	PERFIL PVC U U PVC PROFILE   PROFILÉ PVC U	2L1-126 2L2-140	H-34	2 2+2	
215303	PERFIL PVC T T PVC PROFILE   PROFILÉ PVC T	L1-148 L1-133 L2-133 L2-162	-	1 1 1 1	

VEDANTES   SEALS   JOINTS		
CÓDIGO CODE	DESIGNAÇÃO DESIGNATION / NOMINATION	QUANT. QUANTITY QUANTITÉ
208348	JUNTA TAPA CANAL 2116 JT JOINT   JOINT	2L1+4H 2L2
208099	JUNTA VIDRO U 1032 CX 32MM JT GLAZING GASKET   JOINT DE VITRAGE	2L1+4H 2L2
208307	PELUCIA 7x10 TRI-FIN PRETA PILE SEAL   JOINT BROSSE	6L1 6L2+9H
208479	JUNTA TAPA CANAL PERFIL LIG. 2117 JT JOINT   JOINT	H
208435	JUNTA VD 2415 JOINT   JOINT	H
208466	PELUCIA 7x12 STOP-FIN PRETA PILE SEAL   JOINT BROSSE	2H

ACESSÓRIOS   ACCESSORIES   ACCESSOIRES		
CÓDIGO CODE	DESIGNAÇÃO DESIGNATION / NOMINATION	QUANT. QUANTITY QUANTITÉ
205129	CARRINHO JT 180KG ROLLER   ROULETTE	4
213286	CORTA-VENTO JT CENTRAL WATERPROOFING BRUSH   BROSSE CENTRALE D'ÉTANCHÉITÉ	4
213287	CORTA-VENTO CANTO 90° JT 90° CORNER WATERPROOFING BRUSH   BROSSE D'ÉTANCHÉITÉ ANGLE 90°	2
212337	CONJ. ESTANQ. CORTA-VENTO JT CENTRAL WATERPROOFING BRUSH KIT   KIT BROSSE CENTRALE D'ÉTANCHÉITÉ	4
204153	ESQUADRO JT 11x20,5 CORNER CLEAT   LEQUERRE	8
212243	CONJ. UNIÃO CANTO 90° JT 90° CORNER UNION KIT   KIT D'UNION ANGLE 90°	1
204389	ESQUADRO INOX CANTO 90° 90° CORNER END-CAPS KIT   KIT EN ACIER INOXYDABLE 90°	2
213246	CANTO CR S/SB CORNER   ANGLE	8
212199	CONJ. TOPOS LAT. JT LATERAL END-CAPS KIT   KIT D'EMBOUITS LATÉRAUX	2
212230	CONJ. TOPOS INTERIOR LAT. JT LATERAL INNER END-CAPS KIT   KIT D'EMBOUITS INTÉRIEUR LATÉRAUX	1
212201	CONJ. TAMPAS TOPOS LAT. JT CENTRAL END-CAP COVERS KIT   KIT DE COUVERTURE POUR EMBOUTS LATÉRAUX	1
212231	CONJ. TOPOS CENTRAIS JT CENTRAL END-CAPS KIT   KIT D'EMBOUITS CENTRAUX	2
212339	CONJ. TAMPAS TOPOS CENTRAIS JT CENTRAL END-CAP COVERS KIT   KIT DE COUVERTURE POUR EMBOUTS CENTRAUX	2
212109	CONJ. TOPOS CANTO 90° JT 90° CORNER END-CAPS KIT   KIT D'EMBOUITS POUR ANGLE 90°	1
210268	GOTEIRA C/ VALV. SVE OUTSIDE FLAP VALVE   CLAPE À VOLET EXTÉRIEUR	(a)
211223	FERRAGEM MULTIPONTO CENTR. 1000 MULTIPOINT HARDWARE   SERRURE MULTIPOINT	1
202491	CONTRA-FECHO ANTI-LEVANTAMENTO MULTIPONTO MULTIPOINT HARDWARE ANTI-STRIKING PLATE   GÂCHE SERRURE MULTIPOINT	2
212458	CONJ. FIX. CONTRA-FECHO MULTIP. 2F/90° JT MULTIPOINT HARDWARE STRIKING PLATE FIXING KIT   KIT FIXATION GÂCHE SERRURE MULTIP.	2
218154	CALÇO P/ C.-FECHO PERF. LIG CONNECTING PROFILE STRIKING PLATE SHIM   CALE POUR GÂCHE PROFILÉ DE LIAISON	2
218198	CALÇO P/ MULTIPONTO SOS JT MULTIPOINT HARDWARE SHIM   CALE POUR MULTIPONTO	6
212162	CONJ. CENTRADOR P/ FERRAGEM JT PERFIL LIG. CENTERING KIT FOR JT HARDWARE   KIT CENTRAGE POUR SERRURE JT	1
212371	CONJ. FIXAÇÃO JT FIXING KIT   KIT FIXATION	6
212079	CONJ. FIX. FERRAGEM MULTIP. JT72 MULTIPOINT FIXING KIT   KIT FIXATION SERRURE MULTIPOINT	1 + 1 un./m (min. 4)
200817	PUXADOR SLIM XS - DIREITO RIGHT HANDLE   POIGNEE DROITE	1
212085	CONJ. TOPOS JT93 JT93 END-CAPS KIT   KIT D'EMBOUITS JT93	2
212221	CONJ. TAPA TOPOS KE71 KE71 END-CAPS KIT   KIT D'EMBOUITS KE71	1
290262	PARAFUSO PK INOX PH 1 1/2X10 CQ SCREW   VIS	16
218137	CALÇO REFORÇO HORIZONTAL JT * HORIZONTAL REINFORCEMENT SHIM   CALE DE RENFORCEMENT HORIZONTALE	4

\* Usar em folhas com vidros com peso superior a 80kg  
To be used in sashes which glass weight exceed 80kg | Utiliser dans des panneaux de verre d'un poids supérieur à 80 kg  
(a) Conforme esquemas de drenagem (Capítulo V - Maquinações)  
According to drainage schemes (Chapter V - Machinings) | Selon les schémas de drainage (Chapitre V - Usinages)

As fórmulas foram concebidas para medidas de vidros iguais.  
Nesta tipologia existem 2 larguras de folha distintas: Lf1 e Lf2.  
The formulas were designed for glasses with equal measures.  
In this typology there are 2 distinct sash widths: Lf1 and Lf2.  
Les formules sont conçues pour mesurer le verre. Dans cette typologie, il existe 2 largeurs de vantaux distinctes: Lf1 et Lf2.

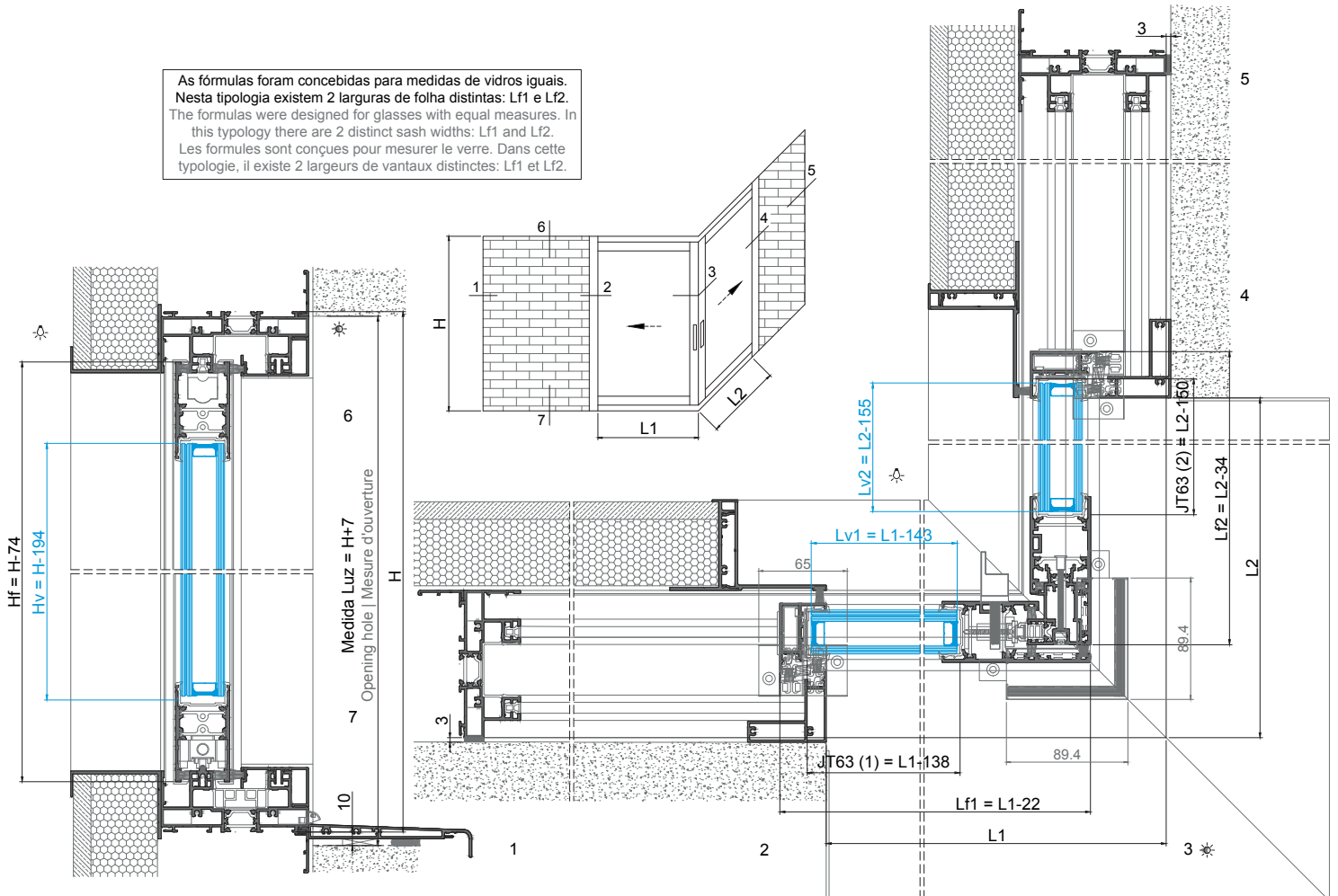

**JANELA DE CORRER 4 FOLHAS DE EMBUTIR 3-RAIL COM LIGAÇÃO CENTRAL - LINHA PT**  
4 SASHES POCKET 3-RAIL SLIDING WINDOW WITH CENTRAL CONNECTION - PT LINE  
FENÊTRE COULISSANT 4 VANTAUX À GALANDAGE 3-RAIL AVEC CONNEXION CENTRALE - LIGNE PT

PERFIS   PROFILES   PROFILÉS					
CÓDIGO CODE   CODE	DESIGNAÇÃO DESIGNATION   NOMINATION	CORTE HORIZ. HORIZONTAL CUT COUPE HORIZ.	CORTE VERT. VERTICAL CUT COUPE VERTICALE	QUANT. QUANTITY QUANTITE	CORTE CUT COUPE
JT 13	ARO FIXO FIXED FRAME   CADRE DORMANT	(3L+244)/2	H	2 + 2	
JT 51	PERFIL CENTRAL CENTRAL PROFILE   PROFILÉ CENTRAL	-	H-74	4	
JT 53	PERFIL CENTRAL CENTRAL PROFILE   PROFILÉ CENTRAL	-	H-74	2	
JT 67	PERFIL LATERAL LATERAL PROFILE   PROFILÉ LATÉRAL	-	H-74	2	
JT 63	TRAVESSA SUP/INF UP/LOW TRANSOM   TRAVERSE SUP/INF	(L-107)/4 (L-104)/4	-	4 4	
JT 71	PERFIL LIGAÇÃO CENTRAL CONNECTION PROFILE   PROFILÉ DE LIAISON	-	H-143	1	
JT 92	CAPA COVER   CAPOT	L-5	-	2	
JT 91	CAPA COVER   CAPOT	(L+71)/2	-	2	
JT 87	GUIA GUIDE   GUIDE	(3L+61)/2 (L-4)/2	-	1 2	
JT 93	PERFIL MONTANTE MULION PROFILE   PROFILÉ DE MENEAU	-	H-38	2	
SO 46	PERFIL REMATE FINISHING PROFILE   PROFILÉ DE FINITION	-	H-90	2	
SO 47	PERFIL REMATE FINISHING PROFILE   PROFILÉ DE FINITION	-	H-90	2	
SO 48	PERFIL REMATE FINISHING PROFILE   PROFILÉ DE FINITION	L+158	-	2	
KE 71	PERFIL REMATE FINISHING PROFILE   PROFILÉ DE FINITION	L-6	-	1	
KE 60	PERFIL REMATE FINISHING PROFILE   PROFILÉ DE FINITION	(3L+364)/2 (L-364)/4	H+60	1 2 + 2	
208346	JUNTA CENTRAL 2196 CENTRAL JOINT   JOINT CENTRALE	-	H-74	8	
215305	PERFIL PVC U U PVC PROFILE   PROFILÉ PVC U	(3L+175)/2	H-34	4 + 4	
215303	PERFIL PVC T T PVC PROFILE   PROFILÉ PVC T	(L-54)/2 (L-112)/4 (L-27)/4 L-31	-	2 2 2 1	

ACESSÓRIOS   ACCESSORIES   ACCESSOIRES		
CÓDIGO CODE   CODE	DESIGNAÇÃO DESIGNATION   NOMINATION	QUANT. QUANTITY QUANTITE
205129	CARRINHO JT 180KG ROLLER   ROULETTE	8
213286	CORTA-VENTO JT CENTRAL WATERPROOFING BRUSH   BROSSE CENTRALE D'ÉTANCHÉITÉ	10
212337	CONJ. ESTANQ. CORTA-VENTO JT CENTRAL WATERPROOFING BRUSH KIT   KIT BROSSE CENTRALE D'ÉTANCHÉITÉ	5
204153	ESQUADRO JT 11x20.5 CORNER GLEAT   ÉQUERRE	8
213246	CANTO CR S/SB CORNER   ANGLE	7
212199	CONJ. TOPOS LAT. JT LATERAL END-CAPS KIT   KIT D'EMBOUTS LATÉRAUX	2
212230	CONJ. TOPOS INTERIOR LAT. JT LATERAL INNER END-CAPS KIT   KIT D'EMBOUTS INTÉRIEUR LATÉRAUX	1
212201	CONJ. TAMPAS TOPOS LAT. JT LATERAL END-CAP COVERS KIT   KIT DE COUVERTURE POUR EMBOUTS LATÉRAUX	1
212231	CONJ. TOPOS CENTRAIS JT CENTRAL END-CAPS KIT   KIT D'EMBOUTS CENTRAUX	6
212339	CONJ. TAMPAS TOPOS CENTRAIS JT CENTRAL END-CAP COVERS KIT   KIT DE COUVERTURE POUR EMBOUTS CENTRAUX	6
210241	TOPO CENTRAL REFORÇADO 28MM 28MM CENTRAL REINFORCED END-CAPS KIT   KIT D'EMBOUTS CENTRAUX RENFORCÉ 28MM	4
212104	CONJ. TOPOS LIG. 2 FOLHAS JT 2 SASHES CONNECTING END-CAPS KIT   KIT D'EMBOUTS CONNEXION 2 VANTAUX	1
210268	GOTEIRA C/ VALV. SVE OUTSIDE FLAP VALVE   CLAPE À VOLET EXTÉRIEUR	(a)
211223	FERRAGEM MULTIPONTO CENTR. 1000 CONNECTING PROFILE STRIKING PLATE SHIM   CALE POUR GÂCHE PROFILÉ DE LIASION	1
202491	CONTRA-FECHO ANTI-LEVANTAMENTO MULTIPONTO STRIKING PLATE   GÂCHE	2
212458	CONJ. FIX. CONTRA-FECHO MULTIP. 2F/90° JT MULTIPONT HARDWARE STRIKING PLATE FIXING KIT   KIT FIXATION GÂCHE SERRURE MULTIP.	2
218154	CALÇO P/ C.-FECHO PERF. LIG HORIZONTAL REINFORCEMENT SHIM   CALE POUR GÂCHE PROFILÉ DE LIASION	2
218198	CALÇO P/ MULTIPONTO SOS JT MULTIPONT HARDWARE SHIM   CALE POUR MULTIPONT	6
212162	CONJ. CENTRADOR P/ FERRAGEM JT PERFIL LIG. CENTERING KIT FOR JT HARDWARE   KIT CENTRAGE POUR SERRURE JT	1
212371	CONJ. FIXAÇÃO JT FIXING KIT   KIT FIXATION	6
212017	CONJ. FIX. FERRAGEM MULTIP. MULTIPONT HARDWARE FIXING KIT   KIT FIXATION POUR SERRURE MULTIPONT	1 + 1 un./m (min. 4)
200817	PUXADOR SLIM XS - DIREITO RIGHT HANDLE   POIGNÉE DROITE	1
200057	PUXADOR FOLHA PASSIVA SLIM XS PASSIVE SASH HANDLE   POIGNÉE VENTAL PASSIVE	1
212085	CONJ. TOPOS JT93 JTS END-CAPS KIT   KIT D'EMBOUTS JT93	2
212221	CONJ. TAPA TOPOS KE71 KE71 END-CAPS KIT   KIT D'EMBOUTS KE71	1
290262	PARAFUSO PK INOX PH 1 1/2X10 CQ SCREW   VIS	32
218137	CALÇO REFORÇO HORIZONTAL JT * HORIZONTAL REINFORCEMENT SHIM   CALE DE RENFORCEMENT HORIZONTALE	8

\* Usar em folhas com vidros com peso superior a 80kg | Utiliser dans des panneaux de verre d'un poids supérieur à 80 kg  
(a) Conforme esquemas de drenagem (Capítulo V - Maquinações) | Selon les schémas de drainage (Chapitre V - Usinages)

VEDANTES   SEALS   JOINTS		
CÓDIGO CODE   CODE	DESIGNAÇÃO DESIGNATION   NOMINATION	QUANT. QUANTITY QUANTITE
208348	JUNTA TAPA CANAL 2116 JT JOINT   JOINT	2L + 6H
208099	JUNTA VIDRO U 1032 CX 32MM JT GLAZING GASKET   JOINT DE VITRAGE	2L + 8H
208307	PELUCIA 7x10 TRI-FIN PRETA PILE SEAL   JOINT BROSSE	10L + 12H
208466	PELUCIA 7x12 STOP-FIN PRETA PILE SEAL   JOINT BROSSE	2H

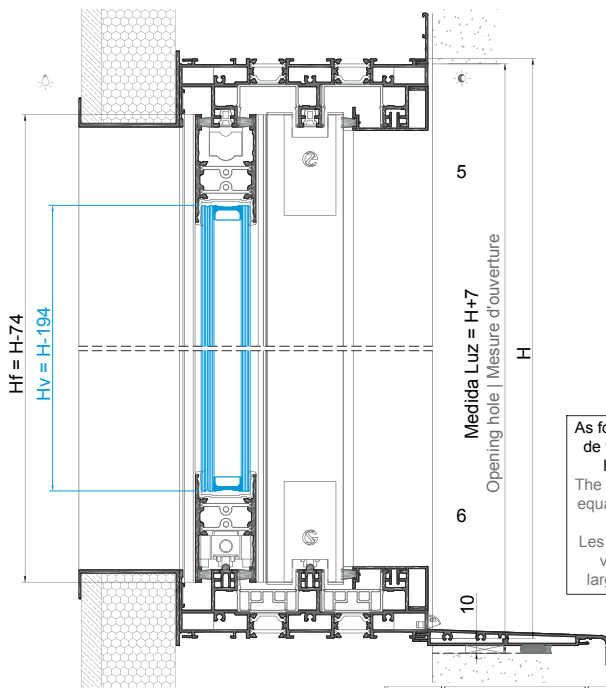

As fórmulas foram concebidas para medidas de vidros iguais. Nesta tipologia existem 2 larguras de folha distintas: Lf1 e Lf2.  
The formulas were designed for glasses with equal measures. In this typology there are 2 distinct sash widths: Lf1 and Lf2.  
Les formules sont conçues pour mesurer le verre. Dans cette typologie, il existe 2 largeurs de vantaux distinctes: Lf1 et Lf2.

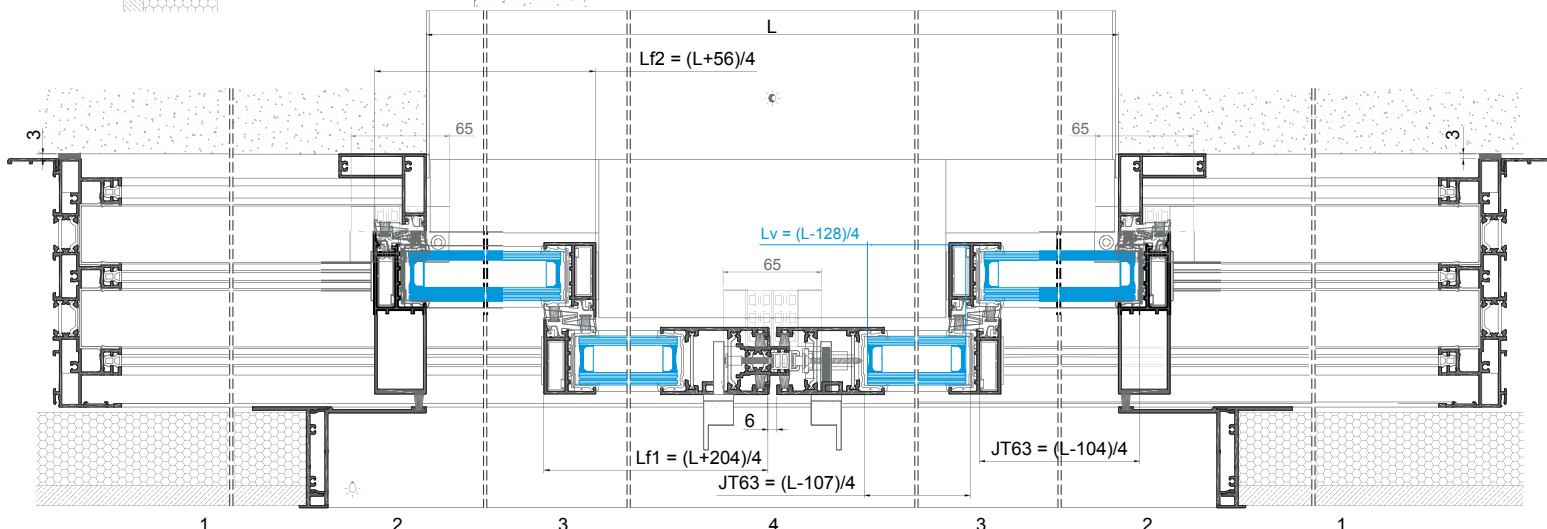
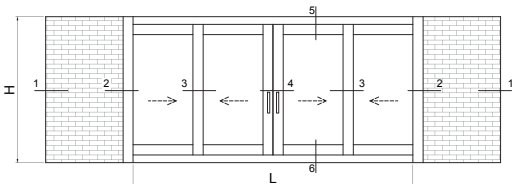

**JANELA DE CORRER 2 FOLHAS 2-RAIL COM OMBREIRA JT18 - LINHA SOLEIRA 30MM**  
2 SASHES 2-RAIL WITH JT18 JAMB SLIDING WINDOW - 30MM SILL LINE  
FENÊTRE COULISSANT 2 VANTAUX 2-RAIL AVEC JAMBAGE JT18 - LIGNE SEUIL 30MM

PERFIS   PROFILES   PROFILÉS					
CÓDIGO CODE   CODE	DESIGNAÇÃO DESIGNATION   NOMINATION	CORTE HORIZ. HORIZONTAL CUT COUPE HORIZ.	CORTE VERT. VERTICAL CUT COUPE VERTICALE	QUANT. QUANTITY QUANTITE	CORTE CUT COUPE
JT 12	PADEIRA LINTELA   LINTEAU	L-39	-	1	
JT 18	OMBREIRA JAMB   JAMBAGE	-	H	2	
JT 78	GUIA DA OMBREIRA JAMB GUIDE   GUIDE POUR JAMBAGE	-	H-74	2	
JT 22	SOLEIRA SILL   SEUIL	L-39	-	1	
JT 54	PERFIL CENTRAL CENTRAL PROFILE   PROFILÉ CENTRAL	-	H-59	2	
JT 67	PERFIL LATERAL LATERAL PROFILE   PROFILÉ LATÉRAL	-	H-59	2	
JT 63	TRAVESSA SUP/INF UP/DOWN TRANSOM   TRAVERSE SUP/INF	(L-169)/2	-	4	
JT 82	PERFIL PINGADEIRA DRIP PROFILE   L'ARMIER	L-4	-	1	
JT 87	GUIA GUIDE   GUIDE	L-51	-	2	
JE 96	PERFIL POLIAMIDA POLYAMIDE PROFILE   PROFILÉ DE POLYAMIDE	(L-74)/2	H	2 + 2	
208346	JUNTA CENTRAL 2198 CENTRAL JOINT   JOINT CENTRALE	-	H-59	2	
215305	PERFIL PVC U U PVC PROFILE   PROFILÉ PVC U	L-39	-	1	

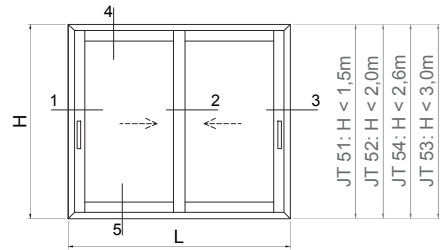

ACESSÓRIOS   ACCESSORIES   ACCESSOIRES		
CÓDIGO CODE   CODE	DESIGNAÇÃO DESIGNATION   NOMINATION	QUANT. QUANTITY QUANTITE
205129	CARRINHO JT 180KG ROLLER   ROULETTE	4
213286	CORTA-VENTO JT CENTRAL WATERPROOFING BRUSH   BROSSSE CENTRALE D'ETANCHÉITÉ	1
213288	CORTA-VENTO BAIXO JT LOW CENTRAL WATERPROOFING BRUSH   BROSSSE CENTRALE D'ETANCHÉITÉ BAS	1
223105	KIT JUNTAS ADESIVAS Nº1 JT JT Nº1 ADHESIVE JOINTS KIT   KIT DE JOINTS ADHÉSIFS Nº1 JT	1
212199	CONJ. TOPOS LAT. JT LATERAL END-CAPS KIT   KIT D'EMBOUITS LATÉRAUX	2
212230	CONJ. TOPOS INTERIOR LAT. JT LATERAL INNER END-CAPS KIT   KIT D'EMBOUITS INTÉRIEUR LATÉRAUX	2
212201	CONJ. TAMPAS TOPOS LAT. JT LATERAL END-CAP COVERS KIT   KIT DE COUVERTURE POUR EMBOUTS LATÉRAUX	2
212231	CONJ. TOPOS CENTRAIS JT CENTRAL END-CAPS KIT   KIT D'EMBOUITS CENTRAUX	2
212339	CONJ. TAMPAS TOPOS CENTRAIS JT CENTRAL END-CAP COVERS KIT   KIT DE COUVERTURE POUR EMBOUTS CENTRAUX	2
210243	TOPO CENTRAL REFORÇADO JT54 28MM 28MM CENTRAL REINFORCED END-CAPS KIT   KIT D'EMBOUITS CENTRAUX RENFORCÉ 28MM	4
210268	GOTEIRA C/ VALV. SVE OUTSIDE FLAP VALVE   CLAPE À VOLET EXTÉRIEUR	(a)
211223	FERRAGEM MULTIPONTO CENTR. 1000 MULTIPOINT HARDWARE   SERRURE MULTIPONTO	2
202491	CONTRA-FECHO ANTI-LEVANTAMENTO MULTIPONTO STRIKING PLATE   GÂCHE	4
202487	CENTRADOR JT P/ C-FECHO AL MULTIPONTO JT CENTERING FOR STRIKING PLATE   CENTRAGE JT POUR GÂCHE	4
212455	CONJ. FIX. CONTRA-FECHO AL MULTIP. JT MULTIPOINT HARDWARE STRIKING PLATE FIXING KIT   KIT FIXATION GÂCHE SERRURE MULTIPONTO	4
218198	CALÇO P/ MULTIPONTO SOS JT MULTIPOINT HARDWARE SHIM   CALE POUR MULTIPONTO	12
212161	CONJ. CENTRADOR P/ FERRAGEM JT CENTERING KIT FOR JT HARDWARE   KIT CENTRAGE POUR SERRURE JT	2
212371	CONJ. FIXAÇÃO JT FIXING KIT   KIT FIXATION	12
200819	PUXADOR SLIM XS - ESQUERDO LEFT HANDLE   POIGNÉE GAUCHE	1
200817	PUXADOR SLIM XS - DIREITO RIGHT HANDLE   POIGNÉE DROITE	1
212384	CONJ. TOPOS LAT. PINGADEIRA JT82 LATERAL DRIP END-CAPS KIT   KIT D'EMBOUITS LATÉRAUX POUR REJET D'EAU	1
228107	LIMITADOR ABERT. PQ SERIE CORRER OPENING LIMITER   LIMITEUR D'OUVERTURE	1
290052	PARAFUSO DIN7982 PH 3,5x16 A2 SCREW   VIS	1 + 4 un./m
290262	PARAFUSO PK INOX PH 1 1/2x10 CQ SCREW   VIS	16
290030	PARAFUSO DIN7981 4,2x38 INOX A2 SCREW   VIS	8
218137	CALÇO REFORÇO HORIZONTAL JT * HORIZONTAL REINFORCEMENT SHIM   CALE DE RENFORCEMENT HORIZONTALE	4

\* Usar em folhas com vidros com peso superior a 80kg  
To be used in sashes which glass weight exceed 80kg | Utiliser dans des panneaux de verre d'un poids supérieur à 80 kg  
(a) Conforme esquemas de drenagem (Capítulo V - Maquinações)  
According to drainage schemes (Chapter V - Machinings) | Selon les schémas de drainage (Chapitre V - Usinages)

VEDANTES   SEALS   JOINTS		
CÓDIGO CODE   CODE	DESIGNAÇÃO DESIGNATION   NOMINATION	QUANT. QUANTITY QUANTITE
208348	JUNTA TAPA CANAL 2116 JT JOINT   JOINT	2L + 2H
208099	JUNTA VIDRO U 1032 CX 32MM JT GLAZING GASKET   JOINT DE VITRAGE	2L + 4H
208307	PELUCIA 7x10 TRI-FIN PRETA PILE SEAL   JOINT BROUSSE	4L + 6H

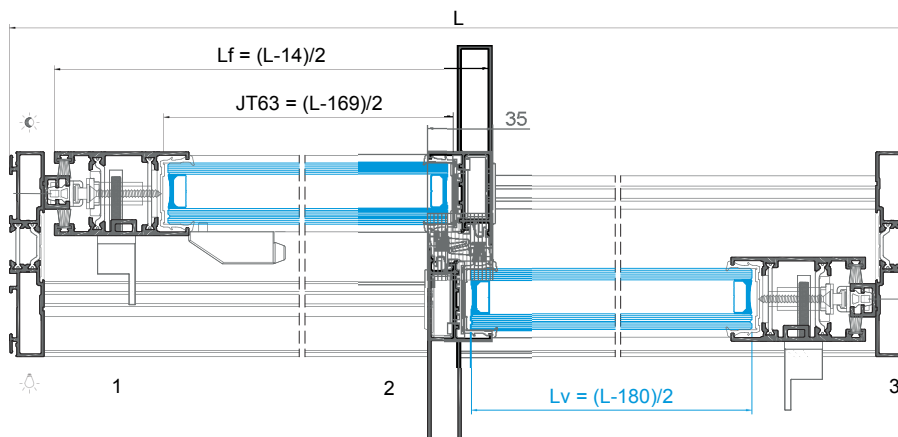
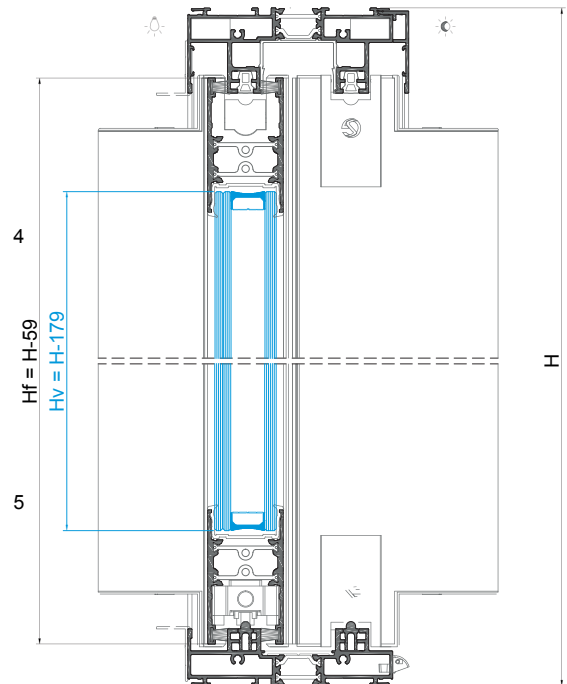

**JANELA DE CORRER 2 FOLHAS 2-RAIL COM OMBREIRAS JT17/JT19 - LINHA SOLEIRA 30MM**  
2 SASHES 2-RAIL WITH JT17/JT19 JAMB SLIDING WINDOW - 30MM SILL LINE  
FENÊTRE COULISSANT 2 VANTAUX 2-RAIL AVEC JAMBAGE JT17/19 - LIGNE SEUIL 30MM

PERFIS   PROFILES   PROFILÉS					
CÓDIGO CODE   CODE	DESIGNAÇÃO DESIGNATION   NOMINATION	CORTE HORIZ. HORIZONTAL CUT COUPE HORIZ.	CORTE VERT. VERTICAL CUT COUPE VERTICALE	QUANT. QUANTITY QUANTITE	CORTE CUT COUPE
JT 12	PADEIRA SILL   LINTEAU	L-39	-	1	
JT 17	OMBREIRA JAMB   JAMBAGE	-	H	1	
JT 19	OMBREIRA JAMB   JAMBAGE	-	H	1	
JT 22	SOLEIRA SILL   SEUIL	L-39	-	1	
JT 54	PERFIL CENTRAL CENTRAL PROFILE   PROFILÉ CENTRAL	-	H-59	2	
JT 67	PERFIL LATERAL LATERAL PROFILE   PROFILÉ LATÉRAL	-	H-59	2	
JT 63	TRAVESSA SUP/INF UP/DOWN TRANSOM   TRAVERSE SUP/INF	(L-166)/2	-	4	
JT 82	PERFIL PINGADEIRA DRIP PROFILE   L'ARMIER	L-4	-	1	
JT 87	GUIA GUIDE   GUIDE	L-49	-	2	
JE 96	PERFIL POLIAMIDA POLYAMIDE PROFILE   PROFILÉ DE POLYAMIDE	(L-74)/2	H	2 + 2	
208346	JUNTA CENTRAL 2196	-	H-59	2	
215305	PERFIL PVC U U PVC PROFILE   PROFILÉ PVC U	L-39	-	1	

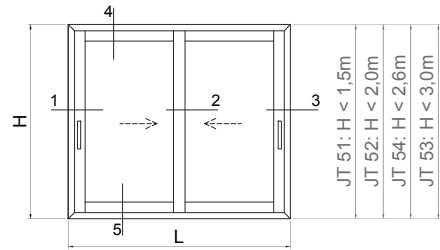

ACESSÓRIOS   ACCESSORIES   ACCESSOIRES		
CÓDIGO CODE   CODE	DESIGNAÇÃO DESIGNATION   NOMINATION	QUANT. QUANTITY QUANTITE
205129	CARRINHO JT 180KG ROLLER   ROULETTE	4
213286	CORTA-VENTO JT CENTRAL WATERPROOFING BRUSH   BROSSSE CENTRALE D'ETANCHÉITÉ	1
213288	CORTA-VENTO BAIXO JT LOW CENTRAL WATERPROOFING BRUSH   BROSSSE CENTRALE D'ETANCHÉITÉ BAS	1
223105	KIT JUNTAS ADESIVAS Nº1 JT JT Nº1 ADHESIVE JOINTS KIT   KIT DE JOINTS ADHÉSIFS Nº1 JT	1
212199	CONJ. TOPOS LAT. JT LATERAL END-CAPS KIT   KIT D'EMBOUITS LATÉRAUX	2
212230	CONJ. TOPOS INTERIOR LAT. JT LATERAL INNER END-CAPS KIT   KIT D'EMBOUITS INTÉRIEUR LATÉRAUX	2
212201	CONJ. TAMPAS TOPOS LAT. JT LATERAL END-CAP COVERS KIT   KIT DE COUVERTURE POUR EMBOUTS LATÉRAUX	2
212231	CONJ. TOPOS CENTRAIS JT CENTRAL END-CAPS KIT   KIT D'EMBOUITS CENTRAUX	2
212339	CONJ. TAMPAS TOPOS CENTRAIS JT CENTRAL END-CAP COVERS KIT   KIT DE COUVERTURE POUR EMBOUTS CENTRAUX	2
210243	TOPO CENTRAL REFORÇADO JT54 28MM 28MM CENTRAL REINFORCED END-CAPS KIT   KIT D'EMBOUITS CENTRAUX RENFORCÉ 28MM	4
210268	GOTEIRA C/ VALV. SVE OUTSIDE FLAP VALVE   CLAPE À VOLET EXTÉRIEUR	(a)
211223	FERRAGEM MULTIPONTO CENTR. 1000 MULTIPOINT HARDWARE   SERRURE MULTIPONTO	2
202491	CONTRA-FECHO ANTI-LEVANTAMENTO MULTIPONTO STRIKING PLATE   GÂCHE	4
202487	CENTRADOR JT P/ C-FECHO AL MULTIPONTO JT CENTERING FOR STRIKING PLATE   CENTRAGE JT POUR GÂCHE	4
212455	CONJ. FIX. CONTRA-FECHO AL MULTIP. JT MULTIPOINT HARDWARE STRIKING PLATE FIXING KIT   KIT FIXATION GÂCHE SERRURE MULTIPONTO	4
218198	CALÇO P/ MULTIPONTO SOS JT MULTIPOINT HARDWARE SHIM   CALE POUR MULTIPONTO	12
212161	CONJ. CENTRADOR P/ FERRAGEM JT CENTERING KIT FOR JT HARDWARE   KIT CENTRAGE POUR SERRURE JT	2
212371	CONJ. FIXAÇÃO JT FIXING KIT   KIT FIXATION	12
200819	PUXADOR SLIM XS - ESQUERDO LEFT HANDLE   POIGNÉE GAUCHE	1
200817	PUXADOR SLIM XS - DIREITO RIGHT HANDLE   POIGNÉE DROITE	1
212384	CONJ. TOPOS LAT. PINGADEIRA JT82 LATERAL DRIP END-CAPS KIT   KIT D'EMBOUITS LATÉRAUX POUR REJET D'EAU	1
228107	LIMITADOR ABERT. PQ SERIE CORRER OPENING LIMITER   LIMITEUR D'OUVERTURE	1
290262	PARAFUSO PK INOX PH 1 1/2X10 CQ SCREW   VIS	16
290030	PARAFUSO DIN7981 4,2x38 INOX A2 SCREW   VIS	8
218137	CALÇO REFORÇO HORIZONTAL JT * HORIZONTAL REINFORCEMENT SHIM   CALE DE RENFORCEMENT HORIZONTALE	4

\* Usar em folhas com vidros com peso superior a 80kg  
To be used in sashes which glass weight exceed 80kg | Utiliser dans des panneaux de verre d'un poids supérieur à 80 kg  
(a) Conforme esquemas de drenagem (Capítulo V - Maquinações)  
According to drainage schemes (Chapter V - Machinings) | Selon les schémas de drainage (Chapitre V - Usinages)

VEDANTES   SEALS   JOINTS		
CÓDIGO CODE   CODE	DESIGNAÇÃO DESIGNATION   NOMINATION	QUANT. QUANTITY QUANTITE
208348	JUNTA TAPA CANAL 2116 JT JOINT JOINT	2L + 2H
208099	JUNTA VIDRO U 1032 CX 32MM JT GLAZING GASKET   JOINT DE VITRAGE	2L + 4H
208307	PELUCIA 7x10 TRI-FIN PRETA PILE SEAL   JOINT BROSSE	4L + 6H

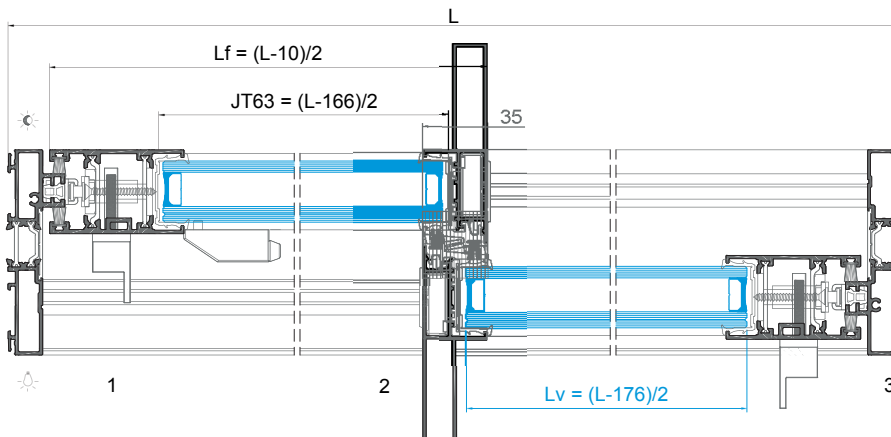
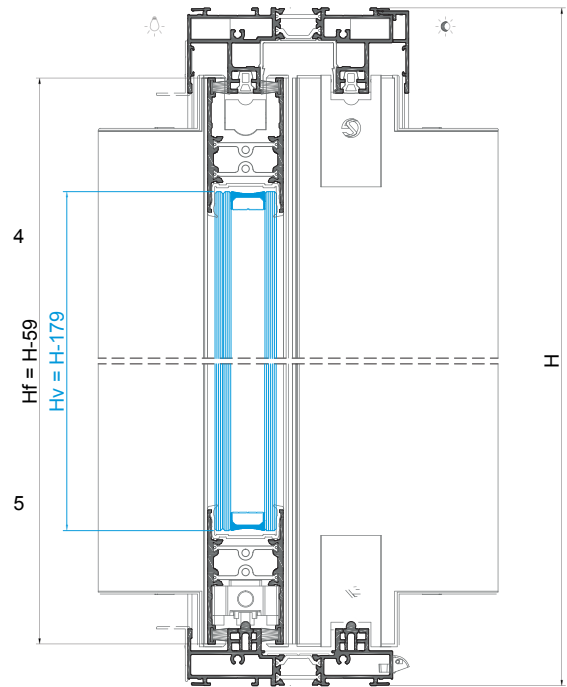



**JANELA DE CORRER 3 FOLHAS 2-RAIL COM OMBREIRA JT18 - LINHA SOLEIRA 30MM**  
3 SASHES 2-RAIL WITH JT18 JAMB SLIDING WINDOW - 30MM SILL LINE  
FENÊTRE COULISSANT 3 VANTAOX 2-RAIL AVEC JAMBAGE JT18 - LIGNE SEUIL 30MM

PERFIS   PROFILES   PROFILÉS					
CÓDIGO CODE   CODE	DESIGNAÇÃO DESIGNATION   NOMINATION	CORTE HORIZ. HORIZONTAL CUT COUPE HORIZ.	CORTE VERT. VERTICAL CUT COUPE VERTICALE	QUANT. QUANTITY QUANTITE	CORTE CUT COUPE
JT 12	PADEIRA JAMB   LINTEAU	L-39	-	1	
JT 18	OMBREIRA JAMB   JAMBAGE	-	H	2	
JT 78	GUIA DA OMBREIRA JAMB GUIDE   GUIDE POUR JAMBAGE	-	H-74	2	
JT 22	SOLEIRA SILL   SEUIL	L-39	-	1	
JT 54	PERFIL CENTRAL CENTRAL PROFILE   PROFILÉ CENTRAL	-	H-59	4	
JT 67	PERFIL LATERAL LATERAL PROFILE   PROFILÉ LATÉRAL	-	H-59	2	
JT 63	TRAVESSA SUP/INF UP/LW TRANSV. TRAVERSE SUP/INF	(L-175)/3 (L-173)/3	-	4 2	
JT 82	PERFIL PINGADEIRA DRIP PROFILE   L'ARMIER	L-4	-	1	
JT 87	GUIA GUIDE   GUIDE	L-65 L-38	-	1 1	
JE 96	PERFIL POLIAMIDA POLYAMIDE PROFILE   PROFILÉ DE POLYAMIDE	(L-33)/3 (L-261)/3	H	2 1 + 2	
208346	JUNTA CENTRAL 216 CENTRAL JOINT   JOINT CENTRALE	-	H-59	4	
215305	PERFIL PVC U U PVC PROFILE   PROFILÉ PVC U	L-39	-	1	

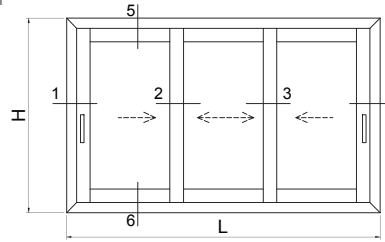

ACESSÓRIOS   ACCESSORIES   ACCESSOIRES		
CÓDIGO CODE   CODE	DESIGNAÇÃO DESIGNATION   NOMINATION	QUANT. QUANTITY QUANTITE
205129	CARRINHO JT 180KG ROLLER   ROULETTE	6
213286	CORTA-VENTO JT CENTRAL WATER-PROOFING BRUSH   Brosse centrale d'étanchéité	2
213288	CORTA-VENTO BAIXO JT LOW CENTRAL WATER-PROOFING BRUSH   Brosse centrale d'étanchéité bas	2
223105	KIT JUNTAS ADESIVAS Nº1 JT JT Nº1 ADHESIVE JOINTS KIT   KIT DE JOINTS ADHÉSIFS Nº1 JT	1
212199	CONJ. TOPOS LAT. JT LATERAL END-CAPS KIT   KIT D'EMBOUTS LATÉRAUX	2
212230	CONJ. TOPOS INTERIOR LAT. JT LATERAL INNER END-CAPS KIT   KIT D'EMBOUTS INTÉRIEUR LATÉRAUX	2
212201	CONJ. TAMPAS TOPOS LAT. JT LATERAL END-CAP COVERS KIT   KIT DE COUVERTURE POUR EMBOUTS LATÉRAUX	2
212231	CONJ. TOPOS CENTRAIS JT CENTRAL END-CAPS KIT   KIT D'EMBOUTS CENTRAUX	4
212339	CONJ. TAMPAS TOPOS CENTRAIS JT CENTRAL END-CAP COVERS KIT   KIT DE COUVERTURE POUR EMBOUTS CENTRAUX	4
210243	TOPO CENTRAL REFORÇADO JT54 28MM 28MM CENTRAL REINFORCED END-CAPS KIT   KIT D'EMBOUTS CENTRAUX REINFORCÉ 28MM	8
210268	GOTEIRA C/ VALV. SVE OUTSIDE FLAP VALVE   CLAPE À VOILET EXTERIEUR	(a)
211223	FERRAGEM MULTIPONTO CENTR. 1000 MULTIPOINT HARDWARE   SERRURE MULTIPONT	2
202491	CONTRA-FECHO ANTI-LEVANTAMENTO MULTIPONTO STRIKING GÂCHE	4
202487	CENTRADOR JT P/ C-FECHO AL MULTIPONTO JT CENTERING FOR STRIKING PLATE   CENTRAGE JT POUR GÂCHE	4
212455	CONJ. FIX. CONTRA-FECHO AL MULTIP. JT MULTIPOINT HARDWARE STRIKING PLATE FIXING KIT   KIT FIXATION GÂCHE SERRURE MULTIPONT	4
218198	CALÇO P/ MULTIPONTO SOS JT MULTIPOINT HARDWARE SHIM   CALE POUR MULTIPONT	12
212161	CONJ. CENTRADOR P/ FERRAGEM JT CENTERING KIT FOR JT HARDWARE   KIT CENTRAGE POUR SERRURE JT	2
212371	CONJ. FIXAÇÃO JT FIXING KIT   KIT FIXATION	12
200819	PUXADOR SLIM XS - ESQUERDO LEFT HANDLE   POIGNEE GAUCHE	1
200817	PUXADOR SLIM XS - DIREITO RIGHT HANDLE   POIGNEE DROITE	1
212384	CONJ. TOPOS LAT. PINGADEIRA JT82 LATERAL DRIP END-CAPS KIT   KIT D'EMBOUTS LATÉRAUX POUR REJET D'EAU	1
290052	PARAF. DIN7982 PH 3,5x16 A2 SCREW   VIS	1 + 4 un./m
290262	PARAFUSO PK INOX PH 1 1/2X10 CQ SCREW   VIS	24
290030	PARAFUSO DIN7981 4,2x38 INOX A2 SCREW   VIS	8
218137	CALÇO REFORÇO HORIZONTAL JT * HORIZONTAL REINFORCEMENT SHIM   CALE DE RENFORCEMENT HORIZONTALE	6

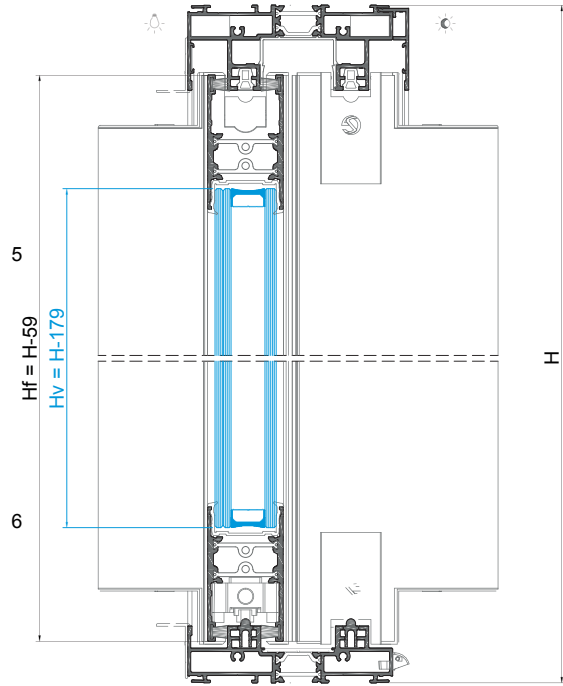

\* Usar em folhas com vidros com peso superior a 80kg  
To be used in sashes with glasses which glass weight exceed 80kg | Utiliser dans des panneaux de verre d'un poids supérieur à 80 kg  
(a) Conforme esquemas de drenagem (Capítulo V - Maquinações)  
According to drainage schemes (Chapter V - Machinings) | Selon les schémas de drainage (Chapitre V - Usinages)

VEDANTES   SEALS   JOINTS		
CÓDIGO CODE   CODE	DESIGNAÇÃO DESIGNATION   NOMINATION	QUANT. QUANTITY QUANTITE
208348	JUNTA TAPA CANAL 2116 JT JOINT   JOINT	2L + 2H
208099	JUNTA VIDRO U 1032 CX 32MM JT GLAZING GASKET   JOINT DE VITRAGE	2L + 6H
208307	PELUCIA 7x10 TRI-FIN PRETA PILE SEAL   JOINT BROUSSE	4L + 8H

As fórmulas foram concebidas para medidas de vidros iguais.  
Nesta tipologia existem 2 larguras de folha distintas: Lf1 e Lf2.  
The formulas were designed for glasses with equal measures. In this tipologia there are 2 distinct sash widths: Lf1 and Lf2.  
Les formules sont conçues pour mesurer le verre. Dans cette tipologia, il existe 2 largeurs de vantaux distinctes: Lf1 et Lf2.

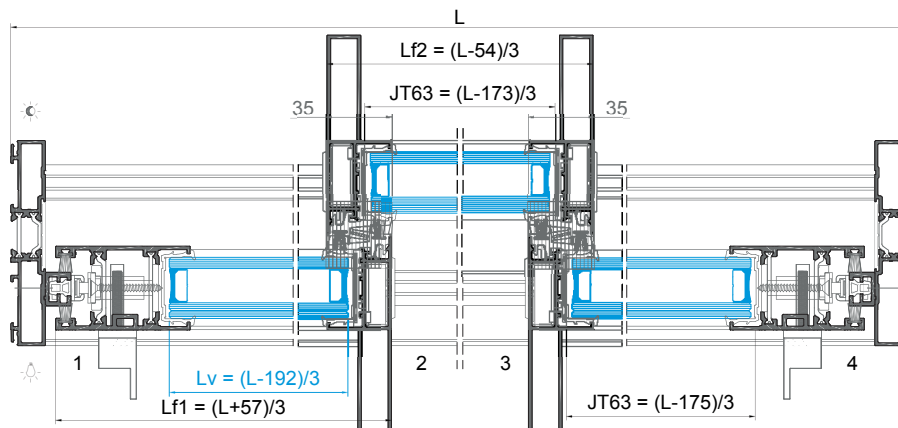

**JANELA DE CORRER 4 FOLHAS 2-RAIL COM OMBREIRA JT18 COM LIGAÇÃO CENTRAL - LINHA SOLEIRA 30MM**  
4 SASHES 2-RAIL AND JT18 JAMB SLIDING WINDOW WITH CENTRAL CONNECTION - 30MM SILL LINE  
FENÊTRE COULISSANT 4 VANTAUX 2-RAIL AVEC JAMBAGE JT18 AVEC CONNEXION CENTRALE - LIGNE SEUIL 30MM

PERFIS   PROFILES   PROFILÉS					
CÓDIGO CODE   CODE	DESIGNAÇÃO DESIGNATION   NOMINATION	CORTE HORIZ. HORIZONTAL CUT COUPE HORIZ.	CORTE VERT. VERTICAL CUT COUPE VERTICALE	QUANT. QUANTITY QUANTITE	CORTE CUT COUPE
JT 12	PADEIRA JAMB   LINTEAU	L-39	-	1	
JT 18	OMBREIRA JAMB   JAMBAGE	-	H	2	
JT 78	GUIA DA OMBREIRA JAMB GUIDE   GUIDE POUR JAMBAGE	-	H-74	2	
JT 22	SOLEIRA SILL   SEUIL	L-39	-	1	
JT 54	PERFIL CENTRAL CENTRAL PROFILE   PROFILÉ CENTRAL	-	H-59	4	
JT 67	PERFIL LATERAL LATERAL PROFILE   PROFILÉ LATÉRAL	-	H-59	4	
JT 63	TRAVESSA SUP/INF UP/LW TRANSOM   TRAVERSE SUP/INF	(L-297)/4	-	8	
JT 71	PERFIL LIGAÇÃO CENTRAL CONNECTION PROFILE   PROFILÉ DE LIAISON	-	H-128	1	
JT 82	PERFIL PINGADEIRA DRIP PROFILE   LARMIER	L-4	-	1	
JT 87	GUIA GUIDE   GUIDE	L-65 L-38	-	1	
JE 96	PERFIL POLIAMIDA POLYAMIDE PROFILE   PROFILÉ DE POLYAMIDE	(L-182)/4 (L-105)/4	H	2 + 2	
208346	JUNTA CENTRAL 2196 CENTRAL JOINT   JOINT CENTRALE	-	H-59	4	
215305	PERFIL PVC U U PVC PROFILE   PROFILÉ PVC U	L-39	-	1	

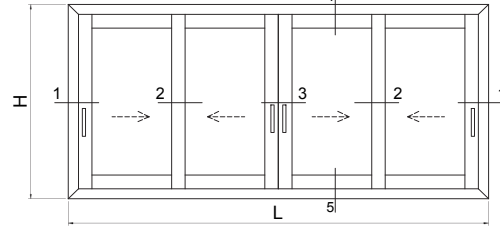

ACESSÓRIOS   ACCESSORIES   ACCESSOIRES			
CÓDIGO CODE   CODE	DESIGNAÇÃO DESIGNATION   NOMINATION	QUANT. QUANTITY QUANTITE	
205129	CARRINHO JT 180KG ROLLER   ROULETTE	8	
213286	CORTA-VENTO JT CENTRAL WATERPROOFING BRUSH   BROSSSE CENTRALE D'ETANCHÉITÉ	3	
213288	CORTA-VENTO BAIXO JT LOW CENTRAL WATERPROOFING BRUSH   BROSSSE CENTRALE D'ETANCHÉITÉ BAS	3	
223105	KIT JUNTAS ADESIVAS Nº1 JT KIT Nº1 ADHESIVE JOINTS KIT   KIT DE JOINTS ADHÉSIFS Nº1 JT	1	
212199	CONJ. TOPOS LAT. JT LATERAL END-CAPS KIT   KIT D'EMBOUS LATERAUX	4	
212230	CONJ. TOPOS INTERIOR LAT. JT LATERAL INNER END-CAPS KIT   KIT D'EMBOUS INTÉRIEUR LATÉRAUX	3	
212201	CONJ. TAMPAS TOPOS LAT. JT LATERAL END-CAP COVERS KIT   KIT DE COUVERTURE POUR EMBOUTS LATÉRAUX	3	
212231	CONJ. TOPOS CENTRAIS JT CENTRAL END-CAPS KIT   KIT D'EMBOUS CENTRAUX	4	
212339	CONJ. TAMPAS TOPOS CENTRAIS JT CENTRAL END-CAP COVERS KIT   KIT DE COUVERTURE POUR EMBOUTS CENTRAUX	4	
210243	TOPO CENTRAL REFORÇADO JT54 28MM 28MM CENTRAL REINFORCED END-CAPS KIT   KIT D'EMBOUS CENTRAUX RENFORCÉ 28MM	8	
212104	CONJ. TOPOS LIG. 2 FOLHAS JT 2 SASHES CONNECTING END-CAPS KIT   KIT D'EMBOUS CONNEXION 2 VANTAUX	1	
210268	GOTEIRA C/ VALV. SVE OUTSIDE FLAP VALVE   CLAPE À VOILET EXTERIEUR	(a)	
211223	FERRAGEM MULTIPONTO CENTR. 1000 MULTIPOINT HARDWARE   SERRURE MULTIPONTO	3	
202491	CONTRA-FECHO ANTI-LEVANTAMENTO MULTIPONTO STRIKING PLATE   GÂCHE	6	
202487	CENTRADOR JT P/ C-FECHO AL MULTIPONTO CENTERING FOR STRIKING PLATE   CENTRAGE JT POUR GÂCHE	4	
212455	CONJ. FIX. CONTRA-FECHO AL MULTIP. JT MULTIPOINT HARDWARE STRIKING PLATE FIXING KIT   KIT FIXATION GÂCHE SERRURE MULTIPONTO	4	
212458	CONJ. FIX. CONTRA-FECHO MULTIP. 2F/90º JT MULTIPOINT HARDWARE STRIKING PLATE FIXING KIT   KIT FIXATION GÂCHE SERRURE MULTIP.	2	
218154	CALÇO P/ C-FECHO PERF. LIG CONNECTING PROFILE STRIKING PLATE SHIM   CALE POUR GÂCHE PROFILÉ DE LIAISON	2	
218198	CALÇO P/ MULTIPONTO SOS JT MULTIPOINT HARDWARE SHIM   CALE POUR MULTIPONTO	18	
212161	CONJ. CENTRADOR P/ FERRAGEM JT CENTERING KIT FOR JT HARDWARE   KIT CENTRAGE POUR SERRURE JT	2	
212162	CONJ. CENTRADOR P/ FERRAGEM JT PERFIL LIG. CENTERING KIT FOR JT HARDWARE   KIT CENTRAGE POUR SERRURE JT	1	
212371	CONJ. FIXAÇÃO JT FIXING KIT   KIT FIXATION	18	
212017	CONJ. FIX. FERRAGEM MULTIP. MULTIPOINT HARDWARE FIXING KIT   KIT FIXATION POUR SERRURE MULTIPONTO	1 + 1 un./m (min. 4)	
200819	PUXADOR SLIM XS - ESQUERDO LEFT HANDLE   POIGNÉE GAUCHE	1	
200817	PUXADOR SLIM XS - DIREITO RIGHT HANDLE   POIGNÉE DROITE	2	
200057	PUXADOR FOLHA PASSIVA SLIM XS PASSIVE SASH HANDLE   POIGNÉE VENTAIL PASSIVE	1	
212384	CONJ. TOPOS LAT. PINGADEIRA JT82 LATERAL DRIP END-CAPS KIT   KIT D'EMBOUS LATÉRAUX POUR REJET D'EAU	1	
228107	LIMITADOR ABERT. PQ SERIE CORRER SPRING LIMITER   LIMITEUR D'OUVRETURE	2	
290052	PARAF DIN7982 PH 3,5x16 A2 SCREW   VIS	1 + 4 un./m	
290262	PARAFUSO PK INOX PH 1 1/2X10 CQ SCREW   VIS	32	
290030	PARAFUSO DIN7981 4,2x38 INOX A2 SCREW   VIS	8	
218137	CALÇO REFORÇO HORIZONTAL JT * HORIZONTAL REINFORCEMENT SHIM   CALE DE RENFORCEMENT HORIZONTALE	8	

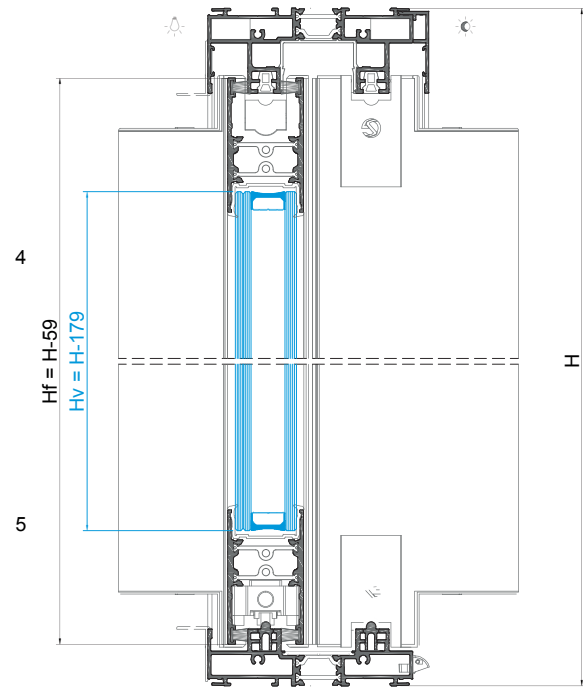

VEDANTES   SEALS   JOINTS		
CÓDIGO CODE   CODE	DESIGNAÇÃO DESIGNATION   NOMINATION	QUANT. QUANTITY QUANTITE
208348	JUNTA TAPA CANAL 2116 JT JOINT   JOINT	2L + 2H
208099	JUNTA VIDRO U 1032 CX 32MM JT GLAZING GASKET   JOINT DE VITRAGE	2L + 8H
208307	PELUCIA 7x10 TRI-FIN PRETA PILE SEAL   JOINT BROUSSE	4L + 12H
208479	JUNTA TAPA CANAL PERFIL LIG. 2117 JT JOINT   JOINT	H

\* Usar em folhas com vidros com peso superior a 80kg  
To be used in sashes which glass weight exceed 80kg | Utiliser dans des panneaux de verre d'un poids supérieur à 80 kg  
(a) Conforme esquemas de drenagem (Capítulo V - Maquinações)  
According to drainage schemes (Chapter V - Machinings) | Selon les schémas de drainage (Chapitre V - Usinages)

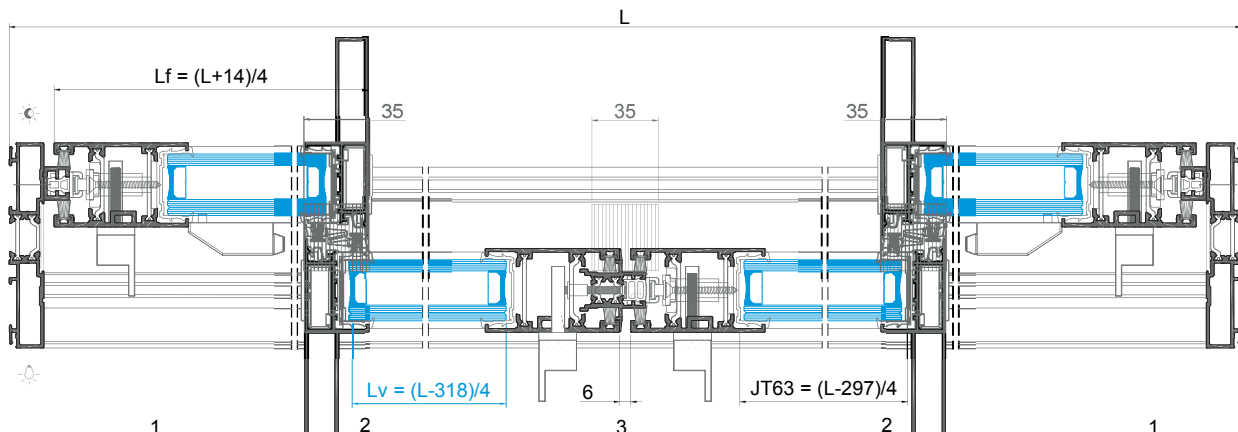

**JANELA DE CORRER 4 FOLHAS 2-RAIL CANTO 90° COM OMBREIRA JT18 - LINHA SOLEIRA 30MM**  
4 SASHES 2-RAIL WITH JT18 JAMB SLIDING WINDOW 90° CORNER - 30MM SILL LINE  
FENÊTRE COULISSANT 4 VANTAUX AVEC JAMBAGE JT18 À ANGLE 90° - LIGNE SEUIL 30MM

PERFIS   PROFILES   PROFILÉS					
CÓDIGO CODE   CODE	DESIGNAÇÃO DESIGNATION   NOMINATION	CORTE HORIZ. HORIZONTAL CUT COUPE HORIZ.	CORTE VERT. VERTICAL CUT COUPE VERTICALE	QUANT. QUANTITY QUANTITE	CORTE CUT COUPE
JT 12	PADEIRA SILL   LINTEAU	L1-19 L2-19	-	1	
JT 18	OMBREIRA JAMB   JAMBAGE	-	H	2	
JT 76	GUIA DA OMBREIRA JAMB GUIDE   GUIDE POUR JAMBAGE	-	H-74	2	
JT 22	SOLEIRA SILL   SEUIL	L1-19 L2-19	-	1	
JT 54	PERFIL CENTRAL CENTRAL PROFILE   PROFILÉ CENTRAL	-	H-59	4	
JT 67	PERFIL LATERAL LATERAL PROFILE   PROFILÉ LATÉRAL	-	H-59	2	
JT 62	PERFIL LIGAÇÃO CANTO 90° CONNECTION PROFILE   PROFILÉ DE LIAISON	-	H-59	2	
JT 63	TRAVESSA SUP/INF UP/LOW TRANSOM   TRAVERSE SUP/INF	(L1-238)/2 (L2-251)/2	-	4 4	
JT 72	PERFIL LIGAÇÃO CENTRAL CONNECTION PROFILE   PROFILÉ DE LIAISON	-	H-128	1	
JT 82	PERFIL PINGADEIRA DRIP PROFILE   L'ARMIER	L1+6 L2+6	-	1	
JT 87	GUIA GUIDE   GUIDE	L1-50 L1-93 L2-50 L2-93	-	1 1 1 1	
JE 96	PERFIL POLIAMIDA POLYAMIDE PROFILE   PROFILÉ DE POLYAMIDE	(L1-144)/2 (L1-27)/2 (L2-15)/2 (L2-156)/2	H	1 1 1 1	
208346	JUNTA CENTRAL 2196 CENTRAL JOINT   JOINT CENTRALE	-	H-59	4	
215305	PERFIL PVC U U PVC PROFILE   PROFILÉ PVC U	L1-19 L2-19	-	1	

VEDANTES   SEALS   JOINTS		
CÓDIGO CODE   CODE	DESIGNAÇÃO DESIGNATION   NOMINATION	QUANT. QUANTITY QUANTITE
208348	JUNTA TAPA CANAL 2116 JT JOINT   JOINT	2L1 + 2H
208099	JUNTA VIDRO U 1032 CX 32MM JT GLAZING GASKET   JOINT DE VITRAGE	2L1 + 8H
208307	PELUCIA 7x10 TRI-FIN PRETA PILE SEAL   JOINT BRUSSE	4L1 + 13H
208479	JUNTA TAPA CANAL PERFIL LIG. 2117 JT JOINT   JOINT	H
208435	JUNTA VD 2415 JOINT   JOINT	H

As fórmulas foram concebidas para medidas de vidros iguais. Nesta tipologia existem 4 larguras de folha distintas: Lf1, Lf2, Lf3 e Lf4.  
The formulas were designed for glasses with equal measures. In this typology there are 4 distinct sash widths: Lf1, Lf2, Lf3 and Lf4.  
Les formules sont conçues pour mesurer le verre. Dans cette typologie, il existe 4 largeurs de vantaux distinctes: Lf1, Lf2, Lf3 et Lf4.

ACESSÓRIOS   ACCESSORIES   ACCESSOIRES		
CÓDIGO CODE   CODE	DESIGNAÇÃO DESIGNATION   NOMINATION	QUANT. QUANTITY QUANTITE
205129	CARRINHO JT 180KG ROLLER   ROULETTE	8
213286	CORTA-VENTO JT CENTRAL WATERPROOFING BRUSH   BRUSSE CENTRALE D'ÉTANCHÉITÉ	2
213288	CORTA-VENTO BAIXO JT LOW CENTRAL WATERPROOFING BRUSH   BRUSSE CENTRALE D'ÉTANCHÉITÉ BAS	5
213287	CORTA-VENTO CANTO 90° JT 90° CORNER WATERPROOFING BRUSH   BRUSSE D'ÉTANCHÉITÉ ANGLE 90°	1
223105	KIT JUNTAS ADESIVAS Nº1 JT JT Nº1 ADHESIVE JOINTS KIT   KIT DE JOINTS ADHÉSIFS Nº1 JT	1
212243	CONJ. UNIÃO CANTO 90° JT 90° CORNER UNION KIT   KIT D'UNION ANGLE 90°	1
212109	CONJ. UNIÃO CANTO 90° ARO BAIXO JT 90° CORNER LOW FRAME UNION KIT   KIT D'UNION ANGLE 90° POUR CADRE BAS	1
204389	ESQUADRO INOX CANTO 90° 90° STAINLESS STEEL CORNER   ANGLE EN ACIER INOXYDABLE 90°	1
212199	CONJ. TOPOS LAT. JT LATERAL END-CAPS KIT   KIT D'EMBOUTS LATÉRAUX	4
212230	CONJ. TOPOS INTERIOR LAT. JT LATERAL INNER END-CAPS KIT   KIT D'EMBOUTS INTÉRIEUR LATÉRAUX	3
212201	CONJ. TAMPAS TOPOS LAT. JT LATERAL END-CAP COVERS KIT   KIT DE COUVERTURE POUR EMBOUTS LATÉRAUX	3
212231	CONJ. TOPOS CENTRAIS JT CENTRAL END-CAPS KIT   KIT D'EMBOUTS CENTRAUX	4
212339	CONJ. TAMPAS TOPOS CENTRAIS JT CENTRAL END-CAP COVERS KIT   KIT DE COUVERTURE POUR EMBOUTS CENTRAUX	4
210243	TOPO CENTRAL REFORÇADO JT54 28MM 28MM CENTRAL REINFORCED END-CAPS KIT   KIT D'EMBOUTS CENTRAUX RENFORCÉ 28MM	8
212109	CONJ. TOPOS CANTO 90° JT 90° CORNER END-CAPS KIT   KIT D'EMBOUTS POUR ANGLE 90°	1
210268	GOTEIRA C/ VALV. SVE OUTSIDE FLAP VALVE   CLAPE À VOLET EXTÉRIEUR	(a)
211223	FERRAGEM MULTIPONTO CENTR. 1000 MULTIPOINT HARDWARE   SERRURE MULTIPONT	3
202491	CONTRA-FECHO ANTI-LEVANTAMENTO MULTIPONTO STRIKING PLATE   GÂCHE	6
202487	CENTRADOR JT P/ C-FECHO AL MULTIPONTO JT CENTERING FOR STRIKING PLATE   CENTRAGE JT POUR GÂCHE	4
212455	CONJ. FIX. CONTRA-FECHO AL MULTIP. JT MULTIPOINT HARDWARE STRIKING PLATE FIXING KIT   KIT FIXATION GÂCHE SERRURE MULTIPONT	4
212458	CONJ. FIX. CONTRA-FECHO MULTIP. 2F/90° JT MULTIPOINT HARDWARE STRIKING PLATE FIXING KIT   KIT FIXATION GÂCHE SERRURE MULTIP.	2
218154	CALÇO P/ C-FECHO PERF. LIG CONNECTING PROFILE STRIKING PLATE SHIM   CALE POUR GÂCHE PROFILÉ DE LIAISON	2
218198	CALÇO P/ MULTIPONTO SOS JT MULTIPOINT HARDWARE SHIM   CALE POUR MULTIPONT	18
212161	CONJ. CENTRADOR P/ FERRAGEM JT CENTERING KIT FOR JT HARDWARE   KIT CENTRAGE POUR SERRURE JT	2
212162	CONJ. CENTRADOR P/ FERRAGEM JT PERFIL LIG. CENTERING KIT FOR JT HARDWARE   KIT CENTRAGE POUR SERRURE JT	1
212371	CONJ. FIXAÇÃO JT FIXING KIT   KIT FIXATION	18
212079	CONJ. FIX. FERRAGEM MULTIP. JT72 MULTIPOINT FIXING KIT   KIT FIXATION SERRURE MULTIPONT	1 + 4 un./m (min. 4)
200819	PUXADOR SLIM XS - ESQUERDO LEFT HANDLE   POIGNÉE GAUCHE	1
200817	PUXADOR SLIM XS - DIREITO RIGHT HANDLE   POIGNÉE DROITE	2
212384	CONJ. TOPOS LAT. PINGADEIRA JT82 LATERAL DRIP END-CAPS KIT   KIT D'EMBOUTS LATÉRAUX POUR REJET D'EAU	1
228107	LIMITADOR ABERT. PQ SERIE CORRER OPENING LIMITER   LIMITEUR D'OUVERTURE	2
290052	PARAF DIN7982 PH 3,5x16 A2 SCREW   VIS	1 + 4 un./m
290262	PARAFUSO PK INOX PH 1 1/2x10 CQ SCREW   VIS	32
290030	PARAFUSO DIN7981 4,2x38 INOX A2 SCREW   VIS	8
218137	CALÇO REFORÇO HORIZONTAL JT * HORIZONTAL REINFORCEMENT SHIM   CALE DE RENFORCEMENT HORIZONTALE	8

\* Usar em folhas com vidros com peso superior a 80kg  
To be used in sashes with glasses which glass weight exceed 80kg | Utiliser dans des panneaux de verre d'un poids supérieur à 80 kg

(a) Conforme esquemas de drenagem (Capítulo V - Maquinações)  
According to drainage schemes (Chapter V - Machinings)  
Selon les schémas de drainage (Chapitre V - Usinages)

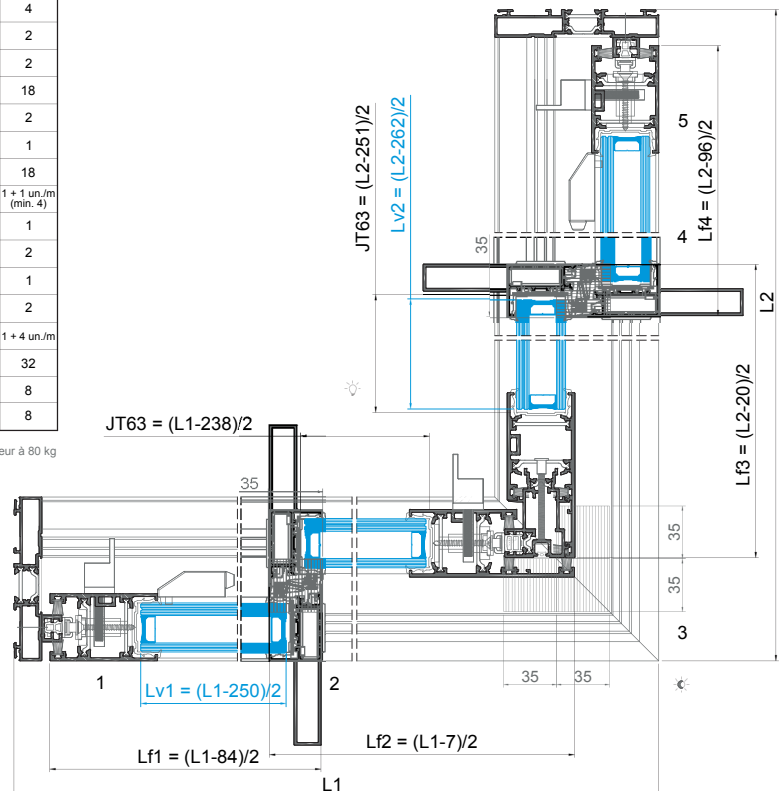
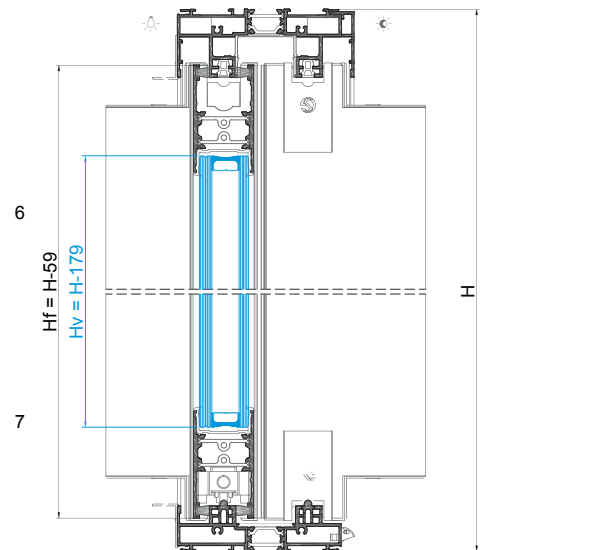
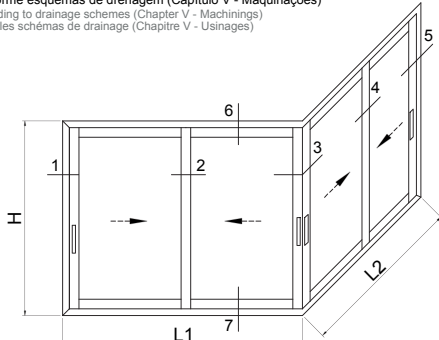

**JANELA DE CORRER 3 FOLHAS 3-RAIL COM OMBREIRA JT28 - LINHA SOLEIRA 30MM**  
3 SASHES 3-RAIL WITH JT28 JAMB SLIDING WINDOW - 30MM SILL LINE  
FENÊTRE COULISSANT 3 VANTAOX 3-RAIL AVEC JAMBAGE JT28 - LIGNE SEUIL 30MM

PERFIS   PROFILÉS   PROFILÉS					
CÓDIGO CODE   CODE	DESIGNAÇÃO DESIGNATION   NOMINATION	CORTE HORIZ. HORIZONTAL CUT COUPE HORIZ.	CORTE VERT. VERTICAL CUT COUPE VERTICALE	QUANT. QUANTITY QUANTITÉ	CORTE CUT COUPE
JT 13	PADEIRA LINTAU   LINTEAU	L-39	-	1	
JT 28	OMBREIRA JAMB   JAMBAGE	-	H	2	
JT 78	GUIA DA OMBREIRA JAMB GUIDE   GUIDE POUR JAMBAGE	-	H-74	2	
JT 23	SOLEIRA SILL   SEUIL	L-39	-	1	
JT 54	PERFIL CENTRAL CENTRAL PROFILE   PROFILÉ CENTRAL	-	H-59	4	
JT 67	PERFIL LATERAL LATERAL PROFILE   PROFILÉ LATÉRAL	-	H-59	2	
JT 63	TRAVESSA SUP/INF UP/CROSS - WATERPROOF BRUSH L-176)/3 (L-174)/3	(L-176)/3 (L-174)/3	-	4 2	
JT 82	PERFIL PINGADEIRA DRIP PROFILE   L'ARMIER	L-4	-	1	
JT 87	GUIA GUIDE   GUIDE	L-51 L-38	-	2 1	
JE 96	PERFIL POLIAMIDA POLYAMIDE PROFILE   PROFILÉ DE POLYAMIDE	(L-30)/3 (2L-186)/3	H	2 + 4	
208346	JUNTA CENTRAL 2116 CENTRAL JOINT   JOINT CENTRALE	-	H-59	4	
215305	PERFIL PVC U U PVC PROFILE   PROFILÉ PVC U	L-39	-	2	

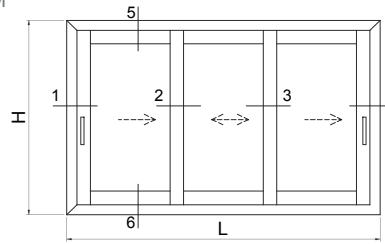

ACESSÓRIOS   ACCESSORIES   ACCESSOIRES		
CÓDIGO CODE   CODE	DESIGNAÇÃO DESIGNATION   NOMINATION	QUANT. QUANTITY QUANTITÉ
205129	CARRINHO JT 180KG ROLLER   ROULETTE	6
213286	CORTA-VENTO JT CENTRAL WATERPROOFING BRUSH   Brosse centrale d'étanchéité	2
213288	CORTA-VENTO BAIXO JT LOW CENTRAL WATERPROOFING BRUSH   Brosse centrale d'étanchéité bas	2
223106	KIT JUNTAS ADESIVAS Nº2 JT JT Nº2 ADHESIVE JOINTS KIT   KIT DE JOINTS ADHÉSIFS Nº2 JT	1
212199	CONJ. TOPOS LAT. JT LATERAL END-CAPS KIT   KIT D'EMBOUITS LATÉRAUX	2
212230	CONJ. TOPOS INTERIOR LAT. JT LATERAL INNER END-CAPS KIT   KIT D'EMBOUITS INTÉRIEUR LATÉRAUX	2
212201	CONJ. TAMPAS TOPOS LAT. JT LATERAL END-CAP COVERS KIT   KIT DE COUVERTURE POUR EMBOUTS LATÉRAUX	2
212231	CONJ. TOPOS CENTRAIS JT CENTRAL END-CAPS KIT   KIT D'EMBOUITS CENTRAUX	4
212339	CONJ. TAMPAS TOPOS CENTRAIS JT CENTRAL END-CAP COVERS KIT   KIT DE COUVERTURE POUR EMBOUTS CENTRAUX	4
210243	TOPO CENTRAL REFORÇADO JT54 28MM 28MM CENTRAL REINFORCED END-CAPS KIT   KIT D'EMBOUITS CENTRAUX RENFORCÉ 28MM	8
210268	GOTEIRA C/ VALV. SVE OUTSIDE FLAP VALVE   CLAPE À VOILET EXTERIEUR	(a)
211223	FERRAGEM MULTIPONTO CENTR. 1000 MULTIPOINT HARDWARE   SERRURE MULTIPONT	2
202491	CONTRA-FECHO ANTI-LEVANTAMENTO MULTIPONTO STRIKING PLATE   GÂCHE	4
202487	CENTRADOR JT P/ C-FECHO AL MULTIPONTO JT CENTERING FOR STRIKING PLATE   CENTRAGE JT POUR GÂCHE	4
212455	CONJ. FIX. CONTRA-FECHO AL MULTIP. JT MULTIPOINT HARDWARE STRIKING PLATE FIXING KIT   KIT FIXATION GÂCHE SERRURE MULTIPONT	4
218198	CALÇO P/ MULTIPONTO SOS JT MULTIPOINT HARDWARE SHIM   CALE-POUR MULTIPONT	12
212161	CONJ. CENTRADOR P/ FERRAGEM JT CENTERING KIT FOR JT HARDWARE   KIT CENTRAGE POUR SERRURE JT	2
212371	CONJ. FIXAÇÃO JT FIXING KIT   KIT FIXATION	12
200819	PUXADOR SLIM XS - ESQUERDO LEFT HANDLE   POIGNEE GAUCHE	1
200817	PUXADOR SLIM XS - DIREITO RIGHT HANDLE   POIGNEE DROITE	1
212384	CONJ. TOPOS LAT. PINGADEIRA JT82 LATERAL DRIP END-CAPS KIT   KIT D'EMBOUITS LATÉRAUX POUR REJET D'EAU	1
228107	LIMITADOR ABERT. PQ SERIE CORRER OPENING LIMITER   LIMITEUR D'OUVERTURE	1
290052	PARAF DIN7982 PH 3,5x16 A2 SCREW   VIS	1 + 4 un./m
290262	PARAFUSO PK INOX PH 1 1/2x10 CQ SCREW   VIS	24
290030	PARAFUSO DIN7981 4,2x38 INOX A2 SCREW   VIS	12
218137	CALÇO REFORÇO HORIZONTAL JT * HORIZONTAL REINFORCEMENT SHIM   CALE DE RENFORCEMENT HORIZONTALE	6

\* Usar em folhas com vidros com peso superior a 80kg  
To be used in sashes which glass weight exceed 80kg | Utiliser dans des panneaux de verre d'un poids supérieur à 80 kg  
(a) Conforme esquemas de drenagem (Capítulo V - Maquinações)  
According to drainage schemes (Chapter V - Machinings) | Selon les schémas de drainage (Chapitre V - Usinages)

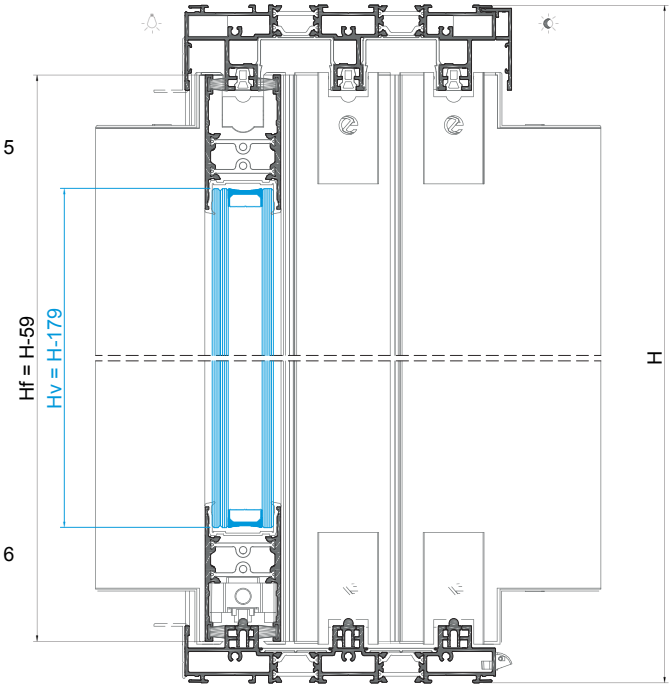

VEDANTES   SEALS   JOINTS		
CÓDIGO CODE   CODE	DESIGNAÇÃO DESIGNATION   NOMINATION	QUANT. QUANTITY QUANTITÉ
208348	JUNTA TAPA CANAL 2116 JT JOINT   JOINT	3L + 2H
208099	JUNTA VIDRO U 1032 CX 32MM JT GLAZING GASKET   JOINT DE VITRAGE	2L + 6H
208307	PELUCIA 7x10 TRI-FIN PRETA PILE SEAL   JOINT BROUSSE	4L + 8H

As fórmulas foram concebidas para medidas de vidros iguais.  
Nesta tipologia existem 2 larguras de folha distintas: Lf1 e Lf2.  
The formulas were designed for glasses with equal measures. In this typology there are 2 distinct sash widths: Lf1 and Lf2.  
Les formules sont conçues pour mesurer le verre. Dans cette typologie, il existe 2 largeurs de vantaux distinctes: Lf1 et Lf2.

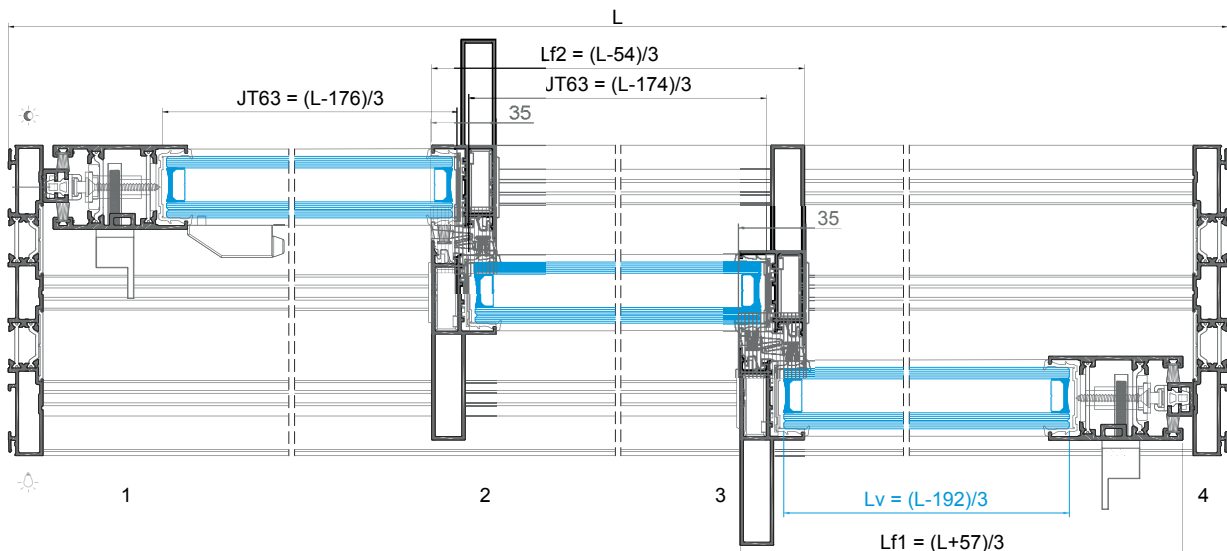



JANELA DE CORRER 3 FOLHAS 3-RAIL COM OMBREIRA JT27/JT29 - LINHA SOLEIRA 30MM

3 SASHES 3-RAIL WITH JT27/JT29 JAMB SLIDING WINDOW - 30MM SILL LINE

FENÊTRE COULISSANT 3 VANTAUX 3-RAIL AVEC JAMBAGE JT27/JT29 - LIGNE SEUIL 30MM

PERFIS   PROFILES   PROFILÉS					
CÓDIGO CODE   CODE	DESIGNAÇÃO DESIGNATION   NOMINATION	CORTE HORIZ. HORIZONTAL CUT COUPE HORIZ.	CORTE VERT. VERTICAL CUT COUPE VERTICALE	QUANT. QUANTITY QUANTITÉ	CORTE CUT COUPE
JT 13	PADEIRA LINTEAU	L-39	-	1	
JT 27	OMBREIRA JAMB   JAMBAGE	-	H	1	
JT 29	OMBREIRA JAMB   JAMBAGE	-	H	1	
JT 23	SOLEIRA SILL   SEUIL	L-39	-	1	
JT 54	PERFIL CENTRAL CENTRAL PROFILE   PROFILÉ CENTRAL	-	H-59	4	
JT 67	PERFIL LATERAL LATERAL PROFILE   PROFILÉ LATÉRAL	-	H-59	2	
JT 63	TRAVESSA SUP/INF UP/CW TRANSVERSE SUP/INF	(L-172)/3 (L-170)/3	-	4 2	
JT 82	PERFIL PINGADEIRA DRIP PROFILE   L'ARMIER	L-4	-	1	
JT 87	GUIA GUIDE   GUIDE	L-49 L-38	-	2 1	
JE 96	PERFIL POLIAMIDA POLYAMIDE PROFILE   PROFILÉ DE POLYAMIDE	(L-35)/3 (2L-186)/3	H	2 + 4	
208346	JUNTA CENTRAL 2116 CENTRAL JOINT   JOINT CENTRALE	-	H-59	4	
215305	PERFIL PVC U U PVC PROFILE   PROFILÉ PVC U	L-39	-	2	

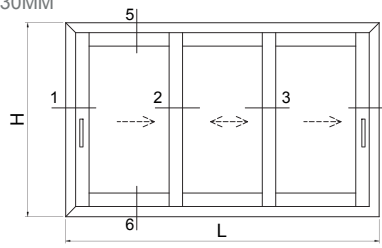

ACESSÓRIOS   ACCESSORIES   ACCESSOIRES		
CÓDIGO CODE   CODE	DESIGNAÇÃO DESIGNATION   NOMINATION	QUANT. QUANTITY QUANTITÉ
205129	CARRINHO JT 180KG ROLLER   ROULETTE	6
213286	CORTA-VENTO JT CENTRAL WATERPROOFING BRUSH   BROSSE CENTRALE D'ÉTANCHÉITÉ	2
213288	CORTA-VENTO BAIXO JT LOW CENTRAL WATERPROOFING BRUSH   BROSSE CENTRALE D'ÉTANCHÉITÉ BAS	2
223106	KIT JUNTAS ADESIVAS Nº2 JT JT Nº2 ADHESIVE JOINTS KIT   KIT DE JOINTS ADHÉSIFS Nº2 JT	1
212199	CONJ. TOPOS LAT. JT LATERAL END-CAPS KIT   KIT D'EMBOÛTS LATÉRAUX	2
212230	CONJ. TOPOS INTERIOR LAT. JT LATERAL INNER END-CAPS KIT   KIT DE COUVERTURE POUR EMBOUTS INTÉRIEUR LATÉRAUX	2
212201	CONJ. TAMPAS TOPOS LAT. JT LATERAL END-CAP COVERS KIT   KIT DE COUVERTURE POUR EMBOUTS LATÉRAUX	2
212231	CONJ. TOPOS CENTRAIS JT CENTRAL END-CAPS KIT   KIT D'EMBOÛTS CENTRAUX	4
212339	CONJ. TAMPAS TOPOS CENTRAIS JT CENTRAL END-CAP COVERS KIT   KIT DE COUVERTURE POUR EMBOUTS CENTRAUX	4
210243	TOPO CENTRAL REFORÇADO JT54 28MM 28MM CENTRAL REINFORCED END-CAPS KIT   KIT D'EMBOÛTS CENTRAUX RENFORCÉ 28MM	8
210268	GOTEIRA C/ VALV. SVE OUTSIDE FLAP VALVE   CLAPE À VOLET EXTÉRIEUR	(a)
211223	FERRAGEM MULTIPONTO CENTR. 1000 MULTIPOINT HARDWARE   SERRURE MULTIPONT	2
202491	CONTRA-FECHO ANTI-LEVANTAMENTO MULTIPONTO STRIKING PLATE   GÂCHE	4
202487	CENTRADOR JT P/ C-FECHO AL MULTIPONTO JT CENTERING FOR STRIKING PLATE   CENTRAGE JT POUR GÂCHE	4
212455	CONJ. FIX. CONTRA-FECHO AL MULTIP. JT MULTIPOINT HARDWARE STRIKING PLATE FIXING KIT   KIT FIXATION GÂCHE SERRURE MULTIPONT	4
218198	CALÇO P/ MULTIPONTO SOS JT MULTIPOINT HARDWARE SHIM   CALE POUR MULTIPONT	12
212161	CONJ. CENTRADOR P/ FERRAGEM JT CENTERING KIT FOR JT HARDWARE   KIT CENTRAGE POUR SERRURE JT	2
212371	CONJ. FIXAÇÃO JT FIXING KIT   KIT FIXATION	12
200819	PUXADOR SLIM XS - ESQUERDO LEFT HANDLE   POIGNÉE GAUCHE	1
200817	PUXADOR SLIM XS - DIREITO RIGHT HANDLE   POIGNÉE DROITE	1
212384	CONJ. TOPOS LAT. PINGADEIRA JT82 LATERAL DRIP END-CAPS KIT   KIT D'EMBOÛTS LATÉRAUX POUR REJET D'EAU	1
228107	LIMITADOR ABERT. PQ SERIE CORRER OPENING LIMITER   LIMITÉUR D'OUVERTURE	1
290262	PARAFUSO PK INOX PH 1 1/2X10 CQ SCREW   VIS	24
290030	PARAFUSO DIN7981 4,2x38 INOX A2 SCREW   VIS	12
218137	CALÇO REFORÇO HORIZONTAL JT * HORIZONTAL REINFORCEMENT SHIM   CALE DE RENFORCEMENT HORIZONTALE	6

\* Usar em folhas com vidros com peso superior a 80kg  
To be used in sashes with glass weight exceed 80kg | Utiliser dans des panneaux de verre d'un poids supérieur à 80 kg  
(a) Conforme esquemas de drenagem (Capítulo V - Maquinações)  
According to drainage schemes (Chapter V - Machinings) | Selon les schémas de drainage (Chapitre V - Usinages)

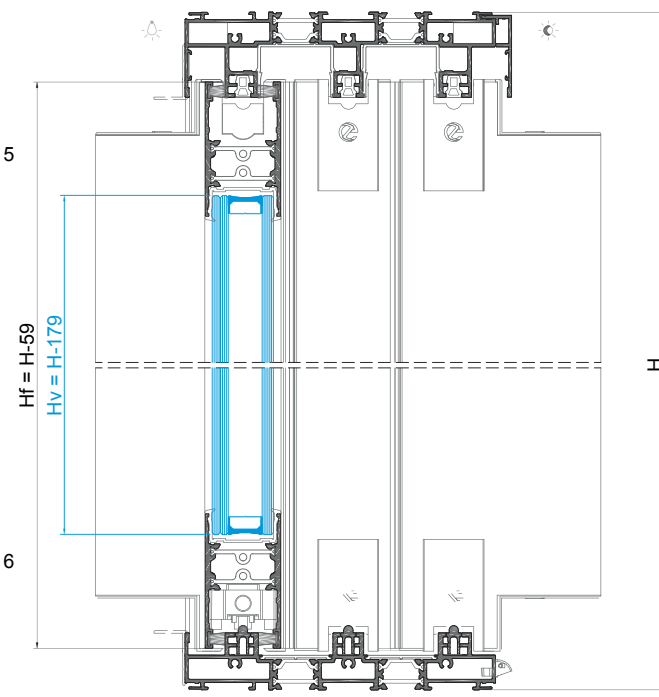

VEDANTES   SEALS   JOINTS		
CÓDIGO CODE   CODE	DESIGNAÇÃO DESIGNATION   NOMINATION	QUANT. QUANTITY QUANTITÉ
208348	JUNTA TAPA CANAL 2116 JT JOINT   JOINT	3L + 2H
208099	JUNTA VIDRO U 1032 CX 32MM JT GLAZING GASKET   JOINT DE VITRAGE	2L + 6H
208307	PELUCIA 7x10 TRI-FIN PRETA FILE SEAL   JOINT BROUSSE	4L + 8H

As fórmulas foram concebidas para medidas de vidros iguais.  
Nesta tipologia existem 2 larguras de folha distintas: Lf1 e Lf2.  
The formulas were designed for glasses with equal measures. In this typology there are 2 distinct sash widths: Lf1 and Lf2.  
Les formules sont conçues pour mesurer le verre. Dans cette typologie, il existe 2 largeurs de vantaux distinctes: Lf1 et Lf2.

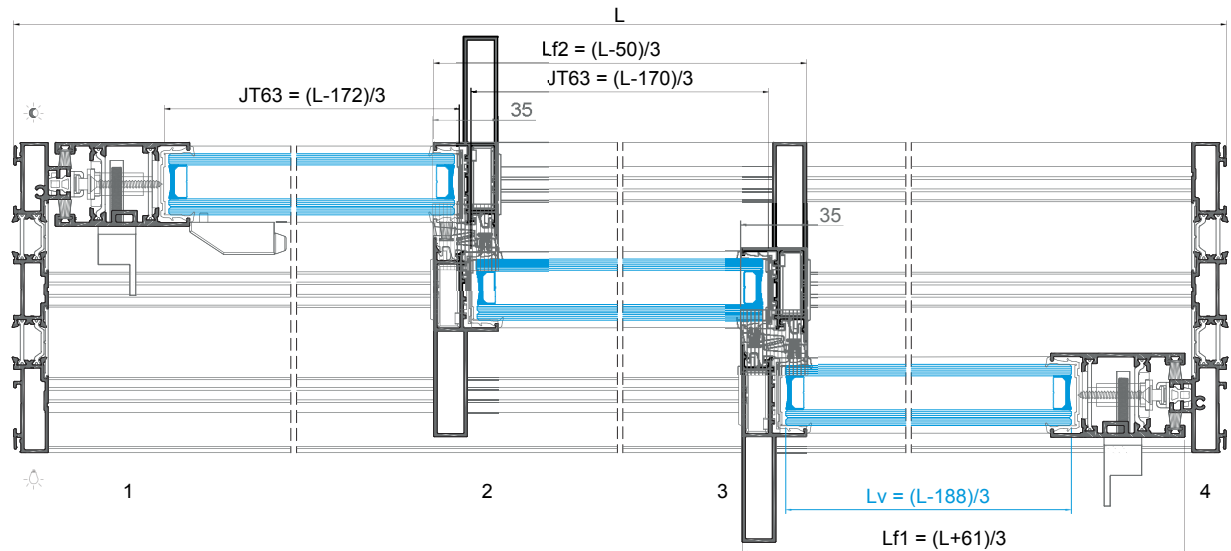

**JANELA DE CORRER 1 FOLHA DE EMBUTIR 2-RAIL COM OMBREIRA JT18 - LINHA SOLEIRA 30MM**  
1 SASH POCKET 2-RAIL WITH JT18 JAMB SLIDING WINDOW - 30MM SILL LINE  
FENÊTRE COULISSANT 1 VANTAIL 2-RAIL AVEC JAMBAGE JT18 À GALANDAGE - LIGNE SEUIL 30MM

PERFIS   PROFILES   PROFILÉS					
CÓDIGO CODE / CODE	DESIGNAÇÃO DESIGNATION / NOMINATION	CORTE HORIZ. HORIZONTAL CUT COUPE HORIZ.	CORTE VERT. VERTICAL CUT COUPE VERTICALE	QUANT. QUANTITY QUANTITÉ	CORTE CUT COUPE
JT 12	PADEIRA UNITE / LINTEAU	2L-74	-	1	
JT 18	OMBREIRA JAMB / JAMBAGE	-	H	2	
JT 76	GUIA DA OMBREIRA JAMB GUIDE / GUIDE POUR JAMBAGE	-	H-74	1	
JT 22	SOLEIRA SILL / SEUIL	2L-74	-	1	
JT 51	PERFIL CENTRAL CENTRAL PROFILE / PROFILÉ CENTRAL	-	H-74	1	
JT 67	PERFIL LATERAL LATERAL PROFILE / PROFILÉ LATÉRAL	-	H-74	1	
JT 63	TRAVESSA SUP/INF CENTRAL TRANSOM / TRAVERSE SUP/INF	L-68	-	2	
JT 85	CAPA COVER / CAPOT	L-18	-	2	
JT 87	GUIA GUIDE / GUIDE	2L-88	-	1	
JT 93	PERFIL MONTANTE MULION PROFILE / PROFILÉ DE MENEAU	-	H-38	1	
SO 46	PERFIL REMATE FINISHING PROFILE / PROFILÉ DE FINITION	-	H-75	1	
SO 47	PERFIL REMATE FINISHING PROFILE / PROFILÉ DE FINITION	-	H-75	1	
SO 48	PERFIL REMATE FINISHING PROFILE / PROFILÉ DE FINITION	L+97	H+25	2 + 1	
KE 71	PERFIL REMATE FINISHING PROFILE / PROFILÉ DE FINITION	L-6	-	1	
KE 60	PERFIL REMATE FINISHING PROFILE / PROFILÉ DE FINITION	2L+23 L-6	H+60	1 + 2	
JE 96	PERFIL POLIAMIDA POLYAMIDE PROFILE / PROFILÉ DE POLYAMIDE	L-91 L-20	H	1 + 2	
208346	JUNTA CENTRAL 2196 CENTRAL JOINT / JOINT CENTRALE	-	H-74	2	
215305	PERFIL PVC U UPVC PROFILE / PROFILÉ PVC U	2L-74	-	1	

VEDANTES   SEALS   JOINTS		
CÓDIGO CODE / CODE	DESIGNAÇÃO DESIGNATION / NOMINATION	QUANT. QUANTITY QUANTITÉ
208348	JUNTA TAPA CANAL 2116 JT JOINT / JOINT	2L + H
208099	JUNTA VIDRO U 1032 CX 32MM JT GLAZING GASKET / JOINT DE VITRAGE	2L + 2H
208307	PELUCIA 7x10 TRI-FIN PRETA PILE SEAL / JOINT BRASSE	6L + 4H
208486	PELUCIA 7x12 STOP-FIN PRETA PILE SEAL / JOINT BRASSE	H

ACESSÓRIOS   ACCESSORIES   ACCESSOIRES		
CÓDIGO CODE / CODE	DESIGNAÇÃO DESIGNATION / NOMINATION	QUANT. QUANTITY QUANTITÉ
205129	CARRINHO JT 180KG ROLLER / ROULETTE	2
213286	CORTA-VENTO JT CENTRAL WATERPROOFING BRUSH / BRASSE CENTRALE D'ÉTANCHÉITÉ	1
213288	CORTA-VENTO BAIXO JT LOW CENTRAL WATERPROOFING BRUSH / BRASSE CENTRALE D'ÉTANCHÉITÉ BAS	1
223105	KIT JUNTAS ADESIVAS Nº1 JT KIT Nº1 ADHESIVE JOINTS KIT / KIT DE JOINTS ADHÉSIFS Nº1 JT	1
213246	CANTO CR S/SB CORNER / ANGLE	3
212199	CONJ. TOPOS LAT. JT LATERAL END-CAPS KIT / KIT D'EMBOUS LATÉRAUX	1
212230	CONJ. TOPOS INTERIOR LAT. JT LATERAL INNER END-CAPS KIT / KIT D'EMBOUS INTÉRIEUR LATÉRAUX	1
212201	CONJ. TAMPAS TOPOS LAT. JT LATERAL END-CAP COVERS KIT / KIT DE COUVERTURE POUR EMBOUTS LATÉRAUX	1
212231	CONJ. TOPOS CENTRAIS JT CENTRAL END-CAPS KIT / KIT D'EMBOUS CENTRAUX	1
212339	CONJ. TAMPAS TOPOS CENTRAIS JT CENTRAL END-CAP COVERS KIT / KIT DE COUVERTURE POUR EMBOUTS CENTRAUX	1
210268	GOTEIRA C/ VALV. SVE OUTSIDE FLAP VALVE / CLAPE À VOLET EXTÉRIEUR	(a)
210265	GOTEIRA C/ VALV. BOLA PRT (OPCIONAL) BALL VALVE (OPTIONAL) / CLAPETS À BILLE (OPTIONEL)	4
211223	FERRAGEM MULTIPONTO CENTR. 1000 MULTIPOINT HARDWARE / SERRURE MULTIPONT	1
202491	CONTRA-FECHO ANTI-LEVANTAMENTO MULTIPONTO STRIKING PLATE / GÂCHE	2
202487	CENTRADOR JT P/ C-FECHO AL MULTIPONTO JT CENTERING FOR STRIKING PLATE / CENTRAGE JT POUR GÂCHE	2
212455	CONJ. FIX. CONTRA-FECHO AL MULTIP. JT MULTIPOINT HARDWARE STRIKING PLATE FIXING KIT / KIT FIXATION GÂCHE SERRURE MULTIPONT	2
218198	CALÇO P/ MULTIPONTO SOS JT MULTIPOINT HARDWARE SHIM / CALE POUR MULTIPONT	6
212161	CONJ. CENTRADOR P/ FERRAGEM JT CENTERING KIT FOR JT HARDWARE / KIT CENTRAGE POUR SERRURE JT	1
212371	CONJ. FIXAÇÃO JT FIXING KIT / KIT FIXATION	6
200819	PUXADOR SLIM XS - ESQUERDO LEFT HANDLE / POIGNEE GAUCHE	1
212085	CONJ. TOPOS JT93 JT93 END-CAPS KIT / KIT D'EMBOUS JT93	1
212221	CONJ. TAPA TOPOS KE71 KE71 END-CAPS KIT / KIT D'EMBOUS KE71	1
290052	PARAF DIN982 PH 3,5x16 A2 SCREW / VIS	1 + 4 un./m
290262	PARAFUSO PK INOX PH 1 1/2X10 CQ SCREW / VIS	8
218137	CALÇO REFORÇO HORIZONTAL JT * HORIZONTAL REINFORCEMENT SHIM / CALE DE RENFORCEMENT HORIZONTALE	2

\* Usar em folhas com vidros com peso superior a 80kg  
To be used in sashes which glass weight exceed 80kg / Utiliser dans des panneaux de verre d'un poids supérieur à 80 kg  
(a) Conforme esquemas de drenagem (Capítulo V - Maquinações)  
According to drainage schemes (Chapter V - Usinages)

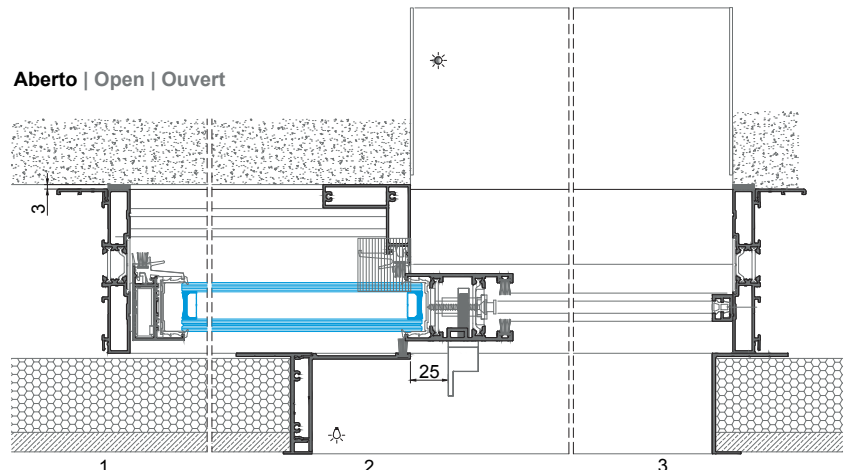
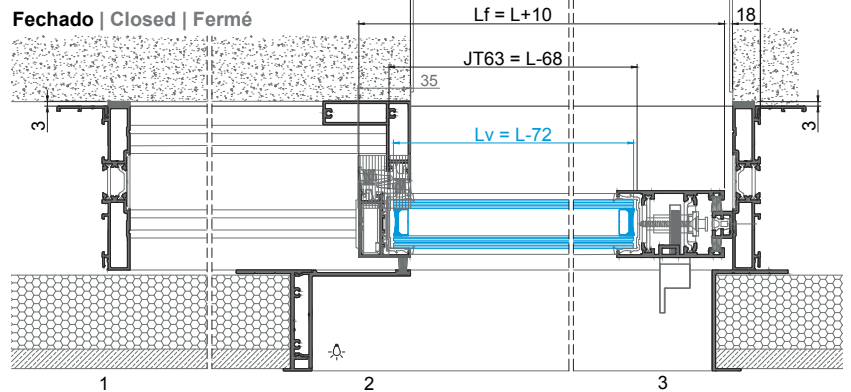
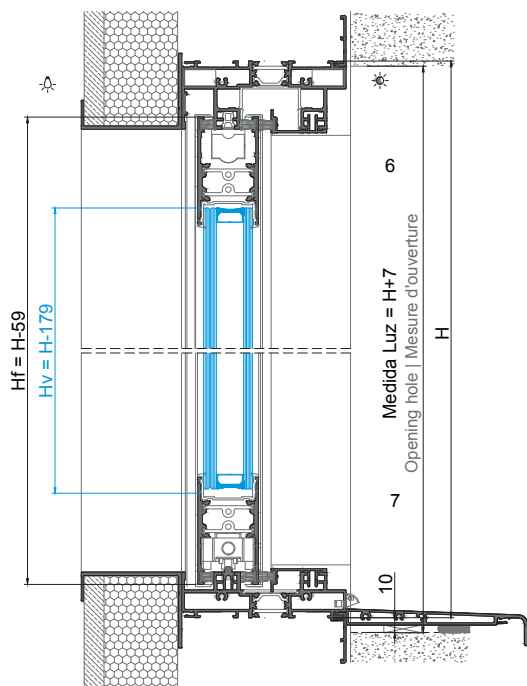
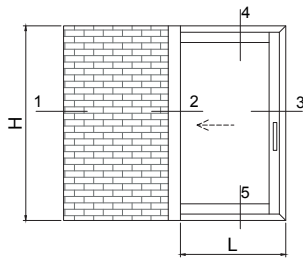

**JANELA DE CORRER 2 FOLHAS DE EMBUTIR 2-RAIL COM OMBREIRA JT18 CANTO 90° - LINHA SOLEIRA 30MM**  
2 SASHES POCKET 2-RAIL WITH JT18 JAMB SLIDING WINDOW 90° CORNER - 30MM SILL LINE  
FENÊTRE COULISSANT 2 VANTAOX À GALANDAGE 2-RAIL AVEC JAMBAGE JT18 À ANGLE 90° - LIGNE SEUIL 30MM

PERFIS   PROFILES   PROFILÉS					
CÓDIGO CODE / CODE	DESIGNAÇÃO DESIGNATION / NOMINATION	CORTE HORIZ. HORIZONTAL CUT COUPE HORIZ.	CORTE VERT. VERTICAL CUT COUPE VERTICALE	QUANT. QUANTITY QUANTITÉ	CORTE CUT COUPE
JT 12	PADEIRA INLET / LINTEAU	2L1-80 2L2-94	-	1	
JT 18	OMBREIRA JAMB / JAMBAGE	-	H	2	
JT 22	SOLEIRA SILL / SEUIL	2L1-80 2L2-94	-	1	
JT 51	PERFIL CENTRAL CENTRAL PROFILE / PROFILÉ CENTRAL	-	H-74	2	
JT 62	PERFIL LATERAL CANTO 90° 90° CORNER LAT. PR. / PR. LAT. D'ANGLE À 90°	-	H-74	2	
JT 63	TRAVESSA SUP/INF UP/LOW TRANSOM / TRAVERSE SUP/INF	L1-138 L2-150	-	2 2	
JT 72	PERFIL LIGAÇÃO CANTO 90° CORNER CONNECTION PROFILE / PROFILÉ DE LIAISON	-	H-143	1	
JT 92	CAPA COVER / CAPOT	L1-1 L2-1	-	2 2	
JT 87	GUIA GUIDE / GUIDE	2L1-199 2L2-213	-	1 1	
JT 93	PERFIL MONTANTE MULTIJOIN PROFILE / PROFILÉ DE MENEAU	-	H-38	2	
SO 46	PERFIL REMATE FINISHING PROFILE / PROFILÉ DE FINITION	-	H-90	2	
SO 47	PERFIL REMATE FINISHING PROFILE / PROFILÉ DE FINITION	-	H-90	2	
SO 48	PERFIL REMATE FINISHING PROFILE / PROFILÉ DE FINITION	L1-29 L2-29	-	2 2	
KE 71	PERFIL REMATE FINISHING PROFILE / PROFILÉ DE FINITION	L1+118 L2+118	-	1 1	
KE 60	PERFIL REMATE FINISHING PROFILE / PROFILÉ DE FINITION	(2xL1)-158 L1-115 (2xL2)-173 L2-129	H+60	1 1 1+2 1	
JE 96	PERFIL POLIAMIDA POLYAMIDE PROFILE / PROFILÉ DE POLYAMIDE	L1-138 L1-103 L2-172 L2-103	H	1 1 1+2 1	
208346	JUNTA CENTRAL 2196 CENTRAL JOINT / JOINT CENTRALE	-	H-59	4	
215305	PERFIL PVC U U PVC PROFILE / PROFILÉ PVC U	2L1-126 2L2-140	-	2 2	

VEDANTES   SEALS   JOINTS			
CÓDIGO CODE / CODE	DESIGNAÇÃO DESIGNATION / NOMINATION	QUANT. QUANTITY QUANTITÉ	
208348	JUNTA TAPA CANAL 2116 JT JOINT / JOINT	2L1 2L2	
208099	JUNTA VIDRO U 1032 CX 32MM JT GLAZING GASKET / JOINT DE VITRAGE	2L1, 4H 2L2*	
208307	PELUCIA 7x10 TRI-FIN PRETA FILE SEAL / JOINT BRUSSE	6L1, 9H 6L2	
208479	JUNTA TAPA CANAL PERFIL LIG. 2117 JT JOINT / JOINT	H	
208435	JUNTA VD 2415 JOINT / JOINT	H	
208466	PELUCIA 7x12 STOP-FIN PRETA FILE SEAL / JOINT BRUSSE	2H	

ACESSÓRIOS   ACCESSORIES   ACCESSOIRES		
CÓDIGO CODE / CODE	DESIGNAÇÃO DESIGNATION / NOMINATION	QUANT. QUANTITY QUANTITÉ
205129	CARRINHO JT 180KG ROLLER / ROULETTE	4
213286	CORTA-VENTO JT CENTRAL WATERPROOFING BRUSH / BRUSSE CENTRALE D'ÉTANCHÉITÉ	2
213287	CORTA-VENTO CANTO 90° JT 90° CORNER WATERPROOFING BRUSH / BRUSSE D'ÉTANCHÉITÉ ANGLE 90°	1
213288	CORTA-VENTO BAIXO JT LOW CENTRAL WATERPROOFING BRUSH / BRUSSE CENTRALE D'ÉTANCHÉITÉ BAS	5
223105	KIT JUNTAS ADESIVAS Nº1 JT KIT Nº2 ADHESIVE JOINTS KIT / KIT DE JOINTS ADHÉSIFS Nº2 JT	1
213246	CANTO CR S/SB CORNER / ANGLE	4
212243	CONJ. UNIÃO CANTO 90° JT 90° CORNER UNION KIT / KIT D'UNION ANGLE 90°	1
204389	ESQUADRO INOX CANTO 90° 90° STAINLESS STEEL CORNER / ANGLE EN ACIER INOXYDABLE 90°	1
212199	CONJ. TOPOS LAT. JT LATERAL END-CAPS KIT / KIT D'EMBOUITS LATÉRAUX	2
212230	CONJ. TOPOS INTERIOR LAT. JT LATERAL INNER END-CAPS KIT / KIT D'EMBOUITS INTÉRIEUR LATÉRAUX	1
212201	CONJ. TAMPAS TOPOS LAT. JT LATERAL END-CAP COVERS KIT / KIT DE COUVERTURE POUR EMBOUTS LATÉRAUX	1
212231	CONJ. TOPOS CENTRAIS JT CENTRAL END-CAPS KIT / KIT D'EMBOUITS CENTRAUX	2
212339	CONJ. TAMPAS TOPOS CENTRAIS JT CENTRAL END-CAP COVERS KIT / KIT DE COUVERTURE POUR EMBOUTS CENTRAUX	2
212109	CONJ. TOPOS CANTO 90° JT 90° CORNER END-CAPS KIT / KIT D'EMBOUITS POUR ANGLE 90°	1
210268	GOTEIRA C/ VALV. SVE OUTSIDE FLAP VALVE / CLAPE À VOLET EXTÉRIEUR	(a)
210285	GOTEIRA C/ VALV. BOLA PRT (OPCIONAL) BALL VALVE (OPTIONAL) / CLAPETS À BILLE (OPTIONNEL)	6
211223	FERRAGEM MULTIPONTO CENTR. 1000 MULTIPOINT HARDWARE / SERRURE MULTIPONTO	1
202491	CONTRA-FECHO ANTI-LEVANTAMENTO MULTIPONTO STRIKING PLATE / GÂCHE	2
212458	CONJ. FIX. CONTRA-FECHO MULTIP. 2F/90° JT MULTIPONTO HARDWARE STRIKING PLATE FIXING KIT / KIT FIXATION GÂCHE SERRURE MULTIP.	2
218154	CALÇO P/ C.-FECHO PERF. LIG CONNECTING PROFILE STRIKING PLATE SHIM / CALE POUR GÂCHE PROFILÉ DE LIAISON	2
218198	CALÇO P/ MULTIPONTO SÓS JT MULTIPONTO HARDWARE SHIM / CALE POUR MULTIPONTO	6
212162	CONJ. CENTRADOR P/ FERRAGEM JT PERFIL LIG. CENTERING KIT FOR JT HARDWARE / KIT CENTRAGE POUR SERRURE JT	1
212371	CONJ. FIXAÇÃO JT FIXING KIT / KIT FIXATION	6
212079	CONJ. FIX. FERRAGEM MULTIP. JT72 MULTIPONTO FIXING KIT / KIT FIXATION SERRURE MULTIPONTO	1 + 1 un./m (mn. 4)
200817	PUXADOR HANDLE XS - DIREITO RIGHT HANDLE / POIGNÉE DROITE	1
212085	CONJ. TOPOS JT93 JT93 END-CAPS KIT / KIT D'EMBOUITS JT93	2
212221	CONJ. TAPA TOPOS KE71 KIT END-CAPS KIT / KIT D'EMBOUITS KE71	1
290262	PARAFUSO PK INOX PH 1 1/2X10 CQ SCREW / VIS	16
218137	CALÇO REFORÇO HORIZONTAL JT * HORIZONTAL REINFORCEMENT SHIM / CALE DE RENFORCEMENT HORIZONTALE	4

\* Usar em folhas com vidros com peso superior a 80kg  
To be used in sashes which glass weight exceed 80kg / Utiliser dans des panneaux de verre d'un poids supérieur à 80 kg  
(a) Conforme esquemas de drenagem (Capítulo V - Maquinações)  
According to drainage schemes (Chapter V - Machinings) / Selon les schémas de drainage (Chapitre V - Usinages)

As fórmulas foram concebidas para medidas de vidros iguais.  
Nesta tipologia existem 2 larguras de folha distintas: Lf1 e Lf2.  
The formulas were designed for glasses with equal measures.  
In this typology there are 2 distinct sash widths: Lf1 and Lf2.  
Les formules sont conçues pour mesurer le verre. Dans cette typologie, il existe 2 largeurs de vantaux distinctes: Lf1 et Lf2.

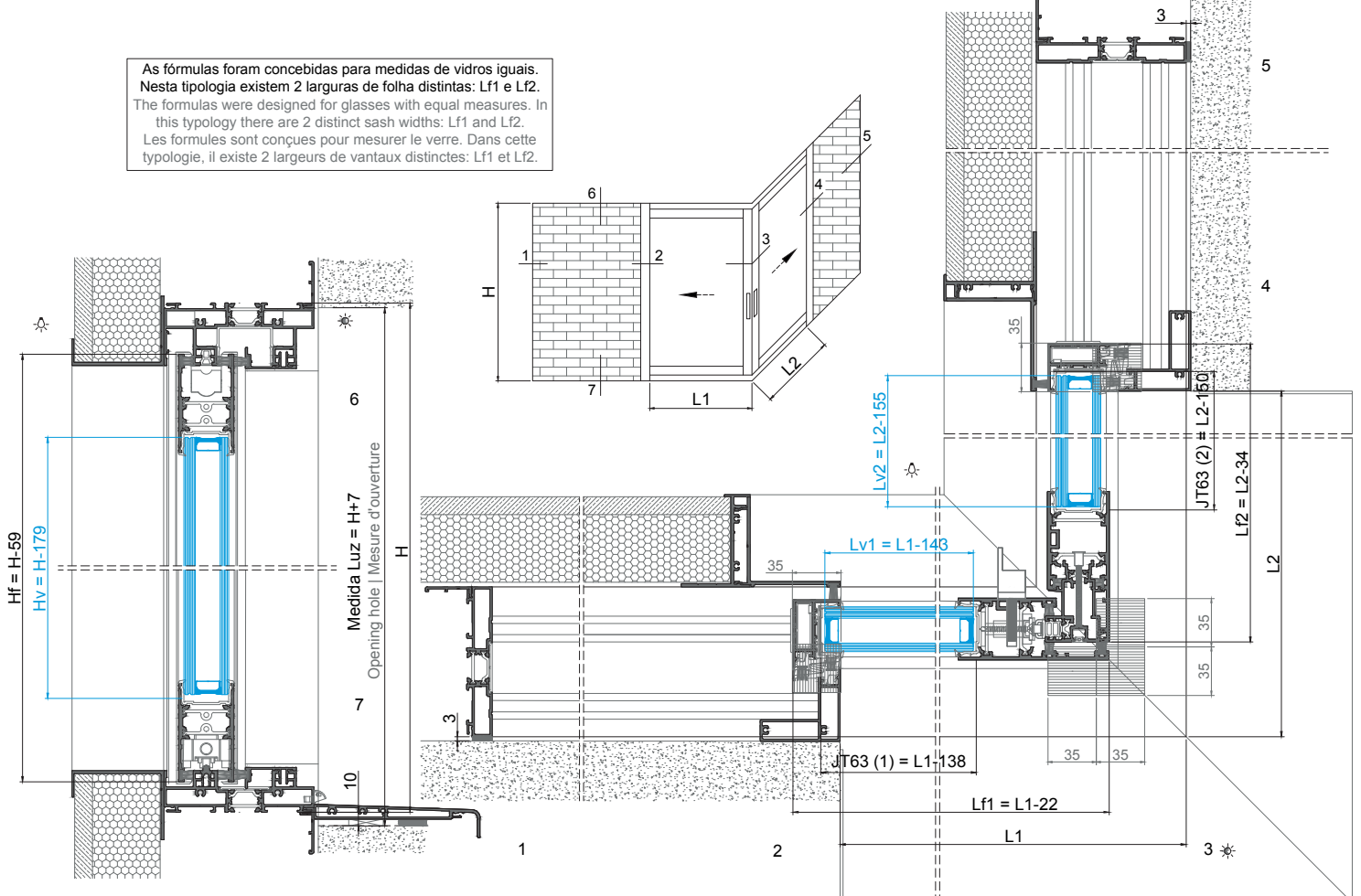



**JANELA DE CORRER 4 FOLHAS DE EMBUTIR 3RAIL COM OMBREIRA JT28 COM LIGAÇÃO CENTRAL - LINHA SOLEIRA 30MM**

4 SASHES POCKET 3-RAIL WITH JT28 JAMB SLIDING WINDOW WITH CENTRAL CONNECTION - 30MM SILL LINE

FENÊTRE COULISSANT 4 VANTAUX À GALANDAGE 3-RAIL AVEC JAMBAGE JT28 À GALANDAGE AVEC CONNEXION CENTRALE - LIGNE SEUIL 30MM

PERFIS   PROFILES   PROFILÉS					
CÓDIGO CODE / CODE	DESIGNAÇÃO DESIGNATION / NOMINATION	CORTE HORIZ. HORIZONTAL CUT COUPE HORIZ.	CORTE VERT. VERTICAL CUT COUPE VERTICALE	QUANT. QUANTITY QUANTITE	CORTE CUT COUPE
JT 13	PADIEIRA INTER.   L'INTEAU	(3L+62)/2	-	1	
JT 23	SOLEIRA SILL   SEUIL	(3L+62)/2	-	1	
JT 28	OMBREIRA JAMB   JAMBAGE	-	H	2	
JT 51	PERFIL CENTRAL CENTRAL PROFILE   PROFILÉ CENTRAL	-	H-59	4	
JT 53	PERFIL CENTRAL CENTRAL PROFILE   PROFILÉ CENTRAL	-	H-59	2	
JT 67	PERFIL LATERAL LATERAL PROFILE   PROFILÉ LATÉRAL	-	H-59	2	
JT 63	TRAVESSA SUP/INF WINDOW TRANSOM   TRAVERSE SUP/INF	(L-107)/4 (L-104)/4	-	4 4	
JT 71	PERFIL LIGAÇÃO CENTRAL CONNECTION PROFILE   PROFILÉ DE LIAISON	-	H-128	1	
JT 85	CAPA COVER   COUVERTURE	(L-75)/4	-	4	
JT 88	CAPA COVER   COUVERTURE	(L+70)/2	-	2	
JT 87	GUIA GUIDE   GUIDE	(3L+62)/2 (L-6)/2	-	1 2	
JT 93	PERFIL MONTANTE MULLION PROFILE   PROFILÉ DE MENEAU	-	H-38	2	
SO 46	PERFIL REMATE FINISHING PROFILE   PROFILÉ DE FINITION	-	H-75	2	
SO 47	PERFIL REMATE FINISHING PROFILE   PROFILÉ DE FINITION	-	H-75	2	
SO 48	PERFIL REMATE FINISHING PROFILE   PROFILÉ DE FINITION	L+158	-	2	
KE 71	PERFIL REMATE FINISHING PROFILE   PROFILÉ DE FINITION	L-6	-	1	
KE 60	PERFIL REMATE FINISHING PROFILE   PROFILÉ DE FINITION	(L+257)/4 (3L+259)/2	H+60	2 1 + 2	
JE 96	PERFIL POLIAMIDA POLYAMIDE PROFILE   PROFILÉ DE POLYAMIDE	L-9 (L-77)/2 (L+10)/4	H	2 1 + 4 2	
208346	JUNTA CENTRAL 2196 CENTRAL JOINT   JOINT CENTRALE	-	H-59	8	
215305	PERFIL PVC U U PVC PROFILE   PROFILÉ PVC U	(3L+62)/2	-	2	

ACESSÓRIOS   ACCESSORIES   ACCESSOIRES		
CÓDIGO CODE / CODE	DESIGNAÇÃO DESIGNATION / NOMINATION	QUANT. QUANTITY QUANTITE
205129	CARRINHO JT 180KG ROLLER   ROULETTE	8
213286	CORTA-VENTO JT CENTRAL WATERPROOFING BRUSH   BROSSE CENTRALE D'ÉTANCHÉITÉ	5
213288	CORTA-VENTO BAIXO JT LOW CENTRAL WATERPROOFING BRUSH   BROSSE CENTRALE D'ÉTANCHÉITÉ BAS	5
223106	KIT JUNTAS ADESIVAS Nº2 JT JT Nº2 ADHESIVE JOINTS KIT   KIT DE JOINTS ADHÉSIFS Nº2 JT	1
213246	CANTO CR S/SB CORNER   ANGLE	4
212199	CONJ. TOPOS LAT. JT LATERAL END-CAPS KIT   KIT D'EMBOUTS LATÉRAUX	2
212230	CONJ. TOPOS INTERIOR LAT. JT LATERAL INNER END-CAPS KIT   KIT D'EMBOUTS INTÉRIEUR LATÉRAUX	1
212201	CONJ. TAMPAS TOPOS LAT. JT LATERAL END-CAP COVERS KIT   KIT DE COUVERTURE POUR EMBOUTS LATÉRAUX	1
212231	CONJ. TOPOS CENTRAIS JT CENTRAL END-CAPS KIT   KIT D'EMBOUTS CENTRAUX	6
212339	CONJ. TAMPAS TOPOS CENTRAIS JT CENTRAL END-CAP COVERS KIT   KIT DE COUVERTURE POUR EMBOUTS CENTRAUX	6
210241	TOPO CENTRAL REFORÇADO 28MM 28MM CENTRAL REINFORCED END-CAPS KIT   KIT D'EMBOUTS CENTRAUX RENFORCÉ 28MM	4
212104	CONJ. TOPOS LIG. 2 FOLHAS JT 2 SASHES CONNECTING END-CAPS KIT   KIT D'EMBOUTS CONNEXION 2 VANTAUX	1
210268	GOTEIRA OCULTA C/ VALV. SVE OUTSIDE FLAP VALVE   CLAPE À VOLET EXTÉRIEUR	(a)
211223	FERRAGEM MULTIPONTO CENTR. 1000 MULTIPOINT HARDWARE STRIKING PLATE FIXING KIT   KIT FIXATION GÂCHE SERRURE MULTIP.	1
202491	CONTRA-FECHO ANTI-LEVANTAMENTO MULTIPONTO STRIKING PLATE   GÂCHE	2
212458	CONJ. FIX. CONTRA-FECHO MULTIP. 2F/90° JT MULTIPOINT HARDWARE STRIKING PLATE FIXING KIT   KIT FIXATION GÂCHE SERRURE MULTIP.	2
218154	CALÇO P/ C.-FECHO PERF. LIG. CONNECTING PROFILE STRIKING PLATE SHIM   CALE POUR GÂCHE PROFILÉ DE LIAISON	2
218198	CALÇO P/ MULTIPONTO SOS JT MULTIPOINT HARDWARE SHIM   CALE POUR MULTIPONTO	6
212162	CONJ. CENTRADOR P/ FERRAGEM JT PERFIL LIG. CENTERING KIT FOR JT HARDWARE   KIT CENTRAGE POUR SERRURE JT	1
212371	CONJ. FIXAÇÃO JT FIXING KIT   KIT FIXATION	6
212017	CONJ. FIX. FERRAGEM MULTIP. MULTIPOINT HARDWARE FIXING KIT   KIT FIXATION POUR SERRURE MULTIPONTO	1 + 1 un./m (min. 4)
200817	PUXADOR SLIM XS - DIREITO RIGHT HANDLE   POIGNÉE DROITE	1
200057	PUXADOR FOLHA PASSIVA SLIM XS PASSIVE SASH HANDLE   POIGNÉE VENTIL PASSIVE	1
212085	CONJ. TOPOS JT93 JT93 END-CAPS KIT   KIT D'EMBOUTS JT93	2
212221	CONJ. TAPA TOPOS KE71 KE71 END-CAPS KIT   KIT D'EMBOUTS KE71	1
290262	PARAFUSO PAR 003 PK INOX PH 1 1/2X10 CQ SCREW   VIS	32
290030	PARAFUSO DIN7981 4,2x38 INOX A2 SCREW   VIS	12
218137	CALÇO REFORÇO HORIZONTAL JT * HORIZONTAL REINFORCEMENT SHIM   CALE DE RENFORCEMENT HORIZONTALE	8

\* Usar em folhas com vidros com peso superior a 80kg  
To be used in sashes which glass weight exceed 80kg | Utiliser dans des panneaux de verre d'un poids supérieur à 80 kg  
(a) Conforme esquemas de drenagem (Capítulo V - Maquinações)  
According to drainage schemes (Chapter V - Machinings) | Selon les schémas de drainage (Chapitre V - Usinages)

VEDANTES   SEALS   JOINTS		
CÓDIGO CODE / CODE	DESIGNAÇÃO DESIGNATION / NOMINATION	QUANT. QUANTITY QUANTITE
208099	JUNTA VIDRO U 1032 CX 32MM JT GLAZING GASKET   JOINT DE VITRAGE	4L
208307	PELUCIA 7x10 TRI-FIN PRETA PILE SEAL   JOINT BROSSE	6L + 12H
208466	PELUCIA 7x12 STOP-FIN PRETA PILE SEAL   JOINT BROSSE	2H
208479	JUNTA TAPA CANAL PERFIL LIG. 2117 JT JOINT   JOINT	H

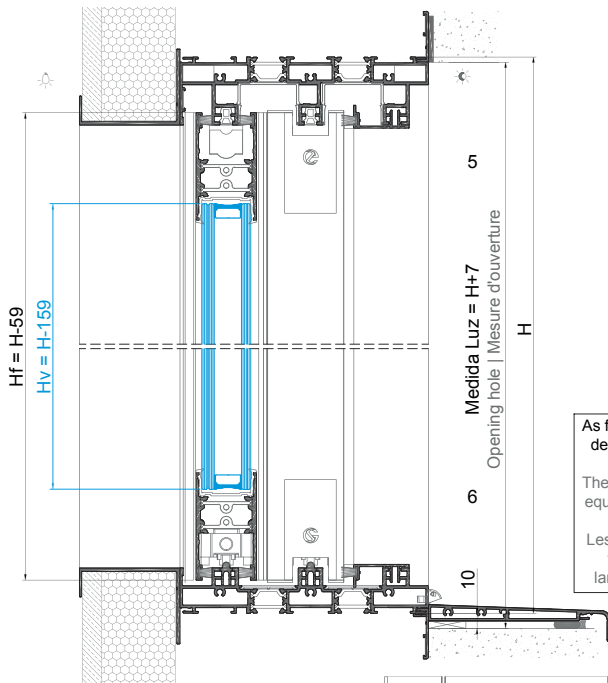

As fórmulas foram concebidas para medidas de vidros iguais. Nesta tipologia existem 2 larguras de folha distintas: Lf1 e Lf2.  
The formulas were designed for glasses with equal measures. In this typology there are 2 distinct sash widths: Lf1 and Lf2.  
Les formules sont conçues pour mesurer le verre. Dans cette typologie, il existe 2 largeurs de vantaux distinctes: Lf1 et Lf2.

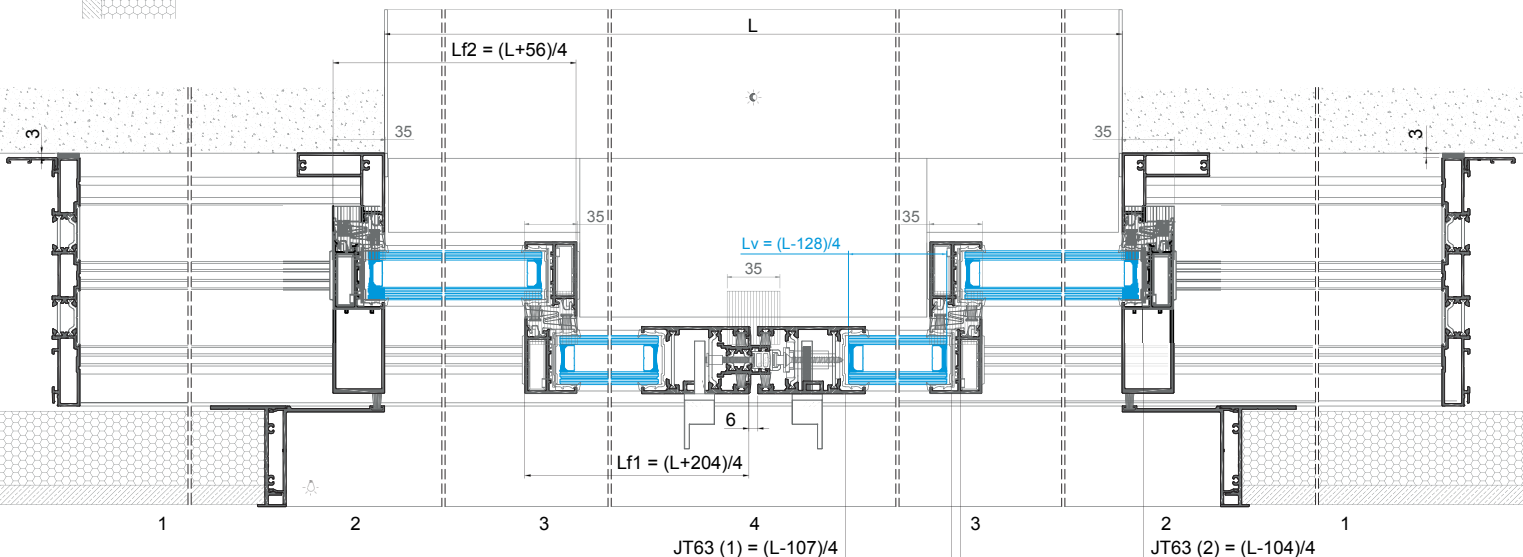
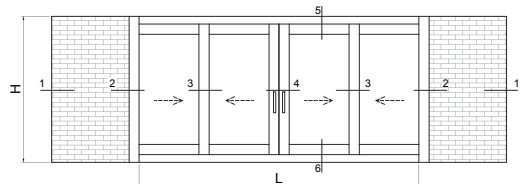



**JANELA DE CORRER 1 FOLHA + FIXO (ARO FIXO JT 15)**  
1 SASH + FIXED SLIDING WINDOW (JT 15 FIXED FRAME)  
FENÊTRE COULISSANT 1 VANTAIL + FIXE (DORMANT JT 15)

PERFIS   PROFILES   PROFILÉS					
CÓDIGO CODE   CODE	DESIGNAÇÃO DESIGNATION   NOMINATION	CORTE HORIZ. HORIZONTAL CUT COUPE HORIZ.	CORTE VERT. VERTICAL CUT COUPE VERTICALE	QUANT. QUANTITY QUANTITÉ	CORTE CUT COUPE
JT 15	ARO FIXO FIXED FRAME   CADRE DORMANT	L	H	2+2	
JT 54	PERFIL CENTRAL CENTRAL PROFILE   PROFILÉ CENTRAL	-	H-74	1	
JT 64	PERFIL LATERAL LATERAL PROFILE   PROFILÉ LATÉRAL	-	H-74	1	
JT 63	TRAVESSA SUP/INF UP/LW TRANSOM   TRAVERSE SUP/INF	L2-98	-	2	
JT 82	PERFIL PINGADEIRA DRIP PROFILE   L'ARMIER	L-4	-	1	
JT 89	CAPA COVER   CAPOT	L2-65	H-62	2 + 1	
JT 92	CAPA COVER   CAPOT	-	H-37	1	
JT 87	GUIA GUIDE   GUIDE	L-93	-	1	
JT 94	PERFIL MONTANTE MULLION PROFILE   PROFILÉ DE MENEAU	-	H-62	1	
JE 95	BITE GLAZING BEAD   PARCLOSE	L1-34	H-90	2+2	
208346	JUNTA CENTRAL 2196 CENTRAL JOINT   JOINT CENTRALE	-	H-74	1	
208349	JUNTA CENTRAL 2195 JT FIXO CENTRAL JOINT   JOINT CENTRALE	-	H-74	1	
215310	PERFIL PVC U JT FIXO U PVC PROFILE   PROFILÉ PVC U	L1-49 65 L2-49	H-32	2 2 + 2 2	

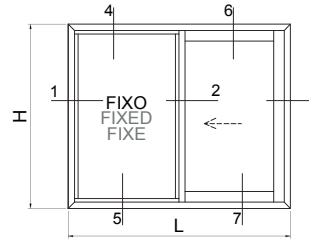

DESEMPENHO DO SISTEMA SYSTEM PERFORMANCE PERFORMANCE DU SYSTÈME	
Permeabilidade ao AR AIR Permeability Perméabilité à l'AIR	4
Estanteabilidade à ÁGUA WATER Tightness Étanchéité à l'EAU	7A
Resistência ao VENTO WIND Resistance Résistance au VENT	B3

ACESSÓRIOS   ACCESSORIES   ACCESSOIRES		
CÓDIGO CODE   CODE	DESIGNAÇÃO DESIGNATION   NOMINATION	QUANT. QUANTITY QUANTITÉ
205129	CARRINHO JT 180KG ROLLER   ROULETTE	2
213303	CORTA-VENTO JT FIXO CENTRAL WATERPROOFING BRUSH   BROSSSE CENTRALE D'ÉTANCHÉITÉ	2
212337	CONJ. ESTANQ. CORTA-VENTO JT CENTRAL WATERPROOFING BRUSH KIT   KIT BROSSSE CENTRALE D'ÉTANCHÉITÉ	1
204153	ESQUADRO JT 11x20,5 CORNER CLEAT   ÉQUERRE	8
212199	CONJ. TOPOS LAT. JT LATERAL END-CAPS KIT   KIT D'EMBOUITS LATÉRAUX	1
212230	CONJ. TOPOS INTERIOR LAT. JT LATERAL INNER END-CAPS KIT   KIT D'EMBOUITS INTÉRIEUR LATÉRAUX	1
212201	CONJ. TAMPAS TOPOS LAT. JT LATERAL END-CAP COVERS KIT   KIT DE COUVERTURE POUR EMBOUITS LATÉRAUX	1
210239	TOPO JT64/JT65 28MM 28MM FRSA/JT65 END-CAP   EMBOUT JT64/JT65 28MM	2
212231	CONJ. TOPOS CENTRAIS JT CENTRAL END-CAPS KIT   KIT D'EMBOUITS CENTRAUX	1
212339	CONJ. TAMPAS TOPOS CENTRAIS JT CENTRAL END-CAP COVERS KIT   KIT DE COUVERTURE POUR EMBOUITS CENTRAUX	1
210243	TOPO CENTRAL REFORÇADO JT54 28MM 28MM CENTRAL REINFORCED END-CAPS KIT   KIT D'EMBOUITS CENTRAUX REFORÇÉ 28MM	2
210268	GOTEIRA C/ VALV. SVE OUTSIDE FLAP VALVE   CLAPE À VOLET EXTÉRIEUR	(a)
210265	GOTEIRA C/ VALV. BOLA PRT BALL VALVE   CLAPE À BILLE	(a)
211237	FERRAGEM MULTIPONTO ALU MAE.1000 MULTIPOINT HARDWARE   SERRURE MULTIPONT	1
202330	CONTRA-FECHO ALU STRIKING PLATE   GÂCHE	2
212455	CONJ. FIX. CONTRA-FECHO AL MULTIP. JT MULTIPOINT HARDWARE STRIKING PLATE FIXING KIT   KIT FIXATION GÂCHE SERRURE MULTIPONT	2
212289	CONJ. CENTRADOR P/ FERRAGEM ALU CENTERING KIT FOR ALU HARDWARE   KIT CENTRAGE POUR SERRURE ALU	1
212371	CONJ. FIXAÇÃO JT FIXING KIT   KIT FIXATION	6
201382	FECHO DE EMBUTIR R2051X HANDLE   POIGNÉE	1
204717	GANCHO LIGAÇÃO. MULTIPONTO GMA HOOK   CROUCHET	1
212384	CONJ. TOPOS LAT. PINGADEIRA JT82 LATERAL DRIP END-CAPS KIT   KIT D'EMBOUITS LATÉRAUX POUR REJET D'EAU	2
228107	LIMITADOR ABERT. PQ SERIE CORRER SPRING LIMITER   LIMITEUR D'OUVRETURE	1
290262	PARAFUSO PK INOX PH 1 1/2x10 CQ SCREW   VIS	8
218137	CALÇO REFORÇO HORIZONTAL JT * HORIZONTAL REINFORCEMENT SHIM   CALE DE RENFORCEMENT HORIZONTALE	2
212087	CONJ. FIXAÇÃO JT 94 JT 94 FIXING KIT   KIT POUR FIXATION DU PROFILÉ JT 94	1 ou   or   ou
290030	PARAFUSO DIN7981 4,2x38 INOX A2 SCREW   VIS	4

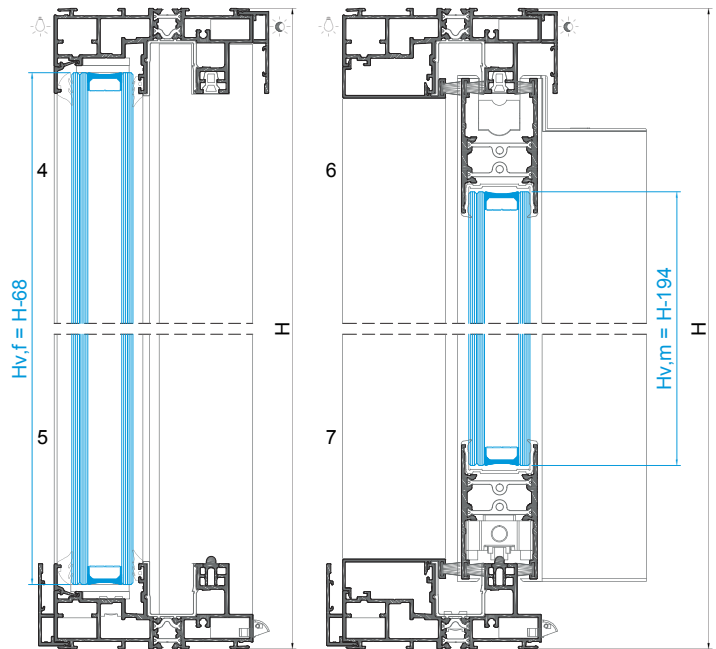

\* Usar em folhas com vidros com peso superior a 80kg  
To be used in sashes which glass weight exceed 80kg | Utiliser dans des panneaux de verre d'un poids supérieur à 80 kg  
(a) Conforme esquemas de drenagem (Capítulo V - Maquinações)  
According to drainage schemes (Chapter V - Machinings) | Selon les schémas de drainage (Chapitre V - Usinages)

VEDANTES   SEALS   JOINTS		
CÓDIGO CODE   CODE	DESIGNAÇÃO DESIGNATION   NOMINATION	QUANT. QUANTITY QUANTITÉ
208348	JUNTA TAPA CANAL 2116 JT JOINT   JOINT	1L + 1H
208099	JUNTA VIDRO U 1032 CX 32MM JT GLAZING GASKET   JOINT DE VITRAGE	1L + 2H
208307	PELUCIA 7x10 TRI-FIN PRETA PILE SEAL   JOINT BRUSSE	3L + 6H
208350	JUNTA EXTERIOR 2003 JOINT   JOINT	(2xL1) + 2H
	JUNTA INTERIOR CUNHA JOINT   JOINT	(2xL1) + 2H

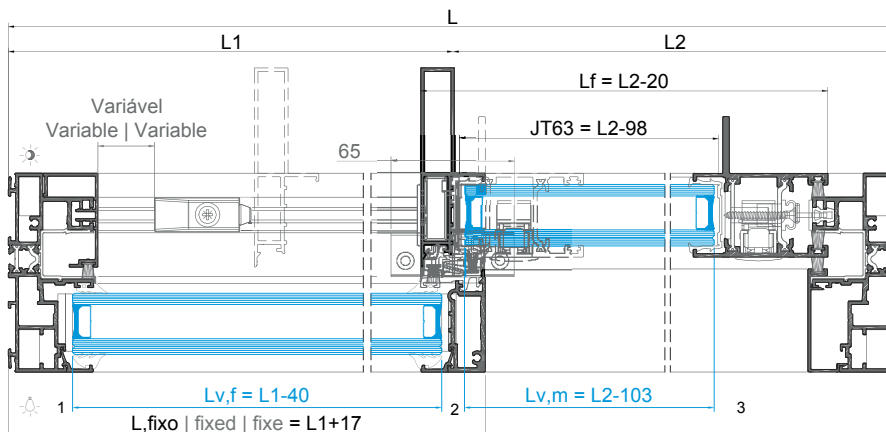

**JANELA DE CORRER 2 FOLHAS + FIXO (ARO FIXO JT 15)**  
2 SASHES + FIXED SLIDING WINDOW (JT 15 FIXED FRAME)  
FENÊTRE COULISSANT 2 VANTAOX + FIXE (DORMANT JT 15)

PERFIS   PROFILES   PROFILÉS					
CÓDIGO CODE   CODE	DESIGNAÇÃO DESIGNATION   NOMINATION	CORTE HORIZ. HORIZONTAL CUT COUPE HORIZ.	CORTE VERT. VERTICAL CUT COUPE VERTICALE	QUANT. QUANTITY QUANTITÉ	CORTE CUT COUPE
JT 15	ARO FIXO FIXED FRAME   CADRE DORMANT	L	H	2+2	
JT 54	PERFIL CENTRAL CENTRAL PROFILE   PROFILÉ CENTRAL	-	H-74	2	
JT 64	PERFIL LATERAL LATERAL PROFILE   PROFILÉ LATÉRAL	-	H-74	2	
JT 63	TRAVESSA SUP/INF UP/DOWN TRANSOM   TRAVERSE SUP/INF	L2-98 L3-98	-	2	
JT 82	PERFIL PINGADEIRA DRIP PROFILE   L'ARMIER	L-4	-	1	
JT 89	CAPA COVER   CAPOT	L2-65 L3-65	H-62	2 + 2	
JT 87	GUIA GUIDE   GUIDE	L-93	-	1	
JT 94	PERFIL MONTANTE MULLION PROFILE   PROFILÉ DE MENEAU	-	H-62	2	
JE 95	BITE GLAZING BEAD   PARCLOSE	L1-6	H-90	2 + 2	
208346	JUNTA CENTRAL 2196 CENTRAL JOINT JOINT CENTRALE	-	H-74	2	
208349	JUNTA CENTRAL 2195 JT FIXO CENTRAL JOINT JOINT CENTRALE	-	H-74	2	
215310	PERFIL PVC U JT FIXO U PVC PROFILE   PROFILÉ PVC U	L1-65 L2-49 L3-49 65	H-32	2 2 + 2 4	

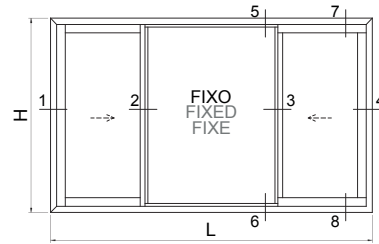

ACESSÓRIOS   ACCESSORIES   ACCESSOIRES			
CÓDIGO CODE   CODE	DESIGNAÇÃO DESIGNATION   NOMINATION	QUANT. QUANTITY QUANTITÉ	
205129	CARRINHO JT 180KG ROLLER   ROULETTE	4	
213303	CORTA-VENTO JT FIXO CENTRAL WATERPROOFING BRUSH   BROSSSE CENTRALE D'ETANCHÉITÉ	4	
212337	CONJ. ESTANQ. CORTA-VENTO JT CENTRAL WATERPROOFING BRUSH KIT   KIT BROSSSE CENTRALE D'ETANCHÉITÉ	2	
204153	ESQUADRO JT 11x20,5 CORNER CLEAT   EQUERRE	8	
212199	CONJ. TOPOS LAT. JT LATERAL END-CAPS KIT   KIT D'EMBOUITS LATÉRAUX	2	
212230	CONJ. TOPOS INTERIOR LAT. JT LATERAL INNER END-CAPS KIT   KIT D'EMBOUITS INTÉRIEUR LATÉRAUX	2	
212201	CONJ. TAMPAS TOPOS LAT. JT LATERAL END-CAP COVERS KIT   KIT DE COUVERTURE POUR EMBOUTS LATÉRAUX	2	
210239	TOPO JT64/JT65 28MM 28MM JT64/JT65 END-CAP EMBOUT JT64/JT65 28MM	4	
212231	CONJ. TOPOS CENTRAIS JT CENTRAL END-CAPS KIT   KIT D'EMBOUITS CENTRAUX	2	
212339	CONJ. TAMPAS TOPOS CENTRAIS JT CENTRAL END-CAP COVERS KIT   KIT DE COUVERTURE POUR EMBOUTS CENTRAUX	2	
210243	TOPO CENTRAL REFORÇADO JT54 28MM 28MM CENTRAL REINFORCED END-CAPS KIT   KIT D'EMBOUITS CENTRAUX RENFORCÉ 28MM	4	
210268	GOTEIRA C/ VALV. SVE OUTSIDE FLAP VALVE   CLAPE À VOILET EXTERIEUR	(a)	
210265	GOTEIRA C/ VALV. BOLA PRT BALL VALVE   CLAPE À BILLE	(a)	
211237	FERRAGEM MULTIPONTO ALU MAE.1000 MULTIPOINT HARDWARE   SERRURE MULTIPOINT	2	
202330	CONTRA-FECHO ALU STRIKING PLATE   GÂCHE	4	
212455	CONJ. FIX. CONTRA-FECHO AL MULTIP. JT MULTIPOINT HARDWARE STRIKING PLATE FIXING KIT   KIT FIXATION GÂCHE SERRURE MULTIPOINT	4	
212289	CONJ. CENTRADOR P/ FERRAGEM ALU CENTERING KIT FOR ALU HARDWARE   KIT CENTRAGE POUR SERRURE ALU	2	
212371	CONJ. FIXAÇÃO JT FIXING KIT   KIT FIXATION	12	
201382	FECHO DE EMBUTIR R20511X HANDLE   POIGNÉE	2	
204717	GANCHO LIGAÇÃO. MULTIPONTO GMA HOOK   CROUCHET	2	
212384	CONJ. TOPOS LAT. PINGADEIRA JT82 LATERAL DRIP END-CAPS KIT   KIT D'EMBOUITS LATÉRAUX POUR REJET D'EAU	2	
228107	LIMITADOR ABERT. PQ SERIE CORRER OPENING LIMITER   LIMITEUR D'OUVERTURE	2	
290262	PARAFUSO PK INOX PH 1 1/2x10 CQ SCREW   IVS	16	
218137	CALÇO REFORÇO HORIZONTAL JT * HORIZONTAL REINFORCEMENT SHIM   CALE DE RENFORCEMENT HORIZONTALE	4	
212087	CONJ. FIXAÇÃO JT 94 JT 94 FIXING KIT   KIT POUR FIXATION DU PROFILÉ JT 94	2 ou 07 ou 8	
290030	PARAFUSO DIN7981 4,2x38 INOX A2 SCREW   IVS	8	

\* Usar em folhas com vidros com peso superior a 80kg  
To be used in sashes with glass weight exceed 80kg | Utiliser dans des panneaux de verre d'un poids supérieur à 80 kg  
(a) Conforme esquemas de drenagem (Capítulo V - Maquinações)  
According to drainage schemes (Chapter V - Machinings) | Selon les schémas de drainage (Chapitre V - Usinages)

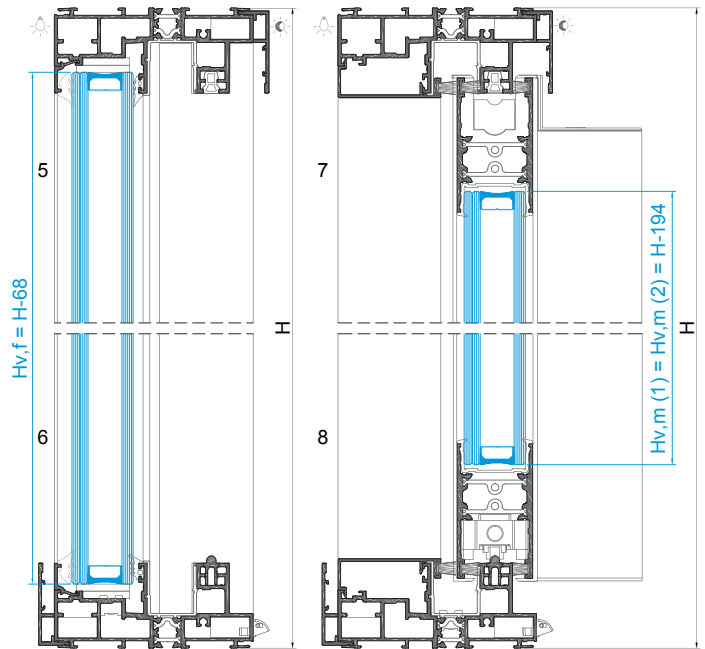

VEDANTES   SEALS   JOINTS		
CÓDIGO CODE   CODE	DESIGNAÇÃO DESIGNATION   NOMINATION	QUANT. QUANTITY QUANTITÉ
208348	JUNTA TAPA CANAL 2116 JT JOINT   JOINT	1L + 2H
208099	JUNTA VIDRO U 1032 CX 32MM JT GLAZING GASKET   JOINT DE VITRAGE	1L + 4H
208307	PELUCIA 7x10 TRI-FIN PRETA FILE SEAL   JOINT BRUSSE	3L + 10H
208350	JUNTA EXTERIOR 2003 JOINT   JOINT	(2x L2) + 2H
	JUNTA INTERIOR CUNHA JOINT   JOINT	(2x L2) + 2H

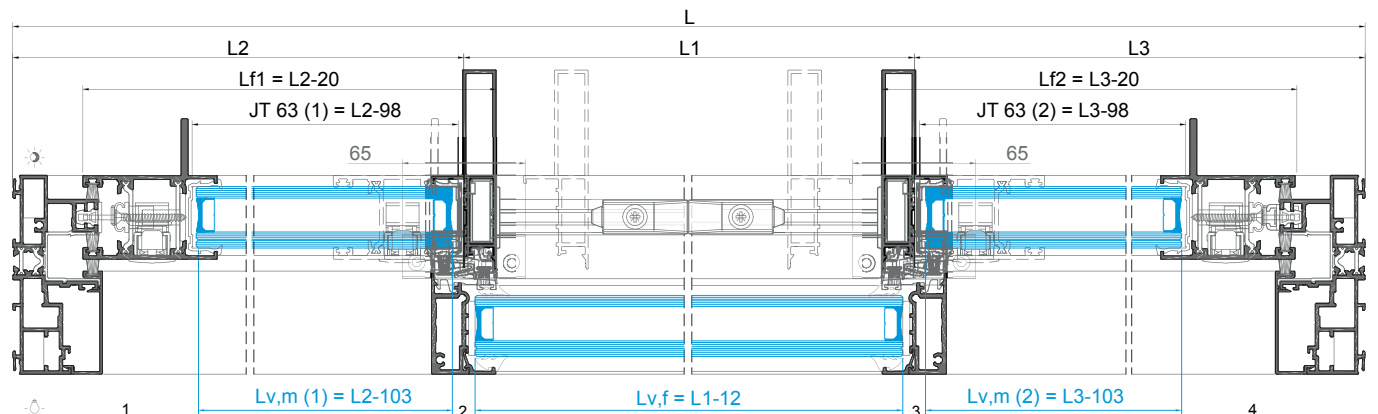

**JANELA DE CORRER 2 FOLHAS + FIXO (ARO FIXO JT 25)**  
2 SASHES + FIXED SLIDING WINDOW (JT 25 FIXED FRAME)  
FENÊTRE COULISSANT 2 VANTAUX + FIXE (DORMANT JT 25)

PERFIS   PROFILES   PROFILÉS					
CÓDIGO CODE   CODE	DESIGNAÇÃO DESIGNATION   NOMINATION	CORTE HORIZ. HORIZONTAL CUT COUPE HORIZ.	CORTE VERT. VERTICAL CUT COUPE VERTICALE	QUANT. QUANTITY QUANTITE	CORTE CUT COUPE
JT 25	ARO FIXO FIXED FRAME   CADRE DORMANT	L	H	2+2	
JT 54	PERFIL CENTRAL CENTRAL PROFILE   PROFILÉ CENTRAL	-	H-74	3	
JT 64	PERFIL LATERAL LATERAL PROFILE   PROFILÉ LATÉRAL	-	H-74	1	
JT 63	TRAVESSA SUP/INF UP/DOWN TRANSOM   TRAVERSE SUP/INF	L2-6 L3-98	-	2 2	
JT 82	PERFIL PINGADEIRA DRIP PROFILE   LARMIER	L-4	-	1	
JT 89	CAPA COVER   CAPOT	L2+L3-65	H-62	2 + 1	
JT 91	CAPA COVER   CAPOT	L3-66	H-51	2 + 2	
JT 92	CAPA COVER   CAPOT	-	H-37	1	
JT 87	GUIA GUIDE   GUIDE	L-93 L1+L2-31	-	1 1	
JT 94	PERFIL MONTANTE MULLION PROFILE   PROFILÉ DE MENEAU	-	H-62	1	
JE 95	BITE GLAZING BEAD   PARCLOSE	L1-34	H-90	2 + 2	
208346	JUNTA CENTRAL 2196 CENTRAL JOINT   JOINT CENTRALE	-	H-74	3	
208349	JUNTA CENTRAL 2195 JT FIXO CENTRAL JOINT   JOINT CENTRALE	-	H-74	1	
215305	PERFIL PVC U U PVC PROFILE   PROFILÉ PVC U	L-34 L1-49	H-34	2 + 2	
215310	PERFIL PVC U JT FIXO U PVC PROFILE   PROFILÉ PVC U	L2+L3-49 65	H-32	2 2	

VEDANTES   SEALS   JOINTS		
CÓDIGO CODE   CODE	DESIGNAÇÃO DESIGNATION   NOMINATION	QUANT. QUANTITY QUANTITE
208348	JUNTA TAPA CANAL 2116 JT JOINT   JOINT	2L + 1H
208099	JUNTA VIDRO U 1032 CX 32MM JT GLAZING GASKET   JOINT DE VITRAGE	2L + 4H
208307	PELUCIA 7x10 TRI-FIN PRETA FILE SEAL   JOINT BROISSE	3L + 8H
208350	JUNTA EXTERIOR 2003 JOINT   JOINT	(2x L1) + 2H
	JUNTA INTERIOR CUNHA JOINT   JOINT	(2x L1) + 2H

ACESSÓRIOS   ACCESSORIES   ACCESSOIRES		
CÓDIGO CODE   CODE	DESIGNAÇÃO DESIGNATION   NOMINATION	QUANT. QUANTITY QUANTITE
205129	CARRINHO JT 180KG ROLLER   ROULETTE	4
213286	CORTA-VENTO JT CENTRAL WATERPROOFING BRUSH   BROSSE CENTRALE D'ÉTANCHÉITÉ	2
213303	CORTA-VENTO JT FIXO CENTRAL WATERPROOFING BRUSH   BROSSE CENTRALE D'ÉTANCHÉITÉ	2
212337	CONJ. ESTANQ. CORTA-VENTO JT CENTRAL WATERPROOFING BRUSH KIT   KIT BROSSE CENTRALE D'ÉTANCHÉITÉ	2
204153	ESQUADRO JT 11x20,5 CORNER GLEAT   ÉQUERRE	8
212199	CONJ. TOPOS LAT. JT LATERAL END-CAPS KIT   KIT D'EMBOUITS LATÉRAUX	1
212230	CONJ. TOPOS INTERIOR LAT. JT LATERAL INNER END-CAPS KIT   KIT D'EMBOUITS INTÉRIEUR LATÉRAUX	1
212201	CONJ. TAMPAS TOPOS LAT. JT LATERAL END-CAP COVERS KIT   KIT DE COUVERTURE POUR EMBOUITS LATÉRAUX	1
210239	TOPO JT64/JT65 28MM 28MM JT64/JT65 END-CAP   EMBOUT JT64/JT65 28MM	2
212231	CONJ. TOPOS CENTRAIS JT CENTRAL END-CAPS KIT   KIT D'EMBOUITS CENTRAUX	3
212339	CONJ. TAMPAS TOPOS CENTRAIS JT CENTRAL END-CAP COVERS KIT   KIT DE COUVERTURE POUR EMBOUITS CENTRAUX	3
210243	TOPO CENTRAL REFORÇADO JT54 28MM 28MM CENTRAL REINFORCED END-CAPS KIT   KIT D'EMBOUITS CENTRAUX RENFORCÉ 28MM	6
210268	GOTEIRA C/ VALV. SVE OUTSIDE FLAP VALVE   CLAPE À VOLET EXTÉRIEUR	(a)
210265	GOTEIRA C/ VALV. BOLA PRT BALL VALVE   CLAPE À BILLE	(a)
211237	FERRAGEM MULTIPONTO ALU MAE 1000 MULTIPOINT HARDWARE   SERRURE MULTIPONTO	1
202330	CONTRA-FECHO ALU STRIKING PLATE   GÂCHE	2
212455	CONJ. FIX. CONTRA-FECHO AL MULTIP. JT MULTIPOINT HARDWARE STRIKING PLATE FIXING KIT   KIT FIXATION GÂCHE SERRURE MULTIPONTO	2
212289	CONJ. CENTRADOR P/ FERRAGEM ALU CENTERING KIT FOR ALU HARDWARE   KIT CENTRAGE POUR SERRURE ALU	1
212371	CONJ. FIXAÇÃO JT FIXING KIT   KIT FIXATION	6
201382	FECHO DE EMBUTIR R20511X HANDLE   POIGNEE	1
204717	GANCHO LIGAÇÃO. MULTIPONTO GMA	1
212384	CONJ. TOPOS LAT. PINGADEIRA JT82 LATERAL DRIP END-CAPS KIT   KIT D'EMBOUITS LATÉRAUX POUR REJET D'EAU	2
228107	LIMITADOR ABERT. PQ SERIE CORRER OPENING LIMITER   LIMITEUR D'OUVERTURE	1
290262	PARAFUO PK INOX PH 1 1/2X10 CQ SCREW / VIS	16
218137	CALÇO REFORÇO HORIZONTAL JT * HORIZONTAL REINFORCEMENT SHIM   CALE DE RENFORCEMENT HORIZONTALE	4
212087	CONJ. FIXAÇÃO JT 94 JT 94 FIXING KIT   KIT POUR FIXATION DU PROFILÉ JT 94	1
290030	PARAFUO DIN7981 4,2x38 INOX A2 SCREW / VIS	1 ou 1 or 1 4

\* Usar em folhas com vidros com peso superior a 80kg | To be used in sashes which glass weight exceed 80kg | Utiliser dans des panneaux de verre d'un poids supérieur à 80 kg  
(a) Conforme esquemas de drenagem (Capítulo V - Maquinações) | According to drainage schemes (Chapter V - Machinings) | Selon les schémas de drainage (Chapitre V - Usinages)

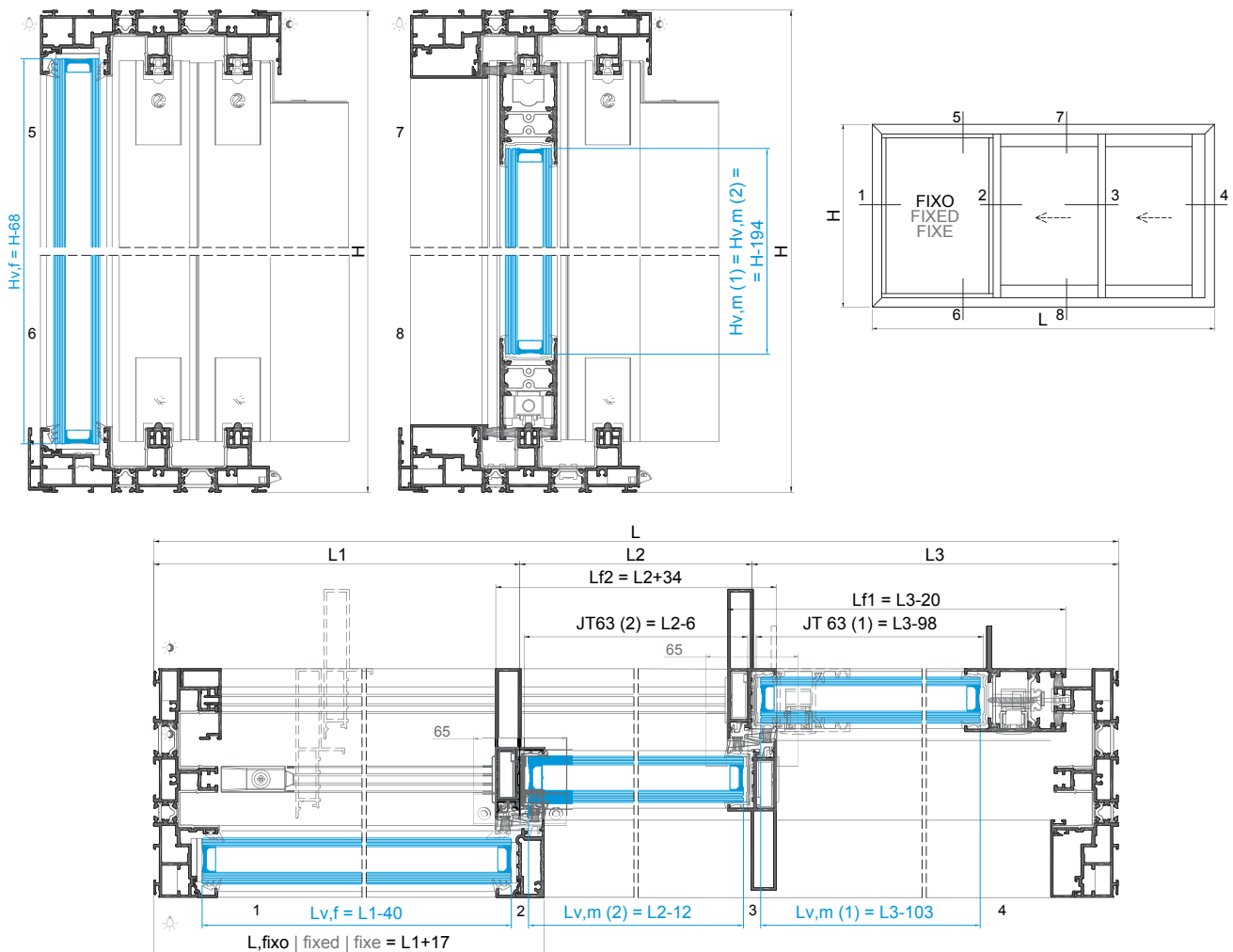

**JANELA DE CORRER 2 FOLHAS COM LIGAÇÃO CENTRAL + 2 FIXOS (ARO FIXO JT 15) - PUXADOR EMBUTIDO**  
2 SLIDING SASHES WITH CENTRAL CONNECTION + 2 FIXED WINDOW (JT 15 FIXED FRAME)  
FENÊTRE COULISSANT 2 VANTAUX AVEC CONNEXION CENTRALE + 2 FIXES (DORMANT JT 15)

PERFIS   PROFILES   PROFILÉS					
CÓDIGO CODE   CODE	DESIGNAÇÃO DESIGNATION   NOMINATION	CORTE HORIZ. HORIZONTAL CUT COUPE HORIZ.	CORTE VERT. VERTICAL CUT COUPE VERTICALE	QUANT. QUANTITY QUANTITE	CORTE CUT COUPE
JT 15	ARO FIXO FIXED FRAME   CADRE DORMANT	L	H	2 + 2	
JT 54	PERFIL CENTRAL CENTRAL PROFILE   PROFILÉ CENTRAL	-	H-74	2	
JT 67	PERFIL LATERAL LATERAL PROFILE   PROFILÉ LATÉRAL	-	H-74	2	
JT 63	TRAVESSA SUP/INF UP/LW TRANSOM   TRAVERSE SUP/INF	(L2-127)/2	-	4	
JT 71	PERFIL LIGAÇÃO CENTRAL CONNECTION PROFILE   PROFILÉ DE LIAISON	-	H-143	1	
JT 82	PERFIL PINGADEIRA DRIP PROFILE   L'ARMIER	L-4	-	1	
JT 89	CAPA COVER   CAPOT	L2-34	H-62	2 + 2	
JT 87	GUIA GUIDE   GUIDE	L-96	-	1	
JT 94	PERFIL MONTANTE MULLION PROFILE   PROFILÉ DE MENEAU	-	H-62	2	
JE 95	BITE GLAZING BEAD   PARCLOSE	L1-34 L3-34	H-90	2 + 4	
208346	JUNTA CENTRAL 2196 CENTRAL JOINT   JOINT CENTRALE	-	H-74	2	
208349	JUNTA CENTRAL 2195 JT FIXO CENTRAL JOINT   JOINT CENTRALE	-	H-74	2	
215310	PERFIL PVC U JT FIXO U PVC PROFILE   PROFILÉ PVC U	L1-49 (L2-130)/2 L3-49 65	H-33	2 4 + 2 6	

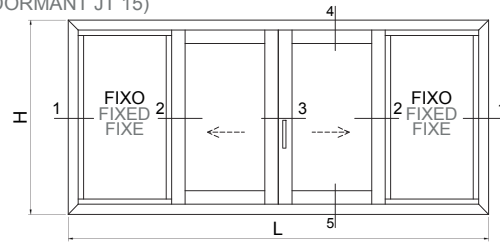

ACESSÓRIOS   ACCESSORIES   ACCESSOIRES			
CÓDIGO CODE   CODE	DESIGNAÇÃO DESIGNATION   NOMINATION		QUANT. QUANTITY QUANTITE
205129	CARRINHO JT 180KG ROLLER   ROULETTE		4
213303	CORTA-VENTO JT FIXO CENTRAL WATERPROOFING BRUSH   BRASSE CENTRALE D'ÉTANCHÉITÉ		6
212337	CONJ. ESTANQ. CORTA-VENTO JT CENTRAL WATERPROOFING BRUSH KIT   KIT BRASSE CENTRALE D'ÉTANCHÉITÉ		3
204153	ESQUADRO JT 11x20.5 CORNER GLAZING   ÉQUIERRE		8
212199	CONJ. TOPOS LAT. JT LATERAL END-CAPS KIT   KIT D'EMBOUTS LATÉRAUX		2
212230	CONJ. TOPOS INTERIOR LAT. JT LATERAL INNER END-CAPS KIT   KIT D'EMBOUTS INTÉRIEUR LATÉRAUX		2
212201	CONJ. TAMPAS TOPOS LAT. JT LATERAL END-CAP COVERS KIT   KIT DE COUVERTURE POUR EMBOUTS LATÉRAUX		2
212231	CONJ. TOPOS CENTRAIS JT CENTRAL END-CAPS KIT   KIT D'EMBOUTS CENTRAUX		2
212339	CONJ. TAMPAS TOPOS CENTRAIS JT CENTRAL END-CAP COVERS KIT   KIT DE COUVERTURE POUR EMBOUTS CENTRAUX		2
210243	TOPO CENTRAL REFORÇADO JT54 28MM 28MM CENTRAL REINFORCED END-CAPS KIT   KIT D'EMBOUTS CENTRAUX REINFORCÉ 28MM		4
212104	CONJ. TOPOS LIG. 2 FOLHAS JT 2 SASHES CONNECTING END-CAPS KIT   KIT D'EMBOUTS CONNEXION 2 VENTAUX		1
210268	GOTEIRA C/ VALV. SVE OUTSIDE FLAP VALVE   CLAPE À VOLET EXTERIEUR		(a)
210265	GOTEIRA C/ VALV. BOLA PRT BALL VALVE   CLAPE À BILLE		(a)
211237	FERRAGEM MULTIPONTO ALU MAE-1000 MULTIPOINT HARDWARE   SERRURE MULTIPONTO		1
202330	CONTRA-FECHO ALU STRIKING PLATE   GÂCHE		2
212458	CONJ. FIX. CONTRA-FECHO MULTIP. 2F/90° JT MULTIPOINT HARDWARE STRIKING PLATE FIXING KIT   KIT FIXATION GÂCHE SERRURE MULTIP.		2
212291	CONJ. CENTRADOR P/ FERRAGEM ALU PERFIL LIG. CENTRING KIT FOR ALU HARDWARE   KIT CENTRAGE POUR SERRURE ALU		1
212371	CONJ. FIXAÇÃO JT FIXING KIT   KIT FIXATION		6
212017	CONJ. FIX. FERRAGEM MULTIP. MULTIPOINT HARDWARE FIXING KIT   KIT FIXATION POUR SERRURE MULTIPONTO		1 + 1 un./m (min. 4)
201382	FECHO DE EMBUTIR R20511X HANDLE   POIGNÉE		1
204717	GANCHO LIGAÇÃO. MULTIPONTO GMA HOOK   CROCHET		1
218211	CONCHA R2043 FLUSH HANDLE   POIGNÉE CUVETTE		1
212384	CONJ. TOPOS LAT. PINGADEIRA JT82 LATERAL DRIP END-CAPS KIT   KIT D'EMBOUTS LATÉRAUX POUR REJET D'EAU		2
228107	LIMITADOR ABERT. PQ SERIE CORRER OPENING LIMITER   LIMITEUR D'OUVERTURE		2
290262	PARAFUSO PK INOX PH 1 1/2x10 CQ SCREW   VIS		16
218137	CALÇO REFORÇO HORIZONTAL JT * HORIZONTAL REINFORCEMENT SHIM   CALE DE RENFORCEMENT HORIZONTALE		4
212087	CONJ. FIXAÇÃO JT 94 JT 94 FIXING KIT   KIT POUR FIXATION DU PROFILÉ JT 94		2 ou   or   ou
290030	PARAFUSO DIN7981 4,2x38 INOX A2 SCREW   VIS		8

\* Usar em folhas com vidros com peso superior a 80kg  
To be used in sashes which glass weight exceed 80kg | Utiliser dans des panneaux de verre d'un poids supérieur à 80 kg  
(a) Conforme esquemas de drenagem (Capítulo V - Maquinações)  
According to drainage schemes (Chapter V - Machinings) | Selon les schémas de drainage (Chapitre V - Usinages)

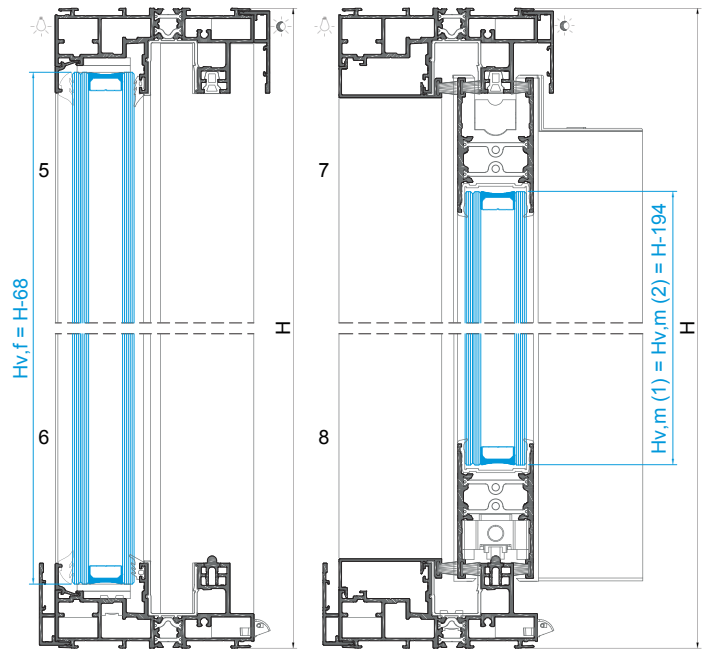

VEDANTES   SEALS   JOINTS		
CÓDIGO CODE   CODE	DESIGNAÇÃO DESIGNATION   NOMINATION	QUANT. QUANTITY QUANTITE
208348	JUNTA TAPA CANAL 2116 JT JOINT   JOINT	1L
208099	JUNTA VIDRO U 1032 CX 32MM JT GLAZING GASKET   JOINT DE IVRAGE	1L + 4H
208307	PELUCIA 7x10 TRI-FIN PRETA PILE SEAL   JOINT BRASSE	6L + 10H
208350	JUNTA EXTERIOR 2003 JOINT   JOINT	(2xL2) + 2H
	JUNTA INTERIOR CUNHA JOINT   JOINT	(2xL2) + 2H
208479	JUNTA TAPA CANAL PERFIL LIG. 2117 JT JOINT   JOINT	H

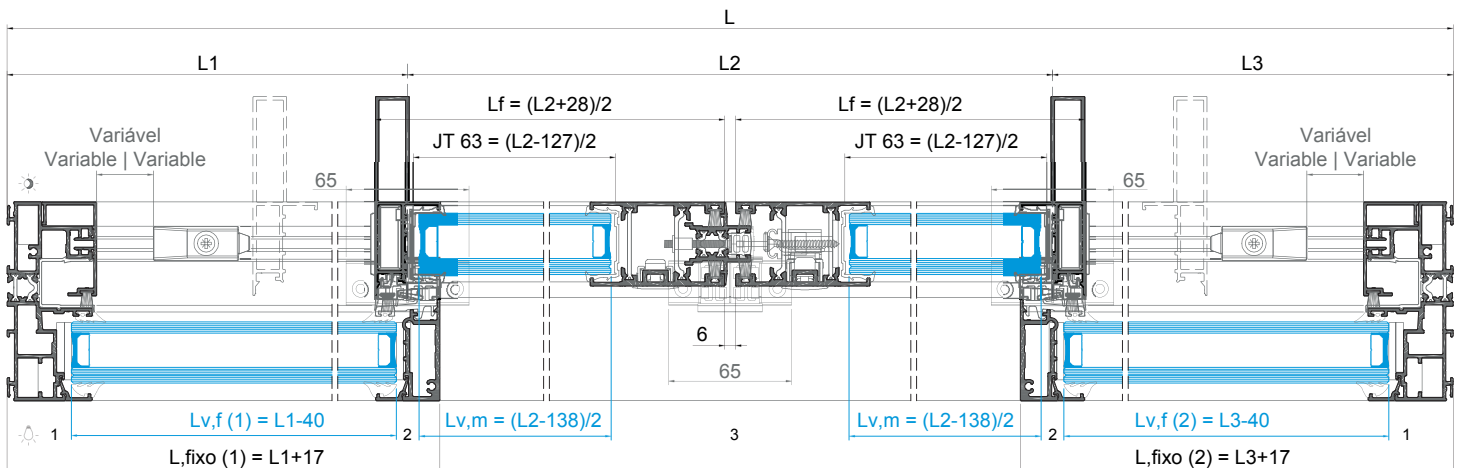



**JANELA DE CORRER 2 FOLHAS COM LIGAÇÃO CENTRAL + 2 FIXOS (ARO FIXO JT 15) - PUXADOR SLIM XS**  
2 SLIDING SASHES WITH CENTRAL CONNECTION + 2 FIXED WINDOW (JT 15 FIXED FRAME)  
FENÊTRE COULISSANT 2 VANTAOX AVEC CONNEXION CENTRALE + 2 FIXES (DORMANT JT 15)

PERFIS   PROFILES   PROFILÉS					
CÓDIGO CODE   CODE	DESIGNAÇÃO DESIGNATION   NOMINATION	CORTE HORIZ. HORIZONTAL CUT COUPE HORIZ.	CORTE VERT. VERTICAL CUT COUPE VERTICALE	QUANT. QUANTITY QUANTITE	CORTE CUT COUPE
JT 15	ARO FIXO FIXED FRAME   CADRE DORMANT	L	H	2 + 2	
JT 54	PERFIL CENTRAL CENTRAL PROFILE   PROFILÉ CENTRAL	-	H-74	2	
JT 67	PERFIL LATERAL LATERAL PROFILE   PROFILÉ LATÉRAL	-	H-74	2	
JT 63	TRAVESSA SUP/INF UP/LW TRANSOM   TRAVERSE SUP/INF	(L2-127)/2	-	4	
JT 71	PERFIL LIGAÇÃO CENTRAL CONNECTION PROFILE   PROFILÉ DE LIAISON	-	H-143	1	
JT 82	PERFIL PINGADEIRA DRIP PROFILE   L'ARMIER	L-4	-	1	
JT 89	CAPA COVER   CAPOT	L2-34	H-62	2 + 2	
JT 87	GUIA GUIDE   GUIDE	L-96	-	1	
JT 94	PERFIL MONTANTE MULLION PROFILE   PROFILÉ DE MENEAU	-	H-62	2	
JE 95	BITE GLAZING BEAD   PARCLOSE	L1-34 L3-34	H-90	2 + 4	
208346	JUNTA CENTRAL 2196 CENTRAL JOINT   JOINT CENTRALE	-	H-74	2	
208349	JUNTA CENTRAL 2195 JT FIXO CENTRAL JOINT   JOINT CENTRALE	-	H-74	2	
215310	PERFIL PVC U JT FIXO U PVC PROFILE   PROFILÉ PVC U	L1-49 (L2-130)/2 L3-49 65	H-33	2 4 2 + 2 6	

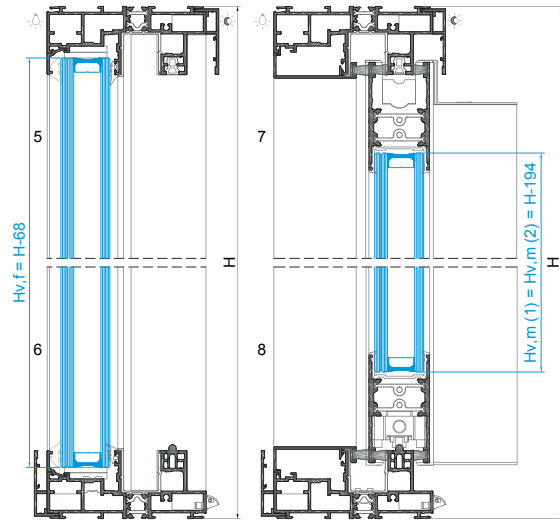
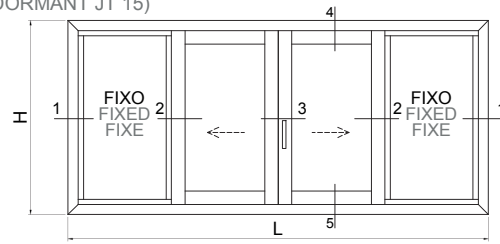

ACESSÓRIOS   ACCESSORIES   ACCESSOIRES		
CÓDIGO CODE   CODE	DESIGNAÇÃO DESIGNATION   NOMINATION	QUANT. QUANTITY QUANTITE
205129	CARRINHO JT 180KG ROLLER   ROULETTE	4
213303	CORTA-VENTO JT FIXO CENTRAL WATERPROOFING BRUSH   BROSSA CENTRALE D'ETANCHÉITE	6
212337	CONJ. ESTANQ. CORTA-VENTO JT CENTRAL WATERPROOFING BRUSH KIT   KIT BROSSA CENTRALE D'ETANCHÉITE	3
204153	ESQUADRO JT 11x20.5 CORNER CLEAT   EQUERRE	8
212199	CONJ. TOPOS LAT. JT LATERAL END-CAPS KIT   KIT D'EMBOUITS LATÉRAUX	2
212230	CONJ. TOPOS INTERIOR LAT. JT LATERAL INNER END-CAPS KIT   KIT D'EMBOUITS INTÉRIEUR LATÉRAUX	2
212201	CONJ. TAMPAS TOPOS LAT. JT LATERAL END-CAP COVERS KIT   KIT DE COUVERTURE POUR EMBOUTS LATÉRAUX	2
212231	CONJ. TOPOS CENTRAIS JT CENTRAL END-CAPS KIT   KIT D'EMBOUITS CENTRAUX	2
212339	CONJ. TAMPAS TOPOS CENTRAIS JT CENTRAL END-CAP COVERS KIT   KIT DE COUVERTURE POUR EMBOUTS CENTRAUX	2
210243	TOPO CENTRAL REFORÇADO JT54 28MM 28MM CENTRAL REINFORCED END-CAPS KIT   KIT D'EMBOUITS CENTRAUX RENFORCÉ 28MM	4
212104	CONJ. TOPOS LIG. 2 FOLHAS JT 2 SASHES CONNECTING END-CAPS KIT   KIT D'EMBOUITS CONNEXION 2 VANTAOX	1
210268	GOTEIRA C/ VALV. SVE OUTSIDE FLAP VALVE   CLAPE À VOLET EXTÉRIEUR	(a)
210265	GOTEIRA C/ VALV. BOLA PRT BALL VALVE   CLAPE À BILLE	(a)
211223	FERRAGEM MULTIPONTO CENTR. 1000 MULTIPOINT HARDWARE   SERRURE MULTIPONTO	1
202491	CONTRA-FECHO ANTI-LEVANTAMENTO MULTIPONTO STRIKING PLATE GÂCHE	2
202487	CENTRADOR JT P/ C-FECHO AL MULTIPONTO JT CENTERING FOR STRIKING PLATE   CENTRAGE JT POUR GÂCHE	4
212458	CONJ. FIX. CONTRA-FECHO MULTIP. 2F/90° JT MULTIPOINT HARDWARE STRIKING PLATE FIXING KIT   KIT FIXATION GÂCHE SERRURE MULTIP.	2
218154	CALÇO P/ C-FECHO PERF. LIG CONNECTING PROFILE STRIKING PLATE SHIM   CALE POUR GÂCHE PROFILÉ DE LIASION	2
218198	CALÇO P/ MULTIPONTO SOS JT MULTIPOINT HARDWARE SHIM   CALE POUR MULTIPONTO	12
212162	CONJ. CENTRADOR P/ FERRAGEM JT PERFIL LIG. CENTERING KIT FOR JT HARDWARE   KIT CENTRAGE POUR SERRURE JT	1
212371	CONJ. FIXAÇÃO JT FIXING KIT   KIT FIXATION	12
212017	CONJ. FIX. FERRAGEM MULTIP. MULTIPOINT HARDWARE FIXING KIT   KIT FIXATION POUR SERRURE MULTIPONTO	1 + 1 un./m (min. 4)
200817	PUXADOR SLIM XS - DIREITO RIGHT HANDLE   POIGNEE DROITE	1
200057	PUXADOR FOLHA PASSIVA SLIM XS PASSIVE SASH HANDLE   POIGNEE VENTAIL PASSIVE	1
212384	CONJ. TOPOS LAT. PINGADEIRA JT82 LATERAL DRIP END-CAPS KIT   KIT D'EMBOUITS LATÉRAUX POUR REJET D'EAU	1
228107	LIMITADOR ABERT. PQ SERIE CORRER OPENING LIMITER   LIMITEUR D'OUVERTURE	2
290262	PARAFUSO PK INOX PH 1 1/2X10 CQ SCREW   VIS	16
218137	CALÇO REFORÇO HORIZONTAL JT * HORIZONTAL REINFORCEMENT SHIM   CALE DE RENFORCEMENT HORIZONTALE	4
212087	CONJ. FIXAÇÃO JT 94 JT 94 FIXING KIT   KIT POUR FIXATION DU PROFILÉ JT 94	2
290030	PARAFUSO DIN7981 4.2x38 INOX A2 SCREW   VIS	ou 1   ou 8

VEDANTES   SEALS   JOINTS		
CÓDIGO CODE   CODE	DESIGNAÇÃO DESIGNATION   NOMINATION	QUANT. QUANTITY QUANTITE
208348	JUNTA TAPA CANAL 2116 JT JOINT   JOINT	1L
208099	JUNTA VIDRO U 1032 CX 32MM JT GLAZING GASKET   JOINT DE VITRAGE	1L + 4H
208307	PELUCIA 7x10 TRI-FIN PRETA PILE SEAL   JOINT BRUSSE	6L + 10H
208350	JUNTA EXTERIOR 2003 JOINT   JOINT	(2xL2) + 2H
	JUNTA INTERIOR CUNHA JOINT   JOINT	(2xL2) + 2H
208479	JUNTA TAPA CANAL PERFIL LIG. 2117 JT JOINT   JOINT	H

**Nota | Note | Remarque:**  
Todas as medidas horizontais foram calculadas considerando a abertura e posicionamento do limitador conforme representado.  
All horizontal measurements were calculated considering the opening and positioning of the limiter as shown.  
Toutes les mesures horizontales ont été calculées en tenant compte de l'ouverture et du positionnement du limiteur comme indiqué.

\* Usar em folhas com vidros com peso superior a 80kg  
To be used in sashes with glass weight exceed 80kg | Utiliser dans des panneaux de verre d'un poids supérieur à 80 kg  
(a) Conforme esquemas de drenagem (Capítulo V - Maquinações)  
According to drainage schemes (Chapter V - Machinings) | Selon les schémas de drainage (Chapitre V - Usinages)

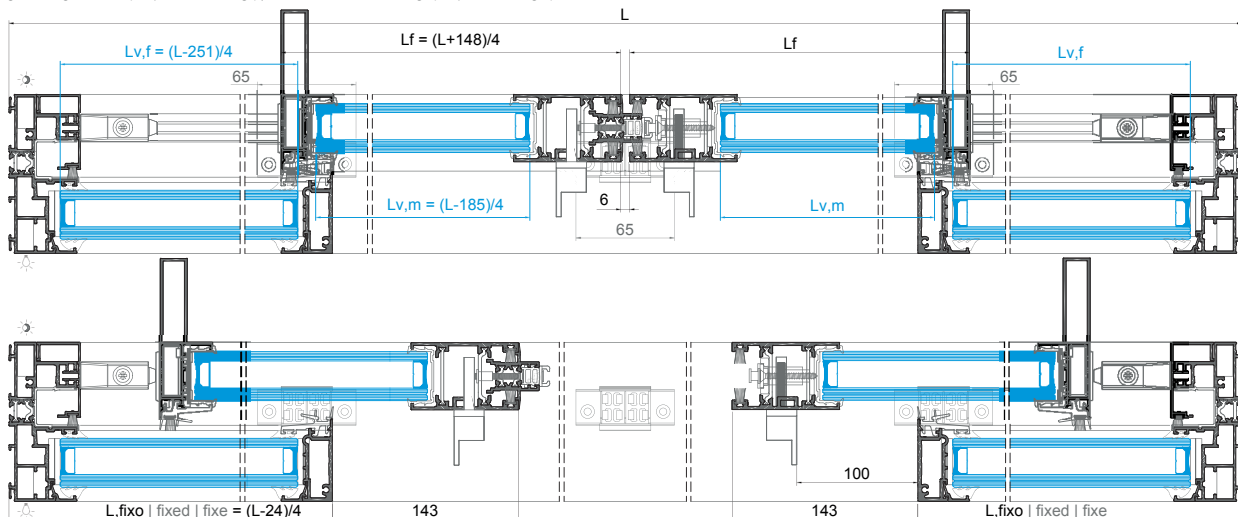

**JANELA DE CORRER 1 FOLHA + FIXO (ARO FIXO JT 16)**  
1 SASH + FIXED SLIDING WINDOW (JT 16 FIXED FRAME)  
FENÊTRE COULISSANT 1 VANTAIL + FIXE (DORMANT JT 16)

PERFIS   PROFILES   PROFILÉS					
CÓDIGO CODE   CODE	DESIGNAÇÃO DESIGNATION   NOMINATION	CORTE HORIZ. HORIZONTAL CUT COUPE HORIZ.	CORTE VERT. VERTICAL CUT COUPE VERTICALE	QUANT. QUANTITY QUANTITÉ	CORTE CUT COUPE
JT 16	ARO FIXO FIXED FRAME   CADRE DORMANT	L	H	2+2	
JT 54	PERFIL CENTRAL CENTRAL PROFILE   PROFILÉ CENTRAL	-	H-74	1	
JT 64	PERFIL LATERAL LATERAL PROFILE   PROFILÉ LATÉRAL	-	H-74	1	
JT 63	TRAVESSA SUP/INF UP/DW TRANSOM   TRAVERSE SUP/INF	L2-98	-	2	
JT 82	PERFIL PINGADEIRA DRIP PROFILE   L'ARMIER	L-4	-	1	
JT 89	CAPA COVER   CAPOT	L2-65	H-62	2 + 1	
JT 90	CAPA COVER   CAPOT	-	H-37	1	
JT 87	GUIA GUIDE   GUIDE	L-93	-	1	
JT 94	PERFIL MONTANTE MULLION PROFILE   PROFILÉ DE MENEAU	-	H-62	1	
JE 95	BITE GLAZING BEAD   PARCLOSE	L1-34	H-90	2+2	
208346	JUNTA CENTRAL 2196 CENTRAL JOINT   JOINT CENTRALE	-	H-74	1	
208349	JUNTA CENTRAL 2195 JT FIXO CENTRAL JOINT   JOINT CENTRALE	-	H-74	1	
215310	PERFIL PVC U JT FIXO U PVC PROFILE   PROFILÉ PVC U	L1-49 65 L2-49	H-32	2 2 + 2 2	

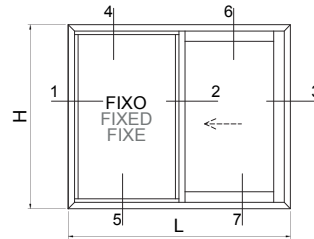

DESEMPENHO DO SISTEMA SYSTEM PERFORMANCE PERFORMANCE DU SYSTÈME	
Permeabilidade ao AR AIR Permeability Perméabilité à l'AIR	4
Estanteidade à ÁGUA WATER Tightness Étanchéité à l'EAU	7A
Resistência ao VENTO WIND Resistance Résistance au VENT	B4 <sup>(a)</sup>   C3 <sup>(b)</sup>

<sup>(a)</sup> Ensaio 1; <sup>(b)</sup> Ensaio 2 | <sup>(a)</sup> Test 1; <sup>(b)</sup> Test 2 | <sup>(a)</sup> Essai 1; <sup>(b)</sup> Essai 2

ACESSÓRIOS   ACCESSORIES   ACCESSOIRES			
CÓDIGO CODE   CODE	DESIGNAÇÃO DESIGNATION   NOMINATION	QUANT. QUANTITY QUANTITÉ	
205129	CARRINHO JT 180KG ROLLER   ROULETTE	2	
213303	CORTA-VENTO JT FIXO CENTRAL WATERPROOFING BRUSH   BROSSSE CENTRALE D'ÉTANCHÉITÉ	2	
212337	CONJ. ESTANQ. CORTA-VENTO JT CENTRAL WATERPROOFING BRUSH KIT   KIT BROSSSE CENTRALE D'ÉTANCHÉITÉ	1	
204153	ESQUADRO JT 11x20.5 CORNER CLEAT   EQUERRE	8	
213246	CANTO CR S/SB CORNER   ANGLE	4	
212199	CONJ. TOPOS LAT. JT LATERAL END-CAPS KIT   KIT D'EMBOUITS LATÉRAUX	1	
212230	CONJ. TOPOS INTERIOR LAT. JT LATERAL INNER END-CAPS KIT   KIT D'EMBOUITS INTÉRIEUR LATÉRAUX	1	
212201	CONJ. TAMPAS TOPOS LAT. JT LATERAL END-CAP COVERS KIT   KIT DE COUVERTURE POUR EMBOUITS LATÉRAUX	1	
210239	TOPO JT64/JT65 28MM 28MM JT64/JT65 END-CAP   EMBOUT JT64/JT65 28MM	2	
212231	CONJ. TOPOS CENTRAIS JT CENTRAL END-CAPS KIT   KIT D'EMBOUITS CENTRAUX	1	
212339	CONJ. TAMPAS TOPOS CENTRAIS JT CENTRAL END-CAP COVERS KIT   KIT DE COUVERTURE POUR EMBOUITS CENTRAUX	1	
210243	TOPO CENTRAL REFORÇADO JT54 28MM 28MM CENTRAL REINFORCED END-CAPS KIT   KIT D'EMBOUITS CENTRAUX RENFORCÉ 28MM	2	
210268	GOTEIRA C/ VALV. SVE OUTSIDE FLAP VALVE   CLAPE À VOLET EXTÉRIEUR	(a)	
210265	GOTEIRA C/ VALV. BOLA PRT BALL VALVE   CLAPE À BILLE	(a)	
211237	FERRAGEM MULTIPONTO ALU MAE-1000 MULTIPOINT HARDWARE   SERRURE MULTIPONT	1	
202330	CONTRA-FECHO ALU STRIKING PLATE   GÂCHE	2	
212455	CONJ. FIX. CONTRA-FECHO AL MULTIP. JT MULTIPOINT HARDWARE STRIKING PLATE FIXING KIT   KIT FIXATION GÂCHE SERRURE MULTIPONT	2	
212289	CONJ. CENTRADOR P/ FERRAGEM ALU CENTRING KIT FOR ALU HARDWARE   KIT CENTRAGE POUR SERRURE ALU	1	
212371	CONJ. FIXAÇÃO JT FIXING KIT   KIT FIXATION	6	
201382	FECHO DE EMBUTIR R20511X HANDLE   POIGNÉE	1	
204717	GANCHO LIGAÇÃO. MULTIPONTO GMA HOOK   CROUCHET	1	
212384	CONJ. TOPOS LAT. PINGADEIRA JT82 LATERAL DRIP END-CAPS KIT   KIT D'EMBOUITS LATÉRAUX POUR REJET D'EAU	1	
228107	LIMITADOR ABERT. PQ SERIE CORRER OPENING LIMITER   LIMITEUR D'OUVRETURE	1	
290262	PARAFUSO PK INOX PH 1 1/2X10 CQ SCREW   VIS	8	
218137	CALÇO REFORÇO HORIZONTAL JT * HORIZONTAL REINFORCEMENT SHIM   CALE DE RENFORCEMENT HORIZONTALE	2	
212087	CONJ. FIXAÇÃO JT 94 JT 94 FIXING KIT   KIT POUR FIXATION DU PROFILÉ JT 94	ou   1   ou	
290030	PARAFUSO DIN7981 4.2x38 INOX A2 SCREW   VIS	4	

\* Usar em folhas com vidros com peso superior a 80kg  
To be used in sashes with glass weight exceed 80kg | Utiliser dans des panneaux de verre d'un poids supérieur à 80 kg  
(a) Conforme esquemas de drenagem (Capítulo V - Maquinações)  
According to drainage schemes (Chapter V - Machinings) | Selon les schémas de drainage (Chapitre V - Usinages)

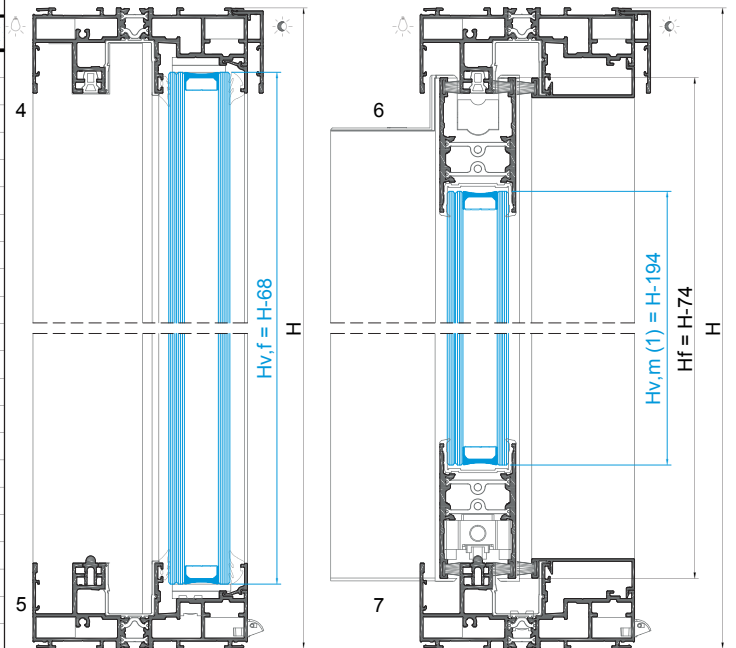

VEDANTES   SEALS   JOINTS		
CÓDIGO CODE   CODE	DESIGNAÇÃO DESIGNATION   NOMINATION	QUANT. QUANTITY QUANTITÉ
208348	JUNTA TAPA CANAL 2116 JT JOINT   JOINT	1L + 1H
208099	JUNTA VIDRO U 1032 CX 32MM JT GLAZING GASKET   JOINT DE IVTRAGE	1L + 2H
208307	PELUCIA 7x10 TRI-FIN PRETA PILE SEAL   JOINT BRUSSE	3L + 6H
208350	JUNTA EXTERIOR 2003 JOINT   JOINT	(2xL1) + 2H
	JUNTA INTERIOR CUNHA JOINT   JOINT	(2xL1) + 2H

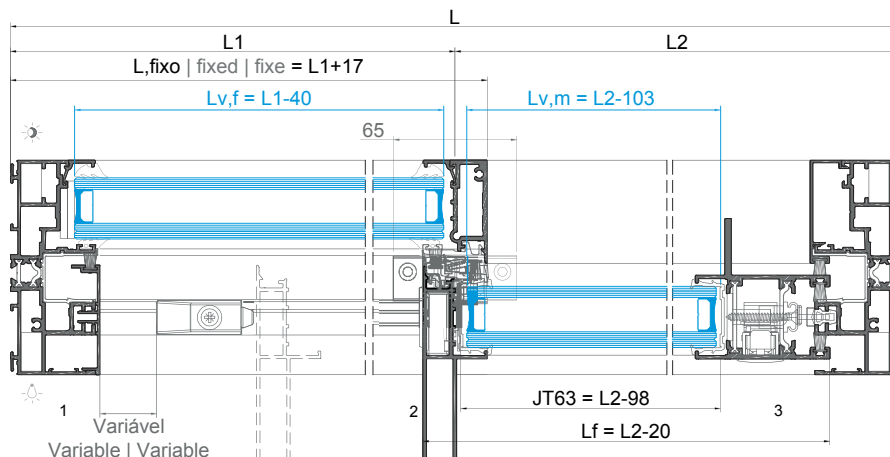

**JANELA DE CORRER 2 FOLHAS + FIXO (ARO FIXO JT 16)**  
2 SASHES + FIXED SLIDING WINDOW (JT 16 FIXED FRAME)  
FENÊTRE COULISSANT 2 VANTAUX + FIXE (DORMANT JT 16)

PERFIS   PROFILES   PROFILÉS					
CÓDIGO CODE   CODE	DESIGNAÇÃO DESIGNATION   NOMINATION	CORTE HORIZ. HORIZONTAL CUT COUPE HORIZ.	CORTE VERT. VERTICAL CUT COUPE VERTICALE	QUANT. QUANTITY QUANTITE	CORTE CUT COUPE
JT 16	ARO FIXO FIXED FRAME   CADRE DORMANT	L	H	2+2	
JT 54	PERFIL CENTRAL CENTRAL PROFILE   PROFILÉ CENTRAL	-	H-74	2	
JT 64	PERFIL LATERAL LATERAL PROFILE   PROFILÉ LATÉRAL	-	H-74	2	
JT 63	TRAVESSA SUP/INF UP/DW TRANSOM   TRAVERSE SUP/INF	L2-98 L3-98	-	2 2	
JT 82	PERFIL PINGADEIRA DRIP PROFILE   L'ARMIER	L-4	-	1	
JT 89	CAPA COVER   CAPOT	L2-65 L3-65	H-62	2+2	
JT 87	GUIA GUIDE   GUIDE	L-93	-	1	
JT 94	PERFIL MONTANTE MULLION PROFILE   PROFILÉ DE MENEAU	-	H-62	2	
JE 95	BITE GLAZING BEAD   PARCLOSE	L1-6	H-90	2+2	
208346	JUNTA CENTRAL 2196 CENTRAL JOINT   JOINT CENTRALE	-	H-74	2	
208349	JUNTA CENTRAL 2165 JT FIXO CENTRAL JOINT   JOINT CENTRALE	-	H-74	2	
215310	PERFIL PVC U JT FIXO U PVC PROFILE   PROFILÉ PVC U	L1-65 L2-49 L3-49 65	H-32	2 2+2 2 4	

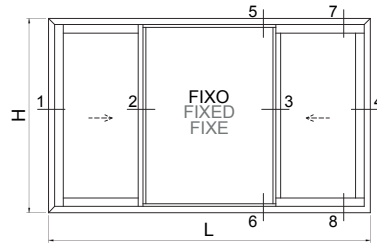

ACESSÓRIOS   ACCESSORIES   ACCESSOIRES			
CÓDIGO CODE   CODE	DESIGNAÇÃO DESIGNATION   NOMINATION		QUANT. QUANTITY QUANTITE
205129	CARRINHO JT 180KG ROLLER   ROULETTE		4
213303	CORTA-VENTO JT FIXO CENTRAL WATERPROOFING BRUSH   BROSSSE CENTRALE D'ETANCHÉITÉ		4
212337	CONJ. ESTANQ. CORTA-VENTO JT CENTRAL WATERPROOFING BRUSH KIT   KIT BROSSSE CENTRALE D'ETANCHÉITÉ		2
204153	ESQUADRO JT 11x20,5 CORNER CLEAT   EQUERRE		8
213246	CANTO CR S/SB CORNER   ANGLE		4
212199	CONJ. TOPOS LAT. JT LATERAL END-CAPS KIT   KIT D'EMBOUITS LATÉRAUX		2
212230	CONJ. TOPOS INTERIOR LAT. JT LATERAL INNER END-CAPS KIT   KIT D'EMBOUITS INTÉRIEUR LATÉRAUX		2
212201	CONJ. TAMPAS TOPOS LAT. JT LATERAL END-CAP COVERS KIT   KIT DE COUVERTURE POUR EMBOUITS LATÉRAUX		2
210239	TOPO JT64/JT65 28MM 28MM JT64/JT65 END-CAP   EMBOUT JT64/JT65 28MM		4
212231	CONJ. TOPOS CENTRAIS JT CENTRAL END-CAPS KIT   KIT D'EMBOUITS CENTRAUX		2
212339	CONJ. TAMPAS TOPOS CENTRAIS JT CENTRAL END-CAP COVERS KIT   KIT DE COUVERTURE POUR EMBOUITS CENTRAUX		2
210243	TOPO CENTRAL REFORÇADO JT54 28MM 28MM CENTRAL REINFORCED END-CAPS KIT   KIT D'EMBOUITS CENTRAUX RENFORCÉ 28MM		4
210268	GOTEIRA C/ VALV. SVE OUTSIDE FLAP VALVE   CLAPE À VOLET EXTÉRIEUR		(a)
210265	GOTEIRA C/ VALV. BOLA PRT BALL VALVE   CLAPE À BILLE		(a)
211237	FERRAGEM MULTIPONTO ALU MAE-1000 MULTIPOINT HARDWARE   SERRURE MULTIPONT		2
202330	CONTRA-FECHO ALU STRIKING PLATE   GÂCHE		4
212455	CONJ. FIX. CONTRA-FECHO AL MULTIP. JT MULTIPOINT HARDWARE STRIKING PLATE FIXING KIT   KIT FIXATION GÂCHE SERRURE MULTIPONT		4
212289	CONJ. CENTRADOR P/ FERRAGEM ALU CENTRING KIT FOR ALU HARDWARE   KIT CENTRAGE POUR SERRURE ALU		2
212371	CONJ. FIXAÇÃO JT FIXING KIT   KIT FIXATION		12
201382	FECHO DE EMBUTIR R20511X HANDLE   POIGNÉE		2
204717	GANCHO LIGAÇÃO. MULTIPONTO GMA HOOK   DROUJURE		2
212384	CONJ. TOPOS LAT. PINGADEIRA JT82 LATERAL DRIP END-CAPS KIT   KIT D'EMBOUITS LATÉRAUX POUR REJET D'EAU		1
228107	LIMITADOR ABERT. PQ SERIE CORRER OPENING LIMITER   LIMITEUR D'OUVERTURE		2
290262	PARAFUSO PK INOX PH 1 1/2X10 CQ SCREW   VIS		16
218137	CALÇO REFORÇO HORIZONTAL JT * HORIZONTAL REINFORCEMENT SHIM   CALE DE RENFORCEMENT HORIZONTALE		4
212087	CONJ. FIXAÇÃO JT 94 JT 94 FIXING KIT   KIT POUR FIXATION DU PROFILÉ JT 94		2 ou 2   ou
290030	PARAFUSO DIN7981 4.2x38 INOX A2 SCREW   VIS		8

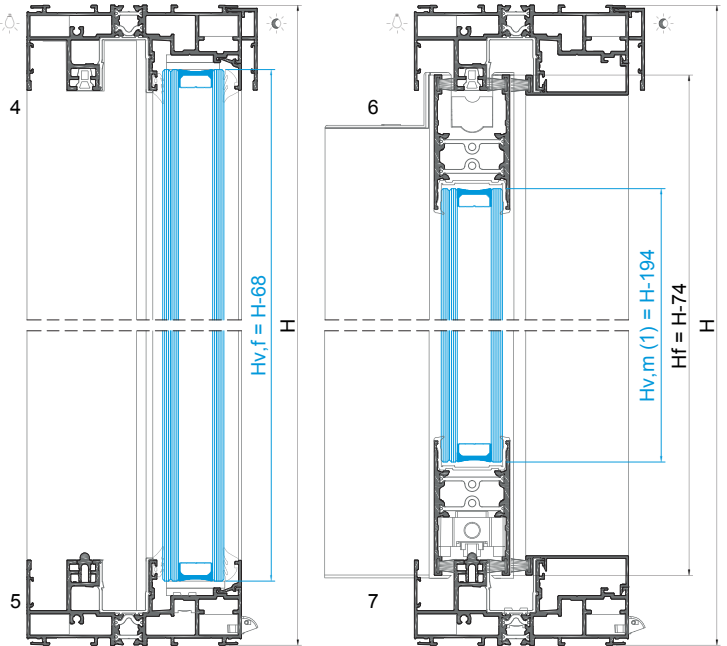

VEDANTES   SEALS   JOINTS		
CÓDIGO CODE   CODE	DESIGNAÇÃO DESIGNATION   NOMINATION	QUANT. QUANTITY QUANTITE
208348	JUNTA TAPA CANAL 2116 JT JOINT   JOINT	1L + 2H
208099	JUNTA VIDRO U 1032 CX 32MM JT GLAZING GASKET   JOINT DE VITRAGE	1L + 4H
208307	PELUCIA 7x10 TRI-FIN PRETA PILE SEAL   JOINT BROSSSE	3L + 10H
208350	JUNTA EXTERIOR 2003 JOINT   JOINT	(2xL2) + 2H
	JUNTA INTERIOR CUNHA JOINT   JOINT	(2xL2) + 2H

\* Usar em folhas com vidros com peso superior a 80kg  
To be used in sashes with glass weight exceed 80kg | Utiliser dans des panneaux de verre d'un poids supérieur à 80 kg  
(a) Conforme esquemas de drenagem (Capítulo V - Maquinações)  
According to drainage schemes (Chapter V - Machinings) | Selon les schémas de drainage (Chapitre V - Usinages)

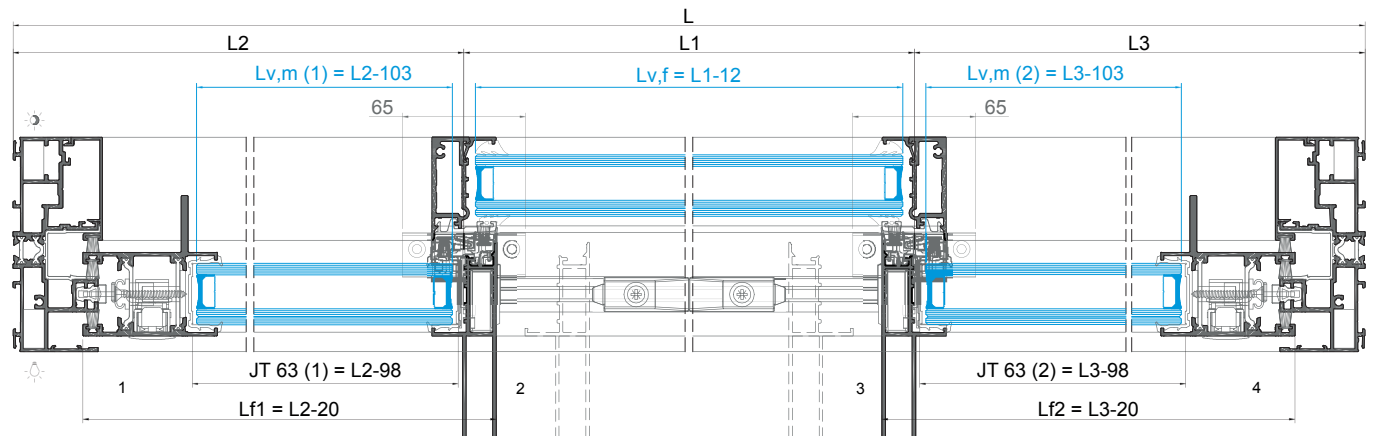

JANELA DE CORRER COM MOSQUITEIRA INTERIOR - 2RAIL  
SLIDING WINDOW WITH INNER MOSQUITO NET - 2RAIL  
FENÊTRE COULISSANT AVEC MOSQUITAIRE INTÉRIEUR - 2RAIL

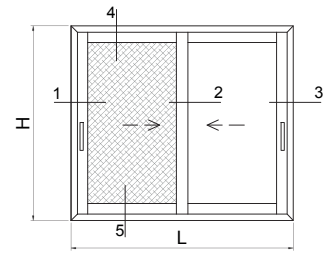

Com LINHA FR  
With FR LINE  
Avec LIGNE FR

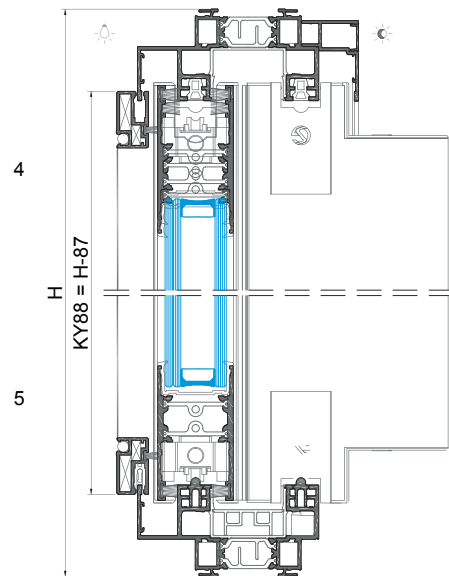
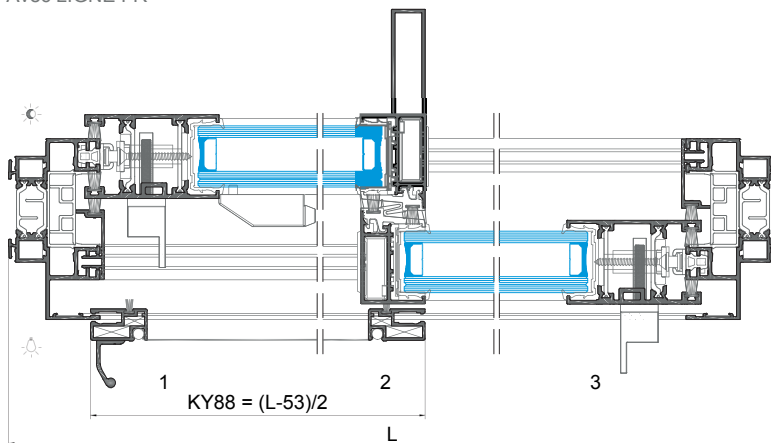

Com LINHA PT  
With PT LINE  
Avec LIGNE PT

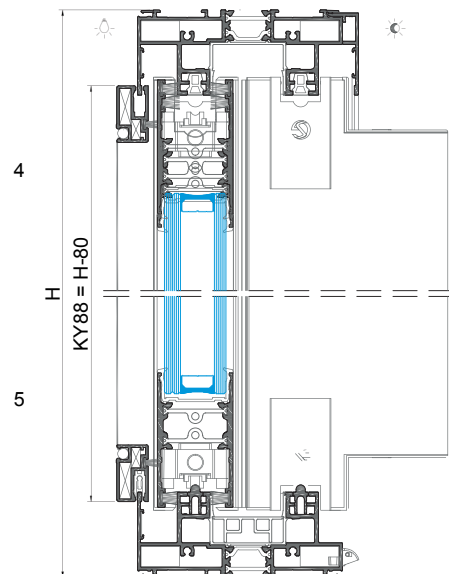
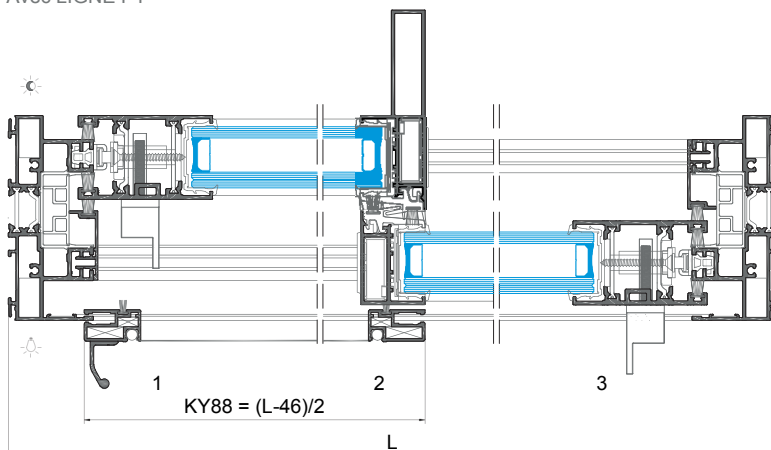



JANELA DE CORRER COM MOSQUITEIRA EXTERIOR - 3RAIL  
SLIDING WINDOW WITH OUTER MOSQUITO NET - 3RAIL  
FENÊTRE COULISSANT AVEC MOSQUITAIRE EXTÉRIEUR - 3RAIL

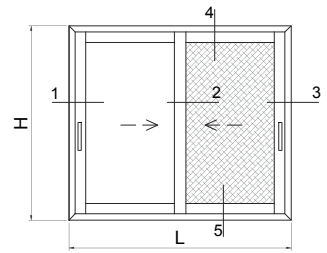

Com LINHA FR  
With FR LINE  
Avec LIGNE FR

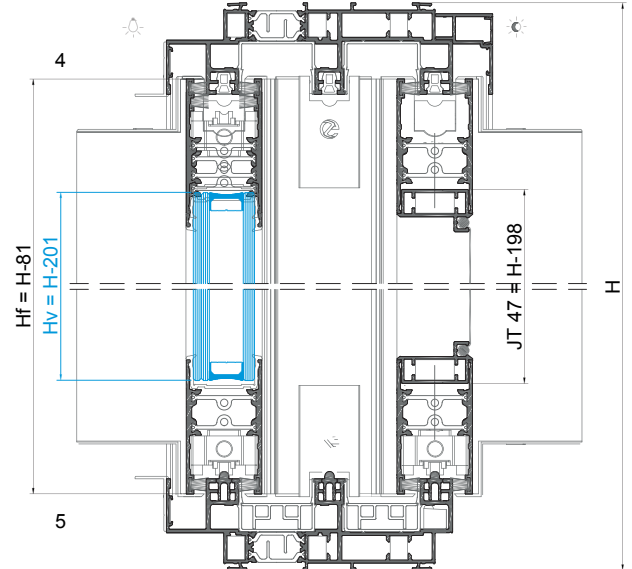
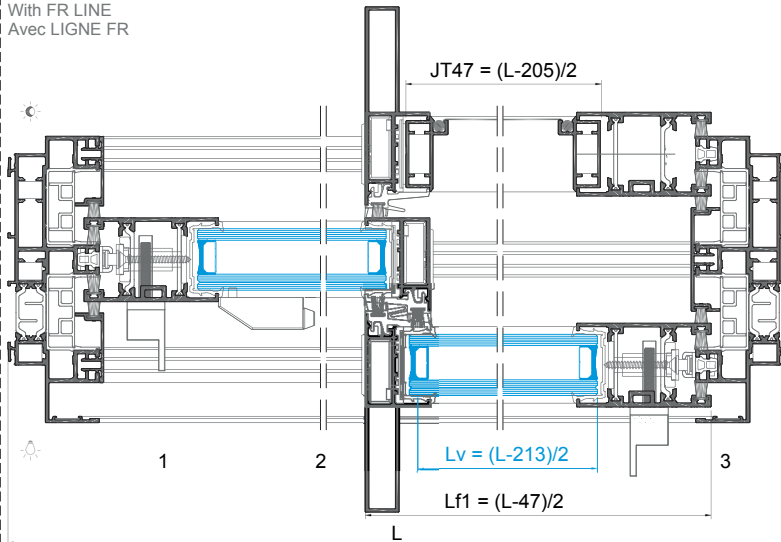

Com LINHA PT  
With PT LINE  
Avec LIGNE PT

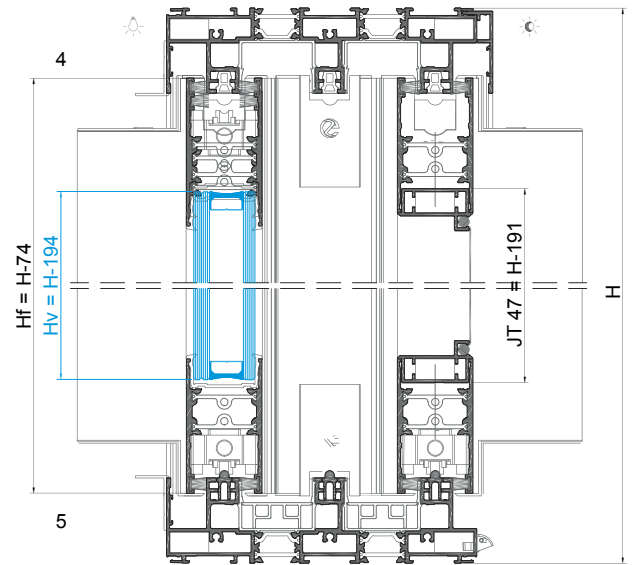
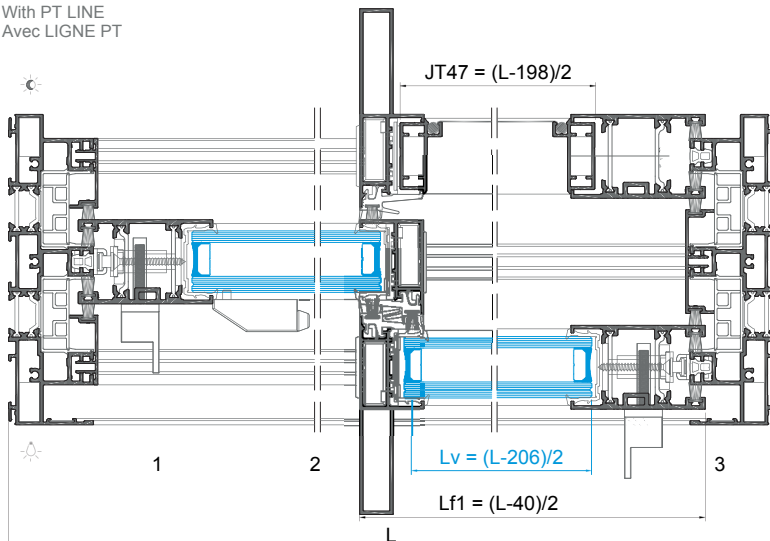

Com LINHA SOLEIRA 30MM  
With 30MM SILL LINE  
Avec LIGNE SEUIL 30MM

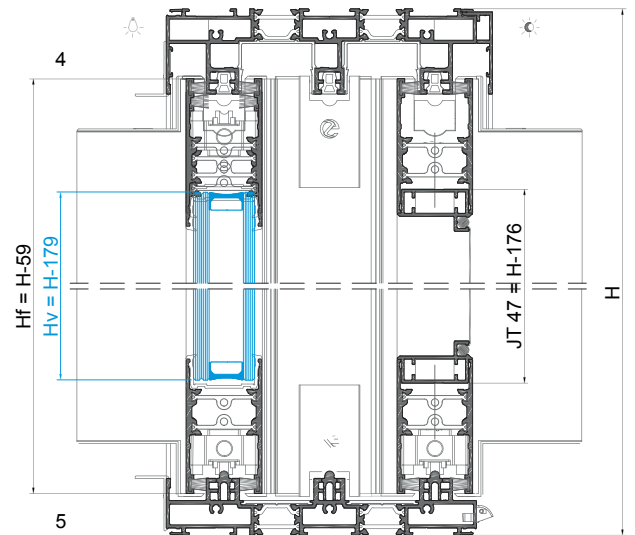
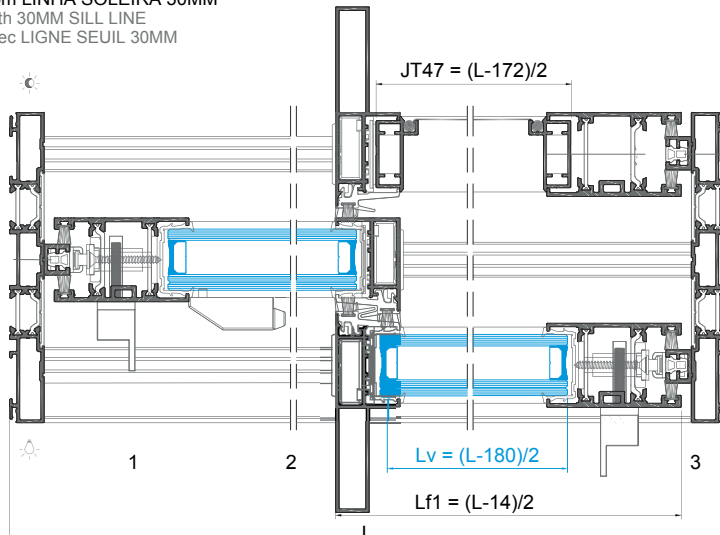

JANELA DE CORRER COM PORTADA EXTERIOR - 3RAIL  
SLIDING WINDOW WITH OUTER SHUTTER - 3RAIL  
FENÊTRE COULISSANT AVEC VOLET EXTÉRIEUR - 3RAIL

Com LINHA FR  
With FR LINE  
Avec LIGNE FR

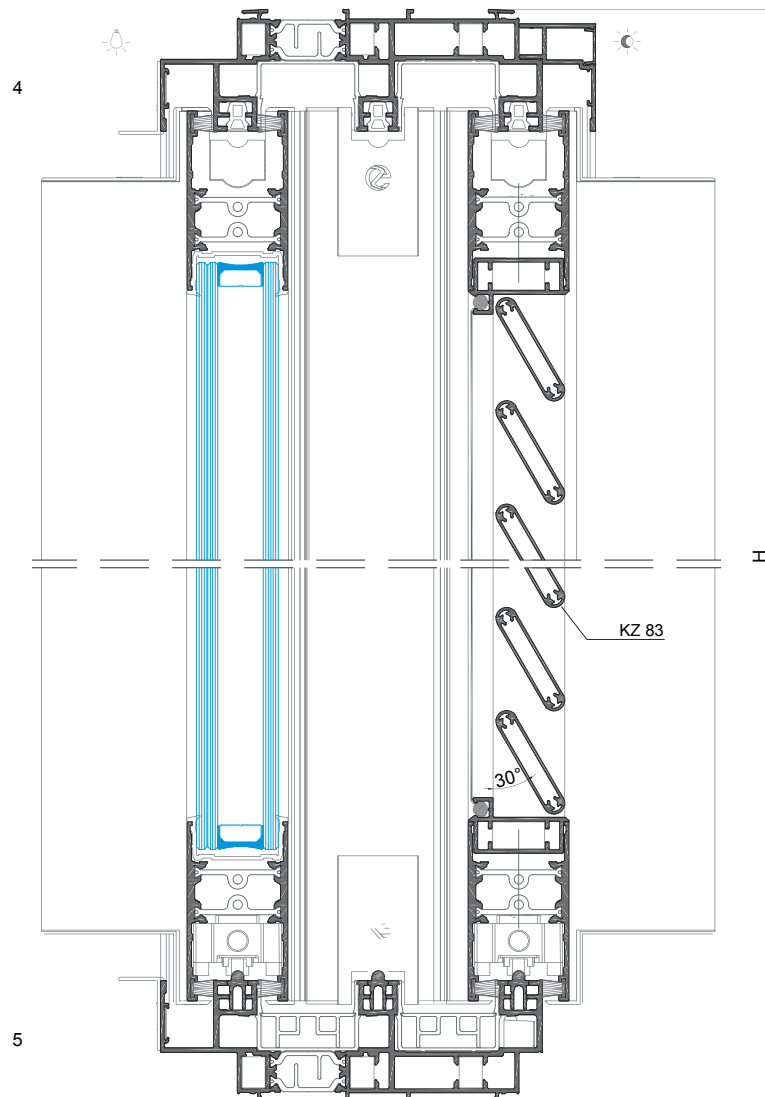
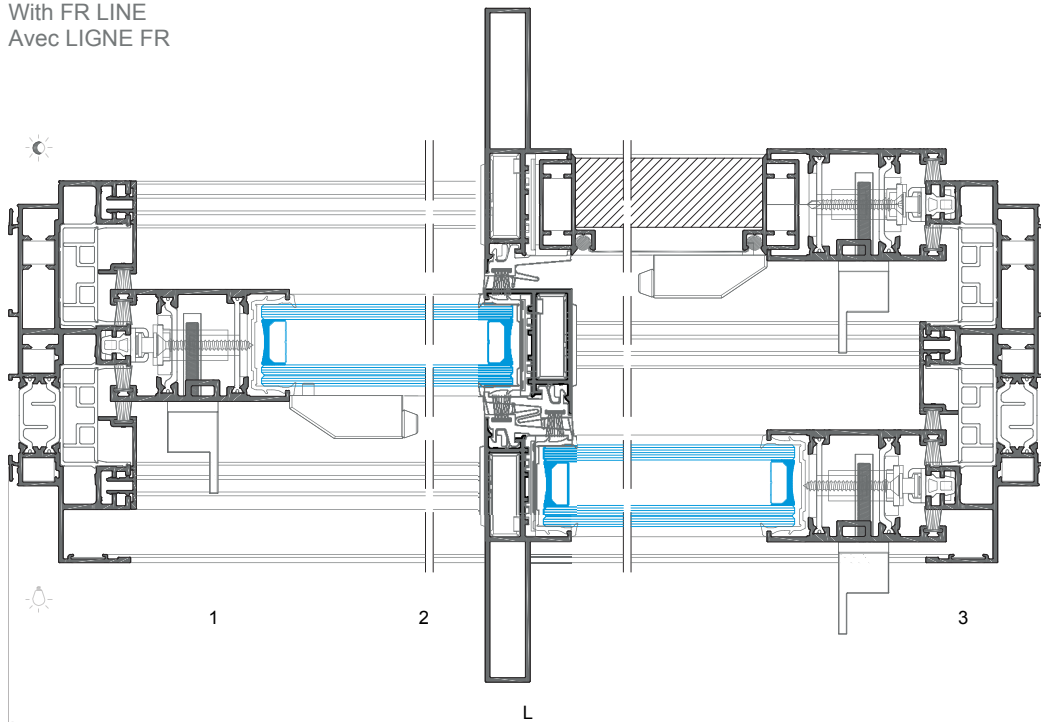

APLICAÇÃO DAS PEÇAS DE FIXAÇÃO **RENOVATIO**  
**RENOVATIO** FIXING PARTS APPLICATION  
 APPLICATION DES PIÈCES DE FIXATION **RENOVATIO**

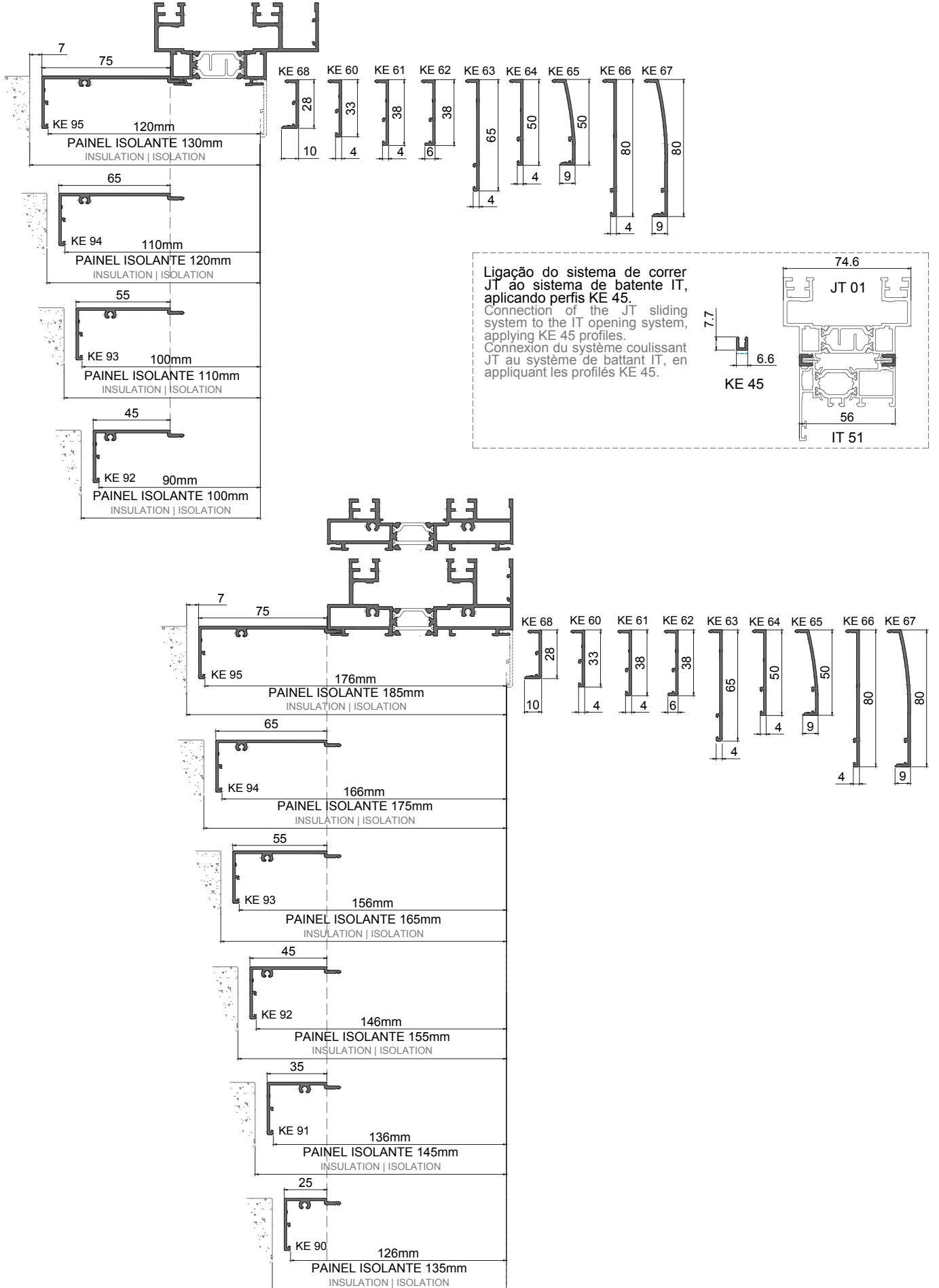

**APLICAÇÃO DAS PEÇAS DE FIXAÇÃO RENOVATIO**  
 RENOVIATIO FIXING PARTS APPLICATION  
 APPLICATION DES PIÈCES DE FIXATION RENOVIATIO

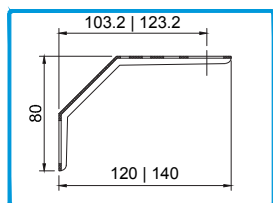

213240 ÂNGULO DE FIXAÇÃO 120MM  
 213256 ÂNGULO DE FIXAÇÃO 140MM

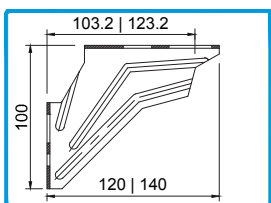

230019 SUPORTE DE FIXAÇÃO 120MM  
 230308 SUPORTE DE FIXAÇÃO 140MM

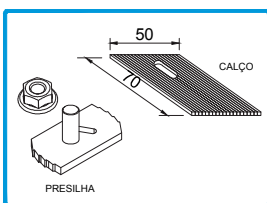

207220 PRESILHA M6x37MM  
 218116 CALÇO SEPARADOR 50x70MM

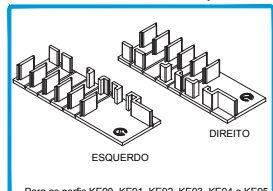

212223 CONJ. TOPOS INFERIORES RENOVIATIO

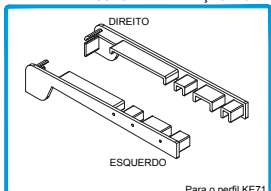

212221 CONJUNTO TAPA TOPOS KE 71

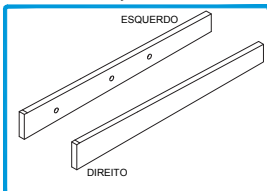

212227 CONJ. JUNTAS ADESIVAS P/ TOPOS PERFIL SOLEIRA KE71

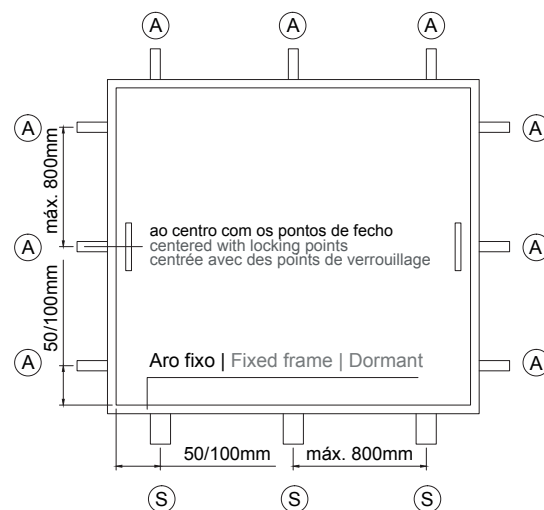

**A) PAINEL ISOLANTE DE 120MM | 120MM INSULATION PANEL | PANNEAU ISOLANT 120MM**

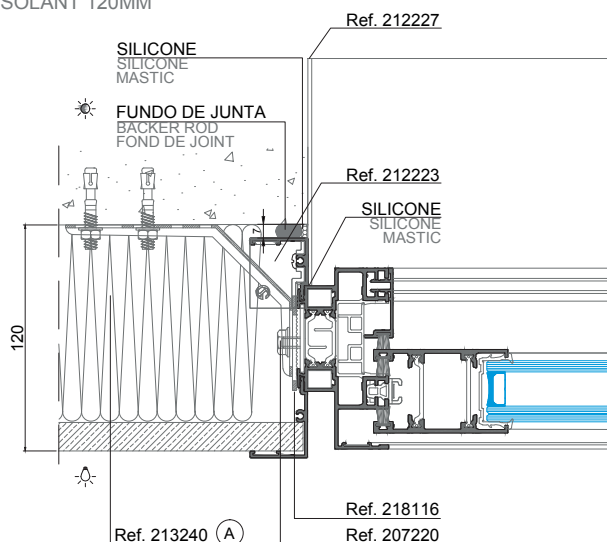
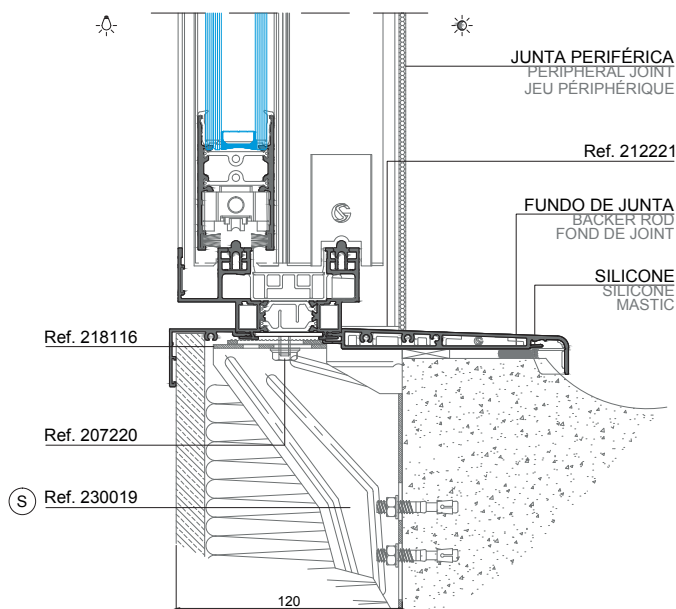

**B) PAINEL ISOLANTE DE 170MM | 170MM INSULATION PANEL | PANNEAU ISOLANT 170MM**

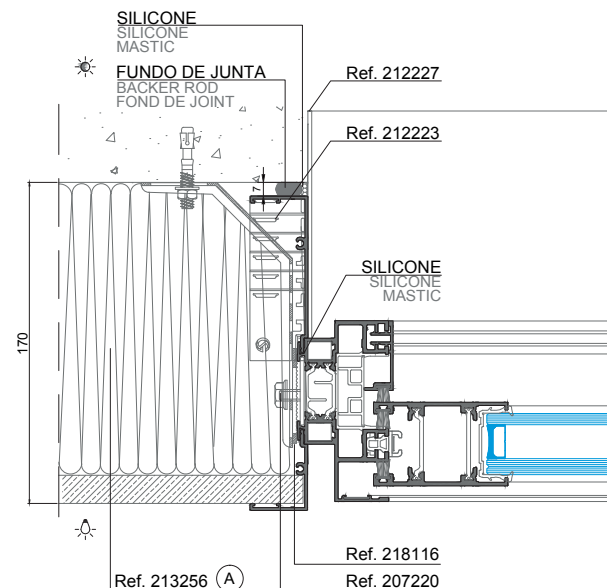
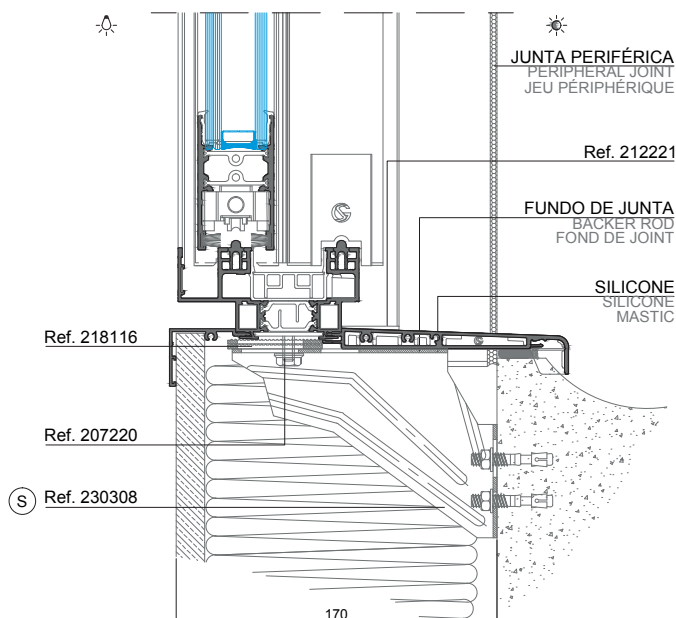

JANELA / PORTA DE CORRER 2 FOLHAS - PERFIS FR 2RAIL  
2 SASHES SLIDING WINDOW / DOOR - 2RAIL FR PROFILES  
FENÊTRE / PORTE-FENÊTRE COULISSANT 2 VANTAUX - PROFILÉS FR 2RAIL

PERFIS   PROFILES   PROFILÉS					
CÓDIGO CODE   CODE	DESIGNAÇÃO DESIGNATION   NOMINATION	CORTE HORIZ. HORIZONTAL CUT COUPE HORIZ.	CORTE VERT. VERTICAL CUT COUPE VERTICALE	QUANT. QUANTITY QUANTITÉ	CORTE CUT COUPE
JT 02	ARO FIXO FIXED FRAME   CADRE DORMANT	L	H	2 + 2	
JT 56	PERFIL CENTRAL CENTRAL PROFILE   PROFILÉ CENTRAL	-	H-81	2	
JT 60	PERFIL LATERAL LATERAL PROFILE   PROFILÉ LATÉRAL	-	H-81	2	
JT 69	TRAVESSA SUP/INF UP/LW TRANSOM   TRAVERSE SUP/INF	(L-159)/2	-	4	
AT 30	CAPA COVER   CAPOT	L-44	-	1	
JT 83	PERFIL PINGADEIRA DRIP PROFILE   LARMIER	L-44	-	1	
JT 85	CAPA COVER   CAPOT	-	H-58	2	
JT 87	GUIA GUIDE   GUIDE	L-100	-	2	
208351	JUNTA CENTRAL 2197 CENTRAL JOINT   JOINT CENTRALE	-	H-81	2	
215305	PERFIL PVC U U PVC PROFILE   PROFILÉ PVC U	L-41	H-41	2 + 2	
215303	PERFIL PVC T T PVC PROFILE   PROFILÉ PVC T	(L-122)/2	H-44	2 + 2	

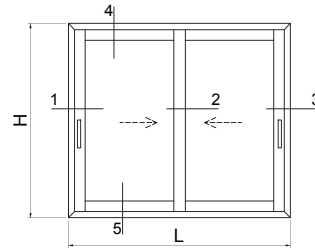

ACESSÓRIOS   ACCESSORIES   ACCESSOIRES		
CÓDIGO CODE   CODE	DESIGNAÇÃO DESIGNATION   NOMINATION	QUANT. QUANTITY QUANTITÉ
205000	CARRINHO JT-SLIM ROLLER   ROULETTE	4
213402	CORTA-VENTO JT-SLIM CENTRAL WATERPROOFING PILE SEAL   BROSSSE CENTRALE D'ÉTANCHÉITÉ	2
212337	CONJ. ESTANQ. CORTA-VENTO JT CENTRAL WATERPROOFING PILE SEAL KIT   KIT BROSSSE CENTRALE D'ÉTANCHÉITÉ	1
204164	ESQUADRO JT 12x9.5 CORNER CLEAT   ÉQUERRE	8
213014	CANTO ALINHAMENTO JT ALIGNMENT CORNER   ANGLE D'ALIGNEMENT	4
213246	CANTO CR S/SB CORNER   ANGLE	4
212131	CONJ. TOPOS LATERAL JT-SLIM LATERAL END-CAPS KIT   KIT D'EMBOUTS LATÉRAUX	2
212133	CONJ. TOPOS CENTRAL JT-SLIM CENTRAL END-CAPS KIT   KIT D'EMBOUTS CENTRAUX	2
210231	TOPO CENTRAL REFORÇADO JT56 28MM 28MM CENTRAL REINFORCED END-CAPS KIT   KIT D'EMBOUTS CENTRAUX RENFORCÉ 28MM	4
210269	GOITEIRA OCULTA C/ VALV. SV-C13 GLASS VALVE   CLAPÉ À VALVET GÂCHE	(a)
211234	MULTIPONTO ALU MAC.1000 (2P) MULTIPOINT HARDWARE   SERRURE MULTIPONT	2
202330	CONTRA-FECHO ALU STRIKING PLATE   GÂCHE	4
212455	CONJ. FIX. CONTRA-FECHO AL MULTIP. JT MULTIPOINT HARDWARE STRIKING PLATE FIXING KIT   KIT FIXATION GÂCHE SERRURE MULTIPONT	4
212289	CONJ. CENTRADOR P/ FERRAGEM ALU CENTERING KIT FOR ALU HARDWARE   KIT CENTRAGE POUR SERRURE ALU	2
212373	CONJ. FIXAÇÃO JT-SLIM FIXING KIT   KIT FIXATION	12
200819	PUXADOR SLIM XS - ESQUERDO LEFT HANDLE   POIGNEE GAUCHE	1
200817	PUXADOR SLIM XS - DIREITO RIGHT HANDLE   POIGNEE DROITE	1
212341	CONJ. TOPOS LAT. PINGADEIRA LATERAL DRIP END-CAPS KIT   KIT D'EMBOUTS LATÉRAUX POUR REJET D'EAU	1
228107	LIMITADOR ABERT. PQ SERIE CORRER OPENING LIMITER   LIMITEUR D'OUVERTURE	1
290472	PARAF. AT/PF CQ Ø3.9x19MM SCREW   VIS	1 + 1 un./m
290087	PARAF. DIN7981 PH 4,8x63 INOX A2 SCREW   VIS	4
290091	PARAFUSO DIN7981 PH 4,8x50 A2 SCREW   VIS	4
290465	PARAF. M5x30 (PARA PUXADOR SLIM XS) SCREW   VIS	4
290051	PARAFUSO AUTO-PERF. CX 4,2x13 A2 (PARA PUXADOR SLIM XS) SCREW   VIS	4
218147	CALÇO REFORÇO HORIZONTAL JT-SLIM * HORIZONTAL REINFORCEMENT SHIM   CALE DE RENFORCEMENT HORIZONTALE	4

\* Usar em folhas com vidros com peso superior a 80kg  
To be used in sashes which glass weight exceed 80kg | Utiliser dans des panneaux de verre d'un poids supérieur à 80 kg  
(a) Conforme esquemas de drenagem (Capítulo V - Maquinações)  
According to drainage schemes (Chapter V - Machinings) | Selon les schémas de drainage (Chapitre V - Usinages)

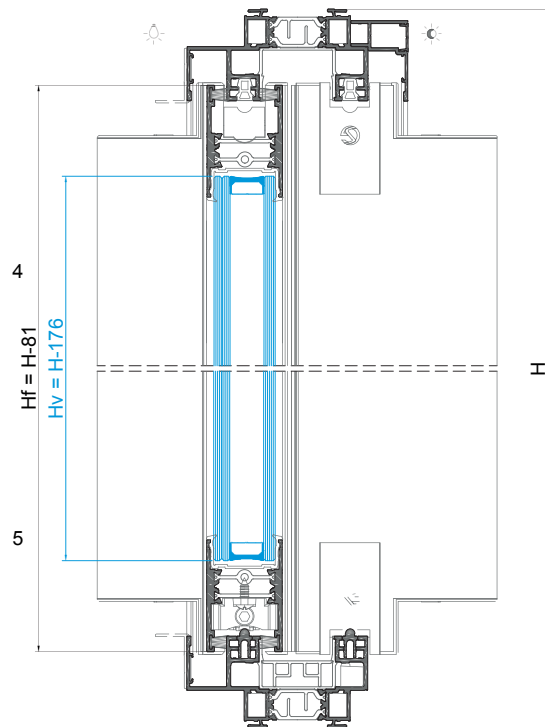

VEDANTES   SEALS   JOINTS		
CÓDIGO CODE   CODE	DESIGNAÇÃO DESIGNATION   NOMINATION	QUANT. QUANTITY QUANTITÉ
208348	JUNTA TAPA CANAL 2116 JT JOINT   JOINT	2L + 2H
208099	JUNTA VIDRO U 1032 CX 32MM JT GLAZING GASKET   JOINT DE VITRAGE	2L + 4H
208307	PELÚCIA 7x10 TRI-FIN PRETA PILE SEAL   JOINT BROSSSE	4L + 6H
208469	PELÚCIA SRF 4X8 2P1M Preta PILE SEAL   JOINT BROSSSE	2H

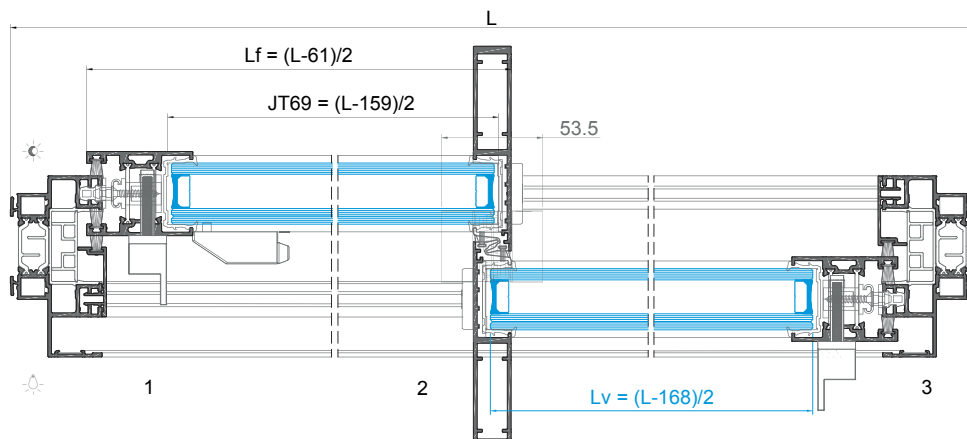

**JANELA DE CORRER 4 FOLHAS 2-RAIL COM LIGAÇÃO CENTRAL - LINHA FR**  
4 SASHES SLIDING 2-RAIL WINDOW WITH CENTRAL CONNECTION - FR LINE  
FENÊTRE COULISSANT 4 VANTAU 2-RAIL AVEC CONNEXION CENTRALE - LIGNE FR

PERFIS   PROFILES   PROFILÉS					
CÓDIGO CODE   CODE	DESIGNAÇÃO DESIGNATION   NOMINATION	CORTE HORIZ. HORIZONTAL CUT COUPE HORIZ.	CORTE VERT. VERTICAL CUT COUPE VERTICALE	QUANT. QUANTITY QUANTITE	CORTE CUT COUPE
JT 02	ARO FIXO FIXED FRAME   CADRE DORMANT	L	H	2 + 2	
JT 56	PERFIL CENTRAL CENTRAL PROFILE   PROFILÉ CENTRAL	-	H-81	4	
JT 60	PERFIL LATERAL LATERAL PROFILE   PROFILÉ LATÉRAL	-	H-81	4	
JT 69	TRAVESSA SUP/INF UP/LW TRANSOM   TRAVERSE SUP/INF	(L-245)/4	-	8	
JT 71	PERFIL LIGAÇÃO CENTRAL CONNECTION PROFILE   PROFILÉ DE LIAISON	-	H-140	1	
AT 30	CAPA COVER   CAPOT	L-44	-	1	
JT 83	PERFIL PINGADEIRA DRIP PROFILE   LARMIER	L-44	-	1	
JT 85	CAPA COVER   CAPOT	-	H-58	2	
JT 87	GUIA GUIDE   GUIDE	L-102 L-97	-	1 1	
208351	JUNTA CENTRAL 2197 CENTRAL JOINT   JOINT CENTRALE	-	H-81	4	
215305	PERFIL PVC U U PVC PROFILE   PROFILÉ PVC U	L-41	H-41	2 + 2	
215303	PERFIL PVC T T PVC PROFILE   PROFILÉ PVC T	(L-174)/4 (L-289)/4	H-44	2 + 2	

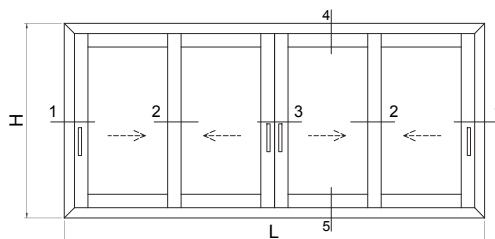

ACESSÓRIOS   ACCESSORIES   ACCESSOIRES			
CÓDIGO CODE   CODE	DESIGNAÇÃO DESIGNATION   NOMINATION	QUANT. QUANTITY QUANTITE	
205000	CARRINHO JT-SLIM ROLLER   ROULETTE	8	
213402	CORTA-VENTO JT-SLIM CENTRAL WATERPROOFING BRUSH   BROSSE CENTRALE D'ÉTANCHÉITÉ	6	
212337	CONJ. ESTANQ. CORTA-VENTO JT CENTRAL WATERPROOFING BRUSH KIT   KIT BROSSE CENTRALE D'ÉTANCHÉITÉ	3	
204164	ESQUADRO JT 12x9.5 CORNER CLEAT   ÉQUERRE	8	
213014	CANTO ALINHAMENTO JT ALIGNMENT CORNER   ANGLE D'ALIGNEMENT	4	
213246	CANTO CR S/SB CORNER   ANGLE	4	
212131	CONJ. TOPOS LATERAL JT-SLIM LATERAL END-CAPS KIT   KIT D'EMBOUTS LATÉRAUX	4	
212133	CONJ. TOPOS CENTRAL JT-SLIM CENTRAL END-CAPS KIT   KIT D'EMBOUTS CENTRAUX	4	
210231	TOPO CENTRAL REFORÇADO JTS66 28MM 28MM CENTRAL REINFORCED END-CAPS KIT   KIT D'EMBOUTS CENTRAUX RENFORCÉ 28MM	8	
212135	CONJ. TOPOS LIG. 2 FOLHAS JT-SLIM 2 SASHES CONNECTING END-CAPS KIT   KIT D'EMBOUTS CONNEXION 2 VANTAU	1	
210269	GOTEIRA OCULTA C/ VALV. SV-C13 FLAP VALVE   CLAPE À VOILE CACHÉ	(a)	
211234	MULTIPONTO ALU MAC. 1000 (2P) MULTIPOINT HARDWARE   SERRURE MULTIPOINT	3	
202330	CONTRA-FECHO ALU STRIKING PLATE   GÂCHE	4	
212455	CONJ. FIX. CONTRA-FECHO AL MULTIP. JT MULTIPOINT HARDWARE STRIKING PLATE FIXING KIT   KIT FIXATION GÂCHE SERRURE MULTIPOINT	4	
202331	CONTRA-FECHO Nº2 2F/90º ALU STRIKING PLATE   GÂCHE	2	
212458	CONJ. FIX. CONTRA-FECHO MULTIP. 2F/90º JT MULTIPOINT HARDWARE STRIKING PLATE FIXING KIT   KIT FIXATION GÂCHE SERRURE MULTIP.	2	
212289	CONJ. CENTRADOR P/ FERRAGEM ALU CENTERING KIT FOR ALU HARDWARE   KIT CENTRAGE POUR SERRURE ALU	2	
212291	CONJ. CENTRADOR P/ FERRAGEM ALU PERFIL LIG. CENTERING KIT FOR ALU HARDWARE   KIT CENTRAGE POUR SERRURE ALU	1	
212373	CONJ. FIXAÇÃO JT-SLIM FIXING KIT   KIT FIXATION	18	
212017	CONJ. FIX. FERRAGEM MULTIP. MULTIPOINT HARDWARE FIXING KIT   KIT FIXATION POUR SERRURE MULTIPOINT	1 + 1 un./m (min. 4)	
200819	PUXADOR SLIM XS - ESQUERDO LEFT HANDLE   POIGNÉE GAUCHE	1	
200817	PUXADOR SLIM XS - DIREITO RIGHT HANDLE   POIGNÉE DROITE	2	
200057	PUXADOR FOLHA PASSIVA SLIM XS PASSIVE SASH HANDLE   POIGNÉE VENTAIL PASSIVE	1	
212341	CONJ. TOPOS LAT. PINGADEIRA LATERAL DRIP END-CAPS KIT   KIT D'EMBOUTS LATÉRAUX POUR REJET D'EAU	1	
228107	LIMITADOR ABERT. PQ SERIE CORRER OPENING LIMITER   LIMITÉUR D'OUVERTURE	2	
290472	PARAF. AT/PF CQ Ø3.9x19MM SCREW   VIS	1 + 1 un./m	
290087	PARAF. DIN7981 PH 4,8x63 INOX A2 SCREW   VIS	8	
290091	PARAFUSO DIN7981 PH 4,8x50 A2 SCREW   VIS	8	
290465	PARAF. M5x30 (PARA PUXADOR SLIM XS) SCREW   VIS	6	
290051	PARAFUSO AUTO-PERF. CX 4,2X13 A2 (PARA PUXADOR SLIM XS) SCREW   VIS	6	
218147	CALÇO REFORÇO HORIZONTAL JT-SLIM * HORIZONTAL REINFORCEMENT SHIM   CALE DE RENFORCEMENT HORIZONTALE	8	

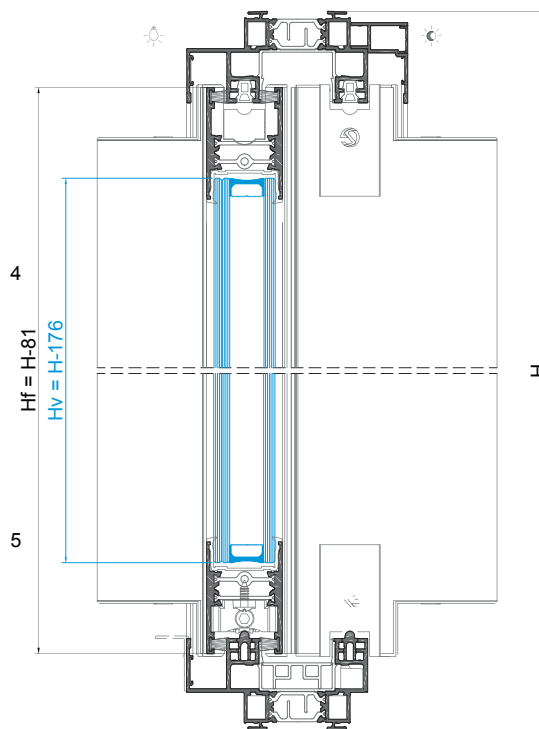

VEDANTES   SEALS   JOINTS		
CÓDIGO CODE   CODE	DESIGNAÇÃO DESIGNATION   NOMINATION	QUANT. QUANTITY QUANTITE
208348	JUNTA TAPA CANAL 2116 JT JOINT   JOINT	2L + 2H
208099	JUNTA VIDRO U 1032 CX 32MM JT GLAZING GASKET   JOINT DE IVTRAGE	2L + 8H
208307	PELÚCIA 7x10 TRI-FIN PRETA PILE SEAL   JOINT BROSSE	4L + 10H
208479	JUNTA TAPA CANAL PERFIL LIG. 2117 JT JOINT   JOINT	H
208469	PELÚCIA SRF 4X8 2P1M Preta PILE SEAL   JOINT BROSSE	4H

\* Usar em folhas com vidros com peso superior a 80kg  
To be used in sashes which glass weight exceed 80kg | Utiliser dans des panneaux de verre d'un poids supérieur à 80 kg  
(a) Conforme esquemas de drenagem (Capítulo V - Maquinações)  
According to drainage schemes (Chapter V - Machinings) | Selon les schémas de drainage (Chapitre V - Usinages)

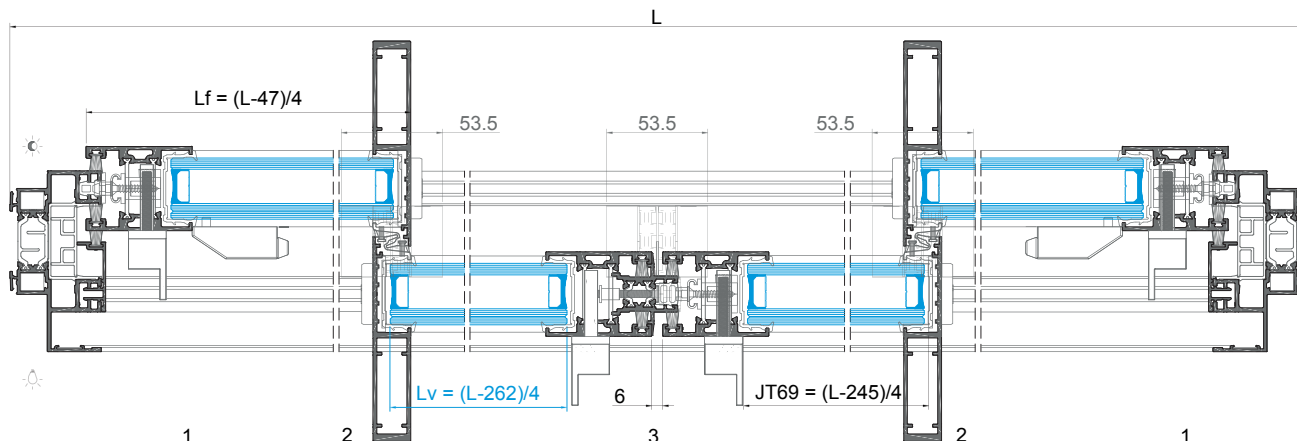



JANELA DE CORRER 4 FOLHAS 2-RAIL CANTO 90° - LINHA FR  
4 SASHES 2-RAIL SLIDING WINDOW IN 90° CORNER - FR LINE  
FENÊTRE COULISSANT 4 VANTAUX 2-RAIL À ANGLE 90° - LIGNE FR

PERFIS   PROFILES   PROFILÉS					
CÓDIGO CODE   CODE	DESIGNAÇÃO DESIGNATION   NOMINATION	CORTE HORIZ. HORIZONTAL CUT COUPE HORIZ.	CORTE VERT. VERTICAL CUT COUPE VERTICALE	QUANT. QUANTITY QUANTITE	CORTE CUT COUPE
JT 02	ARO FIXO FIXED FRAME   CADRE DORMANT	L1 L2	H	2 + 2	
JT 56	PERFIL CENTRAL CENTRAL PROFILE   PROFILÉ CENTRAL	-	H-81	4	
JT 60	PERFIL LATERAL LATERAL PROFILE   PROFILÉ LATERAL	-	H-81	2	
JT 70	PERFIL LATERAL CANTO 90° 90° CORNER LAT. PR.   PR. LAT. D'ANGLE À 90°	-	H-81	2	
JT 69	TRAVESSA SUP/INF UP/LW TRANSOM   TRAVERSE SUP/INF	(L1-200)/2 (L2-213)/2	-	4 4	
JT 72	PERFIL LIGAÇÃO CANTO 90° CONNECTION PROFILE   PROFILÉ DE LIAISON	-	H-140	1	
AT 30	CAPA COVER   CAPOT	L1-1 L2-1	-	1 1	
JT 83	PERFIL PINGADEIRA DRIP PROFILE   LARMIER	L1-1 L2-1	-	1 1	
JT 85	CAPA COVER   CAPOT	-	H-58	2	
JT 87	GUIA GUIDE   GUIDE	L1-43 L1-112 L2-43 L2-112	-	1 1 1 1	
208351	JUNTA CENTRAL 2197 CENTRAL JOINT   JOINT CENTRALE	-	H-81	4	
215305	PERFIL PVC U U PVC PROFILE   PROFILÉ PVC U	L1-38 L2-38	H-41	2 + 2	
215303	PERFIL PVC T T PVC PROFILE   PROFILÉ PVC T	(L1-165)/2 (L1-228)/2 (L2-216)/2 (L2-178)/2	H-44	1 1 + 2 1	

VEDANTES   SEALS   JOINTS		
CÓDIGO CODE   CODE	DESIGNAÇÃO DESIGNATION   NOMINATION	QUANT. QUANTITY QUANTITE
208348	JUNTA TAPA CANAL 2116 JT JOINT   JOINT	2L1 2L2 + 2H
208099	JUNTA VIDRO U 1032 CX 32MM JT GLAZING GASKET   JOINT DE IVTRAGE	2L1 2L2 + 8H
208307	PELÚCIA 7x10 TRI-FIN PRETA PILE SEAL   JOINT BRUSSE	4L1 + 11H 4L2
208479	JUNTA TAPA CANAL PERFIL LIG. 2117 JT JOINT   JOINT	H
208435	JUNTA VD 2415 JOINT   JOINT	H
208469	PELÚCIA SRF 4X8 2P1M Preta PILE SEAL   JOINT BRUSSE	4H

ACESSÓRIOS   ACCESSORIES   ACCESSOIRES			
CÓDIGO CODE   CODE	DESIGNAÇÃO DESIGNATION   NOMINATION	QUANT. QUANTITY QUANTITE	
205000	CARRINHO JT-SLIM ROLLER   ROULETTE	8	
213402	CORTA-VENTO JT-SLIM CENTRAL WATERPROOFING BRUSH   BRUSSE CENTRALE D'ETANCHÉITÉ	4	
213287	CORTA-VENTO CANTO 90° JT 90° CORNER WATERPROOFING BRUSH   BRUSSE D'ETANCHÉITÉ ANGLE 90°	2	
212337	CONJ. ESTANQ. CORTA-VENTO JT CENTRAL WATERPROOFING BRUSH KIT   KIT BRUSSE CENTRALE D'ETANCHÉITÉ	4	
204164	ESQUADRO JT 12x9.5 CORNER CLEAT   EQUERRE	8	
213014	CANTO ALINHAMENTO JT ALIGNMENT CORNER   ANGLE D'ALIGNEMENT	4	
212243	CONJ. UNIÃO CANTO 90° JT 90° CORNER UNION KIT   KIT D'UNION ANGLE 90°	1	
204389	ESQUADRO INOX CANTO 90° 90° STAINLESS STEEL CORNER   ANGLE EN ACIER INOXYDABLE 90°	2	
213246	CANTO CR S/SB CORNER   ANGLE	4	
212131	CONJ. TOPOS LATERAL JT-SLIM LATERAL END-CAPS KIT   KIT D'EMBOUTS LATÉRAUX	4	
212133	CONJ. TOPOS CENTRAL JT-SLIM CENTRAL END-CAPS KIT   KIT D'EMBOUTS CENTRAUX	4	
210231	TOPO CENTRAL REFORÇADO JT56 28MM 28MM CENTRAL REINFORCED END-CAPS KIT   KIT D'EMBOUTS CENTRAUX RENFORCÉ 28MM	8	
212151	CONJ. TOPOS CANTO 90° JT-SLIM 90° CORNER END-CAPS KIT   KIT D'EMBOUTS POUR ANGLE 90°	1	
210269	GOTEIRA OCULTA C/ VALV. SV-C13 FLAP VALVE   CLAPE À VOLET CACHE	(a)	
211234	MULTIPONTO ALU MAC.1000 (2P) MULTIPOINT HARDWARE   SERRURE MULTIPONT	3	
202330	CONTRA-FECHO ALU STRIKING PLATE   GÂCHE	4	
212455	CONJ. FIX. CONTRA-FECHO AL MULTIP. JT MULTIPOINT HARDWARE STRIKING PLATE FIXING KIT   KIT FIXATION GÂCHE SERRURE MULTIPONT	4	
202331	CONTRA-FECHO Nº2 2F/90° ALU STRIKING PLATE   GÂCHE	2	
212458	CONJ. FIX. CONTRA-FECHO MULTIP. 2F/90° JT MULTIPOINT HARDWARE STRIKING PLATE FIXING KIT   KIT FIXATION GÂCHE SERRURE MULTIP.	2	
212289	CONJ. CENTRADOR P/ FERRAGEM ALU CENTERING KIT FOR ALU HARDWARE   KIT CENTRAGE POUR SERRURE ALU	2	
212291	CONJ. CENTRADOR P/ FERRAGEM ALU PERFIL LIG. CENTERING KIT FOR ALU HARDWARE   KIT CENTRAGE POUR SERRURE ALU	1	
212373	CONJ. FIXAÇÃO JT-SLIM FIXING KIT   KIT FIXATION	18	
212079	CONJ. FIX. FERRAGEM MULTIP. JT72 MULTIPOINT FIXING KIT   KIT FIXATION SERRURE MULTIPONT	1 + 1 un./m (min. 4)	
200819	PUXADOR SLIM XS - ESQUERDO LEFT HANDLE   POIGNÉE GAUCHE	1	
200817	PUXADOR SLIM XS - DIREITO RIGHT HANDLE   POIGNÉE DROITE	2	
212341	CONJ. TOPOS LAT. PINGADEIRA LATERAL DRIP END-CAPS KIT   KIT D'EMBOUTS LATÉRAUX POUR REJET D'EAU	1	
228107	LIMITADOR ABERT. PQ SERIE CORRER OPENING LIMITER   LIMITEUR D'OUVERTURE	2	
290472	PARAF. AT/PF CQ Ø3.9x19MM SCREW   IVS	1 + 1 un./m	
290087	PARAF. DIN7981 PH 4,8x63 INOX A2 SCREW   IVS	8	
290091	PARAFUSO DIN7981 PH 4,8x50 A2 SCREW   IVS	8	
290465	PARAF. M5x30 (PARA PUXADOR SLIM XS) SCREW   IVS	6	
290051	PARAFUSO AUTO-PERF. CX 4,2x13 A2 (PARA PUXADOR SLIM XS) SCREW   IVS	6	
218147	CALÇO REFORÇO HORIZONTAL JT-SLIM * HORIZONTAL REINFORCEMENT SLIM   CALE DE RENFORCEMENT HORIZONTALE	8	

\* Usar em folhas com vidros com peso superior a 80kg  
To be used in sashes which glass weight exceed 80kg | Utiliser dans des panneaux de verre d'un poids supérieur à 80 kg  
(a) Conforme esquemas de drenagem (Capítulo V - Maquinações)  
According to drainage schemes (Chapter V - Machinings) | Selon les schémas de drainage (Chapitre V - Usinages)

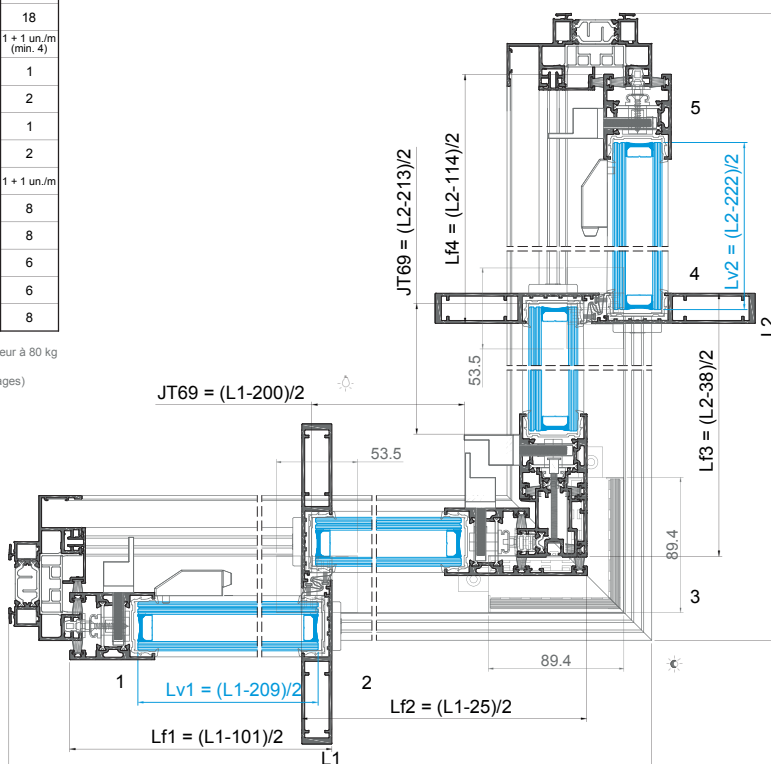
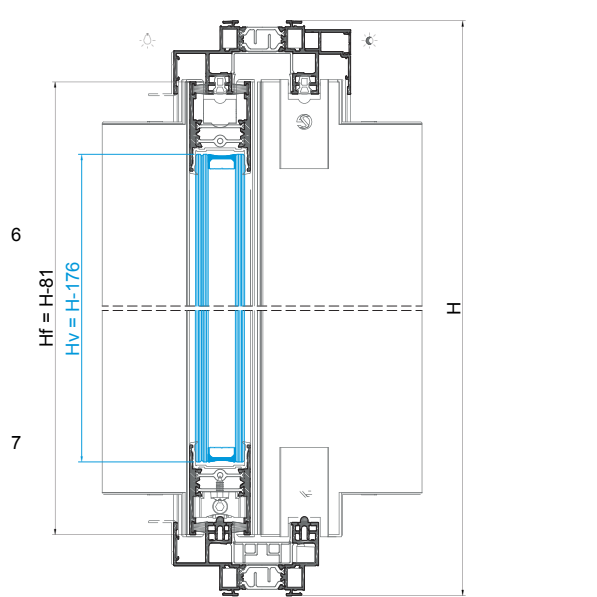



**JANELA / PORTA DE CORRER 2 FOLHAS - PERFIS PT 2RAIL**  
2 SASHES SLIDING WINDOW / DOOR - 2RAIL PT PROFILES  
FENÊTRE / PORTE-FENÊTRE COULISSANT 2 VANTAUX - PROFILÉS PT 2RAIL

PERFIS   PROFILES   PROFILÉS					
CÓDIGO CODE / CODE	DESIGNAÇÃO DESIGNATION / NOMINATION	CORTE HORIZ. HORIZONTAL CUT COUPE HORIZ.	CORTE VERT. VERTICAL CUT COUPE VERTICALE	QUANT. QUANTITY QUANTITE	CORTE CUT COUPE
JT-12	ARO FIXO FIXED FRAME   CADRE DORMANT	L	H	2 + 2	
JT-56	PERFIL CENTRAL CENTRAL PROFILE   PROFILÉ CENTRAL	-	H-74	2	
JT-60	PERFIL LATERAL LATERAL PROFILE   PROFILÉ LATÉRAL	-	H-74	2	
JT-69	TRAVESSA SUP/INF UP/LW TRANSOM   TRAVERSE SUP/INF	(L-153)/2	-	4	
JT-62	PERFIL PINGADEIRA DRIP PROFILE   L'ARMIER	L-4	-	1	
JT-90	CAPA COVER   CAPOT	-	H-37	1	
JT-92	CAPA COVER   CAPOT	-	H-37	1	
JT-87	GUIA GUIDE   GUIDE	L-93	-	2	
208351	JUNTA CENTRAL 2197 CENTRAL JOINT   JOINT CENTRALE	-	H-74	2	
215305	PERFIL PVC U U PROFILE   PROFILÉ PVC U	L-34	H-34	2 + 2	
215303	PERFIL PVC T T PVC PROFILE   PROFILÉ PVC T	(L-116)/2	H-37	2 + 2	

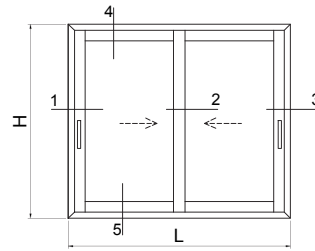

DESEMPENHO DO SISTEMA SYSTEM PERFORMANCE PERFORMANCE DU SYSTÈME	
Permeabilidade ao AR AIR Permeability Perméabilité à l'AIR	4
Estanquidade à ÁGUA WATER Tightness Étanchéité à l'EAU	7A
Resistência ao VENTO WIND Resistance Résistance au VENT	C3 <sup>(a)</sup>   B4 <sup>(b)</sup>

<sup>(a)</sup> Ensaio 1; <sup>(b)</sup> Ensaio 2 | <sup>(a)</sup> Test 1; <sup>(b)</sup> Test 2 | <sup>(a)</sup> Essai 1; <sup>(b)</sup> Essai 2

ACESSÓRIOS   ACCESSORIES   ACCESSOIRES		
CÓDIGO CODE / CODE	DESIGNAÇÃO DESIGNATION / NOMINATION	QUANT. QUANTITY QUANTITE
205000	CARRINHO JT-SLIM ROLLER   ROULETTE	4
213402	CORTA-VENTO JT-SLIM CENTRAL WATERPROOFING PILE SEAL   BROsse CENTRALE D'ÉTANCHÉITÉ	2
212337	CONJ. ESTANQ. CORTA-VENTO JT CENTRAL WATERPROOFING BRUSH KIT   KIT BROsse CENTRALE D'ÉTANCHÉITÉ	1
204153	ESQUADRO JT 11x20,5 CORNER CLEAT   ÉQUERRE	8
213246	CANTO CR S/SB CORNER   ANGLE	4
212131	CONJ. TOPOS LATERAL JT-SLIM LATERAL END-CAPS KIT   KIT D'EMBOUTS LATÉRAUX	2
212133	CONJ. TOPOS CENTRAL JT-SLIM CENTRAL END-CAPS KIT   KIT D'EMBOUTS CENTRAUX	2
210231	TOPO CENTRAL REFORÇADO JT56 28MM 28MM CENTRAL REINFORCED END-CAPS KIT   KIT D'EMBOUTS CENTRAUX RENFORCÉ 28MM	4
210268	GOTEIRA C/ VALV. SVE OUTSIDE FLAP VALVE   CLAPE À VOLET EXTÉRIEUR	(a)
211234	MULTIPONTO ALU MAC-1000 (2P) MULTIPOINT HARDWARE   SERRURE MULTIPOINT	2
202330	CONTRA-FECHO ALU STRIKING PLATE   GÂCHE	4
212455	CONJ. FIX. CONTRA-FECHO AL MULTIP. JT MULTIPOINT HARDWARE STRIKING PLATE FIXING KIT   KIT FIXATION GÂCHE SERRURE MULTIPOINT	4
212289	CONJ. CENTRADOR P/ FERRAGEM ALU CENTRING KIT FOR ALU HARDWARE   KIT CENTRAGE POUR SERRURE ALU	2
212373	CONJ. FIXAÇÃO JT-SLIM FIXING KIT   KIT FIXATION	12
200819	PUXADOR SLIM XS - ESQUERDO LEFT HANDLE   POIGNÉE GAUCHE	1
200817	PUXADOR SLIM XS - DIREITO RIGHT HANDLE   POIGNÉE DROITE	1
212384	CONJ. TOPOS LAT. PINGADEIRA JT82 LATERAL DRIP END-CAPS KIT   KIT D'EMBOUTS LATÉRAUX POUR REJET D'EAU	1
228107	LIMITADOR ABERT. PQ SERIE CORRER OPENING LIMITER   LIMITEUR D'OUVERTURE	1
290087	PARAF. DIN7981 PH 4,8x63 INOX A2 SCREW   VIS	4
290091	PARAFUSO DIN7981 PH 4,8x50 A2 SCREW   VIS	4
290465	PARAF. M5x30 (PARA PUXADOR SLIM XS) SCREW   VIS	4
290051	PARAFUSO AUTO-PERF. CX 4,2X13 A2 (PARA PUXADOR SLIM XS) SCREW   VIS	4
218147	CALÇO REFORÇO HORIZONTAL JT-SLIM * HORIZONTAL REINFORCEMENT SHIM   CALE DE RENFORCEMENT HORIZONTALE	4

\* Usar em folhas com vidros com peso superior a 80kg | To be used in sashes which glass weight exceed 80kg | Utiliser dans des panneaux de verre d'un poids supérieur à 80 kg

(a) Conforme esquemas de drenagem (Capítulo V - Maquinações)

According to drainage schemes (Chapter V - Machinings) | Selon les schémas de drainage (Chapitre V - Usinages)

VEDANTES   SEALS   JOINTS		
CÓDIGO CODE / CODE	DESIGNAÇÃO DESIGNATION / NOMINATION	QUANT. QUANTITY QUANTITE
208348	JUNTA TAPA CANAL 2116 JT JOINT   JOINT	2L + 2H
208099	JUNTA VIDRO U 1032 CX 32MM JT GLAZING GASKET   JOINT DE VITRAGE	2L + 4H
208307	PELÚCIA 7x10 TRI-FIN PRETA PILE SEAL   JOINT BROsse	4L + 6H
208469	PELÚCIA SRF 4X6 2P1M Preta PILE SEAL   JOINT BROsse	2H

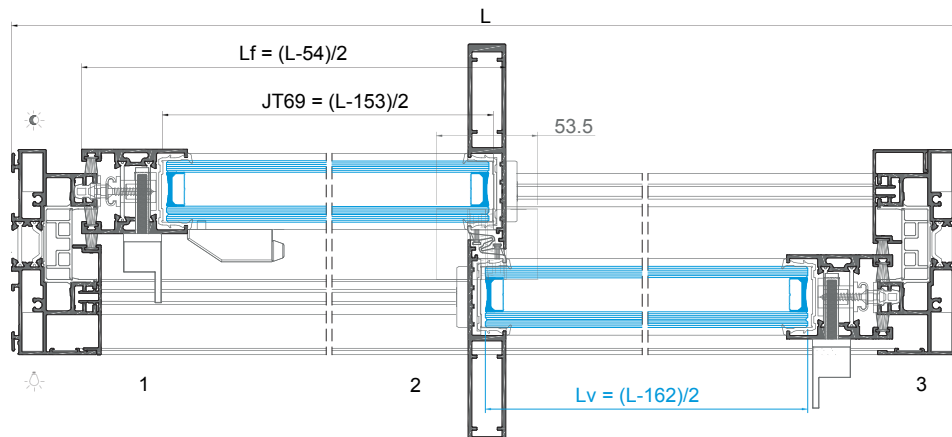
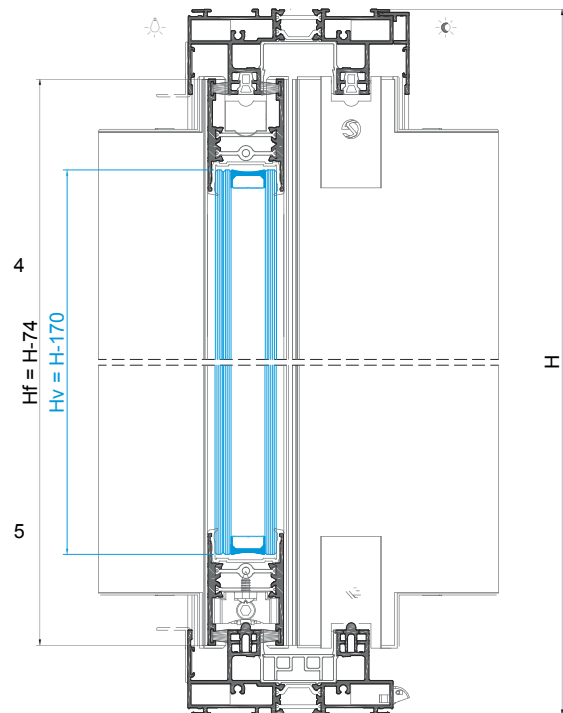

JANELA / PORTA DE CORRER 3 FOLHAS - PERFIS PT 2RAIL  
3 SASHES SLIDING WINDOW / DOOR - 2RAIL PT PROFILES  
FENÊTRE / PORTE-FENÊTRE COULISSANT 3 VANTAUX - PROFILÉS PT 2RAIL

PERFIS   PROFILES   PROFILÉS					
CÓDIGO CODE   CODE	DESIGNAÇÃO DESIGNATION   NOMINATION	CORTE HORIZ. HORIZONTAL CUT COUPE HORIZ.	CORTE VERT. VERTICAL CUT COUPE VERTICALE	QUANT. QUANTITY QUANTITE	CORTE CUT COUPE
JT 12	ARO FIXO FIXED FRAME   CADRE DORMANT	L	H	2 + 2	
JT 56	PERFIL CENTRAL CENTRAL PROFILE   PROFILÉ CENTRAL	-	H-74	4	
JT 60	PERFIL LATERAL LATERAL PROFILE   PROFILÉ LATÉRAL	-	H-74	2	
JT 69	TRAVESSA SUP/INF UP/DOWN TRANSOM   TRAVERSE SUP/INF	(L-147)/3 (L-146)/3	-	4	
JT 62	PERFIL PINGADEIRA DRIP PROFILE   L'ARMIER	L-4	-	1	
JT 90	CAPA COVER   CAPOT	-	H-37	2	
JT 87	GUIA GUIDE   GUIDE	L-96 L-80	-	1	
208351	JUNTA CENTRAL 2197 CENTRAL JOINT   JOINT CENTRALE	-	H-74	4	
215305	PERFIL PVC U U PVC PROFILE   PROFILÉ PVC U	L-34	H-34	2 + 2	
215303	PERFIL PVC T T PVC PROFILE   PROFILÉ PVC T	(L-93)/3 (L-326)/3	H-37	2 + 2	

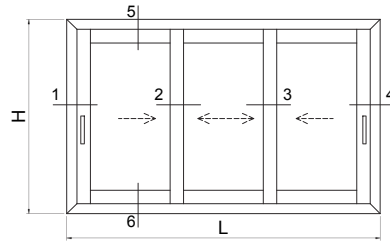

ACESSÓRIOS   ACCESSORIES   ACCESSOIRES		
CÓDIGO CODE   CODE	DESIGNAÇÃO DESIGNATION   NOMINATION	QUANT. QUANTITY QUANTITE
205000	CARRINHO JT-SLIM ROLLER   ROULETTE	6
213402	CORTA-VENTO JT-SLIM CENTRAL WATERPROOFING PILE SEAL   BROSSSE CENTRALE D'ÉTANCHÉITÉ	4
212337	CONJ. ESTANQ. CORTA-VENTO JT CENTRAL WATERPROOFING BRUSH KIT   KIT BROSSSE CENTRALE D'ÉTANCHÉITÉ	2
204153	ESQUADRO JT 11x20.5 CORNER (GLEAT)   ÉQUERRE	8
213246	CANTO CR S/SB CORNER   ANGLE	4
212131	CONJ. TOPOS LATERAL JT-SLIM LATERAL END-CAPS KIT   KIT D'EMBOUITS LATÉRAUX	2
212133	CONJ. TOPOS CENTRAL JT-SLIM CENTRAL END-CAPS KIT   KIT D'EMBOUITS CENTRAUX	4
210231	TOPO CENTRAL REFORÇADO JT56 28MM 28MM CENTRAL REINFORCED END-CAPS KIT   KIT D'EMBOUITS CENTRAUX RENFORCÉ 28MM	8
210268	GOTEIRA C/ VALV. SVE OUTSIDE FLAP VALVE   CLAPE À VOLET EXTERIEUR	(a)
211234	MULTIPONTO ALU MAC. 1000 (2P) MULTIPOINT HARDWARE   SERRURE MULTIPOINT	2
202330	CONTRA-FECHO ALU STRIKING PLATE   GÂCHE	4
212455	CONJ. FIX. CONTRA-FECHO AL MULTIP. JT MULTIPOINT HARDWARE STRIKING PLATE FIXING KIT   KIT FIXATION GÂCHE SERRURE MULTIPOINT	4
212289	CONJ. CENTRADOR P/ FERRAGEM ALU CENTERING KIT FOR ALU HARDWARE   KIT CENTRAGE POUR SERRURE ALU	2
212373	CONJ. FIXAÇÃO JT-SLIM FIXING KIT   KIT FIXATION	12
200819	PUXADOR SLIM XS - ESQUERDO LEFT HANDLE   POIGNÉE GAUCHE	1
200817	PUXADOR SLIM XS - DIREITO RIGHT HANDLE   POIGNÉE DROITE	1
212384	CONJ. TOPOS LAT. PINGADEIRA JT82 LATERAL DRIP END-CAPS KIT   KIT D'EMBOUITS LATÉRAUX POUR REJET D'EAU	1
228107	LIMITADOR ABERT. PQ SERIE CORRER OPENING LIMITER   LIMITÉUR D'OUVERTURE	2
290087	PARAF. DIN7981 PH 4,8x63 INOX A2 SCREW   VIS	4
290091	PARAFUSO DIN7981 PH 4,8x50 A2 SCREW   VIS	8
290465	PARAF. M5x30 (PARA PUXADOR SLIM XS) SCREW   VIS	4
290051	PARAFUSO AUTO-PERF. CX 4,2x13 A2 (PARA PUXADOR SLIM XS) SCREW   VIS	4
218147	CALÇO REFORÇO HORIZONTAL JT-SLIM * HORIZONTAL REINFORCEMENT SHIM   CALE DE RENFORCEMENT HORIZONTALE	6

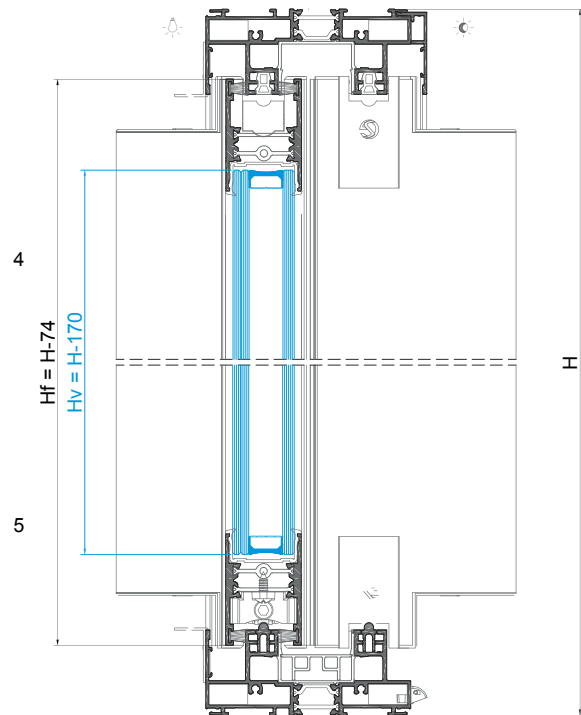

\* Usar em folhas com vidros com peso superior a 80kg  
To be used in sashes which glass weight exceed 80kg | Utiliser dans des panneaux de verre d'un poids supérieur à 80 kg  
(a) Conforme esquemas de drenagem (Capítulo V - Maquinações)  
According to drainage schemes (Chapter V - Machinings) | Selon les schémas de drainage (Chapitre V - Usinages)

VEDANTES   SEALS   JOINTS		
CÓDIGO CODE   CODE	DESIGNAÇÃO DESIGNATION   NOMINATION	QUANT. QUANTITY QUANTITE
208348	JUNTA TAPA CANAL 2116 JT JOINT   JOINT	2L + 2H
208099	JUNTA VIDRO U 1032 CX 32MM JT GLAZING GASKET   JOINT DE VITRAGE	2L + 6H
208307	PELÚCIA 7x10 TRI-FIN PRETA PILE SEAL   JOINT BROSSSE	4L + 6H
208469	PELÚCIA SRF 4X8 2P1M Preta PILE SEAL   JOINT BROSSSE	4H

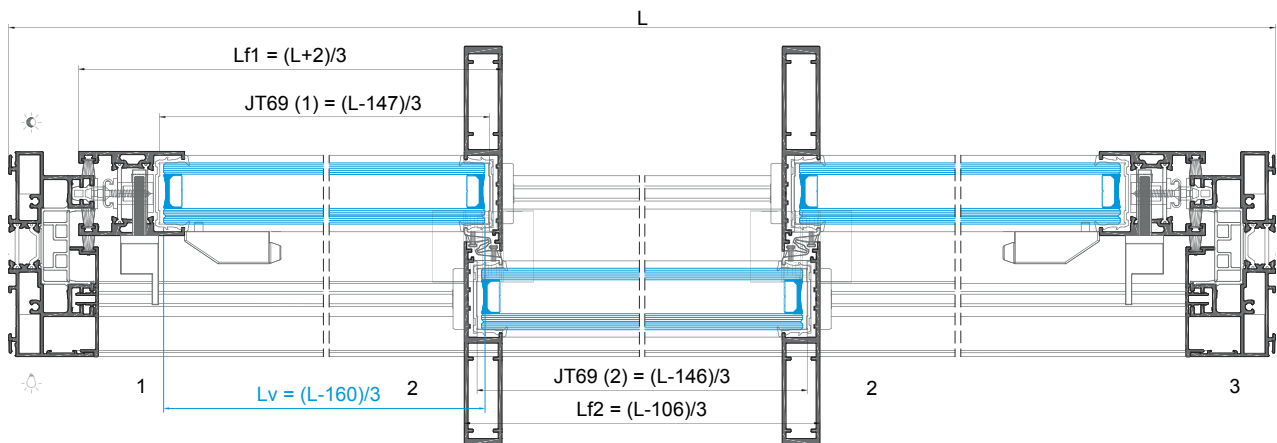

**JANELA DE CORRER 4 FOLHAS 2-RAIL COM LIGAÇÃO CENTRAL - LINHA PT**  
4 SASHES 2-RAIL SLIDING WINDOW WITH CENTRAL CONNECTION - PT LINE  
FENÊTRE COULISSANT 4 VANTAUX 2-RAIL AVEC CONNEXION CENTRALE - LIGNE PT

PERFIS   PROFILES   PROFILÉS					
CÓDIGO CODE   CODE	DESIGNAÇÃO DESIGNATION   NOMINATION	CORTE HORIZ. HORIZONTAL CUT COUPE HORIZ.	CORTE VERT. VERTICAL CUT COUPE VERTICALE	QUANT. QUANTITY QUANTITÉ	CORTE CUT COUPE
JT 12	ARO FIXO FIXED FRAME   CADRE DORMANT	L	H	2 + 2	
JT 56	PERFIL CENTRAL CENTRAL PROFILE   PROFILÉ CENTRAL	-	H-74	4	
JT 60	PERFIL LATERAL LATERAL PROFILE   PROFILÉ LATÉRAL	-	H-74	4	
JT 69	TRAVESSA SUP/INF UP/LW TRANSOM   TRAVERSE SUP/INF	(L-235)/4	-	8	
JT 71	PERFIL LIGAÇÃO CENTRAL CONNECTION PROFILE   PROFILÉ DE LIAISON	-	H-134	1	
JT 82	PERFIL PINGADEIRA DRIP PROFILE   L'ARMIER	L-4	-	1	
JT 90	CAPA GUIDE   CAPOT	-	H-37	2	
JT 87	GUIA GUIDE   GUIDE	L-96 L-90	-	1	
208351	JUNTA CENTRAL 2197 CENTRAL JOINT   JOINT CENTRALE	-	H-74	4	
215305	PERFIL PVC U UPVC PROFILE   PROFILÉ PVC U	L-34	H-34	2 + 2	
215303	PERFIL PVC T PVC PROFILE   PROFILÉ PVC T	(L-173)/4 (L-280)/4	H-37	2 + 2	

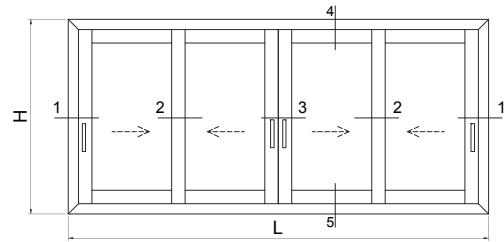

ACESSÓRIOS   ACCESSORIES   ACCESSOIRES		
CÓDIGO CODE   CODE	DESIGNAÇÃO DESIGNATION   NOMINATION	QUANT. QUANTITY QUANTITÉ
205000	CARRINHO JT-SLIM ROLLER   ROULETTE	8
213402	CORTA-VENTO JT-SLIM CENTRAL WATERPROOFING BRUSH   BROSSE CENTRALE D'ÉTANCHÉITÉ	6
212337	CONJ. ESTANQ. CORTA-VENTO JT CENTRAL WATERPROOFING BRUSH KIT   KIT BROSSE CENTRALE D'ÉTANCHÉITÉ	3
204153	ESQUADRO JT 11x20.5 CORNER CLEAT   ÉQUERRE	8
213246	CANTO CR S/SB CORNER   ANGLE	4
212131	CONJ. TOPOS LATERAL JT-SLIM LATERAL END-CAPS KIT   KIT D'EMBOUTS LATÉRAUX	4
212133	CONJ. TOPOS CENTRAL JT-SLIM CENTRAL END-CAPS KIT   KIT D'EMBOUTS CENTRAUX	4
210231	TOPO CENTRAL REFORÇADO JT56 28MM 28MM CENTRAL REINFORCED END-CAPS KIT   KIT D'EMBOUTS CENTRAUX RENFORCÉ 28MM	8
212135	CONJ. TOPOS LIG. 2 FOLHAS JT-SLIM 2 SASHES CONNECTING END-CAPS KIT   KIT D'EMBOUTS CONNEXION 2 VANTAUX	1
210268	GOTEIRA O VALV. SVE OUTSIDE FLAP VALVE   GLAISE À VOLET EXTÉRIEUR	(a)
211234	MULTIPONTO ALU MAC.1000 (2P) MULTIPOINT HARDWARE   SERRURE MULTIPONT	3
202330	CONTRA-FECHO ALU STRIKING PLATE   GÂCHE	4
212455	CONJ. FIX. CONTRA-FECHO AL MULTIP. JT MULTIPOINT HARDWARE STRIKING PLATE FIXING KIT   KIT FIXATION GÂCHE SERRURE MULTIPONT	4
202331	CONTRA-FECHO Nº2 2F/90° ALU STRIKING PLATE   GÂCHE	2
212458	CONJ. FIX. CONTRA-FECHO MULTIP. 2F/90° JT MULTIPOINT HARDWARE STRIKING PLATE FIXING KIT   KIT FIXATION GÂCHE SERRURE MULTIP.	2
212289	CONJ. CENTRADOR P/ FERRAGEM ALU CENTERING KIT FOR ALU HARDWARE   KIT CENTRAGE POUR SERRURE ALU	2
212291	CONJ. CENTRADOR P/ FERRAGEM ALU PERFIL LIG. CENTERING KIT FOR ALU HARDWARE   KIT CENTRAGE POUR SERRURE ALU	1
212373	CONJ. FIXAÇÃO JT-SLIM FIXING KIT   KIT FIXATION	18
212017	CONJ. FIX. FERRAGEM MULTIP. MULTIPOINT HARDWARE FIXING KIT   KIT FIXATION POUR SERRURE MULTIPONT	1 + 1 un./m (min. 4)
200819	PUXADOR SLIM XS - ESQUERDO LEFT HANDLE   POIGNÉE GAUCHE	1
200817	PUXADOR SLIM XS - DIREITO RIGHT HANDLE   POIGNÉE DROITE	2
200057	PUXADOR FOLHA PASSIVA SLIM XS PASSIVE SASH HANDLE   POIGNÉE VENTAIL PASSIVE	1
212384	CONJ. TOPOS LAT. PINGADEIRA JT82 LATERAL DRIP END-CAPS KIT   KIT D'EMBOUTS LATÉRAUX POUR REJET D'EAU	1
228107	LIMITADOR ABERT. PQ SERIE CORRER OPENING LIMITER   LIMITEUR D'OUVERTURE	2
290087	PARAF. DIN7981 PH 4,8x63 INOX A2 SCREW   VIS	8
290091	PARAFUSO DIN7981 PH 4,8x50 A2 SCREW   VIS	8
290465	PARAF. M5x30 (PARA PUXADOR SLIM XS) SCREW   VIS	6
290051	PARAFUSO AUTO-PERF. CX 4,2x13 A2 (PARA PUXADOR SLIM XS) SCREW   VIS	6
218147	CALÇO REFORÇO HORIZONTAL JT-SLIM * HORIZONTAL REINFORCEMENT SHIM   CALE DE RENFORCEMENT HORIZONTALE	8

\* Usar em folhas com vidros com peso superior a 80kg  
To be used in sashes with glass weight exceed 80kg | Utiliser dans des panneaux de verre d'un poids supérieur à 80 kg  
(a) Conforme esquemas de drenagem (Capítulo V - Maquinações)  
According to drainage schemes (Chapter V - Usinages) | Selon les schémas de drainage (Chapitre V - Usinages)

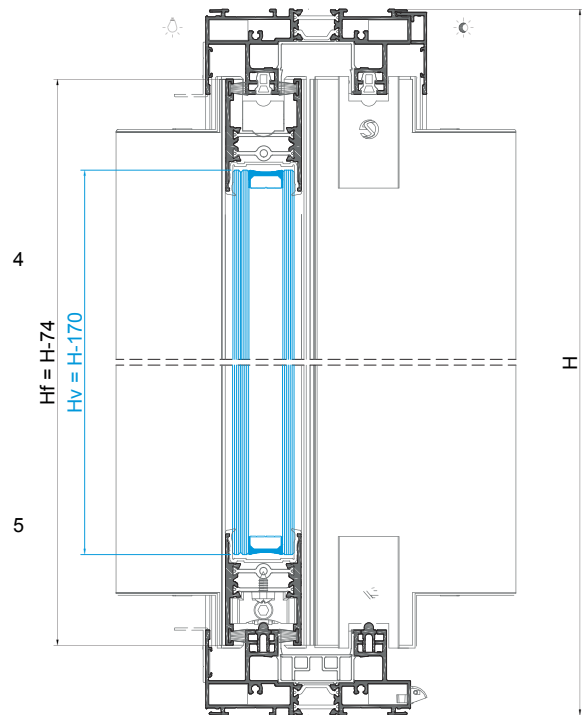

VEDANTES   SEALS   JOINTS		
CÓDIGO CODE   CODE	DESIGNAÇÃO DESIGNATION   NOMINATION	QUANT. QUANTITY QUANTITÉ
208348	JUNTA TAPA CANAL 2116 JT JOINT   JOINT	2L + 2H
208099	JUNTA VIDRO U 1032 CX 32MM JT GLAZING GASKET   JOINT DE VITRAGE	2L + 2H
208307	PELUCIA 7x10 TRI-FIN PRETA PILE SEAL   JOINT BROSSE	4L + 10H
208479	JUNTA TAPA CANAL PERFIL LIG. 2117 JT JOINT   JOINT	H
208469	PELUCIA SRF 4X8 2P1M Preta PILE SEAL   JOINT BROSSE	4H

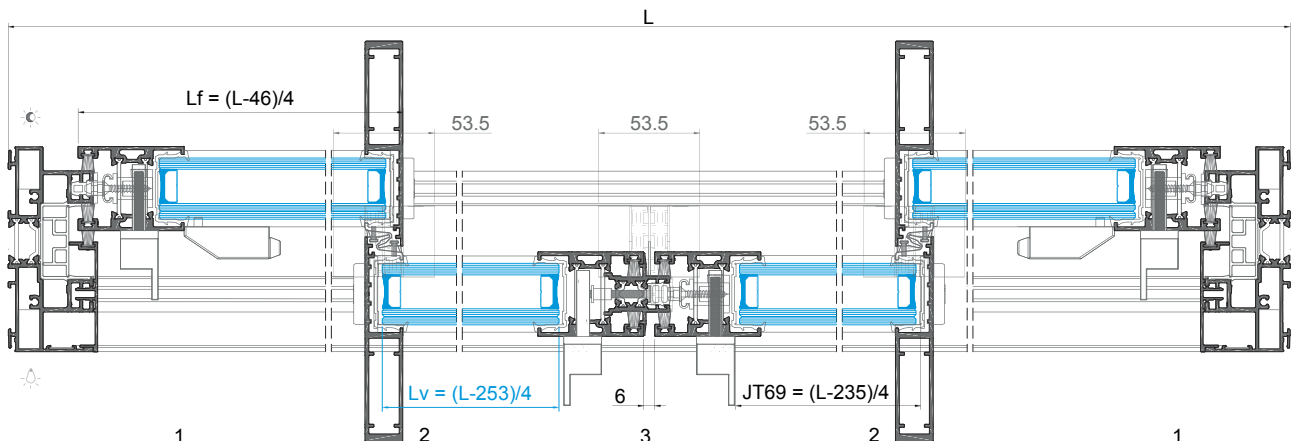

**JANELA DE CORRER 4 FOLHAS 2-RAIL CANTO 90° - LINHA PT**  
4 SASHES 2-RAIL SLIDING WINDOW 90° CORNER - PT LINE  
FENÊTRE COULISSANT 4 VANTAUX 2-RAIL À ANGLE 90° - LIGNE PT

PERFIS   PROFILES   PROFILÉS					
CÓDIGO CODE   CODE	DESIGNAÇÃO DESIGNATION   NOMINATION	CORTE HORIZ. HORIZONTAL CUT COUPE HORIZ.	CORTE VERT. VERTICAL CUT COUPE VERTICALE	QUANT. QUANTITY QUANTITE	CORTE CUT COUPE
JT 12	ARO FIXO FIXED FRAME   CADRE DORMANT	L1 L2	H	2 + 2	
JT 56	PERFIL CENTRAL CENTRAL PROFILE   PROFILÉ CENTRAL	-	H-74	4	
JT 60	PERFIL LATERAL LATERAL PROFILE   PROFILÉ LATÉRAL	-	H-74	2	
JT 70	PERFIL LATERAL CANTO 90° 90° CORNER LAT. PR. IPR. LAT. D'ANGLE À 90°	-	H-74	2	
JT 69	TRAVESSA SUP/INF UP/LW TRANSOM   TRAVERSE SUP/INF	(L1-208)/2 (L2-222)/4	-	4 4	
JT 72	PERFIL LIGAÇÃO CANTO 90° CONNECTION PROFILE   PROFILÉ DE LIAISON	-	H-134	1	
JT 82	PERFIL PINGADEIRA DRIP PROFILE   L'ARMIER	L1+19 L2+19	-	1 1	
JT 90	CAPA COVER   CAPOT	-	H-37	2	
JT 87	GUIA GUIDE   GUIDE	L1-48 L1-106 L2-46 L2-106	-	1 1 1 1	
208351	JUNTA CENTRAL 2197 CENTRAL JOINT   JOINT CENTRALE	-	H-74	4	
215305	PERFIL PVC U U PVC PROFILE   PROFILÉ PVC U	L1-34 L2-34	H-34	2 + 2	
215303	PERFIL PVC T T PVC PROFILE   PROFILÉ PVC T	(L1-175)/2 (L1-238)/2 (L2-224)/2 (L2-188)/2	H-37	1 1 + 2 1 1	

VEDANTES   SEALS   JOINTS		
CÓDIGO CODE   CODE	DESIGNAÇÃO DESIGNATION   NOMINATION	QUANT. QUANTITY QUANTITE
208348	JUNTA TAPA CANAL 2116 JT JOINT   JOINT	2L1 + 2H
208099	JUNTA VIDRO U 1032 CX 32MM JT GLAZING GASKET   JOINT DE IVTRAGE	2L1 + 8H 2L2
208307	PELÚCIA 7x10 TRI-FIN PRETA PILE SEAL   JOINT BRUSSE	4L1 + 11H 4L2
208479	JUNTA TAPA CANAL PERFIL LIG. 2117 JT JOINT   JOINT	H
208435	JUNTA VD 2415 JOINT   JOINT	H
208469	PELÚCIA SRF 4X8 2P1M Preta PILE SEAL   JOINT BRUSSE	4H

ACESSÓRIOS   ACCESSORIES   ACCESSOIRES		
CÓDIGO CODE   CODE	DESIGNAÇÃO DESIGNATION   NOMINATION	QUANT. QUANTITY QUANTITE
205000	CARRINHO JT-SLIM ROLLER   ROULETTE	8
213402	CORTA-VENTO JT-SLIM CENTRAL WATERPROOFING BRUSH   BRUSSE CENTRALE D'ÉTANCHÉITÉ	4
213287	CORTA-VENTO CANTO 90° JT 90° CORNER WATERPROOFING BRUSH   BRUSSE D'ÉTANCHÉITÉ ANGLE 90°	2
212337	CONJ. ESTANQ. CORTA-VENTO JT CENTRAL WATERPROOFING BRUSH KIT   KIT BRUSSE CENTRALE D'ÉTANCHÉITÉ	4
204153	ESQUADRO JT 11x20.5 CORNER CLEAT   ÉQUERRE	8
212243	CONJ. UNIÃO CANTO 90° JT 90° CORNER UNION KIT   KIT D'UNION ANGLE 90°	1
204389	ESQUADRO INOX CANTO 90° 90° STAINLESS STEEL CORNER   ANGLE EN ACIER INOXYDABLE 90°	2
213246	CANTO CR S/SB CORNER   ANGLE	4
212131	CONJ. TOPOS LATERAL JT-SLIM LATERAL END-CAPS KIT   KIT D'EMBOÛTS LATÉRAUX	4
212133	CONJ. TOPOS CENTRAL JT-SLIM CENTRAL END-CAPS KIT   KIT D'EMBOÛTS CENTRAUX	4
210231	TOPO CENTRAL REFORÇADO JT56 28MM 28MM CENTRAL REINFORCED END-CAPS KIT   KIT D'EMBOÛTS CENTRAUX RENFORCÉ 28MM	8
212151	CONJ. TOPOS CANTO 90° JT-SLIM 90° CORNER END-CAPS KIT   KIT D'EMBOÛTS POUR ANGLE 90°	1
210268	GOTEIRA C/ VALV. SVE OUTSIDE FLAP VALVE   CLAPE À VOLET EXTÉRIEUR	(a)
211234	MULTIPONTO ALU MAG. 1000 (2P) MULTIPOINT HARDWARE   SERRURE MULTIPONT	3
202330	CONTRA-FECHO ALU STRIKING PLATE   GÂCHE	4
212455	CONJ. FIX. CONTRA-FECHO AL MULTIP. JT MULTIPOINT HARDWARE STRIKING PLATE FIXING KIT   KIT FIXATION GÂCHE SERRURE MULTIPONT	4
202331	CONTRA-FECHO Nº2 2F/90° ALU STRIKING PLATE   GÂCHE	2
212458	CONJ. FIX. CONTRA-FECHO MULTIP. 2F/90° JT MULTIPOINT HARDWARE STRIKING PLATE FIXING KIT   KIT FIXATION GÂCHE SERRURE MULTIP.	2
212289	CONJ. CENTRADOR P/ FERRAGEM ALU CENTERING KIT FOR ALU HARDWARE   KIT CENTRAGE POUR SERRURE ALU	2
212291	CONJ. CENTRADOR P/ FERRAGEM ALU PERFIL LIG. CENTERING KIT FOR ALU HARDWARE   KIT CENTRAGE POUR SERRURE ALU	1
212373	CONJ. FIXAÇÃO JT-SLIM FIXING KIT   KIT FIXATION	18
212079	CONJ. FIX. FERRAGEM MULTIP. JT72 MULTIPOINT FIXING KIT   KIT FIXATION SERRURE MULTIPONT	1 + 1 un./m (min. 4)
200819	PUXADOR SLIM XS - ESQUERDO LEFT HANDLE   POIGNÉE GAUCHE	1
200817	PUXADOR SLIM XS - DIREITO RIGHT HANDLE   POIGNÉE DROITE	2
212384	CONJ. TOPOS LAT. PINGADEIRA JT82 LATERAL DRIP END-CAPS KIT   KIT D'EMBOÛTS LATÉRAUX POUR REJET D'EAU	1
228107	LIMITADOR ABERT. PQ SERIE CORRER OPENING LIMITER   LIMITEUR D'OUVERTURE	2
290087	PARAF. DIN7981 PH 4,8x63 INOX A2 SCREW   VIS	8
290091	PARAFUSO DIN7981 PH 4,8x50 A2 SCREW   VIS	8
290465	PARAF. M5x30 (PARA PUXADOR SLIM XS) SCREW   VIS	6
290051	PARAFUSO AUTO-PERF. CX 4,2x13 A2 (PARA PUXADOR SLIM XS) SCREW   VIS	6
218147	CALÇO REFORÇO HORIZONTAL JT-SLIM * HORIZONTAL REINFORCEMENT SHIM   CALE DE RENFORCEMENT HORIZONTALE	8

\* Usar em folhas com vidros com peso superior a 80kg  
To be used in sashes which glass weight exceed 80kg | Utiliser dans des panneaux de verre d'un poids supérieur à 80 kg  
(a) Conforme esquemas de drenagem (Capítulo V - Maquinações)  
According to drainage schemes (Chapter V - Machinings) | Selon les schémas de drainage (Chapitre V - Usinages)

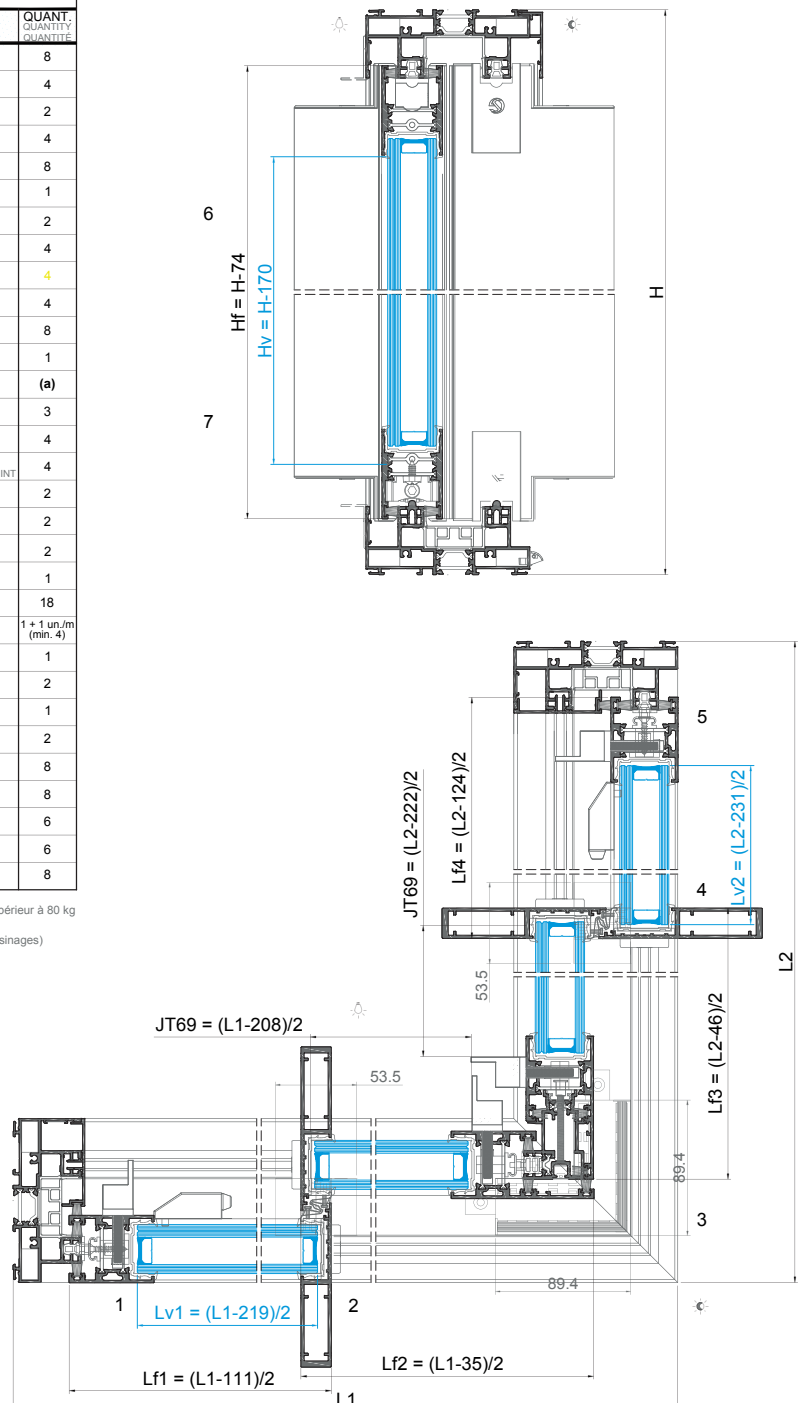

**JANELA / PORTA DE CORRER 3 FOLHAS - PERFIS PT 3RAIL**  
3 SASHES SLIDING WINDOW / DOOR - 3RAIL PT PROFILES  
FENÊTRE / PORTE-FENÊTRE COULISSANT 3 VANTAUX - PROFILÉS PT 3RAIL

PERFIS   PROFILES   PROFILÉS					
CÓDIGO CODE   CODE	DESIGNAÇÃO DESIGNATION   NOMINATION	CORTE HORIZ. HORIZONTAL CUT COUPE HORIZ.	CORTE VERT. VERTICAL CUT COUPE VERTICALE	QUANT. QUANTITY QUANTITÉ	CORTE CUT COUPE
JT 13	ARO FIXO FIXED FRAME   CADRE DORMANT	L	H	2 + 2	
JT 56	PERFIL CENTRAL CENTRAL PROFILE   PROFILÉ CENTRAL	-	H-74	4	
JT 60	PERFIL LATERAL LATERAL PROFILE   PROFILÉ LATÉRAL	-	H-74	2	
JT 69	TRAVESSA SUP/INF UP/LW TRANSOM   TRAVERSE SUP/INF	(L-147)/3 (L-146)/3	-	4 2	
JT 82	PERFIL PINGADEIRA DRIP PROFILE   L'ARMIER	L-4	-	1	
JT 90	CAPA COVER   CAPOT	-	H-37	1	
JT 91	CAPA COVER   CAPOT	-	H-51	2	
JT 92	CAPA COVER   CAPOT	-	H-37	1	
JT 87	GUIA GUIDE   GUIDE	L-93 L-96	-	2 1	
208351	JUNTA CENTRAL 2197 CENTRAL JOINT   JOINT-CENTRALE	-	H-74	4	
215305	PERFIL PVC U U PVC PROFILE   PROFILÉ PVC U	L-34	H-34	4 + 4	
215303	PERFIL PVC T T PVC PROFILE   PROFILÉ PVC T	(L-93)/3 (2L-259)/3	H-37	2 + 4	

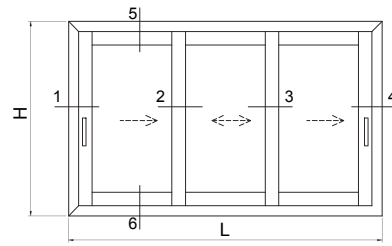

ACESSÓRIOS   ACCESSORIES   ACCESSOIRES			
CÓDIGO CODE   CODE	DESIGNAÇÃO DESIGNATION   NOMINATION	QUANT. QUANTITY QUANTITÉ	
205000	CARRINHO JT-SLIM ROLLER   ROULETTE	6	
213402	CORTA-VENTO JT-SLIM CENTRAL WATERPROOFING PILE SEAL   BROSSSE CENTRALE D'ETANCHÉITE	4	
212337	CONJ. ESTANQ. CORTA-VENTO JT CENTRAL WATERPROOFING BRUSH KIT   KIT BROSSSE CENTRALE D'ETANCHÉITE	2	
204153	ESQUADRO JT 11x20.5 CORNER CLEAT   ÉQUERRE	8	
213246	CANTO CR S/SB CORNER   ANGLE	4	
212131	CONJ. TOPOS LATERAL JT-SLIM LATERAL END-CAPS KIT   KIT D'EMBOUTS LATÉRAUX	2	
212133	CONJ. TOPOS CENTRAL JT-SLIM CENTRAL END-CAPS KIT   KIT D'EMBOUTS CENTRAUX	4	
210231	TOPO CENTRAL REFORÇADO JT56 28MM 28MM CENTRAL REINFORCED END-CAPS KIT   KIT D'EMBOUTS CENTRAUX RENFORCÉ 28MM	8	
210268	GOTEIRA C/ VALV. SVE OUTSIDE FLAP VALVE   CLAPE À VOLET EXTÉRIEUR	(a)	
211234	MULTIPONTO ALU MAC.1000 (2P) MULTIPOINT HARDWARE   SERRURE MULTIPONT	2	
202330	CONTRA-FECHO ALU STRIKING PLATE   GÂCHE	4	
212455	CONJ. FIX. CONTRA-FECHO AL MULTIP. JT MULTIPOINT HARDWARE STRIKING PLATE FIXING KIT   KIT FIXATION GÂCHE SERRURE MULTIPONT	4	
212289	CONJ. CENTRADOR P/ FERRAGEM ALU CENTERING KIT FOR ALU HARDWARE   KIT CENTRAGE POUR SERRURE ALU	2	
212373	CONJ. FIXAÇÃO JT-SLIM FIXING KIT   KIT FIXATION	12	
200819	PUXADOR SLIM XS - ESQUERDO LEFT HANDLE   POIGNEE GAUCHE	1	
200817	PUXADOR SLIM XS - DIREITO RIGHT HANDLE   POIGNEE DROITE	1	
212384	CONJ. TOPOS LAT. PINGADEIRA JT82 LATERAL DRIP END-CAPS KIT   KIT D'EMBOUTS LATÉRAUX POUR REJET D'EAU	1	
228107	LIMITADOR ABERT. PQ SERIE CORRER OPENING LIMITER   LIMITEUR D'OUVERTURE	1	
290087	PARAF. DIN7981 PH 4,8x63 INOX A2 SCREW   VIS	4	
290091	PARAFUSO DIN7981 PH 4,8x50 A2 SCREW   VIS	8	
290465	PARAF. M5x30 (PARA PUXADOR SLIM XS) SCREW   VIS	4	
290051	PARAFUSO AUTO-PERF. CX 4,2x13 A2 (PARA PUXADOR SLIM XS) SCREW   VIS	4	
218147	CALÇO REFORÇO HORIZONTAL JT-SLIM * HORIZONTAL REINFORCEMENT SHIM   CALE DE RENFORCEMENT HORIZONTALE	6	

\* Usar em folhas com vidros com peso superior a 80kg  
To be used in sashes which glass weight exceed 80kg | Utiliser dans des panneaux de verre d'un poids supérieur à 80 kg  
(a) Conforme esquemas de drenagem (Capítulo V - Maquinações)  
According to drainage schemes (Chapter V - Machinings) | Selon les schémas de drainage (Chapitre V - Usinages)

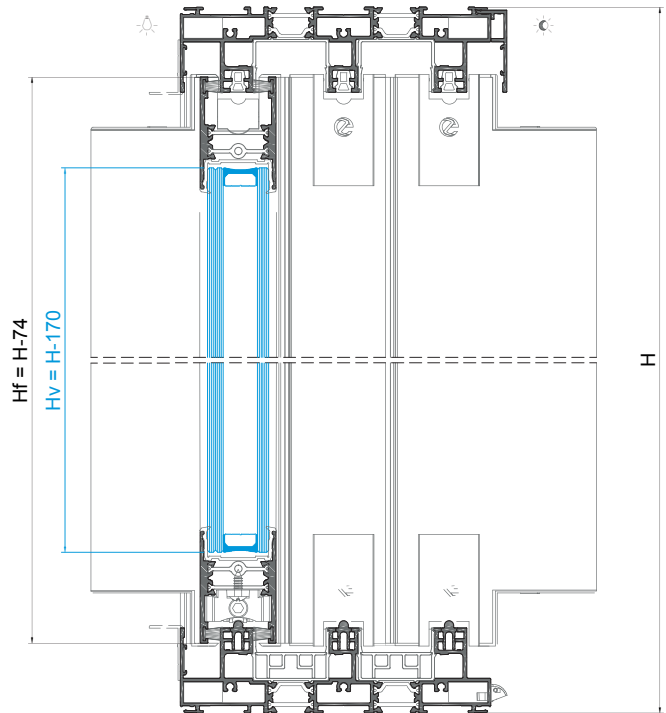

VEDANTES   SEALS   JOINTS			
CÓDIGO CODE   CODE	DESIGNAÇÃO DESIGNATION   NOMINATION	QUANT. QUANTITY QUANTITÉ	
208348	JUNTA TAPA CANAL 2116 JT JOINT   JOINT	3L + 2H	
208099	JUNTA VIDRO U 1032 CX 32MM JT GLAZING GASKET   JOINT DE VITRAGE	2L + 6H	
208307	PELÚCIA 7x10 TRI-FIN PRETA PILE SEAL   JOINT BROSSSE	4L + 6H	
208469	PELÚCIA SRF 4X8 2P1M Preta PILE SEAL   JOINT BROSSSE	4H	

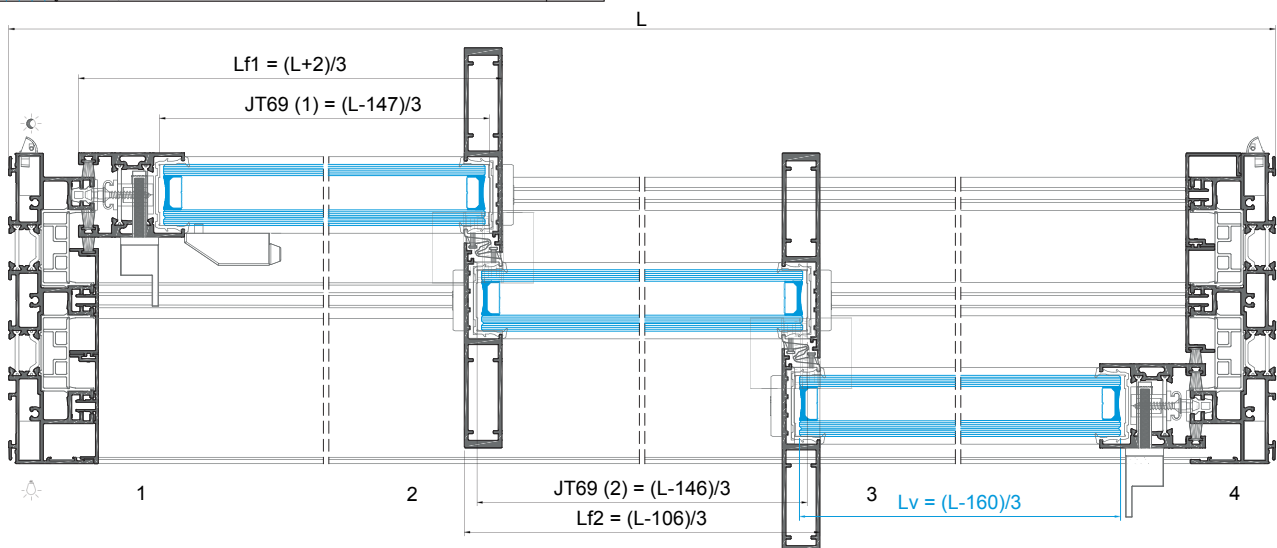



**JANELA / PORTA DE CORRER 4 FOLHAS - PERFIS PT 4RAIL**  
4 SASHES SLIDING WINDOW / DOOR - 4RAIL PT PROFILES  
FENÊTRE / PORTE-FENÊTRE COULISSANT 4 VANTAOX - PROFILÉS PT 4RAIL

PERFIS   PROFILES   PROFILÉS					
CÓDIGO CODE   CODE	DESIGNAÇÃO DESIGNATION   NOMINATION	CORTE HORIZ. HORIZONTAL CUT COUPE HORIZ.	CORTE VERT. VERTICAL CUT COUPE VERTICALE	QUANT. QUANTITY QUANTITE	CORTE CUT COUPE
JT 34	ARO FIXO FIXED FRAME   CADRE DORMANT	L	H	2 + 2	
JT 56	PERFIL CENTRAL CENTRAL PROFILE   PROFILÉ CENTRAL	-	H-74	6	
JT 60	PERFIL LATERAL LATERAL PROFILE   PROFILÉ LATÉRAL	-	H-74	2	
JT 69	TRAVESSA SUP/INF UP/LW TRANSOM   TRAVERSE SUP/INF	(L-140)/4 (L-139)/4	-	4 4	
JT 90	CAPA COVER   CAPOT	-	H-37	2	
JT 91	CAPA COVER   CAPOT	-	H-51	4	
JT 87	GUIA GUIDE   GUIDE	L-93 L-96	-	2	
208351	JUNTA CENTRAL 2197 CENTRAL JOINT   JOINT CENTRALE	-	H-74	6	
215305	PERFIL PVC U U PVC PROFILE   PROFILÉ PVC U	L-34	H-34	6 + 6	
215303	PERFIL PVC T T PVC PROFILE   PROFILÉ PVC T	(L-70)/4 (3L-401)/4 (L-118)/2	H-37	2 2 + 6	

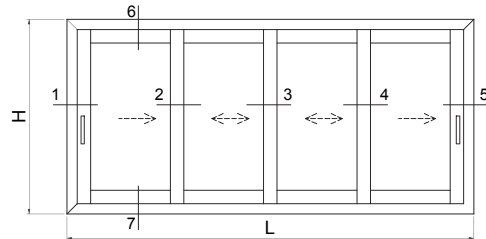

ACESSÓRIOS   ACCESSORIES   ACCESSOIRES		
CÓDIGO CODE   CODE	DESIGNAÇÃO DESIGNATION   NOMINATION	QUANT. QUANTITY QUANTITE
205000	CARRINHO JT-SLIM ROLLER   ROULETTE	8
213402	CORTA-VENTO JT-SLIM CENTRAL WATERPROOFING PILE SEAL   BROSSSE CENTRALE D'ÉTANCHÉITÉ	6
212337	CONJ. ESTANQ. CORTA-VENTO JT CENTRAL WATERPROOFING BRUSH KIT   KIT BROSSSE CENTRALE D'ÉTANCHÉITÉ	3
204153	ESQUADRO JT 11x20.5 CORNER GLAZE   LÉGIÈRE	8
213246	CANTO CR S/SB CORNER   ANGLE	8
212131	CONJ. TOPOS LATERAL JT-SLIM LATERAL END-CAPS KIT   KIT D'EMBOUTS LATÉRAUX	2
212133	CONJ. TOPOS CENTRAL JT-SLIM CENTRAL END-CAPS KIT   KIT D'EMBOUTS CENTRAUX	6
210231	TOPO CENTRAL REFORÇADO JT56 28MM 28MM CENTRAL REINFORCED END-CAPS KIT   KIT D'EMBOUTS CENTRAUX RENFORCÉ 28MM	12
210268	GOTEIRA C/ VALV. SVE OUTSIDE FLAP VALVE   CLAPE À VOLET EXTÉRIEUR	(a)
211234	MULTIPONTO ALU MAC.1000 (2P) MULTIPOINT HARDWARE   SERRURE MULTIPONT	2
202330	CONTRA-FECHO ALU STRIKING PLATE   GÂCHE	4
212455	CONJ. FIX. CONTRA-FECHO AL MULTIP. JT MULTIPOINT HARDWARE STRIKING PLATE FIXING KIT   KIT FIXATION GÂCHE SERRURE MULTIPONT	4
212289	CONJ. CENTRADOR P/ FERRAGEM ALU CENTERING KIT FOR ALU HARDWARE   KIT CENTRAGE POUR SERRURE ALU	2
212373	CONJ. FIXAÇÃO JT-SLIM FIXING KIT   FIXATION	12
200819	PUXADOR SLIM XS - ESQUERDO LEFT HANDLE   POIGNÉE GAUCHE	1
200817	PUXADOR SLIM XS - DIREITO RIGHT HANDLE   POIGNÉE DROITE	1
228107	LIMITADOR ABERT. PQ SERIE CORRER OPENING LIMITER   LIMITEUR D'OUVERTURE	1
290087	PARAF. DIN7981 PH 4,8x63 INOX A2 SCREW   VIS	4
290091	PARAFUSO DIN7981 PH 4,8x50 A2 SCREW   VIS	12
290465	PARAF. M5x30 (PARA PUXADOR SLIM XS) SCREW   VIS	4
290051	PARAFUSO AUTO-PERF. CX 4,2x13 A2 (PARA PUXADOR SLIM XS) SCREW   VIS	4
218147	CALÇO REFORÇO HORIZONTAL JT-SLIM * HORIZONTAL REINFORCEMENT SHIM   CALE DE RENFORCEMENT HORIZONTALE	8

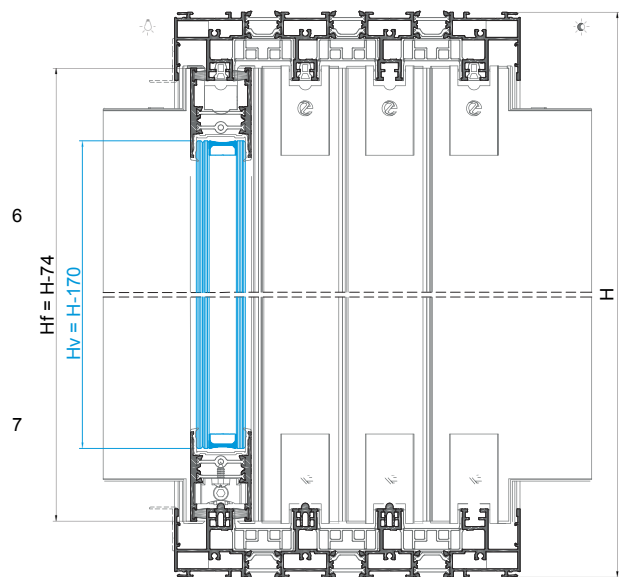

\* Usar em folhas com vidros com peso superior a 80kg  
To be used in sashes which glass weight exceed 80kg | Utiliser dans des panneaux de verre d'un poids supérieur à 80 kg  
(a) Conforme esquemas de drenagem (Capítulo V - Maquinações)  
According to drainage schemes (Chapter V - Machinings) | Selon les schémas de drainage (Chapitre V - Usinages)

VEDANTES   SEALS   JOINTS		
CÓDIGO CODE   CODE	DESIGNAÇÃO DESIGNATION   NOMINATION	QUANT. QUANTITY QUANTITE
208348	JUNTA TAPA CANAL 2116 JT JOINT   JOINT	4L + 2H
208099	JUNTA VIDRO U 1032 CX 32MM JT GLAZING GASKET   JOINT DE VITRAGE	2L + 8H
208307	PELÚCIA 7x10 TRI-FIN PRETA PILE SEAL   JOINT BROSSSE	4L + 6H
208469	PELÚCIA SRF 4X8 2P1M Preta PILE SEAL   JOINT BROSSSE	6H

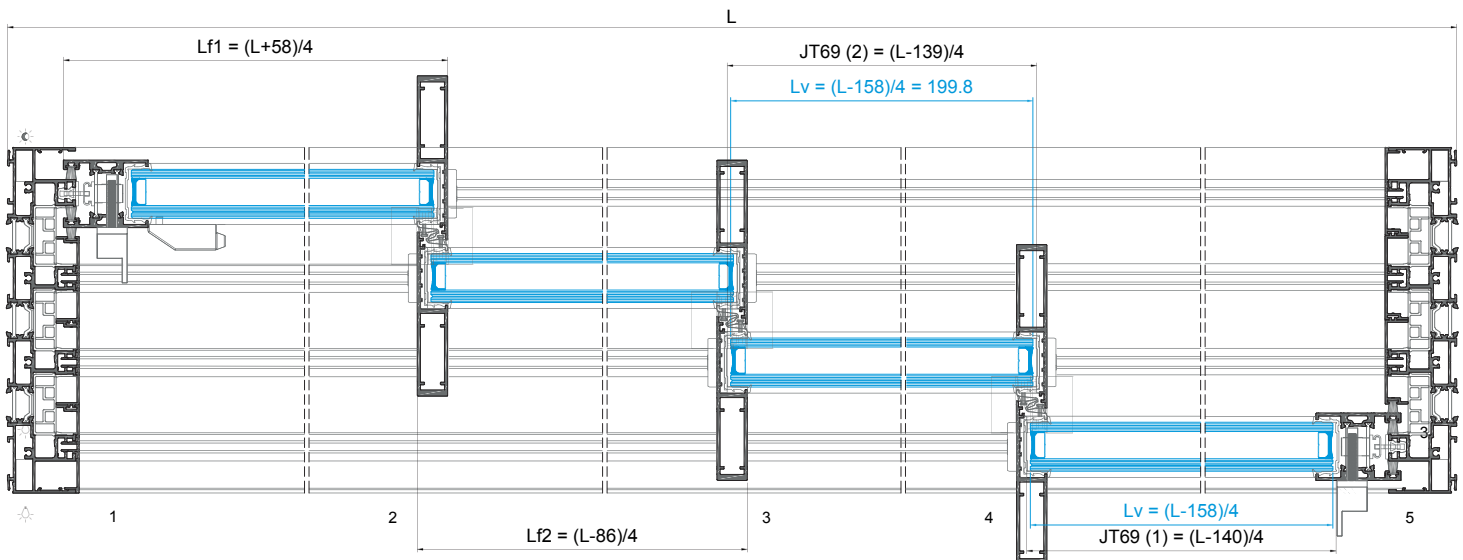



JANELA / PORTA DE CORRER 2 FOLHAS - SOLEIRA 30MM 2RAIL E OMBREIRA JT 18

2 SASHES SLIDING WINDOW / DOOR - 2RAIL 30MM SILL AND JT18 JAMB

FENÊTRE / PORTE-FENÊTRE COULISSANT 2 VANTAUX - SEUIL 30MM ET JAMBAGE JT18

PERFIS   PROFILES   PROFILÉS					
CÓDIGO CODE   CODE	DESIGNAÇÃO DESIGNATION   NOMINATION	CORTE HORIZ. HORIZONTAL CUT COUPE HORIZ.	CORTE VERT. VERTICAL CUT COUPE VERTICALE	QUANT. QUANTITY QUANTITE	CORTE CUT COUPE
JT 12	PADEIRA LINTEL   LINTEAU	L-38	-	1	
JT 18	OMBREIRA JAMB   JAMBAGE	-	H	2	
JT 78	GUIA DA OMBREIRA JAMB GUIDE   GUIDE POUR JAMBAGE	-	H-76	2	
JT 22	SOLEIRA SILL   SEUIL	L-38	-	1	
JT 56	PERFIL CENTRAL CENTRAL PROFILE   PROFILÉ CENTRAL	-	H-59	2	
JT 60	PERFIL LATERAL LATERAL PROFILE   PROFILÉ LATÉRAL	-	H-59	2	
JT 69	TRAVESSA SUP/INF UP/LW TRANSOM   TRAVERSE SUP/INF	(L-126)/2	-	4	
JT 82	PERFIL PINGADEIRA DRIP PROFILE   L'ARMIER	L-4	-	1	
JT 87	GUIA GUIDE   GUIDE	L-51	-	2	
JE 96	PERFIL POLIAMIDA POLYAMIDE PROFILE   PROFILÉ DE POLYAMIDE	(L-90)/2	H	2 + 2	
208351	JUNTA CENTRAL 2197 CENTRAL JOINT   JOINT CENTRALE	-	H-59	2	
215305	PERFIL PVC U U PVC PROFILE   PROFILÉ PVC U	L-38	-	1	

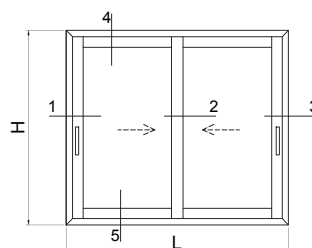

ACESSÓRIOS   ACCESSORIES   ACCESSOIRES		
CÓDIGO CODE   CODE	DESIGNAÇÃO DESIGNATION   NOMINATION	QUANT. QUANTITY QUANTITE
205000	CARRINHO JT-SLIM ROLLER   ROULETTE	4
213402	CORTA-VENTO JT-SLIM CENTRAL WATERPROOFING BRUSH   BRUSSE CENTRALE D'ÉTANCHÉITÉ	1
213288	CORTA-VENTO BAIXO JT LOW CENTRAL WATERPROOFING BRUSH   BRUSSE CENTRALE D'ÉTANCHÉITÉ BAS	1
223105	KIT JUNTAS ADESIVAS Nº1 JT JT Nº1 ADHESIVE JOINTS KIT   KIT DE JOINTS ADHÉSIFS Nº1 JT	1
212131	CONJ. TOPOS LATERAL JT-SLIM LATERAL END-CAPS KIT   KIT D'EMBOUTS LATÉRAUX	2
212133	CONJ. TOPOS CENTRAL JT-SLIM CENTRAL END-CAPS KIT   KIT D'EMBOUTS CENTRAUX	2
210231	TOPO CENTRAL REFORÇADO JT56 28MM 28MM CENTRAL REINFORCED END-CAPS KIT   KIT D'EMBOUTS CENTRAUX RENFORCÉ 28MM	4
210268	GOTEIRA C/ VALV. SVE OUTSIDE FLAP VALVE   CLAPE À VOLET EXTÉRIEUR	(a)
211234	MULTIPONTO ALU MAC. 1000 (2P) MULTIPOINT HARDWARE   SERRURE MULTIPOINT	2
202330	CONTRA-FECHO ALU STRIKING PLATE   GÂCHE	4
212455	CONJ. FIX. CONTRA-FECHO AL MULTIP. JT MULTIPOINT HARDWARE STRIKING PLATE FIXING KIT   KIT FIXATION GÂCHE SERRURE MULTIPOINT	4
212289	CONJ. CENTRADOR P/ FERRAGEM ALU CENTERING KIT FOR ALU HARDWARE   KIT CENTRAGE POUR SERRURE ALU	2
212373	CONJ. FIXAÇÃO JT-SLIM FIXING KIT   KIT FIXATION	12
200819	PUXADOR SLIM XS - ESQUERDO LEFT HANDLE   POIGNÉE GAUCHE	1
200817	PUXADOR SLIM XS - DIREITO RIGHT HANDLE   POIGNÉE DROITE	1
212384	CONJ. TOPOS LAT. PINGADEIRA JT82 LATERAL DRIP END-CAPS KIT   KIT D'EMBOUTS LATÉRAUX POUR REJET D'EAU	1
228107	LIMITADOR ABERT. PQ SERIE CORRER OPENING LIMITER   LIMITEUR D'OUVERTURE	1
290052	PARAF. DIN7982 PH 3,5x16 A2 SCREW   VIS	1 + 4 un./m
290087	PARAF. DIN7981 PH 4,8x63 INOX A2 SCREW   VIS	4
290091	PARAFUSO DIN7981 PH 4,8x50 A2 SCREW   VIS	4
290030	PARAFUSO DIN7981 PH 4,2x38 INOX A2 SCREW   VIS	8
290465	PARAF. M5x30 (PARA PUXADOR SLIM XS) SCREW   VIS	4
290051	PARAFUSO AUTO-PERF. CX 4,2x13 A2 (PARA PUXADOR SLIM XS) SCREW   VIS	4
218147	CALÇO REFORÇO HORIZONTAL JT-SLIM * HORIZONTAL REINFORCEMENT SHIM   CALE DE RENFORCEMENT HORIZONTALE	4

\* Usar em folhas com vidros com peso superior a 80kg  
To be used in sashes which glass weight exceed 80kg | Utiliser dans des panneaux de verre d'un poids supérieur à 80 kg

(a) Conforme esquemas de drenagem (Capítulo V - Maquinações)  
According to drainage schemes (Chapter V - Machinings) | Selon les schémas de drainage (Chapitre V - Usinages)

VEDANTES   SEALS   JOINTS		
CÓDIGO CODE   CODE	DESIGNAÇÃO DESIGNATION   NOMINATION	QUANT. QUANTITY QUANTITE
208348	JUNTA TAPA CANAL 2116 JT JOINT   JOINT	2L + 2H
208099	JUNTA VIDRO U 1032 CX 32MM JT GLAZING GASKET   JOINT VITREUX	2L + 4H
208307	PELÚCIA 7x10 TRI-FIN PRETA PILE SEAL   JOINT BRUSSE	4L + 4H
208469	PELÚCIA SRF 4X8 2P1M Preta PILE SEAL   JOINT BRUSSE	2H

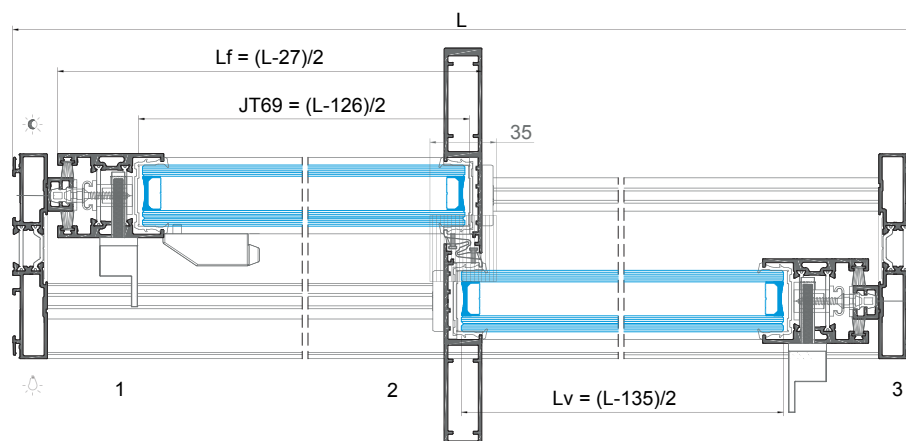
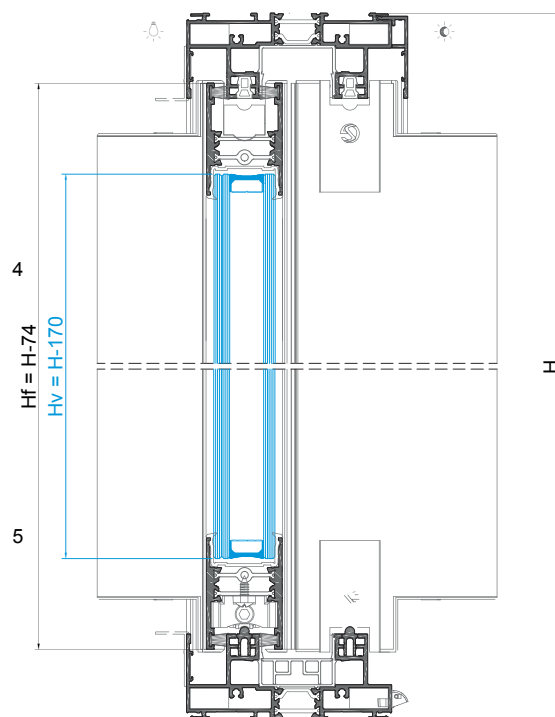

**JANELA DE CORRER 4 FOLHAS 2-RAIL COM OMBREIRA JT18 COM LIGAÇÃO CENTRAL - LINHA SOLEIRA 30MM**  
4 SASHES 2-RAIL AND JT18 JAMB SLIDING WINDOW WITH CENTRAL CONNECTION - 30MM SILL LINE  
FENÊTRE COULISSANT 4 VANTAUX 2-RAIL AVEC JAMBAGE JT18 AVEC CONNEXION CENTRALE - LIGNE SEUIL 30MM

PERFIS   PROFILES   PROFILÉS					
CÓDIGO CODE   CODE	DESIGNAÇÃO DESIGNATION   NOMINATION	CORTE HORIZ. HORIZONTAL CUT COUPE HORIZ.	CORTE VERT. VERTICAL CUT COUPE VERTICALE	QUANT. QUANTITY QUANTITE	CORTE CUT COUPE
JT 12	PADEIRA JAMB   LINTEAU	L-39	-	1	
JT 18	OMBREIRA JAMB   JAMBAGE	-	H	2	
JT 78	GUIA DA OMBREIRA JAMB GUIDE   GUIDE POUR JAMBAGE	-	H-74	2	
JT 22	SOLEIRA SILL   SEUIL	L-39	-	1	
JT 56	PERFIL CENTRAL CENTRAL PROFILE   PROFILÉ CENTRAL	-	H-59	4	
JT 60	PERFIL LATERAL LATERAL PROFILE   PROFILÉ LATÉRAL	-	H-59	4	
JT 69	TRAVESSA SUP/INF UP/LW TRANSVERSAL KIT   TRAVERSE SUP/INF	(L-211)/4	-	8	
JT 71	PERFIL LIGAÇÃO CENTRAL CONNECTION PROFILE   PROFILÉ DE LIAISON	-	H-119	1	
JT 82	PERFIL PINGADEIRA DRIP PROFILE   L'ARMIER	L-4	-	1	
JT 87	GUIA GUIDE	L-65 L-38	-	1	
JE 96	PERFIL POLIAMIDA POLYAMIDE PROFILE   PROFILÉ DE POLYAMIDE	(L-101)/4 (L-182)/4	H	2 + 2	
208351	JUNTA CENTRAL 2197 CENTRAL JOINT   JOINT CENTRALE	-	H-59	4	
215305	PERFIL PVC U U PVC PROFILE   PROFILÉ PVC U	L-39	-	1	

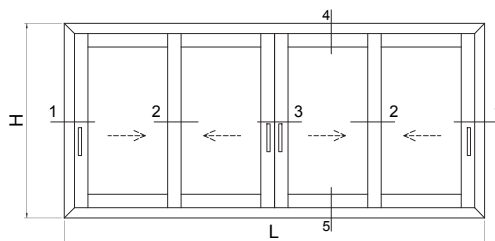

ACESSÓRIOS   ACCESSORIES   ACCESSOIRES			
CÓDIGO CODE   CODE	DESIGNAÇÃO DESIGNATION   NOMINATION	QUANT. QUANTITY QUANTITE	
205000	CARRINHO JT-SLIM ROLLER   ROULETTE	8	
213402	CORTA-VENTO JT-SLIM CENTRAL WATERPROOFING BRUSH   BRUSSE CENTRALE D'ÉTANCHÉITÉ	3	
213288	CORTA-VENTO BAIXO JT LOW CENTRAL WATERPROOFING BRUSH   BRUSSE CENTRALE D'ÉTANCHÉITÉ BAS	3	
223105	KIT JUNTAS ADESIVAS Nº1 JT JT Nº1 ADHESIVE JOINTS KIT   KIT DE JOINTS ADHÉSIFS Nº1 JT	1	
212131	CONJ. TOPOS LATERAL JT-SLIM LATERAL END-CAPS KIT   KIT D'EMBOUTS LATÉRAUX	4	
212133	CONJ. TOPOS CENTRAL JT-SLIM CENTRAL END-CAPS KIT   KIT D'EMBOUTS CENTRAUX	4	
210243	TOPO CENTRAL REFORÇADO JT56 28MM 28MM CENTRAL REINFORCED END-CAPS KIT   KIT D'EMBOUTS CENTRAUX RENFORCÉ 28MM	8	
212135	CONJ. TOPOS LIG. 2 FOLHAS JT-SLIM 2 SASHES CONNECTING END-CAPS KIT   KIT D'EMBOUTS CONNEXION 2 VENTAUX	1	
210268	GOTEIRA C/ VALV. SVE OUTSIDE FLAP VALVE   CLAPE À VOLET EXTERIEUR	(a)	
211234	MULTIPONTO ALU MAC.1000 (2P) MULTIPOINT HARDWARE   SERRURE MULTIPONT	3	
202330	CONTRA-FECHO ALU STRIKING PLATE   GÂCHE	4	
212455	CONJ. FIX. CONTRA-FECHO AL MULTIP. JT MULTIPOINT HARDWARE STRIKING PLATE FIXING KIT   KIT FIXATION GÂCHE SERRURE MULTIPONT	4	
202331	CONTRA-FECHO Nº2 2F/90º ALU STRIKING PLATE   GÂCHE	2	
212458	CONJ. FIX. CONTRA-FECHO MULTIP. 2F/90º JT MULTIPOINT HARDWARE STRIKING PLATE FIXING KIT   KIT FIXATION GÂCHE SERRURE MULTIP.	2	
212289	CONJ. CENTRADOR P/ FERRAGEM ALU CENTERING KIT FOR ALU HARDWARE   KIT CENTRAGE POUR SERRURE ALU	2	
212291	CONJ. CENTRADOR P/ FERRAGEM ALU PERFIL LIG. CENTERING KIT FOR ALU HARDWARE   KIT CENTRAGE POUR SERRURE ALU	1	
212373	CONJ. FIXAÇÃO JT-SLIM FIXING KIT   KIT FIXATION	18	
212017	CONJ. FIX. FERRAGEM MULTIP. MULTIPOINT HARDWARE FIXING KIT   KIT FIXATION POUR SERRURE MULTIPONT	1 + 1 un./m (min. 4)	
200819	PUXADOR SLIM XS - ESQUERDO LEFT HANDLE   POIGNÉE GAUCHE	1	
200817	PUXADOR SLIM XS - DIREITO RIGHT HANDLE   POIGNÉE DROITE	2	
200057	PUXADOR FOLHA PASSIVA SLIM XS PASSIVE SASH HANDLE   POIGNÉE VENTAIL PASSIVE	1	
212384	CONJ. TOPOS LAT. PINGADEIRA JT82 LATERAL DRIP END-CAPS KIT   KIT D'EMBOUTS LATÉRAUX POUR REJET D'EAU	1	
228107	LIMITADOR ABERT. PQ SERIE CORRER OPENING LIMITER   LIMITEUR D'OUVRETURE	2	
290052	PARAF. DIN7982 PH 3,5x16 A2 SCREW   VIS	1 + 4 un./m	
290087	PARAF. DIN7981 PH 4,8x63 INOX A2 SCREW   VIS	8	
290091	PARAFUSO DIN7981 PH 4,8x50 A2 SCREW   VIS	8	
290030	PARAFUSO DIN7981 4,2x38 INOX A2 SCREW   VIS	8	
290465	PARAF. M5x30 (PARA PUXADOR SLIM XS) SCREW   VIS	6	
290051	PARAFUSO AUTO-PERF. CX 4,2X13 A2 (PARA PUXADOR SLIM XS) SCREW   VIS	6	
218147	CALÇO REFORÇO HORIZONTAL JT-SLIM * HORIZONTAL REINFORCEMENT SHIM   CALE DE RENFORCEMENT HORIZONTALE	8	

\* Usar em folhas com vidros com peso superior a 80kg  
To be used in sashes which glass weight exceed 80kg | Utiliser dans des panneaux de verre d'un poids supérieur à 80 kg  
(a) Conforme esquemas de drenagem (Capítulo V - Maquiagens)  
According to drainage schemes (Chapter V - Machinings) | Selon les schémas de drainage (Chapitre V - Usinages)

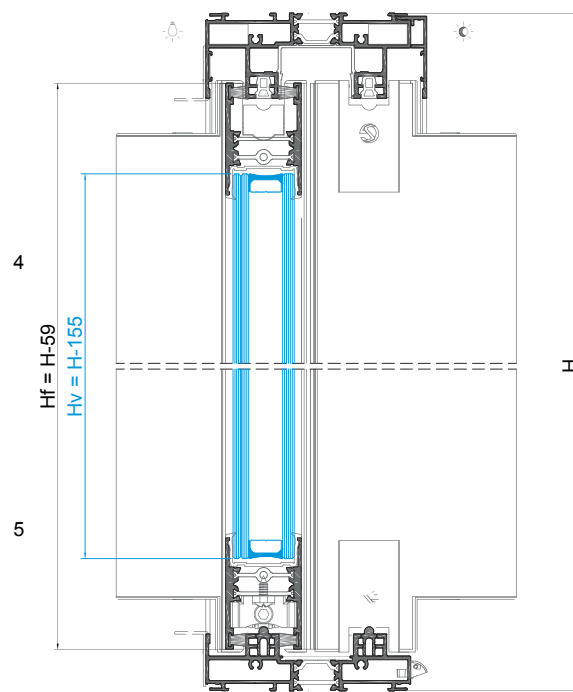

VEDANTES   SEALS   JOINTS		
CÓDIGO CODE   CODE	DESIGNAÇÃO DESIGNATION   NOMINATION	QUANT. QUANTITY QUANTITE
208348	JUNTA TAPA CANAL 2116 JT JOINT   JOINT	2L + 2H
208099	JUNTA VIDRO U 1032 CX 32MM JT GLAZING GASKET   JOINT DE IVTRAGE	2L + 8H
208307	PELUCIA 7x10 TRI-FIN PRETA PILE SEAL   JOINT BRUSSE	4L + 10H
208479	JUNTA TAPA CANAL PERFIL LIG. 2117 JT JOINT   JOINT	H
208469	PELÚCIA SRF 4X8 2P1M Preta PILE SEAL   JOINT BRUSSE	2H

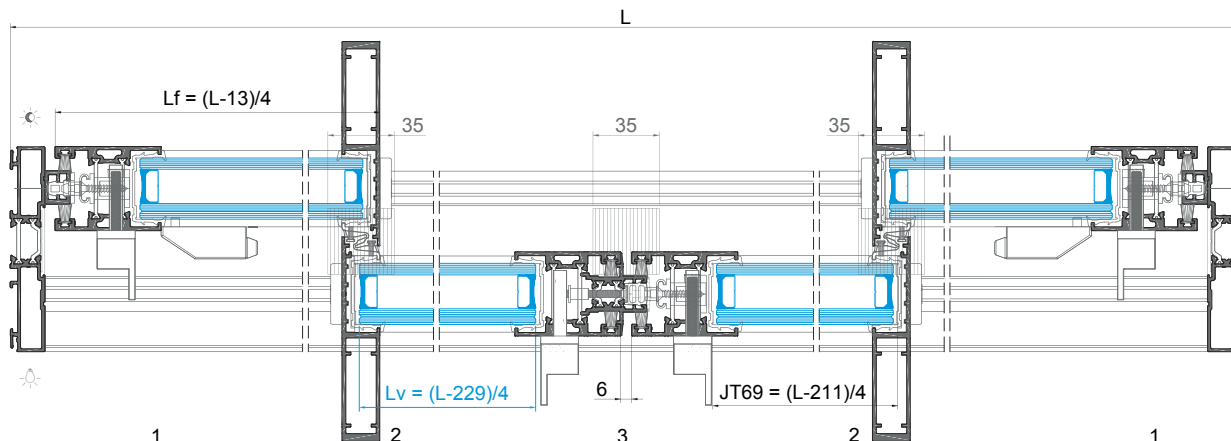

**JANELA DE CORRER 4 FOLHAS 2-RAIL CANTO 90° COM OMBREIRA JT18 - LINHA SOLEIRA 30MM**  
4 SASHES 2-RAIL WITH JT18 JAMB SLIDING WINDOW 90° CORNER - 30MM SILL LINE  
FENÊTRE COULISSANT 4 VANTAUX AVEC JAMBAGE JT18 À ANGLE 90° - LIGNE SEUIL 30MM

PERFIS   PROFILES   PROFILÉS					
CÓDIGO CODE   CODE	DESIGNAÇÃO DESIGNATION   NOMINATION	CORTE HORIZ. HORIZONTAL CUT COUPE HORIZ.	CORTE VERT. VERTICAL CUT COUPE VERTICALE	QUANT. QUANTITY QUANTITE	CORTE CUT COUPE
JT 12	PADEIRA LINTEL   LINTEAU	L1-19 L2-19	-	1	
JT 18	OMBREIRA JAMB   JAMBAGE	-	H-74	2	
JT 78	GUIA DA OMBREIRA JAMB GUIDE   GUIDE POUR JAMBAGE	-	H-74	2	
JT 22	SOLEIRA SILL   SEUIL	L1-19 L2-19	-	1	
JT 56	PERFIL CENTRAL CENTRAL PROFILE   PROFILÉ CENTRAL	-	H-59	4	
JT 60	PERFIL LATERAL LATERAL PROFILE   PROFILÉ LATÉRAL	-	H-59	2	
JT 70	PERFIL LIGAÇÃO CANTO 90° CORNER PROFILE   PROFILÉ DE LIAISON	-	H-59	2	
JT 69	TRAVESSA SUP/INF UP/LOW TRANSOM   TRAVERSE SUP/INF	(L1-197)/2 (L2-209)/2	-	4	
JT 72	PERFIL LIGAÇÃO CENTRAL CONNECTION PROFILE   PROFILÉ DE LIAISON	-	H-119	1	
JT 82	PERFIL PINGADEIRA DRIP PROFILE   L'ARMIER	L1+6 L2+6	-	1	
JT 87	GUIA GUIDE   GUIDE	L1-50 L1-93 L2-50 L2-93	-	1	
JE 96	PERFIL POLIAMIDA POLYAMIDE PROFILE   PROFILÉ DE POLYAMIDE	(L1-142)/2 (L1-170)/2 (L2-155)/2	H	1	
208351	JUNTA CENTRAL 2197 CENTRAL JOINT   JOINT CENTRALE	-	H-59	4	
215305	PERFIL PVC U U PVC PROFILE   PROFILÉ PVC U	L1-19 L2-19	-	1	

VEDANTES   SEALS   JOINTS		
CÓDIGO CODE   CODE	DESIGNAÇÃO DESIGNATION   NOMINATION	QUANT. QUANTITY QUANTITE
208348	JUNTA TAPA CANAL 2116 JT JOINT   JOINT	2L1 2L2 + 2H
208099	JUNTA VIDRO U 1032 CX 32MM JT GLAZING GASKET   JOINT DE IVTRAGE	2L1 + 8H 2L2
208307	PELÚCIA 7x10 TRI-FIN PRETA FILE SEAL   JOINT BRUSSE	4L1+11H 4L2
208479	JUNTA TAPA CANAL PERFIL LIG. 2117 JT JOINT   JOINT	H
208435	JUNTA VD 2415 JOINT   JOINT	H
208469	PELÚCIA SRF 4X8 2P1M Preta PILE SEAL   JOINT BRUSSE	2H

ACESSÓRIOS   ACCESSORIES   ACCESSOIRES		
CÓDIGO CODE   CODE	DESIGNAÇÃO DESIGNATION   NOMINATION	QUANT. QUANTITY QUANTITE
205000	CARRINHO JT-SLIM ROLLER   ROULETTE	8
213402	CORTA-VENTO JT-SLIM CENTRAL WATERPROOFING BRUSH   BRUSSE CENTRALE D'TANCHÉITÉ	2
213288	CORTA-VENTO BAIXO JT LOW CENTRAL WATERPROOFING BRUSH   BRUSSE CENTRALE D'TANCHÉITÉ BAS	5
213287	CORTA-VENTO CANTO 90° JT 90° CORNER WATERPROOFING BRUSH   BRUSSE D'TANCHÉITÉ ANGLE 90°	1
223105	KIT JUNTAS ADESIVAS Nº1 JT KIT ADHESIVE JOINTS KIT   KIT DE JOINTS ADHÉSIFS Nº1 JT	1
212243	CONJ. UNIÃO CANTO 90° JT 90° CORNER UNION KIT   KIT D'UNION ANGLE 90°	1
212084	CONJ. UNIÃO CANTO 90° ARO BAIXO JT 90° CORNER LOW FRAME UNION KIT   KIT D'UNION ANGLE 90° POUR CADRE BAS	1
204389	ESQUADRO INOX CANTO 90° 90° STAINLESS STEEL CORNER   ANGLE EN ACIER INOXYDABLE 90°	1
212131	CONJ. TOPOS LATERAL JT-SLIM LATERAL END-CAPS KIT   KIT D'EMBOÛTS LATÉRAUX	4
212133	CONJ. TOPOS CENTRAL JT-SLIM CENTRAL END-CAPS KIT   KIT D'EMBOÛTS CENTRAUX	4
210231	TOPO CENTRAL REFORÇADO JT56 28MM 28MM CENTRAL REINFORCED END-CAPS KIT   KIT D'EMBOÛTS CENTRAUX RENFORCÉ 28MM	8
212151	CONJ. TOPOS CANTO 90° JT-SLIM 90° CORNER END-CAPS KIT   KIT D'EMBOÛTS POUR ANGLE 90°	1
210268	GOTEIRA C/ VALV. SVE OUTSIDE FLAP VALVE   CLAPE À VOLET EXTÉRIEUR	(a)
211234	MULTIPONTO ALU MAC.1000 (2P) MULTIPOINT HARDWARE   SERRURE MULTIPONT	3
202330	CONTRA-FECHO ALU STRIKING PLATE   GÂCHE	4
212455	CONJ. FIX. CONTRA-FECHO AL MULTIP. JT MULTIPOINT HARDWARE STRIKING PLATE FIXING KIT   KIT FIXATION GÂCHE SERRURE MULTIPONT	4
202331	CONTRA-FECHO Nº2 2F/90° ALU STRIKING PLATE   GÂCHE	2
212458	CONJ. FIX. CONTRA-FECHO MULTIP. 2F/90° JT MULTIPOINT HARDWARE STRIKING PLATE FIXING KIT   KIT FIXATION GÂCHE SERRURE MULTIP.	2
212289	CONJ. CENTRADOR P/ FERRAGEM ALU CENTERING KIT FOR ALU HARDWARE   KIT CENTRAGE POUR SERRURE ALU	2
212291	CONJ. CENTRADOR P/ FERRAGEM ALU PERFIL LIG. CENTERING KIT FOR ALU HARDWARE   KIT CENTRAGE POUR SERRURE ALU	1
212373	CONJ. FIXAÇÃO JT-SLIM FIXING KIT   KIT FIXATION	18
212079	CONJ. FIX. FERRAGEM MULTIP. JT72 MULTIPOINT FIXING KIT   KIT FIXATION SERRURE MULTIPONT	1 + 1 un./m (min. 4)
200819	PUXADOR SLIM XS - ESQUERDO LEFT HANDLE   POIGNÉE GAUCHE	1
200817	PUXADOR SLIM XS - DIREITO RIGHT HANDLE   POIGNÉE DROITE	2
212384	CONJ. TOPOS LAT. PINGADEIRA JT82 LATERAL DRIP END-CAPS KIT   KIT D'EMBOÛTS LATÉRAUX POUR REJET D'EAU	1
228107	LIMITADOR ABERT. PQ SERIE CORRER OPENING LIMITER   LIMITEUR D'OUVERTURE	2
290052	PARAF. DIN7982 PH 3,5x16 A2 SCREW   VIS	1 + 4 un./m
290087	PARAF. DIN7981 PH 4,8x63 INOX A2 SCREW   VIS	8
290091	PARAFUSO DIN7981 PH 4,8x50 A2 SCREW   VIS	8
290030	PARAFUSO DIN7981 4,2x38 INOX A2 SCREW   VIS	8
290465	PARAF. M5x30 (PARA PUXADOR SLIM XS) SCREW   VIS	6
290051	PARAFUSO AUTO-PERF. CX 4,2X13 A2 (PARA PUXADOR SLIM XS) SCREW   VIS	6
218147	CALÇO REFORÇO HORIZONTAL JT-SLIM * HORIZONTAL REINFORCEMENT SHIM   CALE DE RENFORCEMENT HORIZONTALE	8

\* Usar em folhas com vidros com peso superior a 80kg  
To be used in sashes with glass weight exceed 80kg | Utiliser dans des panneaux de verre d'un poids supérieur à 80 kg  
(a) Conforme esquemas de drenagem (Capítulo V - Maquinações)  
According to drainage schemes (Chapter V - Machinings) | Selon les schémas de drainage (Chapitre V - Usinages)

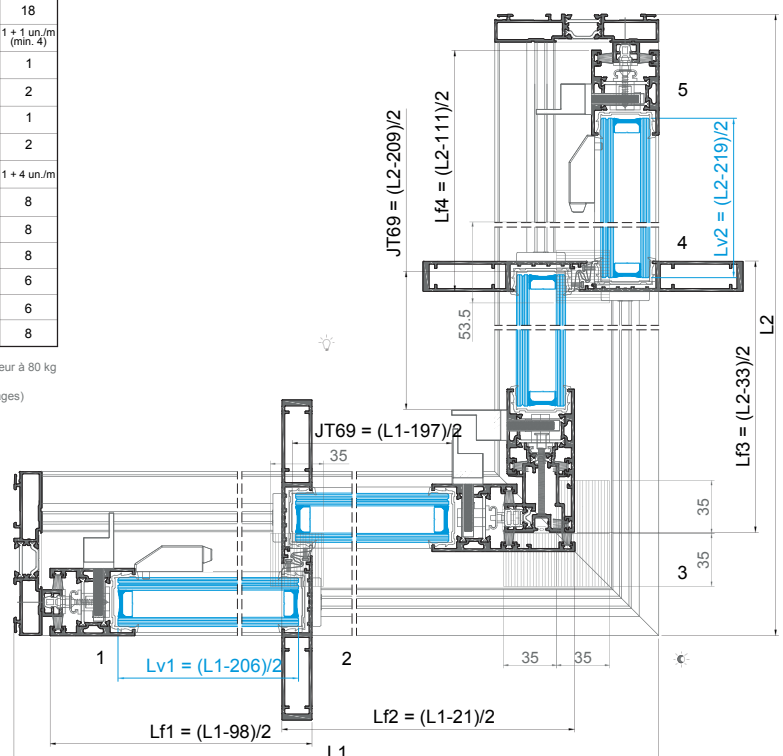
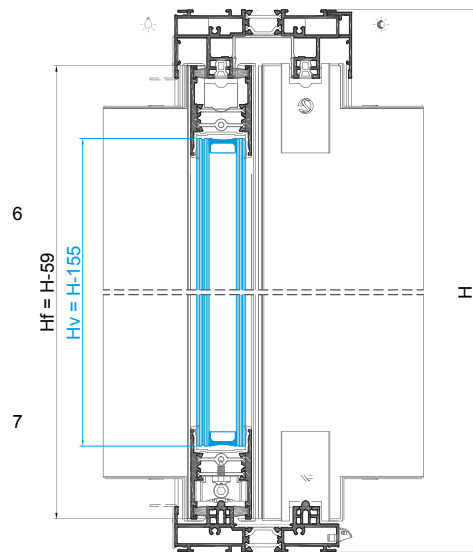

## JANELA DE CORRER 2 FOLHAS JT 2-RAIL COM PERFIS CENTRAIS 20mm - LINHA FR

2 JT SASHES 2-RAIL SLIDING WINDOW WITH 20mm CENTRAL PROFILES - FR LINE

FENÊTRE COULISSANT 2 VANTAUX JT 2-RAIL AVEC PROFILÉS CENTRAUX 20mm - LIGNE FR

PERFIS   PROFILES   PROFILÉS					
CÓDIGO CODE   CODE	DESIGNAÇÃO DESIGNATION   NOMINATION	CORTE HORIZ. HORIZONTAL CUT COUPE HORIZ.	CORTE VERT. VERTICAL CUT COUPE VERTICALE	QUANT. QUANTITY QUANTITE	CORTE CUT COUPE
JT 02	ARO FIXO FIXED FRAME   CADRE DORMANT	L	H	2 + 2	
JT 56	PERFIL CENTRAL CENTRAL PROFILE   PROFILÉ CENTRAL	-	H-81	2	
JT 68	PERFIL LATERAL LATERAL PROFILE   PROFILÉ LATÉRAL	-	H-81	2	
JT 63	TRAVESSA SUP/INF UP/LW TRANSOM   TRAVERSE SUP/INF	(L-189)/2	-	4	
AT 30	CAPA COVER   CAPOT	L-44	-	1	
JT 83	PERFIL PINGADEIRA DRIP PROFILE   LARMIER	L-44	-	1	
JT 85	CAPA COVER   CAPOT	-	H-58	2	
JT 87	GUIA GUIDE   GUIDE	L-100	-	2	
208351	JUNTA CENTRAL 2197 CENTRAL JOINT   JOINT CENTRALE	-	H-81	2	
215305	PERFIL PVC U U PVC PROFILE   PROFILÉ PVC U	L-41	H-41	2 + 2	
215303	PERFIL PVC T T PVC PROFILE   PROFILÉ PVC T	(L-125)/2	H-44	2 + 2	

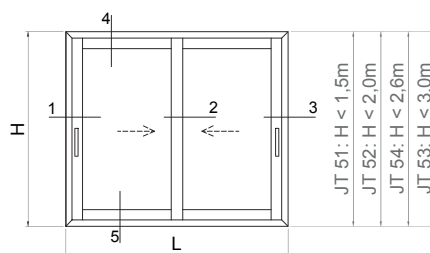

ACESSÓRIOS   ACCESSORIES   ACCESSOIRES		
CÓDIGO CODE   CODE	DESIGNAÇÃO DESIGNATION   NOMINATION	QUANT. QUANTITY QUANTITE
205129	CARRINHO JT 180KG ROLLER   ROULETTE	4
213402	CORTA-VENTO JT-SLIM CENTRAL WATERPROOFING PILE SEAL   BROSSSE CENTRALE D'ETANCHÉITÉ	2
212337	CONJ. ESTANQ. CORTA-VENTO JT CENTRAL WATERPROOFING PILE SEAL KIT   KIT BROSSSE CENTRALE D'ETANCHÉITÉ	1
204164	ESQUADRO JT 12x9,5 CORNER CLEAT   EQUERRE	8
213014	CANTO ALINHAMENTO JT ALIGNMENT CORNER   ANGLE D'ALIGNEMENT	4
213246	CANTO CR S/SB CORNER   ANGLE	4
212199	CONJ. TOPOS LAT. JT LATERAL END-CAPS KIT   KIT D'EMBOUTS LATÉRAUX	2
212230	CONJ. TOPOS INTERIOR LAT. JT LATERAL INNER END-CAPS KIT   KIT D'EMBOUTS INTÉRIEUR LATÉRAUX	2
212201	CONJ. TAMPAS TOPOS LAT. JT LATERAL END-CAP COVERS KIT   KIT DE COUVERTURE POUR EMBOUTS LATÉRAUX	2
210288	TOPO LATERAL JT68 28MM 28MM LATERAL END-CAPS KIT   KIT D'EMBOUTS LATÉRAUX JT68 28MM	4
212273	CONJ. TOPOS CENTRAIS N 1 20MM JT N1 20MM JT CENTRAL END-CAPS KIT   KIT D'EMBOUTS CENTRAUX N1 20MM JT	2
212252	CONJ. TOPOS INTERIORES LAT./CENTR. JT-SLIM LAT./CENTR INNER END-CAP COVERS KIT   KIT DE COUVERT. POUR EMBOUTS LAT/CENTR INTÉR.	2
212335	CONJ. TAMPAS TOPOS CENTRAIS JT CENTRAL END-CAP COVERS KIT   KIT DE COUVERTURE POUR EMBOUTS CENTRAUX	2
210231	TOPO CENTRAL REFORÇADO JT56 28MM 28MM CENTRAL REINFORCED END-CAPS KIT   KIT D'EMBOUTS CENTRAUX RENFORCÉ 28MM	4
210269	GOTEIRA OCULTA C/ VALV. SV-C13 FLAP VALVE   CLAPE À VOLET CACHÉ	(a)
211223	FERRAGEM MULTIPONTO CENTR. 1000 MULTIPOINT HARDWARE   SERRURE MULTIPOINT	2
202491	CONTRA-FECHO ANTI-LEVANTAMENTO MULTIPONTO STRIKING PLATE   GÂCHE	4
202487	CENTRADOR JT P/ C-FECHO AL MULTIPONTO JT CENTERING FOR STRIKING PLATE   CENTRAGE JT POUR GÂCHE	4
212455	CONJ. FIX. CONTRA-FECHO AL MULTIP. JT MULTIPOINT HARDWARE STRIKING PLATE FIXING KIT   KIT FIXATION GÂCHE SERRURE MULTIPOINT	4
218149	CALÇO Nº2 P/ MULTIPONTO SOS JT MULTIPOINT HARDWARE SHIM   CALE POUR MULTIPOINT	12
212161	CONJ. CENTRADOR P/ FERRAGEM JT CENTERING KIT FOR JT HARDWARE   KIT CENTRAGE POUR SERRURE JT	2
212371	CONJ. FIXAÇÃO JT FIXING KIT   KIT FIXATION	12
200819	PUXADOR SLIM XS - ESQUERDO LEFT HANDLE   POIGNÉE GAUCHE	1
200817	PUXADOR SLIM XS - DIREITO RIGHT HANDLE   POIGNÉE DROITE	1
212341	CONJ. TOPOS LAT. PINGADEIRA LATERAL DRIP END-CAPS KIT   KIT D'EMBOUTS LATÉRAUX POUR REJET D'EAU	1
228107	LIMITADOR ABERT. PQ SERIE CORRER OPENING LIMITER   LIMITÉUR D'OUVERTURE	1
290472	PARAF. AT/PF CQ Ø3.9x19MM SCREW   VIS	1 + 1 un./m
290262	PARAFUSO PK INOX PH 1 1/2X10 CQ SCREW   VIS	16
218137	CALÇO REFORÇO HORIZONTAL JT * HORIZONTAL REINFORCEMENT SHIM   CALE DE RENFORCEMENT HORIZONTALE	4

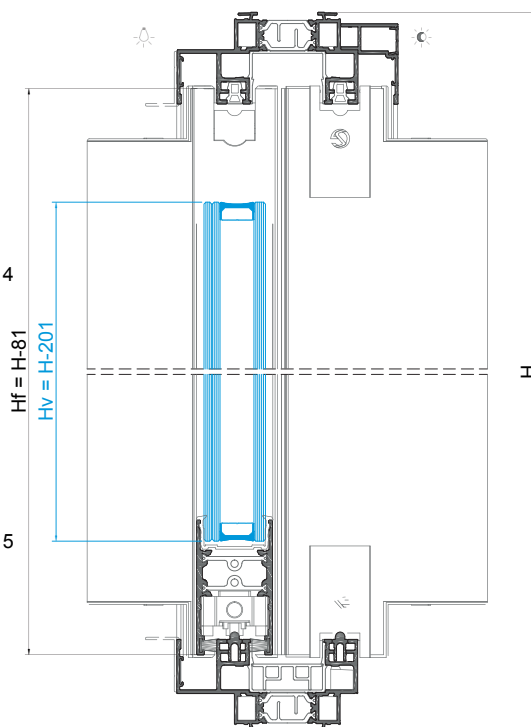

VEDANTES   SEALS   JOINTS		
CÓDIGO CODE   CODE	DESIGNAÇÃO DESIGNATION   NOMINATION	QUANT. QUANTITY QUANTITE
208348	JUNTA TAPA CANAL 2116 JT JOINT   JOINT	2L + 2H
208099	JUNTA VIDRO U 1032 CX 32MM JT GLAZING GASKET   JOINT DE VITRAGE	2L + 4H
208307	PELUCIA 7x10 TRI-FIN PRETA PILE SEAL   JOINT BROSSSE	4L + 6H
208469	PELUCIA SRF 4X8 2P1M Preta PILE SEAL   JOINT BROSSSE	2H

\* Usar em folhas com vidros com peso superior a 80kg  
To be used in sashes with glass weight exceed 80kg | Utiliser dans des panneaux de verre d'un poids supérieur à 80 kg

(a) Conforme esquemas de drenagem (Capítulo V - Maquinações)  
According to drainage schemes (Chapter V - Machinings) | Selon les schémas de drainage (Chapitre V - Usinages)

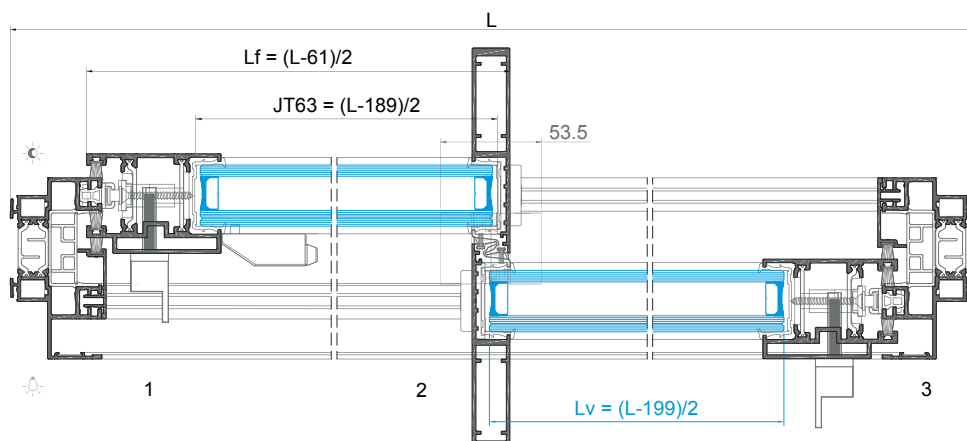

## JANELA DE CORRER 2 FOLHAS JT 2-RAIL COM PERFIS CENTRAIS 20mm - LINHA FR

### 2 JT SASHES 2-RAIL SLIDING WINDOW WITH 20mm CENTRAL PROFILES - FR LINE

### FENÊTRE COULISSANT 2 VANTAUX JT 2-RAIL AVEC PROFILÉS CENTRAUX 20mm - LIGNE FR

PERFIS   PROFILES   PROFILÉS					
CÓDIGO CODE   CODE	DESIGNAÇÃO DESIGNATION   NOMINATION	CORTE HORIZ. HORIZONTAL CUT COUPE HORIZ.	CORTE VERT. VERTICAL CUT COUPE VERTICALE	QUANT. QUANTITY QUANTITE	CORTE CUT COUPE
JT 02	ARO FIXO FIXED FRAME   CADRE DORMANT	L	H	2 + 2	
JT 56	PERFIL CENTRAL CENTRAL PROFILE   PROFILÉ CENTRAL	-	H-81	4	
JT 68	PERFIL LATERAL LATERAL PROFILE   PROFILÉ LATÉRAL	-	H-81	4	
JT 63	TRAVESSA SUP/INF UP/LW TRANSOM   TRAVERSE SUP/INF	(L-305)/4	-	8	
JT 71	PERFIL LIGAÇÃO CENTRAL CONNECTION PROFILE   PROFILÉ DE LIAISON	-	H-149	1	
AT 30	CAPA COVER   CAPOT	L-44	-	1	
JT 83	PERFIL PINGADEIRA DRIP PROFILE   LARMIER	L-44	-	1	
JT 85	CAPA COVER   CAPOT	-	H-58	2	
JT 87	GUIA GUIDE   GUIDE	L-102 L-97	-	1 1	
208351	JUNTA CENTRAL 2197 CENTRAL JOINT   JOINT CENTRALE	-	H-81	4	
215305	PERFIL PVC U U PVC PROFILE   PROFILÉ PVC U	L-41	H-41	2 + 2	
215303	PERFIL PVC T T PVC PROFILE   PROFILÉ PVC T	(L-176)/4 (L-291)/4	H-44	2 + 2	

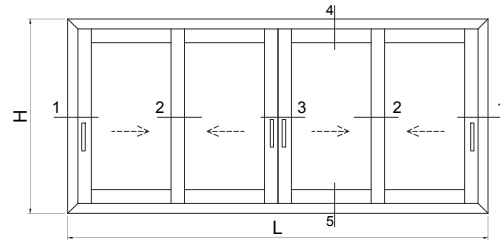

ACESSÓRIOS   ACCESSORIES   ACCESSOIRES		
CÓDIGO CODE   CODE	DESIGNAÇÃO DESIGNATION   NOMINATION	QUANT. QUANTITY QUANTITE
205129	CARRINHO JT 180KG ROLLER   ROULETTE	8
213402	CORTA-VENTO JT-SLIM CENTRAL WATERPROOFING PILE SEAL   BRUSSE CENTRALE D'ÉTANCHEITÉ	6
212337	CONJ. ESTANO. CORTA-VENTO JT CENTRAL WATERPROOFING BRUSH KIT   KIT BRUSSE CENTRALE D'ÉTANCHEITÉ	3
204164	ESQUADRO JT 12x9.5 CORNER CLEAT   ÉQUERRE	8
213014	CANTO ALINHAMENTO JT ALIGNMENT CORNER   ANGLE D'ALIGNEMENT	4
213246	CANTO CR S/SB CORNER   ANGLE	4
212199	CONJ. TOPOS LAT. JT LATERAL END-CAPS KIT   KIT D'EMBOUTS LATÉRAUX	4
212230	CONJ. TOPOS INTERIOR LAT. JT LATERAL INNER END-CAPS KIT   KIT D'EMBOUTS INTÉRIEUR LATÉRAUX	3
212201	CONJ. TAMPAS TOPOS LAT. JT LATERAL END-CAP COVERS KIT   KIT DE COUVERTURE POUR EMBOUTS LATÉRAUX	3
210288	TOPO LATERAL JT68 28MM 28MM JT68 LATERAL END-CAPS KIT   KIT D'EMBOUTS LATÉRAUX JT68 28MM	8
212273	CONJ. TOPOS CENTRAIS N.1 20MM JT N1 20MM JT CENTRAL END-CAPS KIT   KIT D'EMBOUTS CENTRAUX N.1 20MM JT	4
212252	CONJ. TOPOS INTERIORES LAT./CENTR. JT-SLIM LAT/CENT INNER END-CAP COVERS KIT   KIT DE COUVERT. POUR EMBOUTS LAT/CENTR INTÉR.	4
212335	CONJ. TAMPAS TOPOS CENTRAIS JT-SLIM CENTRAL END-CAP COVERS KIT   KIT DE COUVERTURE POUR EMBOUTS CENTRAUX	4
210231	TOPO CENTRAL REFORÇADO JT56 28MM 28MM CENTRAL REINFORCED END-CAPS KIT   KIT D'EMBOUTS CENTRAUX RENFORCÉ 28MM	8
212104	CONJ. TOPOS LIG. 2 FOLHAS JT 2 SASHES CONNECTING END-CAPS KIT   KIT D'EMBOUTS CONNEXION 2 VANTAUX	1
210269	GOTEIRA OCULTA C/ VALV. SV-C13 FLAP VALVE   CLAPE À VOILE GÂCHE	(a)
211223	FERRAGEM MULTIPONTO CENTR. 1000 MULTIPOINT HARDWARE   SERRURE MULTIPOINT	3
202491	CONTRA-FECHO ANTI-LEVANTAMENTO MULTIPONTO STRIKING PLATE   GÂCHE	6
202487	CENTRADOR JT P/ C-FECHO AL MULTIPONTO JT CENTERING FOR STRIKING PLATE   CENTRAGE JT POUR GÂCHE	4
212455	CONJ. FIX. CONTRA-FECHO AL MULTIP. MULTIPOINT HARDWARE STRIKING PLATE FIXING KIT   KIT FIXATION GÂCHE SERRURE MULTIPOINT	4
212458	CONJ. FIX. CONTRA-FECHO MULTIP. 2F/90° JT MULTIPOINT HARDWARE STRIKING PLATE FIXING KIT   KIT FIXATION GÂCHE SERRURE MULTIP.	2
218149	CALÇO Nº2 P/ MULTIPONTO SOS JT MULTIPOINT HARDWARE SHIM   CALE POUR MULTIPONTO	18
218154	CALÇO P/ C-FECHO PERF. LIG CONNECTING PROFILE STRIKING PLATE SHIM   CALE POUR GÂCHE PROFILÉ DE LIAISON	2
212161	CONJ. CENTRADOR P/ FERRAGEM JT CENTERING KIT FOR JT HARDWARE   KIT CENTRAGE POUR SERRURE JT	2
212162	CONJ. CENTRADOR P/ FERRAGEM JT PERFIL LIG. CENTERING KIT FOR JT HARDWARE   KIT CENTRAGE POUR SERRURE JT	1
212371	CONJ. FIXAÇÃO JT FIXING KIT   KIT FIXATION	18
212017	CONJ. FIX. FERRAGEM MULTIP. MULTIPOINT HARDWARE FIXING KIT   KIT FIXATION POUR SERRURE MULTIPOINT	1 + 1 un./m (min. 4)
200819	PUXADOR SLIM XS - ESQUERDO LEFT HANDLE   POIGNÉE GAUCHE	1
200817	PUXADOR SLIM XS - DIREITO RIGHT HANDLE   POIGNÉE DROITE	2
200057	PUXADOR FOLHA PASSIVA SLIM XS PASSIVE SASH HANDLE   POIGNÉE VENTAIL PASSIVE	1
212341	CONJ. TOPOS LAT. PINGADEIRA LATERAL DRIP END-CAPS KIT   KIT D'EMBOUTS LATÉRAUX POUR REJET D'EAU	1
228107	LIMITADOR ABERT. PQ SERIE CORRER OPENING LIMITER   LIMITEUR D'OUVREMENT	2
290472	PARAF. AT/PF CQ Ø3.9x19MM SCREW   VIS	1 + 1 un./m
290262	PARAFUSO PK INOX PH 1 1/2X10 CQ SCREW   VIS	32
218137	CALÇO REFORÇO HORIZONTAL JT * HORIZONTAL REINFORCEMENT SHIM   CALE DE RENFORCEMENT HORIZONTALE	8

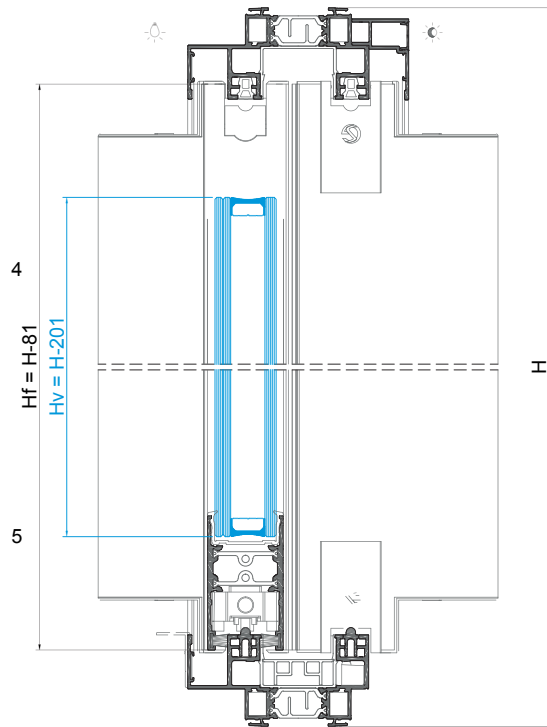

VEDANTES   SEALS   JOINTS		
CÓDIGO CODE   CODE	DESIGNAÇÃO DESIGNATION   NOMINATION	QUANT. QUANTITY QUANTITE
208348	JUNTA TAPA CANAL 2116 JT JOINT   JOINT	2L + 2H
208099	JUNTA VIDRO U 1032 CX 32MM JT GLAZING GASKET   JOINT DE VITRAGE	2L + 8H
208307	PELÚCIA 7x10 TRI-FIN PRETA PILE SEAL   JOINT BRUSSE	4L + 10H
208469	PELÚCIA SRF 4X8 2P1M Preta PILE SEAL   JOINT BRUSSE	4H
208479	JUNTA TAPA CANAL PERFIL LIG. 2117 JT JOINT   JOINT	H

\* Usar em folhas com vidros com peso superior a 80kg  
To be used in sashes with glass weight exceeding 80kg | Utiliser dans des panneaux de verre d'un poids supérieur à 80 kg

(a) Conforme esquemas de drenagem (Capítulo V - Maquiagens)  
According to drainage schemes (Chapter V - Machinings) | Selon les schémas de drainage (Chapitre V - Usinages)

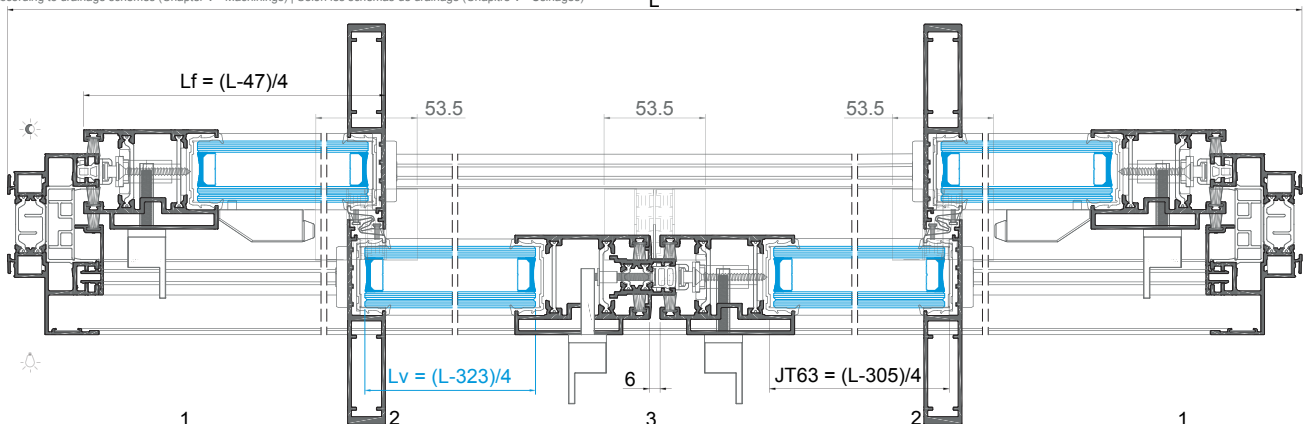



## JANELA DE CORRER 4 FOLHAS 2-RAIL CANTO 90° COM PERFIS CENTRAIS 20mm - LINHA FR

4 JT SASHES 2-RAIL SLIDING WINDOW WITH 20mm CENTRAL PROFILES IN 90° CORNER - FR LINE

FENÊTRE COULISSANT 4 VANTAUX JT 2-RAIL AVEC PROFILÉS CENTRAUX 20mm À ANGLE 90° - LIGNE FR

PERFIS   PROFILES   PROFILÉS					
CÓDIGO CODE   CODE	DESIGNAÇÃO DESIGNATION   NOMINATION	CORTE HORIZ. HORIZONTAL CUT COUPE HORIZ.	CORTE VERT. VERTICAL CUT COUPE VERTICALE	QUANT. QUANTITY QUANTITE	CORTE CUT COUPE
JT 02	ARO FIXO FIXED FRAME   CADRE DORMANT	L1 L2	H	2 2 + 2	
JT 56	PERFIL CENTRAL CENTRAL PROFILE   PROFILÉ CENTRAL	-	H-81	4	
JT 67	PERFIL LATERAL LATERAL PROFILE   PROFILÉ LATÉRAL	-	H-81	2	
JT 62	PERFIL LATERAL CANTO 90° LATERAL PROFILE 90° CORNER   PROFILÉ LATÉRAL À 90°	-	H-81	2	
JT 63	TRAVESSA SUP/INF UP/LOW TRANSOM   TRAVERSE SUP/INF	(L1-230)/2 (L2-243)/2	-	4 4	
JT 72	PERFIL LIGAÇÃO CANTO 90° CONNECTION PROFILE   PROFILÉ DE LIAISON	-	H-149	1	
AT 30	CAPA COVER   CAPOT	L1-1 L2-1	-	1 1	
JT 83	PERFIL PINGADEIRA DRIP PROFILE   LARMIER	L1-1 L2-1	-	1 1	
JT 85	CAPA COVER   CAPOT	-	H-58	2	
JT 87	GUIA GUIDE   GUIDE	L1-43 L1-112 L2-43 L2-112	-	1 1 1 1	
208351	JUNTA CENTRAL 2197 CENTRAL JOINT   JOINT CENTRALE	-	H-81	4	
215305	PERFIL PVC U U PVC PROFILE   PROFILÉ PVC U	L1-38 L2-38	H-41	2 2 + 2	
215303	PERFIL PVC T T PVC PROFILE   PROFILÉ PVC T	(L1-187)/2 (L1-230)/2 (L2-179)/2 (L2-218)/2	H-44	1 1 + 2 1 1	

VEDANTES   SEALS   JOINTS		
CÓDIGO CODE   CODE	DESIGNAÇÃO DESIGNATION   NOMINATION	QUANT. QUANTITY QUANTITE
208348	JUNTA TAPA CANAL 2116 JT JOINT   JOINT	2L1 2L2 + 2H
208099	JUNTA VIDRO U 1032 CX 32MM JT GLAZING GASKET   JOINT DE VITRAGE	2L1 + 8H 2L2
208307	PELÚCIA 7x10 TRI-FIN PRETA PILE SEAL   JOINT BRUSSE	4L1 + 11H 4L2
208469	PELÚCIA SRF 4X8 2P 1M Preta PILE SEAL   JOINT BRUSSE	4H
208479	JUNTA TAPA CANAL PERFIL LIG. 2117 JT JOINT   JOINT	H
208435	JUNTA VD 2415 JOINT   JOINT	H

As fórmulas foram concebidas para medidas de vidros iguais. Nesta tipologia existem 4 larguras de folha distintas: Lf1, Lf2, Lf3 e Lf4.  
The formulas were designed for glasses with equal measures. In this typology there are 4 distinct sash widths: Lf1, Lf2, Lf3 and Lf4.  
Les formules sont conçues pour mesurer le verre. Dans cette typologie, il existe 4 largeurs de vantaux distinctes: Lf1, Lf2, Lf3 et Lf4.

ACESSÓRIOS   ACCESSORIES   ACCESSOIRES			
CÓDIGO CODE   CODE	DESIGNAÇÃO DESIGNATION   NOMINATION	QUANT. QUANTITY QUANTITE	
205129	CARRINHO JT 180KG ROLLER   ROULETTE	8	
213402	CORTA-VENTO JT-SLIM CENTRAL WATERPROOFING BRUSH   BRUSSE CENTRALE D'ÉTANCHÉITÉ	4	
213287	CORTA-VENTO CANTO 90° JT 90° CORNER WATERPROOFING BRUSH   BRUSSE D'ÉTANCHÉITÉ ANGLE 90°	2	
212337	CONJ. ESTANQ. CORTA-VENTO JT CENTRAL WATERPROOFING BRUSH KIT   KIT BRUSSE CENTRALE D'ÉTANCHÉITÉ	4	
204164	ESQUADRO JT 12x9.5 CORNER CLEAT   ÉQUERRE	8	
213014	CANTO ALINHAMENTO JT ALIGNMENT CORNER   ANGLE D'ALIGNEMENT	4	
212243	CONJ. UNIÃO CANTO 90° JT 90° CORNER UNION KIT   KIT D'UNION ANGLE 90°	1	
204389	ESQUADRO INOX CANTO 90° 90° STAINLESS STEEL CORNER   ANGLE EN ACIER INOXYDABLE 90°	2	
213246	CANTO CR S/SB CORNER   ANGLE	4	
212199	CONJ. TOPOS LAT. JT LATERAL END-CAPS KIT   KIT D'EMBOUTS LATÉRAUX	4	
212230	CONJ. TOPOS INTERIOR LAT. JT LATERAL INNER END-CAPS KIT   KIT D'EMBOUTS INTÉRIEUR LATÉRAUX	3	
212201	CONJ. TAMPAS TOPOS LAT. JT LATERAL END-CAP COVERS KIT   KIT DE COUVERTURE POUR EMBOUTS LATÉRAUX	3	
212273	CONJ. TOPOS CENTRAIS N.1 20MM JT N.1 20MM JT CENTRAL END-CAPS KIT   KIT D'EMBOUTS CENTRAUX N.1 20MM JT	4	
212252	CONJ. TOPOS INTERIORES LAT./CENTR. JT-SLIM LAT/CENT INNER END-CAP COVERS KIT   KIT DE COUVERT. POUR EMBOUTS LAT/CENTR INTÉR.	4	
212335	CONJ. TAMPAS TOPOS CENTRAIS JT-SLIM CENTRAL END-CAP COVERS KIT   KIT DE COUVERTURE POUR EMBOUTS CENTRAUX	4	
210231	TOPO CENTRAL REFORÇADO JT56 28MM 28MM CENTRAL REINFORCED END-CAPS KIT   KIT D'EMBOUTS CENTRAUX RENFORCÉ 28MM	8	
212109	CONJ. TOPOS CANTO 90° JT 90° CORNER END-CAPS KIT   KIT D'EMBOUTS POUR ANGLE 90°	1	
210269	GOTEIRA OCULTA C/ VALV. SV-C13 FLAP VALVE   CLAPE À VOLET CACHÉ	(a)	
211223	FERRAGEM MULTIPONTO CENTR. 1000 MULTIPOINT HARDWARE   SERRURE MULTIPONT	3	
202491	CONTRA-FECHO ANTI-LEVANTAMENTO MULTIPONTO STRIKING PLATE   GÂCHE	6	
202487	CENTRADOR JT P/ C-FECHO AL MULTIPONTO JT CENTERING FOR STRIKING PLATE   CENTRAGE JT POUR GÂCHE	4	
212455	CONJ. FIX. CONTRA-FECHO AL MULTIP. JT MULTIPOINT HARDWARE STRIKING PLATE FIXING KIT   KIT FIXATION GÂCHE SERRURE MULTIPONT	4	
212458	CONJ. FIX. CONTRA-FECHO MULTIP. 2F/90° JT MULTIPOINT HARDWARE STRIKING PLATE FIXING KIT   KIT FIXATION GÂCHE SERRURE MULTIP.	2	
218154	CALÇO P/ C-FECHO PERF. LIG CONNECTING PROFILE STRIKING PLATE SHIM   CALE POUR GÂCHE PROFILÉ DE LIAISON	2	
218149	CALÇO N°2 P/ MULTIPONTO SOS JT MULTIPOINT HARDWARE SHIM   CALE POUR MULTIPONT	18	
212161	CONJ. CENTRADOR P/ FERRAGEM JT CENTERING KIT FOR JT HARDWARE   KIT CENTRAGE POUR SERRURE JT	2	
212162	CONJ. CENTRADOR P/ FERRAGEM JT PERFIL LIG CENTERING KIT FOR JT HARDWARE   KIT CENTRAGE POUR SERRURE JT	1	
212371	CONJ. FIXAÇÃO JT FIXING KIT   KIT FIXATION	18	
212079	CONJ. FIX. FERRAGEM MULTIP. JT72 MULTIPOINT FIXING KIT   KIT FIXATION SERRURE MULTIPONT	1 + 1 un./m (min. 4)	
200819	PUXADOR SLIM XS - ESQUERDO LEFT HANDLE   POIGNEE GAUCHE	1	
200817	PUXADOR SLIM XS - DIREITO RIGHT HANDLE   POIGNEE DROITE	2	
212341	CONJ. TOPOS LAT. PINGADEIRA LATERAL DRIP END-CAPS KIT   KIT D'EMBOUTS LATÉRAUX POUR REJET D'EAU	1	
228107	LIMITADOR ABERT. PQ SERIE CORRER OPENING LIMITER   LIMITÉUR D'OUVERTURE	2	
290472	PARAF. AT/PF CQ Ø3.9x19MM SCREW   VIS	1 + 1 un./m	
290262	PARAFUSO PK INOX PH 1 1/2X10 CQ SCREW   VIS	32	
218137	CALÇO REFORÇO HORIZONTAL JT * HORIZONTAL REINFORCEMENT SHIM   CALE DE RENFORCEMENT HORIZONTALE	8	

\* Usar em folhas com vidros com peso superior a 80kg  
To be used in sashes with glass weight over 80kg | Utiliser dans des panneaux de verre d'un poids supérieur à 80 kg

(a) Conforme esquemas de drenagem (Capítulo V - Maquinações)  
According to drainage schemes (Chapter V - Machinings)  
Selon les schémas de drainage (Chapitre V - Usinages)

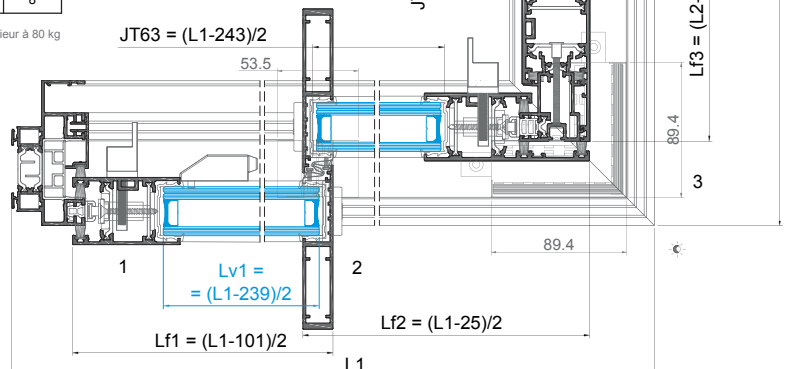
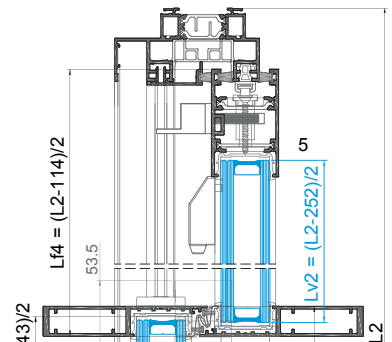
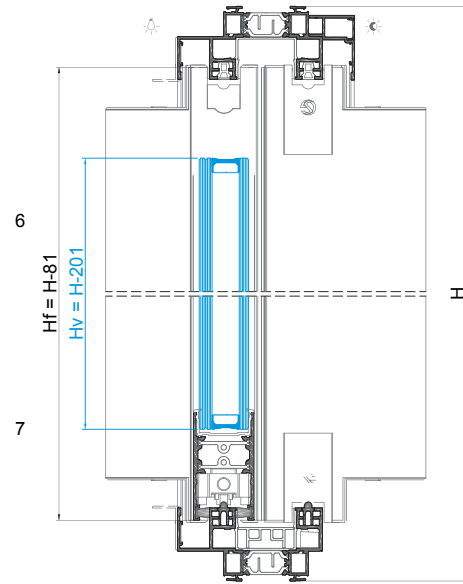
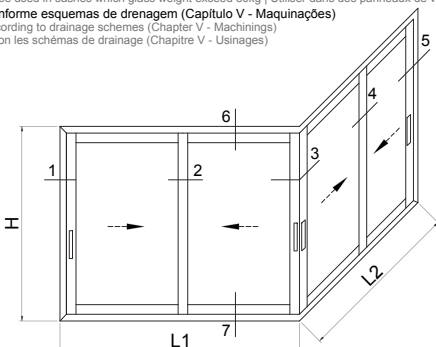



## JANELA DE CORRER 2 FOLHAS JT 2-RAIL COM PERFIS CENTRAIS 20mm - LINHA PT 2 JT SASHES 2-RAIL SLIDING WINDOW WITH 20mm CENTRAL PROFILES - PT LINE FENÊTRE COULISSANT 2 VANTAUX JT 2-RAIL AVEC PROFILÉS CENTRAUX 20mm - LIGNE PT

PERFIS   PROFILÉS   PROFILÉS					
CÓDIGO CODE   CODE	DESIGNAÇÃO DESIGNATION   NOMINATION	CORTE HORIZ. HORIZONTAL CUT COUPE HORIZ.	CORTE VERT. VERTICAL CUT COUPE VERTICALE	QUANT. QUANTITY QUANTITÉ	CORTE CUT COUPE
JT 12	ARO FIXO FIXED FRAME   CADRE DORMANT	L	H	2 + 2	
JT 56	PERFIL CENTRAL CENTRAL PROFILE   PROFILÉ CENTRAL	-	H-74	2	
JT 67	PERFIL LATERAL LATERAL PROFILE   PROFILÉ LATÉRAL	-	H-74	2	
JT 63	TRAVESSA SUP/INF UP/LW TRANSOM   TRAVERSE SUP/INF	(L-183)/2	-	4	
JT 82	PERFIL PINGADEIRA DRIP PROFILE   LARMIER	L-4	-	1	
JT 90	CAPA COVER   CAPOT	-	H-37	1	
JT 92	CAPA COVER   CAPOT	-	H-37	1	
JT 87	GUIA GUIDE   GUIDE	L-93	-	2	
208351	JUNTA CENTRAL 2197 CENTRAL JOINT   JOINT CENTRALE	-	H-74	2	
215305	PERFIL PVC U U PVC PROFILE   PROFILÉ PVC U	L-34	H-34	2 + 2	
215303	PERFIL PVC T T PVC PROFILE   PROFILÉ PVC T	(L-119)/2	H-37	2 + 2	

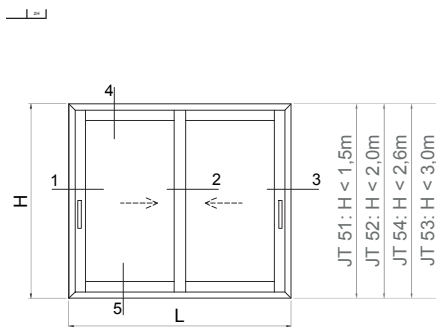

ACESSÓRIOS   ACCESSORIES   ACCESSOIRES		
CÓDIGO CODE   CODE	DESIGNAÇÃO DESIGNATION   NOMINATION	QUANT. QUANTITY QUANTITÉ
205129	CARRINHO JT 180KG ROLLER   ROULETTE	4
213402	CORTA-VENTO JT-SLIM CENTRAL WATERPROOFING BRUSH   BROSSSE CENTRALE D'ÉTANCHÉITÉ	2
212337	CONJ. ESTANQ. CORTA-VENTO JT CENTRAL WATERPROOFING BRUSH KIT   KIT BROSSSE CENTRALE D'ÉTANCHÉITÉ	1
204153	ESQUADRO JT 11x20,5 CORNER CLEAT   ÉQUERRE	8
213246	CANTO CR S/SB CORNER   ANGLE	4
212199	CONJ. TOPOS LAT. JT LATERAL END-CAPS KIT   KIT D'EMBOUTS LATÉRAUX	2
212230	CONJ. TOPOS INTERIOR LAT. JT LATERAL INNER END-CAPS KIT   KIT D'EMBOUTS INTÉRIEUR LATÉRAUX	2
212201	CONJ. TAMPAS TOPOS LAT. JT LATERAL END-CAP COVERS KIT   KIT DE COUVERTURE POUR EMBOUTS LATÉRAUX	2
212273	CONJ. TOPOS CENTRAIS N.1 20MM JT N.1 20MM JT CENTRAL END-CAPS KIT   KIT D'EMBOUTS CENTRAUX N.1 20MM JT	2
212252	CONJ. TOPOS INTERIORES LAT./CENTR. JT-SLIM LAT/CENT INNER END-CAP COVERS KIT   KIT DE COUVERT. POUR EMBOUTS LAT/CENTR INTÉR.	2
212335	CONJ. TAMPAS TOPOS CENTRAIS JT-SLIM CENTRAL END-CAP COVERS KIT   KIT DE COUVERTURE POUR EMBOUTS CENTRAUX	2
210231	TOPO CENTRAL REFORÇADO JT56 28MM 28MM CENTRAL REINFORCED END-CAPS KIT   KIT D'EMBOUTS CENTRAUX RENFORCÉ 28MM	4
210268	GOTEIRA C/ VALV. SVE OUTSIDE FLAP VALVE GLASSE À VOLET EXTERIEUR	(a)
211223	FERRAGEM MULTIPONTO CENTR. 1000 MULTIPOINT HARDWARE   SERRURE MULTIPONTO	2
202491	CONTRA-FECHO ANTI-LEVANTAMENTO MULTIPONTO STRIKING PLATE   GÂCHE	4
202487	CENTRADOR JT P/ C-FECHO AL MULTIPONTO JT CENTERING FOR STRIKING PLATE   CENTRAGE JT POUR GÂCHE	4
212455	CONJ. FIX. CONTRA-FECHO AL MULTIP. JT MULTIPOINT HARDWARE STRIKING PLATE FIXING KIT   KIT FIXATION GÂCHE SERRURE MULTIPONT	4
218149	CALÇO Nº2 P/ MULTIPONTO SOS JT MULTIPOINT HARDWARE SHIM   CALE POUR MULTIPONT	12
212161	CONJ. CENTRADOR P/ FERRAGEM JT CENTERING KIT FOR JT HARDWARE   KIT CENTRAGE POUR SERRURE JT	2
212371	CONJ. FIXAÇÃO JT FIXING KIT   KIT FIXATION	12
200819	PUXADOR SLIM XS - ESQUERDO LEFT HANDLE   POIGNÉE GAUCHE	1
200817	PUXADOR SLIM XS - DIREITO RIGHT HANDLE   POIGNÉE DROITE	1
212384	CONJ. TOPOS LAT. PINGADEIRA JT82 LATERAL DRIP END-CAPS KIT   KIT D'EMBOUTS LATÉRAUX POUR REJET D'EAU	1
228107	LIMITADOR ABERT. PQ SERIE CORRER OPENING LIMITER   LIMITEUR D'OUVERTURE	1
290262	PARAFUSO PK INOX PH 1 1/2X10 CQ SCREW   VIS	8
290091	PARAFUSO DIN7982 PH 4.8x50 A2 SCREW   VIS	8
218137	CALÇO REFORÇO HORIZONTAL JT * HORIZONTAL REINFORCEMENT SHIM   CALE DE RENFORCEMENT HORIZONTALE	4

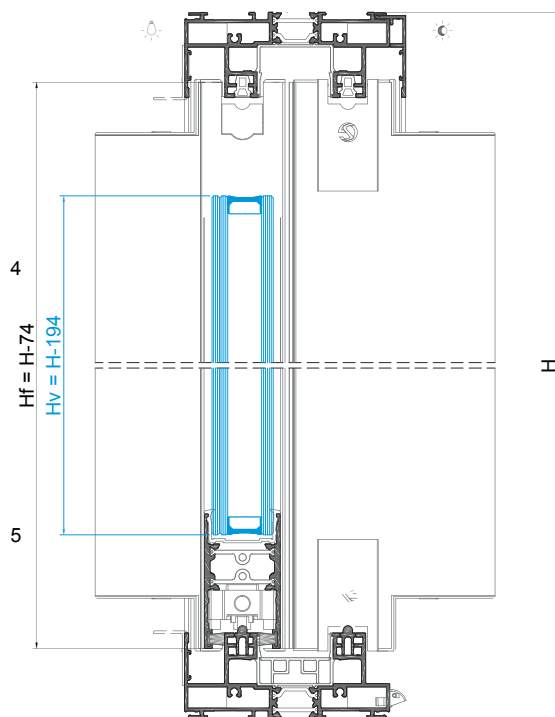

\* Usar em folhas com vidros com peso superior a 80kg  
To be used in sashes which glass weight exceed 80kg | Utiliser dans des panneaux de verre d'un poids supérieur à 80 kg  
(a) Conforme esquemas de drenagem (Capítulo V - Maquinações)  
According to drainage schemes (Chapter V - Machinings) | Selon les schémas de drainage (Chapitre V - Usinages)

VEDANTES   SEALS   JOINTS		
CÓDIGO CODE   CODE	DESIGNAÇÃO DESIGNATION   NOMINATION	QUANT. QUANTITY QUANTITÉ
208348	JUNTA TAPA CANAL 2116 JT JOINT   JOINT	2L + 2H
208099	JUNTA VIDRO U 1032 CX 32MM JT GLAZING GASKET   JOINT DE VITRAGE	2L + 4H
208307	PELÚCIA 7x10 TRI-FIN PRETA PILE SEAL   JOINT BROSSSE	4L + 6H
208469	PELÚCIA SRF 4X8 2P1M Preta PILE SEAL   JOINT BROSSSE	2H

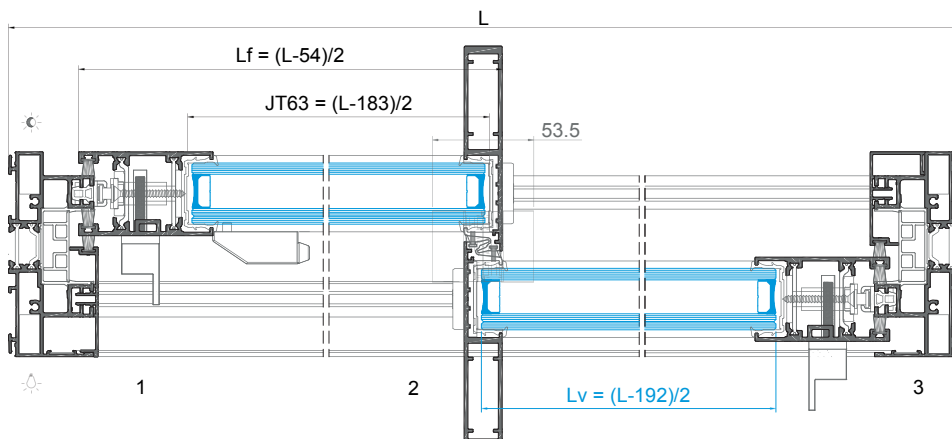

## JANELA DE CORRER 4 FOLHAS JT 2-RAIL COM PERFIS CENTRAIS 20mm E LIGAÇÃO CENTRAL - LINHA PT

### 4 JT SASHES 2-RAIL SLIDING WINDOW WITH 20mm CENTRAL PROFILES AND CENTRAL CONNECTION - PT LINE

### FENÊTRE COULISSANT 4 VANTAUX JT 2-RAIL AVEC PROFILÉS CENTRAUX 20mm ET CONNEXION CENTRALE - LIGNE PT

PERFIS   PROFILES   PROFILÉS					
CÓDIGO CODE   CODE	DESIGNAÇÃO DESIGNATION   NOMINATION	CORTE HORIZ. HORIZONTAL CUT COUPE HORIZ.	CORTE VERT. VERTICAL CUT COUPE VERTICALE	QUANT. QUANTITY QUANTITE	CORTE CUT COUPE
JT 12	ARO FIXO FIXED FRAME   CADRE DORMANT	L	H	2 + 2	
JT 56	PERFIL CENTRAL CENTRAL PROFILE   PROFILÉ CENTRAL	-	H-74	4	
JT 67	PERFIL LATERAL LATERAL PROFILE   PROFILÉ LATÉRAL	-	H-74	4	
JT 63	TRAVESSA SUP/INF UP/LW TRANSOM   TRAVERSE SUP/INF	(L-298)/4	-	8	
JT 71	PERFIL LIGAÇÃO CENTRAL CONNECTION PROFILE   PROFILÉ DE LIAISON	-	H-143	1	
JT 82	PERFIL PINGADEIRA DRIP PROFILE   LARMIER	L-4	-	1	
JT 90	CAPA CAP   CAPOT	-	H-37	2	
JT 87	GUIA GUIDE   GUIDE	L-96 L-90	-	1	
208351	JUNTA CENTRAL 2197 CENTRAL JOINT   JOINT CENTRALE	-	H-74	4	
215305	PERFIL PVC U PVC PROFILE   PROFILÉ PVC U	L-34	H-34	2 + 2	
215303	PERFIL PVC T PVC PROFILE   PROFILÉ PVC T	(L-169)/4 (L-284)/4	H-37	2 + 2	

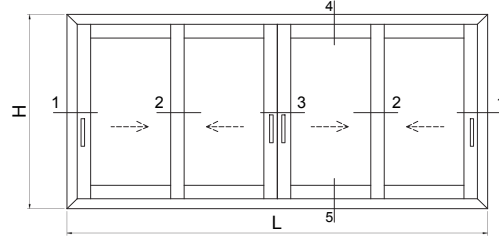

ACESSÓRIOS   ACCESSORIES   ACCESSOIRES			
CÓDIGO CODE   CODE	DESIGNAÇÃO DESIGNATION   NOMINATION		QUANT. QUANTITY QUANTITE
205129	CARRINHO JT 180KG ROLLER   ROULETTE		8
213402	CORTA-VENTO JT-SLIM CENTRAL WATERPROOFING BRUSH   BROSSA CENTRAL DE TANCHÉITÉ		6
212337	CONJ. ESTANQ. CORTA-VENTO JT CENTRAL WATERPROOFING BRUSH KIT   KIT BROSSA CENTRAL DE TANCHÉITÉ		3
204153	ESQUADRO JT 11x20.5 CORNER CLEAT   ÉQUERRE		8
213246	CANTO CR S/SB CORNER   ANGLE		4
212199	CONJ. TOPOS LAT. JT LATERAL END-CAPS KIT   KIT D'EMBOÛTS LATÉRAUX		4
212230	CONJ. TOPOS INTERIOR LAT. JT LATERAL INNER END-CAPS KIT   KIT D'EMBOÛTS INTÉRIEUR LATÉRAUX		3
212201	CONJ. TAMPAS TOPOS LAT. JT LATERAL END-CAP COVERS KIT   KIT DE COUVERTURE POUR EMBOUTS LATÉRAUX		3
212273	CONJ. TOPOS CENTRAIS N.1 20MM JT N1 20MM JT CENTRAL END-CAPS KIT   KIT D'EMBOÛTS CENTRAUX N.1 20MM JT		4
212252	CONJ. TOPOS INTERIORES LAT./CENTR. JT-SLIM LATERAL INNER END-CAP COVERS KIT   KIT DE COUVERT. POUR EMBOUTS LAT/CENTR INTÉR.		4
212335	CONJ. TAMPAS TOPOS CENTRAIS JT-SLIM CENTRAL END-CAP COVERS KIT   KIT DE COUVERTURE POUR EMBOUTS CENTRAUX		4
210231	TOPO CENTRAL REFORÇADO JT56 28MM 28MM CENTRAL REINFORCED END-CAPS KIT   KIT D'EMBOÛTS CENTRAUX RENFORCÉ 28MM		8
212104	CONJ. TOPOS LIG. 2 FOLHAS JT 2 SASHES CONNECTING END-CAPS KIT   KIT D'EMBOÛTS CONNEXION 2 VANTAUX		1
210268	GOTEIRA C/ VALV. SVE OUTSIDE FLAP VALVE   CLAPE À VOLET EXTÉRIEUR		(a)
211223	FERRAGEM MULTIPONTO CENTR. 1000 MULTIPOINT HARDWARE   SERRURE MULTIPOINT		3
202491	CONTRA-FECHO ANTI-LEVANTAMENTO MULTIPONTO STRIKING PLATE   GÂCHE		6
202487	CENTRADOR JT P/ C-FECHO AL MULTIPONTO JT CENTERING FOR STRIKING PLATE   CENTRAGE JT POUR GÂCHE		4
212455	CONJ. FIX. CONTRA-FECHO AL MULTIP. JT MULTIPOINT HARDWARE STRIKING PLATE FIXING KIT   KIT FIXATION GÂCHE SERRURE MULTIPOINT		4
212458	CONJ. FIX. CONTRA-FECHO MULTIP. 2F/90° JT MULTIPOINT HARDWARE STRIKING PLATE FIXING KIT   KIT FIXATION GÂCHE SERRURE MULTIP.		2
218154	CALÇO P/ C-FECHO PERF. LIG CONNECTING PROFILE STRIKING PLATE SHIM   CALE POUR GÂCHE PROFILÉ DE LIAISON		2
218149	CALÇO Nº2 P/ MULTIPONTO SOS JT MULTIPOINT HARDWARE SHIM   CALE POUR MULTIPOINT		18
212161	CONJ. CENTRADOR P/ FERRAGEM JT CENTERING KIT FOR JT HARDWARE   KIT CENTRAGE POUR SERRURE JT		2
212162	CONJ. CENTRADOR P/ FERRAGEM JT PERFIL LIG. CENTERING KIT FOR JT HARDWARE   KIT CENTRAGE POUR SERRURE JT		1
212371	CONJ. FIXAÇÃO JT FIXING KIT   KIT FIXATION		18
212017	CONJ. FIX. FERRAGEM MULTIP. MULTIPOINT HARDWARE FIXING KIT   KIT FIXATION POUR SERRURE MULTIPOINT		1 + 1 un./m (min. 4)
200819	PUXADOR SLIM XS - ESQUERDO LEFT HANDLE   POIGNÉE GAUCHE		1
200817	PUXADOR SLIM XS - DIREITO RIGHT HANDLE   POIGNÉE DROITE		2
200057	PUXADOR FOLHA PASSIVA SLIM XS PASSIVE SASH HANDLE   POIGNÉE VENTAIL PASSIVE		1
212384	CONJ. TOPOS LAT. PINGADEIRA JT82 LATERAL DRIP END-CAPS KIT   KIT D'EMBOÛTS LATÉRAUX POUR REJET D'EAU		1
228107	LIMITADOR ABERT. PQ SERIE CORRER OPENING LIMITER   LIMITEUR D'OUVERTURE		2
290262	PARAFUSO PK INOX PH 1 1/2X10 CQ SCREW   VIS		32
218137	CALÇO REFORÇO HORIZONTAL JT * HORIZONTAL REINFORCEMENT SHIM   CALE DE RENFORCEMENT HORIZONTALE		8

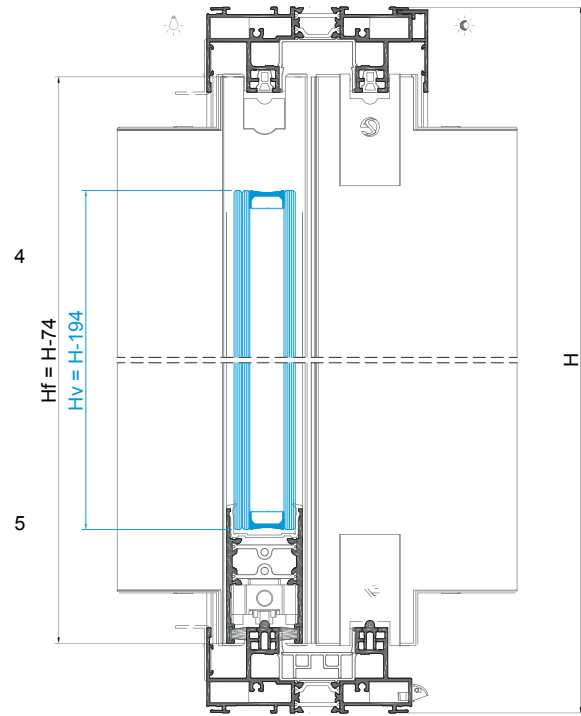

VEDANTES   SEALS   JOINTS			
CÓDIGO CODE   CODE	DESIGNAÇÃO DESIGNATION   NOMINATION		QUANT. QUANTITY QUANTITE
208348	JUNTA TAPA CANAL 2116 JT JOINT   JOINT		2L + 2H
208099	JUNTA VIDRO U 1032 CX 32MM JT GLAZING GASKET   JOINT DE VITRAGE		2L + 8H
208307	PELÚCIA 7x10 TRI-FIN PRETA PILE SEAL   JOINT BRUSSE		4L + 10H
208469	PELÚCIA SRF 4X8 2P1M Preta PILE SEAL   JOINT BRUSSE		4H
208479	JUNTA TAPA CANAL PERFIL LIG. 2117 JT JOINT   JOINT		H

\* Usar em folhas com vidros com peso superior a 80kg  
To be used in sashes with glass weight exceed 80kg | Utiliser dans des panneaux de verre d'un poids supérieur à 80 kg  
(a) Conforme esquemas de drenagem (Capítulo V - Maquinações)  
According to drainage schemes (Chapter V - Machinings) | Selon les schémas de drainage (Chapitre V - Usinages)

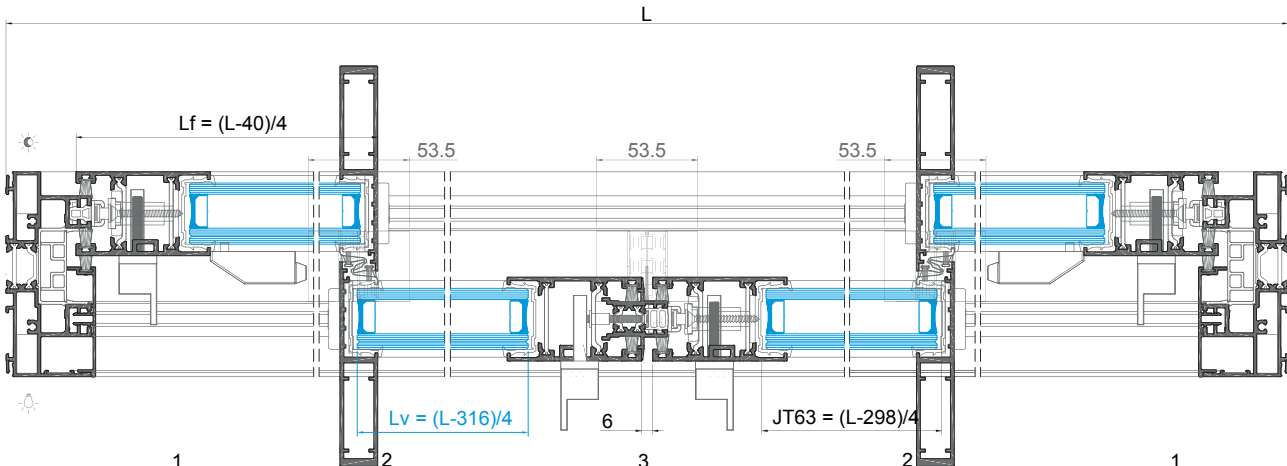

## JANELA DE CORRER 4 FOLHAS 2-RAIL CANTO 90° COM PERFIS CENTRAIS 20mm - LINHA PT

### 4 SASHES 2-RAIL SLIDING WINDOW WITH 20mm CENTRAL PROFILES IN 90° CORNER - PT LINE

### FENÊTRE COULISSANT 4 VANTAUX JT 2-RAIL AVEC PROFILÉS CENTRAUX 20mm À ANGLE 90° - LIGNE PT

PERFIS   PROFILES   PROFILÉS					
CÓDIGO CODE   CODE	DESIGNAÇÃO DESIGNATION   NOMINATION	CORTE HORIZ. HORIZONTAL CUT COUPE HORIZ.	CORTE VERT. VERTICAL CUT COUPE VERTICALE	QUANT. QUANTITY QUANTITE	CORTE CUT COUPE
JT-12	ARO FIXO FIXED FRAME   CADRE DORMANT	L1 L2	H	2 + 2	
JT-56	PERFIL CENTRAL CENTRAL PROFILE   PROFILÉ CENTRAL	-	H-74	4	
JT-67	PERFIL LATERAL LATERAL PROFILE   PROFILÉ LATÉRAL	-	H-74	2	
JT-62	PERFIL LATERAL CANTO 90° 90° CORNER LAT. PR.   PR. LAT. D'ANGLE À 90°	-	H-74	2	
JT-63	TRAVESSA SUP/INF UP/LOW TRANSOM   TRAVERSE SUP/INF	(L1-241)/2 (L2-252)/2	-	4 4	
JT-72	PERFIL LIGAÇÃO CANTO 90° CONNECTION PROFILE   PROFILÉ DE LIAISON	-	H-143	1	
JT-82	PERFIL PINGADEIRA Drip Profile   LARMIER	L1+19 L2+19	-	1 1	
JT-90	CAPA COVER   CAPOT	-	H-37	2	
JT-87	GUIA GUIDE   GUIDE	L1-48 L1-106 L2-46 L2-106	-	1 1 1 1	
208351	JUNTA CENTRAL 2197 CENTRAL JOINT   JOINT CENTRALE	-	H-74	4	
215305	PERFIL PVC U U PVC PROFILE   PROFILÉ PVC U	L1-34 L2-34	H-34	2 + 2	
215303	PERFIL PVC T T PVC PROFILE   PROFILÉ PVC T	(L1-176)/2 (L1-240)/2 (L2-227)/2 (L2-189)/2	H-37	1 1 + 2 1 1	

VEDANTES   SEALS   JOINTS		
CÓDIGO CODE   CODE	DESIGNAÇÃO DESIGNATION   NOMINATION	QUANT. QUANTITY QUANTITE
208348	JUNTA TAPA CANAL 2116 JT JOINT JOINT	2L1 2L2 + 2H
208099	JUNTA VIDRO U 1032 CX 32MM JT GLAZING GASKET   JOINT DE VITRAGE	2L1 + 8H 2L2 + 8H
208307	PELÚCIA 7x10 TRI-FIN PRETA FILG SEAL   JOINT BRUSSE	4L1 + 11H 4L2
208469	PELÚCIA SRF 4X8 2P1M Preta PILE SEAL   JOINT BRUSSE	4H
208479	JUNTA TAPA CANAL PERFIL LIG. 2117 JT JOINT JOINT	H
208435	JUNTA VD 2415 JOINT JOINT	H

As fórmulas foram concebidas para medidas de vidros iguais. Nesta tipologia existem 4 larguras de folha distintas: Lf1, Lf2, Lf3 e Lf4. The formulas were designed for glasses with equal measures. In this typology there are 4 distinct sash widths: Lf1, Lf2, Lf3 and Lf4. Les formules sont conçues pour mesurer le verre. Dans cette typologie, il existe 4 largeurs de vantaux distinctes: Lf1, Lf2, Lf3 et Lf4.

ACESSÓRIOS   ACCESSORIES   ACCESSOIRES		
CÓDIGO CODE   CODE	DESIGNAÇÃO DESIGNATION   NOMINATION	QUANT. QUANTITY QUANTITE
205129	CARRINHO JT 180KG ROLLER   ROULETTE	8
213402	CORTA-VENTO JT-SLIM CENTRAL WATERPROOFING BRUSH   BRUSSE CENTRALE D'ETANCHÉITÉ	4
213287	CORTA-VENTO CANTO 90° JT 90° CORNER WATERPROOFING BRUSH   BRUSSE D'ETANCHÉITÉ ANGLE 90°	2
212337	CONJ. ESTANQ. CORTA-VENTO JT CENTRAL WATERPROOFING BRUSH KIT   KIT BRUSSE CENTRALE D'ETANCHÉITÉ	4
204153	ESQUADRO JT 11x20.5 CORNER CLEAT   EQUERRE	8
212243	CONJ. UNIÃO CANTO 90° JT 90° CORNER UNION KIT   KIT D'UNION ANGLE 90°	1
204389	ESQUADRO INOX CANTO 90° 90° STAINLESS STEEL CORNER   ANGLE EN ACIER INOXYDABLE 90°	2
213246	CANTO CR S/SB CORNER   ANGLE	4
212199	CONJ. TOPOS LAT. JT LATERAL END-CAPS KIT   KIT D'EMBOUTS LATÉRAUX	4
212230	CONJ. TOPOS INTERIOR LAT. JT LATERAL INNER END-CAPS KIT   KIT D'EMBOUTS INTÉRIEUR LATÉRAUX	3
212201	CONJ. TAMPAS TOPOS LAT. JT LATERAL END-CAP COVERS KIT   KIT DE COUVERTURE POUR EMBOUTS LATÉRAUX	3
212273	CONJ. TOPOS CENTRAIS N.1 20MM JT N1 20MM JT CENTRAL END-CAPS KIT   KIT D'EMBOUTS CENTRAUX N.1 20MM JT	4
212252	CONJ. TOPOS INTERIORES LAT./CENTR. JT-SLIM LAT/CENT INNER END-CAP COVERS KIT   KIT DE COUVERT. POUR EMBOUTS LAT/CENTR INTÉR.	4
212335	CONJ. TAMPAS TOPOS CENTRAIS JT-SLIM CENTRAL END-CAP COVERS KIT   KIT DE COUVERTURE POUR EMBOUTS CENTRAUX	4
210231	TOPO CENTRAL REFORÇADO JT56 28MM 28MM CENTRAL REINFORCED END-CAPS KIT   KIT D'EMBOUTS CENTRAUX RENFORCÉ 28MM	8
212109	CONJ. TOPOS CANTO 90° JT 90° CORNER END-CAPS KIT   KIT D'EMBOUTS POUR ANGLE 90°	1
210268	GOTEIRA C/ VALV. SVE OUTSIDE FLAP VALVE   GÂCHE À VOLET EXTÉRIEUR	(a)
211223	FERRAGEM MULTIPONTO CENTR. 1000 MULTIPOINT HARDWARE   SERRURE MULTIPONT	3
202491	CONTRA-FECHO ANTI-LEVANTAMENTO MULTIPONTO STRIKING PLATE   GÂCHE	6
202487	CENTRADOR JT P/ C-FECHO AL MULTIPONTO JT CENTERING FOR STRIKING PLATE   CENTRAGE JT POUR GÂCHE	4
212455	CONJ. FIX. CONTRA-FECHO AL MULTIP. JT MULTIPOINT HARDWARE STRIKING PLATE FIXING KIT   KIT FIXATION GÂCHE SERRURE MULTIPONT	4
212458	CONJ. FIX. CONTRA-FECHO MULTIP. 2F/90° JT MULTIPOINT HARDWARE STRIKING PLATE FIXING KIT   KIT FIXATION GÂCHE SERRURE MULTIP.	2
218154	CALÇO P/ C-FECHO PERF. LIG CONNECTING PROFILE STRIKING PLATE SHIM   CALE POUR GÂCHE PROFILÉ DE LIAISON	2
218149	CALÇO N°2 P/ MULTIPONTO SOS JT MULTIPOINT HARDWARE SHIM   CALE POUR MULTIPONT	18
212161	CONJ. CENTRADOR P/ FERRAGEM JT CENTERING KIT FOR JT HARDWARE   KIT CENTRAGE POUR SERRURE JT	2
212162	CONJ. CENTRADOR P/ FERRAGEM JT PERFIL LIG. CENTERING KIT FOR JT HARDWARE   KIT CENTRAGE POUR SERRURE JT	1
212371	CONJ. FIXAÇÃO JT FIXING KIT   KIT FIXATION	18
212079	CONJ. FIX. FERRAGEM MULTIP. JT72 MULTIPOINT FIXING KIT   KIT FIXATION SERRURE MULTIPONT	1 + 1 un./m (min. 4)
200819	PUXADOR SLIM XS - ESQUERDO LEFT HANDLE   POIGNÉE GAUCHE	1
200817	PUXADOR SLIM XS - DIREITO RIGHT HANDLE   POIGNÉE DROITE	2
212384	CONJ. TOPOS LAT. PINGADEIRA JT82 LATERAL DRIP END-CAPS KIT   KIT D'EMBOUTS LATÉRAUX POUR REJET D'EAU	1
228107	LIMITADOR ABERT. PQ SERIE CORRER OPENING LIMITER   LIMITEUR D'OUVERTURE	2
290262	PARAFUSO PK INOX PH 1 1/2X10 CQ SCREW   VIS	32
218137	CALÇO REFORÇO HORIZONTAL JT * HORIZONTAL REINFORCEMENT SHIM   CALE DE RENFORCEMENT HORIZONTALE	8

\* Usar em folhas com vidros com peso superior a 80kg  
To be used in sashes which glass weight exceed 80kg | Utiliser dans des panneaux de verre d'un poids supérieur à 80 kg  
(a) Conforme esquemas de drenagem (Capítulo V - Maquinações)  
According to drainage schemes (Chapter V - Machinings) | Selon les schémas de drainage (Chapitre V - Usinages)

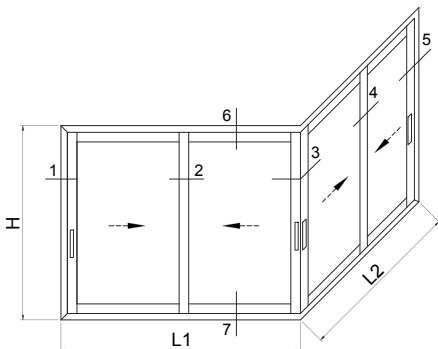
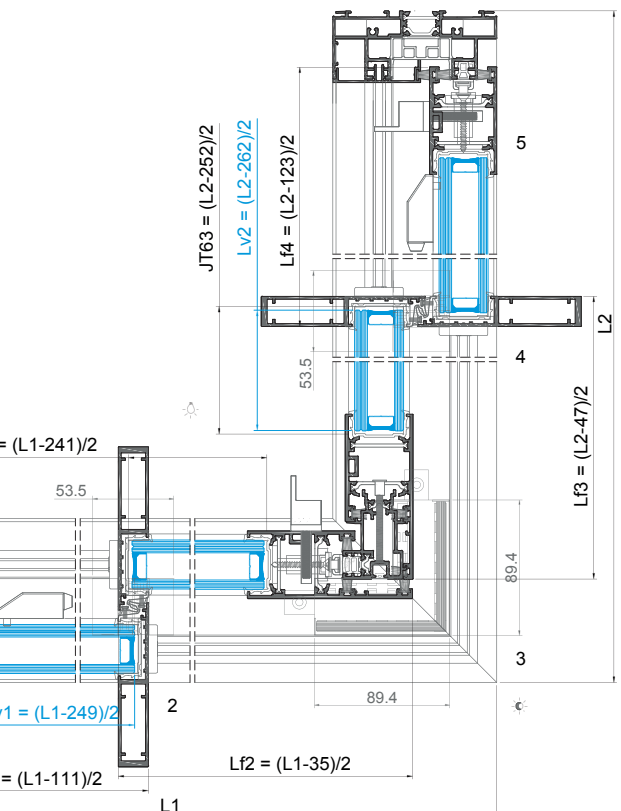
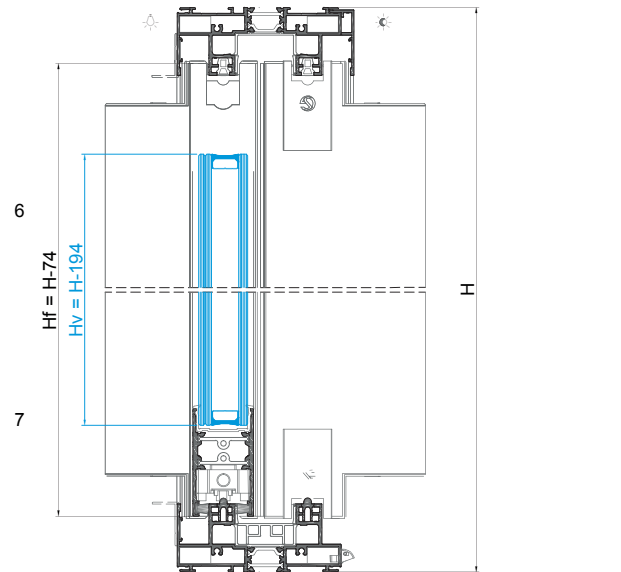

## JANELA DE CORRER 2 FOLHAS JT 2-RAIL COM OMBREIRA JT18 E CENTRAIS 20mm - LINHA SOLEIRA 30MM

### 2 JT SASHES 2-RAIL WITH JT18 JAMB SLIDING WINDOW WITH 20mm CENTRAL PROFILES - 30MM SILL LINE

### FENÊTRE COULISSANT 2 VANTAUX JT 2-RAIL AVEC JAMBAGE JT18 AVEC PROFILÉS CENTRAUX 20mm - LIGNE SEUIL 30MM

PERFIS   PROFILES   PROFILÉS					
CÓDIGO CODE   CODE	DESIGNAÇÃO DESIGNATION   NOMINATION	CORTE HORIZ. HORIZONTAL CUT COUPE HORIZ.	CORTE VERT. VERTICAL CUT COUPE VERTICALE	QUANT. QUANTITY QUANTITE	CORTE CUT COUPE
JT 12	PADIEIRA LINTEL   LINTEAU	L-39	-	1	
JT 18	OMBREIRA JAMB   JAMBAGE	-	H	2	
JT 78	GUIA DA OMBREIRA JAMB GUIDE   GUIDE POUR JAMBAGE	-	H-74	2	
JT 22	SOLEIRA SILL   SEUIL	L-39	-	1	
JT 56	PERFIL CENTRAL CENTRAL PROFILE   PROFILÉ CENTRAL	-	H-59	2	
JT 67	PERFIL LATERAL LATERAL PROFILE   PROFILÉ LATÉRAL	-	H-59	2	
JT 63	TRAVESSA SUP/INF UP/LW TRANSOM   TRAVERSE SUP/INF	(L-157)/2	-	4	
JT 82	PERFIL PINGADEIRA DRIP PROFILE   L'ARMIER	L-4	-	1	
JT 87	GUIA GUIDE   GUIDE	L-51	-	2	
JE 96	PERFIL POLIAMIDA POLYAMIDE PROFILE   PROFILÉ DE POLYAMIDE	(L58)/2	H	2 + 2	
208351	JUNTA CENTRAL 2197 CENTRAL JOINT   JOINT CENTRALE	-	H-59	2	
215305	PERFIL PVC U U PVC PROFILE   PROFILÉ PVC U	L-39	-	1	

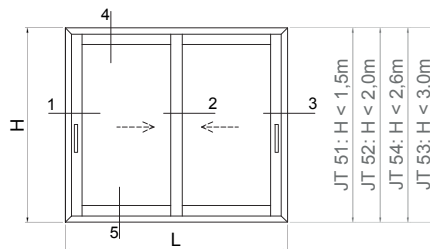

ACESSÓRIOS   ACCESSORIES   ACCESSOIRES		
CÓDIGO CODE   CODE	DESIGNAÇÃO DESIGNATION   NOMINATION	QUANT. QUANTITY QUANTITE
205129	CARRINHO JT 180KG ROLLER   ROULETTE	4
213402	CORTA-VENTO JT-SLIM CENTRAL WATERPROOFING BRUSH   BRASSE CENTRALE D'ETANCHÉITÉ	1
213288	CORTA-VENTO BAIXO JT LOW CENTRAL WATERPROOFING BRUSH   BRASSE CENTRALE D'ETANCHÉITÉ BAS	1
223105	KIT JUNTAS ADESIVAS Nº1 JT JT Nº1 ADHESIVE JOINTS KIT   KIT DE JOINTS ADHÉSIFS Nº1 JT	1
212199	CONJ. TOPOS LAT. JT LATERAL END-CAPS KIT   KIT D'EMBOUTS LATÉRAUX	2
212230	CONJ. TOPOS INTERIOR LAT. JT LATERAL INNER END-CAPS KIT   KIT D'EMBOUTS INTÉRIEUR LATÉRAUX	2
212201	CONJ. TAMPAS TOPOS LAT. JT LATERAL END-CAP COVERS KIT   KIT DE COUVERTURE POUR EMBOUTS LATÉRAUX	2
212273	CONJ. TOPOS CENTRAIS N.1 20MM JT N1 20MM JT CENTRAL END-CAPS KIT   KIT D'EMBOUTS CENTRAUX N.1 20MM JT	2
212252	CONJ. TOPOS INTERIORES LAT./CENTR. JT-SLIM L'ATENT INNER END-CAP COVERS KIT   KIT DE COUVERT. POUR EMBOUTS LAT/CENTR INTÉR.	2
212335	CONJ. TAMPAS TOPOS CENTRAIS JT-SLIM CENTRAL END-CAP COVERS KIT   KIT DE COUVERTURE POUR EMBOUTS CENTRAUX	2
210231	TOPO CENTRAL REFORÇADO JT56 28MM 28MM CENTRAL REINFORCED END-CAPS KIT   KIT D'EMBOUTS CENTRAUX RENFORCÉ 28MM	4
210268	GOTEIRA C/ VALV. SVE OUTSIDE FLAP VALVE   CLAPE À VOLET EXTERIEUR	(a)
211223	FERRAGEM MULTIPONTO CENTR. 1000 MULTIPOINT HARDWARE   SERRURE MULTIPONT	2
202491	CONTRA-FECHO ANTI-LEVANTAMENTO MULTIPONTO STRIKING PLATE   GÂCHE	4
202487	CENTRADOR JT P/ C-FECHO AL MULTIPONTO JT CENTERING FOR STRIKING PLATE   CENTRAGE JT POUR GÂCHE	4
212455	CONJ. FIX. CONTRA-FECHO AL MULTIP. JT MULTIPOINT HARDWARE STRIKING PLATE FIXING KIT   KIT FIXATION GÂCHE SERRURE MULTIPONT	4
218149	CALÇO Nº2 P/ MULTIPONTO SOS JT MULTIPOINT HARDWARE SHIM   CALE POUR MULTIPONT	12
212161	CONJ. CENTRADOR P/ FERRAGEM JT CENTERING KIT FOR JT HARDWARE   KIT CENTRAGE POUR SERRURE JT	2
212371	CONJ. FIXAÇÃO JT FIXING KIT   KIT FIXATION	12
200819	PUXADOR SLIM XS - ESQUERDO LEFT HANDLE   POIGNEE GAUCHE	1
200817	PUXADOR SLIM XS - DIREITO RIGHT HANDLE   POIGNEE DROITE	1
212384	CONJ. TOPOS LAT. PINGADEIRA JT82 LATERAL DRIP END-CAPS KIT   KIT D'EMBOUTS LATÉRAUX POUR REJET D'EAU	1
228107	LIMITADOR ABERT. PQ SERIE CORRER OPENING LIMITER   LIMITEUR D'OUVREURE	1
290052	PARAF DIN7982 PH 3,5x16 A2 SCREW   VIS	1 + 4 un./m
290262	PARAFUSO PK INOX PH 1 1/2x10 CQ SCREW   VIS	16
290030	PARAFUSO DIN7981 4,2x38 INOX A2 SCREW   VIS	8
218137	CALÇO REFORÇO HORIZONTAL JT * HORIZONTAL REINFORCEMENT SHIM   CALE DE RENFORCEMENT HORIZONTALE	4

\* Usar em folhas com vidros com peso superior a 80kg  
To be used in sashes which glass weight exceed 80kg | Utiliser dans des panneaux de verre d'un poids supérieur à 80 kg

(a) Conforme esquemas de drenagem (Capítulo V - Maquinações)  
According to drainage schemes (Chapter V - Machinings) | Selon les schémas de drainage (Chapitre V - Usinages)

VEDANTES   SEALS   JOINTS		
CÓDIGO CODE   CODE	DESIGNAÇÃO DESIGNATION   NOMINATION	QUANT. QUANTITY QUANTITE
208348	JUNTA TAPA CANAL 2116 JT JOINT JOINT	2L + 2H
208099	JUNTA VIDRO U 1032 CX 32MM JT GLAZING GASKET   JOINT DE VITRAGE	2L + 4H
208307	PELÚCIA 7x10 TRI-FIN PRETA PILE SEAL   JOINT BROUSSE	4L + 4H
208469	PELÚCIA SRF 4X8 2P1M Preta PILE SEAL   JOINT BROUSSE	2H

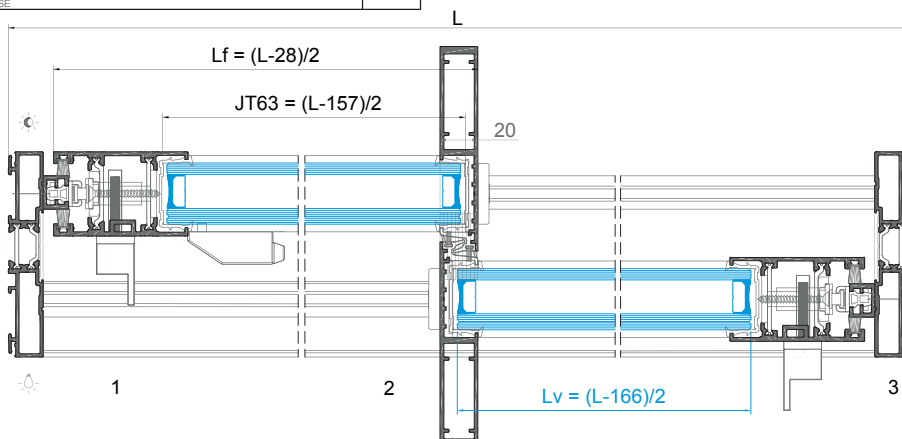
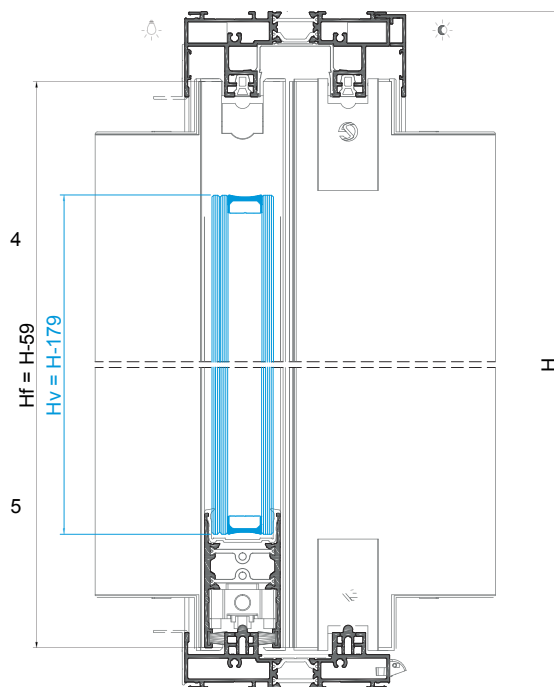



JANELA DE CORRER 4 FOLHAS 2-RAIL JT COM OMBREIRA JT18 E CENTRAIS 20mm COM LIGAÇÃO CENTRAL - LINHA SOLEIRA 30MM  
 4 JT SASHES 2-RAIL AND JT18 JAMB SLIDING WINDOW WITH 20mm CENTRAL PROFILES AND CENTRAL CONNECTION - 30MM SILL LINE  
 FENÊTRE COULISSANT 4 VANTAUX JT 2-RAIL AVEC JAMBAGE JT18 ET PROFILÉS CENTRAUX 20mm AVEC CONNEXION CENTRALE - LIGNE SEUIL 30MM

PERFIS   PROFILES   PROFILÉS					
CÓDIGO CODE   CODE	DESIGNAÇÃO DESIGNATION   NOMINATION	CORTE HORIZ. HORIZONTAL CUT COUPE HORIZ.	CORTE VERT. VERTICAL CUT COUPE VERTICALE	QUANT. QUANTITY QUANTITE	CORTE CUT COUPE
JT 12	PADEIRA LINTEL   LINTEAU	L-39	-	1	
JT 18	OMBREIRA JAMB   JAMBAGE	-	H	2	
JT 78	GUIA DA OMBREIRA JAMB GUIDE   GUIDE POUR JAMBAGE	-	H-74	2	
JT 22	SOLEIRA SILL   SEUIL	L-39	-	1	
JT 56	PERFIL CENTRAL CENTRAL PROFILE   PROFILÉ CENTRAL	-	H-59	4	
JT 67	PERFIL LATERAL LATERAL PROFILE   PROFILÉ LATÉRAL	-	H-59	4	
JT 63	TRAVESSA SUP/INF UP/LW TRANSOM   TRAVERSE SUP/INF	(L-272)/4	-	8	
JT 71	PERFIL LIGAÇÃO CENTRAL CONNECTION PROFILE   PROFILÉ DE LIAISON	-	H-128	1	
JT 82	PERFIL PINGADEIRA DRIP PROFILE   LARMIER	L-4	-	1	
JT 87	GUIA GUIDE   GUIDE	L-65 L-38	-	1 1	
JE 96	PERFIL POLIAMIDA POLYAMIDE PROFILE   PROFILÉ DE POLYAMIDE	(L-74)/4 (L-154)/4	H	2 + 2	
208351	JUNTA CENTRAL 2197 CENTRAL JOINT   JOINT CENTRALE	-	H-59	4	
215305	PERFIL PVC U U PVC PROFILE   PROFILÉ PVC U	L-39	-	1	

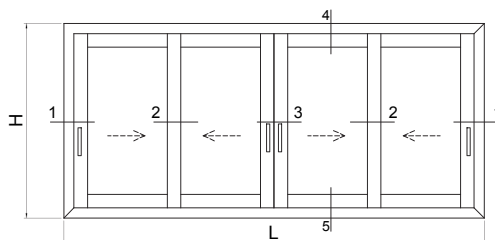

ACESSÓRIOS   ACCESSORIES   ACCESSOIRES			
CÓDIGO CODE   CODE	DESIGNAÇÃO DESIGNATION   NOMINATION	QUANT. QUANTITY QUANTITE	
205129	CARRINHO JT 180KG ROLLER   ROULETTE	8	
213402	CORTA-VENTO JT-SLIM CENTRAL WATERPROOFING BRUSH   BROSSSE CENTRALE D'ETANCHÉITÉ	3	
213288	CORTA-VENTO BAIXO JT LOW CENTRAL WATERPROOFING BRUSH   BROSSSE CENTRALE D'ETANCHÉITÉ BAS	3	
223105	KIT JUNTAS ADESIVAS Nº1 JT JT Nº1 ADHESIVE JOINTS KIT   KIT DE JOINTS ADHÉSIFS Nº1 JT	1	
212199	CONJ. TOPOS LAT. JT LATERAL END-CAPS KIT   KIT D'EMBOUITS LATÉRAUX	4	
212230	CONJ. TOPOS INTERIOR LAT. JT LATERAL INNER END-CAPS KIT   KIT D'EMBOUITS INTÉRIEUR LATÉRAUX	3	
212201	CONJ. TAMPAS TOPOS LAT. JT LATERAL END-CAP COVERS KIT   KIT DE COUVERTURE POUR EMBOUTS LATÉRAUX	3	
212273	CONJ. TOPOS CENTRAIS N.1 20MM JT N.1 20MM JT CENTRAL END-CAPS KIT   KIT D'EMBOUITS CENTRAUX N.1 20MM JT	4	
212252	CONJ. TOPOS INTERIORES LAT./CENTR. JT-SLIM LAT/CENT INNER END-CAP COVERS KIT   KIT DE COUVERT. POUR EMBOUTS LAT/CENTR INTÉR.	4	
212335	CONJ. TAMPAS TOPOS CENTRAIS JT-SLIM CENTRAL END-CAP COVERS KIT   KIT DE COUVERTURE POUR EMBOUTS CENTRAUX	4	
210231	TOPO CENTRAL REFORÇADO JT56 28MM 28MM CENTRAL REINFORCED END-CAPS KIT   KIT D'EMBOUITS CENTRAUX RENFORCÉ 28MM	8	
212104	CONJ. TOPOS LIG. 2 FOLHAS JT 2 SASHES CONNECTING END-CAPS KIT   KIT D'EMBOUITS CONNEXION 2 VENTAUX	1	
210268	GOTEIRA C/ VALV. SVE OUTSIDE FLAP VALVE   CLAPE À VOLET EXTÉRIEUR	(a)	
211223	FERRAGEM MULTIPONTO CENTR. 1000 MULTIPOINT HARDWARE   SERRURE MULTIPONTO	3	
202491	CONTRA-FECHO ANTI-LEVANTAMENTO MULTIPONTO STRIKING PLATE   GÂCHE	6	
202487	CENTRADOR JT P/ C-FECHO AL MULTIPONTO JT CENTERING FOR STRIKING PLATE   CENTRAGE JT POUR GÂCHE	4	
212455	CONJ. FIX. CONTRA-FECHO AL MULTIP. JT MULTIPOINT HARDWARE STRIKING PLATE FIXING KIT   KIT FIXATION GÂCHE SERRURE MULTIPONTO	4	
212458	CONJ. FIX. CONTRA-FECHO MULTIP. 2F/90º JT MULTIPOINT HARDWARE STRIKING PLATE FIXING KIT   KIT FIXATION GÂCHE SERRURE MULTIP.	2	
218154	CALÇO P/ C-FECHO PERF. LIG CONNECTING PROFILE STRIKING PLATE SHIM   CALE POUR GÂCHE PROFILÉ DE LIAISON	2	
218149	CALÇO Nº2 P/ MULTIPONTO SOS JT MULTIPOINT HARDWARE SHIM   CALE POUR MULTIPONTO	18	
212161	CONJ. CENTRADOR P/ FERRAGEM JT CENTERING KIT FOR JT HARDWARE   KIT CENTRAGE POUR SERRURE JT	2	
212162	CONJ. CENTRADOR P/ FERRAGEM JT PERF LIG. CENTERING KIT FOR JT HARDWARE   KIT CENTRAGE POUR SERRURE JT	1	
212371	CONJ. FIXAÇÃO JT FIXING KIT   KIT FIXATION	18	
212017	CONJ. FIX. FERRAGEM MULTIP. MULTIPOINT HARDWARE FIXING KIT   KIT FIXATION POUR SERRURE MULTIPONTO	1 + 1 un./m (min. 4)	
200819	PUXADOR SLIM XS - ESQUERDO LEFT HANDLE   POIGNÉE GAUCHE	1	
200817	PUXADOR SLIM XS - DIREITO RIGHT HANDLE   POIGNÉE DROITE	2	
200057	PUXADOR FOLHA PASSIVA SLIM XS PASSIVE SASH HANDLE   POIGNÉE VENTALE PASSIVE	1	
212384	CONJ. TOPOS LAT. PINGADEIRA JT82 LATERAL DRIP END-CAPS KIT   KIT D'EMBOUITS LATÉRAUX POUR REJET D'EAU	1	
228107	LIMITADOR ABERT. PQ SERIE CORRER OPENING LIMITER   LIMITEUR D'OUVERTURE	2	
290052	PARAF DIN7982 PH 3,5x16 A2 SCREW   VIS	1 + 4 un./m	
290262	PARAFUSO PK INOX PH 1 1/2x10 CQ SCREW   VIS	32	
290030	PARAFUSO DIN7981 4,2x38 INOX A2 SCREW   VIS	8	
218137	CALÇO REFORÇO HORIZONTAL JT * HORIZONTAL REINFORCEMENT SHIM   CALE DE RENFORCEMENT HORIZONTALE	8	

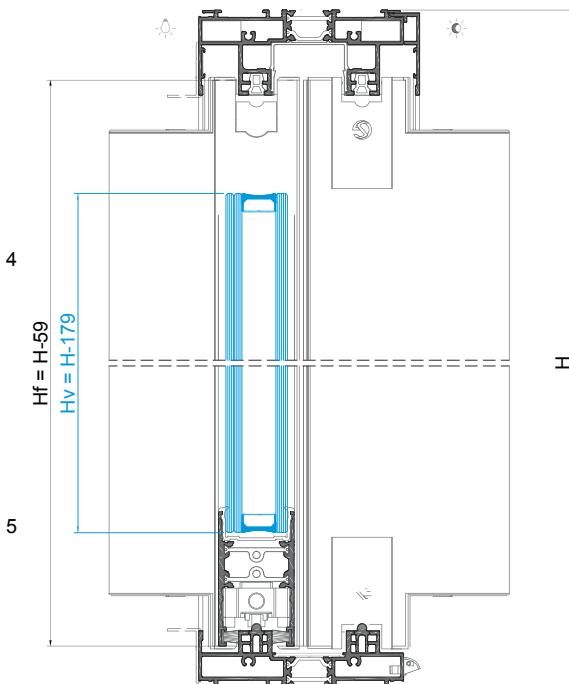

VEDANTES   SEALS   JOINTS		
CÓDIGO CODE   CODE	DESIGNAÇÃO DESIGNATION   NOMINATION	QUANT. QUANTITY QUANTITE
208348	JUNTA TAPA CANAL 2116 JT JOINT   JOINT	2L + 2H
208099	JUNTA VIDRO U 1032 CX 32MM JT GLAZING GASKET   JOINT DE VITRAGE	2L + 8H
208307	PELÚCIA 7x10 TRI-FIN PRETA PILE SEAL   JOINT BROSSSE	4L + 8H
208469	PELÚCIA SRF 4X8 2P1M Preta PILE SEAL   JOINT BROSSSE	4H
208479	JUNTA TAPA CANAL PERFIL LIG. 2117 JT JOINT   JOINT	H

\* Usar em folhas com vidros com peso superior a 80kg  
 To be used in sashes which glass weight exceed 80kg | Utiliser dans des panneaux de verre d'un poids supérieur à 80 kg  
 (a) Conforme esquemas de drenagem (Capítulo V - Maquinações)  
 According to drainage schemes (Chapter V - Machinings) | Selon les schémas de drainage (Chapitre V - Usinages)

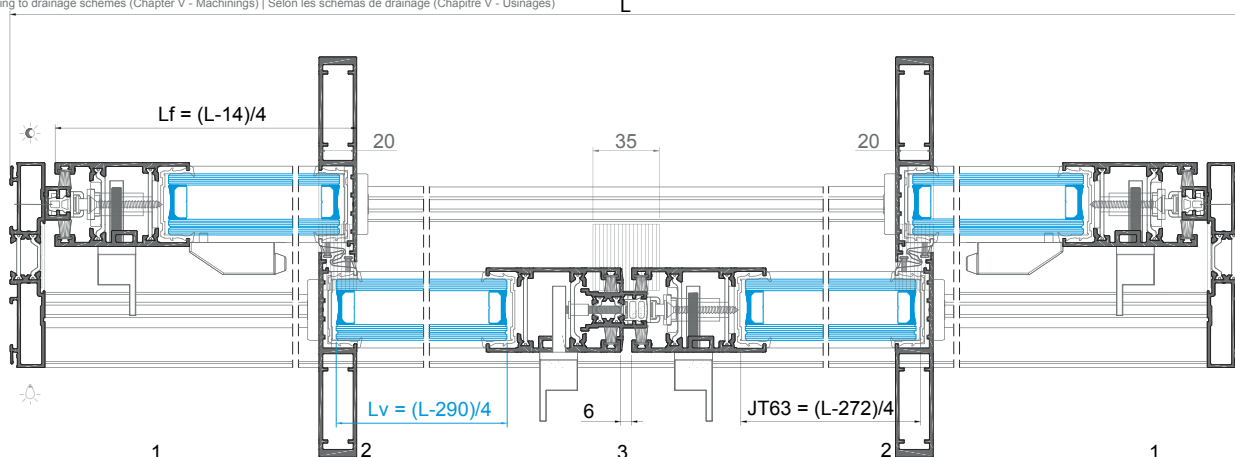

## JANELA DE CORRER 4 FOLHAS JT 2-RAIL CANTO 90° COM PERFIS CENTRAIS 20mm E OMBREIRA JT 18 - LINHA SOLEIRA 30MM

4 JT SASHES 2-RAIL WITH JT18 JAMB SLIDING WINDOW WITH 20mm CENTRAL PROFILES IN 90° CORNER - 30MM SILL LINE

FENÊTRE COULISSANT 4 VANTAUX JT AVEC PROFILÉS CENTRAUX 20mm ET JAMBAGE JT18 À ANGLE 90° - LIGNE SEUIL 30MM

PERFIS   PROFILES   PROFILÉS					
CÓDIGO CODE   CODE	DESIGNAÇÃO DESIGNATION   NOMINATION	CORTE HORIZ. HORIZONTAL CUT CODRE HORIZ.	CORTE VERT. VERTICAL CUT COURE VERTICALE	QUANT. QUANTITY QUANTITE	CORTE CUT COUDE
JT 12	PADIEIRA LINTEL   LINTEAU	L1-19 L2-19	-	1	
JT 18	OMBREIRA JAMB   JAMBAGE	-	H	2	
JT 78	GUIA DA OMBREIRA JAMB GUIDE   GUIDE POUR JAMBAGE	-	H-74	2	
JT 22	SOLEIRA SILL   SEUIL	L1-19 L2-19	-	1	
JT 56	PERFIL CENTRAL CENTRAL PROFILE   PROFILÉ CENTRAL	-	H-59	4	
JT 67	PERFIL LATERAL LATERAL PROFILE   PROFILÉ LATÉRAL	-	H-59	2	
JT 62	PERFIL LIGAÇÃO CANTO 90° CONNECTION PROFILE   PROFILÉ DE LIAISON	-	H-59	2	
JT 63	TRAVESSA SUP/INF UP/LOW TRANSOM   TRAVERSE SUP/INF	(L1-227)/2 (L2-239)/2	-	4 4	
JT 72	PERFIL LIGAÇÃO CENTRAL CONNECTION PROFILE   PROFILÉ DE LIAISON	-	H-128	1	
JT 82	PERFIL PINGADEIRA DRIP PROFILE   L'ARMIER	L1+6 L2+6	-	1 1	
JT 87	GUIA GUIDE   GUIDE	L1-50 L1-93 L2-50 L2-93	-	1 1 1 1	
JE 96	PERFIL POLIAMIDA POLYAMIDE PROFILE   PROFILÉ DE POLYAMIDE	(L1-129)/2 (L1-157)/2 (L2-144)/2 (L2-141)/2	H	1 1 1 1	
208351	JUNTA CENTRAL 2197 CENTRAL JOINT   JOINT CENTRALE	-	H-59	4	
215305	PERFIL PVC U U PVC PROFILE   PROFILÉ PVC U	L1-19 L2-19	-	1 1	

VEDANTES   SEALS   JOINTS		
CÓDIGO CODE   CODE	DESIGNAÇÃO DESIGNATION   NOMINATION	QUANT. QUANTITY QUANTITE
208348	JUNTA TAPA CANAL 2116 JT JOINT   JOINT	2L1 2L2 + 2H
208099	JUNTA VIDRO U 1032 CX 32MM JT GLAZING GASKET   JOINT DE VITRAGE	2L1 + 8H 2L2
208307	PELUCIA 7x10 TRI-FIN PRETA FILE SEAL   JOINT BRUSSE	4L1 + 9H 4L2
208469	PELÚCIA SRF 4X8 2P 1M Preta DIP SEAL   JOINT BRUSSE	4H
208479	JUNTA TAPA CANAL PERFIL LIG. 2117 JT JOINT   JOINT	H
208435	JUNTA VD 2415 JOINT   JOINT	H

As fórmulas foram concebidas para medidas de vidros iguais. Nesta tipologia existem 4 larguras de folha distintas: Lf1, Lf2, Lf3 e Lf4.  
The formulas were designed for glasses with equal measures. In this typology there are 4 distinct sash widths: Lf1, Lf2, Lf3 and Lf4.  
Les formules sont conçues pour mesurer le verre. Dans cette typologie, il existe 4 largeurs de vantaux distinctes: Lf1, Lf2, Lf3 et Lf4.

ACESSÓRIOS   ACCESSORIES   ACCESSOIRES		
CÓDIGO CODE   CODE	DESIGNAÇÃO DESIGNATION   NOMINATION	QUANT. QUANTITY QUANTITE
205129	CARRINHO JT 180KG ROLLER   ROULETTE	8
213402	CORTA-VENTO JT-SLIM CENTRAL WATERPROOFING BRUSH   BRUSSE CENTRALE D'ÉTANCHÉITÉ	2
213288	CORTA-VENTO BAIXO JT LOW CENTRAL WATERPROOFING BRUSH   BRUSSE CENTRALE D'ÉTANCHÉITÉ BAS	5
213287	CORTA-VENTO CANTO 90° JT 90° CORNER WATERPROOFING BRUSH   BRUSSE D'ÉTANCHÉITÉ ANGLE 90°	1
223105	KIT JUNTAS ADESIVAS Nº1 JT JT Nº1 ADHESIVE JOINTS KIT   KIT DE JOINTS ADHÉSIFS Nº1 JT	1
212243	CONJ. UNIÃO CANTO 90° JT 90° CORNER UNION KIT   KIT D'UNION ANGLE 90°	1
212109	CONJ. UNIÃO CANTO 90° ARO BAIXO JT 90° CORNER LOW FRAME UNION KIT   KIT D'UNION ANGLE 90° POUR CADRE BAS	1
204389	ESQUADRO INOX CANTO 90° 90° STAINLESS STEEL CORNER   ANGLE EN ACIER INOXYDABLE 90°	1
212199	CONJ. TOPOS LAT. JT LATERAL END-CAPS KIT   KIT D'EMBOUS LATÉRAUX	4
212230	CONJ. TOPOS INTERIOR LAT. JT LATERAL INNER END-CAPS KIT   KIT D'EMBOUS INTÉRIEUR LATÉRAUX	3
212201	CONJ. TAMPAS TOPOS LAT. JT LATERAL END-CAP COVERS KIT   KIT DE COUVERTURE POUR EMBOUTS LATÉRAUX	3
212273	CONJ. TOPOS CENTRAIS N.1 20MM JT N.1 20MM CENTRAL END-CAPS KIT   KIT D'EMBOUS CENTRAUX N.1 20MM JT	4
212252	CONJ. TOPOS INTERIORES LAT./CENTR. JT-SLIM LAT/CENT. INNER END-CAP COVERS KIT   KIT DE COUVERT. POUR EMBOUTS LAT/CENTR. INTÉR.	4
212335	CONJ. TAMPAS TOPOS CENTRAIS JT-SLIM CENTRAL END-CAP COVERS KIT   KIT DE COUVERTURE POUR EMBOUTS CENTRAUX	4
210231	TOPO CENTRAL REFORÇADO JT56 28MM 38MM CENTRAL REINFORCED END-CAPS KIT   KIT D'EMBOUS CENTRAUX RENFORCÉ 28MM	8
212109	CONJ. TOPOS CANTO 90° JT 90° CORNER END-CAPS KIT   KIT D'EMBOUS POUR ANGLE 90°	1
210268	GOTEIRA C/ VALV. SVE OUTSIDE FLAP VALVE   CLAPE À VOLET EXTÉRIEUR	(a)
211223	FERRAGEM MULTIPONTO CENTR. 1000 MULTIPOINT HARDWARE   SERRURE MULTIPONT	3
202491	CONTRA-FECHO ANTI-LEVANTAMENTO MULTIPONTO STRIKING PLATE   GÂCHE	6
202487	CENTRADOR JT P/ C-FECHO AL MULTIPONTO JT CENTERING FOR STRIKING PLATE   CENTRAGE JT POUR GÂCHE	4
212455	CONJ. FIX. CONTRA-FECHO AL MULTIP. JT MULTIPOINT HARDWARE STRIKING PLATE FIXING KIT   KIT FIXATION GÂCHE SERRURE MULTIPONT	4
212458	CONJ. FIX. CONTRA-FECHO MULTIP. 2F/90° JT MULTIPOINT HARDWARE STRIKING PLATE FIXING KIT   KIT FIXATION GÂCHE SERRURE MULTIP.	2
218154	CALÇO P/ C-FECHO PERF. LIG CONNECTING PROFILE STRIKING PLATE SHIM   CALE POUR GÂCHE PROFILÉ DE LIAISON	2
218149	CALÇO Nº2 P/ MULTIPONTO SOS JT MULTIPOINT HARDWARE SHIM   CALE POUR MULTIPONT	18
212161	CONJ. CENTRADOR P/ FERRAGEM JT CENTERING KIT FOR JT HARDWARE   KIT CENTRAGE POUR SERRURE JT	2
212162	CONJ. CENTRADOR P/ FERRAGEM JT PERFIL LIG CENTERING KIT FOR HARDWARE   KIT CENTRAGE POUR SERRURE JT	1
212371	CONJ. FIXAÇÃO JT FIXING KIT   KIT FIXATION	18
212079	CONJ. FIX. FERRAGEM MULTIP. JT72 MULTIPOINT FIXING KIT   KIT FIXATION SERRURE MULTIPONT	1 + 1 un./m (min. 4)
200819	PUXADOR SLIM XS - ESQUERDO LEFT HANDLE   POIGNÉE GAUCHE	1
200817	PUXADOR SLIM XS - DIREITO RIGHT HANDLE   POIGNÉE DROITE	2
212384	CONJ. TOPOS LAT. PINGADEIRA JT82 LATERAL DRIP END-CAPS KIT   KIT D'EMBOUS LATÉRAUX POUR REJET D'EAU	1
228107	LIMITADOR ABERT. PQ SERIE CORRER OPENING LIMITER   LIMITEUR D'OUVERTURE	2
290052	PARAF DIN7982 PH 3,5x16 A2 SCREW   VIS	1 + 4 un./m
290262	PARAFUSO PK INOX PH 1 1/2x10 CQ SCREW   VIS	32
290030	PARAFUSO DIN7981 4,2x38 INOX A2 SCREW   VIS	8
218137	CALÇO REFORÇO HORIZONTAL JT * HORIZONTAL REINFORCEMENT SHIM   CALE DE RENFORCEMENT HORIZONTALE	8

\* Usar em folhas com vidros com peso superior a 80kg  
To be used in sashes which glass weight exceed 80kg | Utiliser dans des panneaux de verre d'un poids supérieur à 80 kg

(a) Conforme esquemas de drenagem (Capítulo V - Maquinações)

According to drainage schemes (Chapter V - Machinings)

Selon les schémas de drainage (Chapitre V - Usinages)

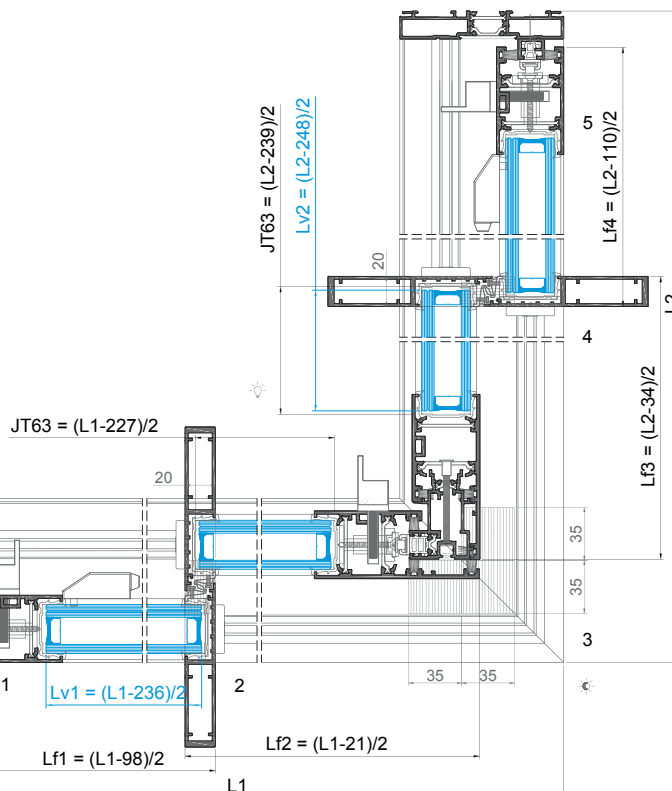
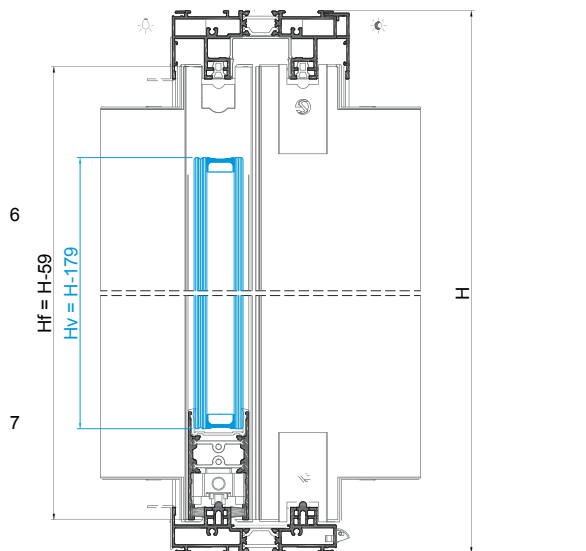
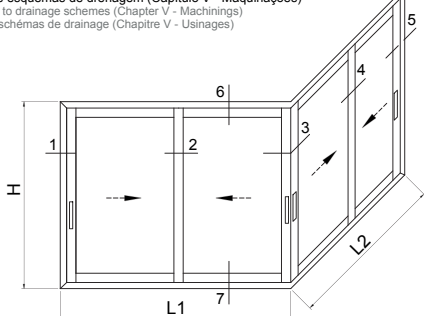



# V

## MAQUINAÇÕES DOS PERFIS PROFILES MACHININGS | USINAGES DES PROFILÉS

MAQUINAÇÕES NOS CORTANTES PUNCHING TOOLS MACHININGS OPÉRATIONS D'USINAGE POUR OUTILS	V.1
MAQUINAÇÃO DOS PERFIS ARO FIXO FR, PT E TIPOLOGIAS FIXAS (CORTE 45°) FR, PT AND FIXED TYPOLOGIES FIXED FRAME PROFILES MACHINING (45° CUT) USINAGE DES PROFILÉS DORMANT FR, PT E TIPOLOGIAS FIXES (COUPE 45°)	V.2
MAQUINAÇÃO DOS PERFIS ARO FIXO PARA APLICAÇÃO COM SOLEIRA 30MM (CORTE 90°) FIXED FRAME PROFILES MACHINING FOR APPLICATION WITH 30MM SILL PROFILE (90° CUT) USINAGE DES PROFILÉS DORMANT POUR APPLICATION DE SEUIL 30MM (COUPE 90°)	V.3
MAQUINAÇÃO DOS PERFIS ARO FIXO PT (CORTE 45°) PARA APLICAÇÃO COM SOLEIRA 30MM (CORTE 90°) PT FIXED FRAME PROFILES MACHINING (45° CUT) FOR APPLICATION WITH 30MM SILL PROFILE (90° CUT) USINAGE DES PROFILÉS DORMANT PT (COUPE 45°) POUR APPLICATION DE SEUIL 30MM (COUPE 90°)	V.4
MAQUINAÇÃO DOS PERFIS DE CAPA COVER PROFILES MACHINING USINAGE DES PROFILÉS DE CAPOT	V.5
MAQUINAÇÃO DOS PERFIS MONTANTES MULLION PROFILES MACHINING USINAGE DES PROFILÉS MENEAX	V.6
MAQUINAÇÃO DOS PERFIS GUIA E VEDANTE TAPA CANAL 2116 GUIDE PROFILE AND 2116 CHANNEL COVER JOINT MACHINING USINAGE DU PROFILÉ GUIDE ET DE LA JOINT DE COUVERTURE DU CHANNEL 2116	V.7
DRENAGENS POR TIPOLOGIA DRAINAGE BY FRAME TYPOLOGY DRAINAGE PAR TYPOLOGIE	V.8
MAQUINAÇÕES DOS PERFIS ARO MÓVEL JT JT MOBILE FRAME PROFILES MACHINING USINAGE DES PROFILÉS OUVRANT JT	V.9
MAQUINAÇÕES DOS PERFIS ARO MÓVEL JT-SLIM JT-SLIM MOBILE FRAME PROFILES MACHINING USINAGE DES PROFILÉS OUVRANT JT-SLIM	V.10

**MAQUINAÇÕES NOS CORTANTES**  
PUNCHING TOOLS MACHININGS  
OPÉRATIONS D'USINAGE POUR OUTILS

1 - Cortante para aros fixos FR.  
FR fixed frames punching tool.  
Outil pour dormant FR.

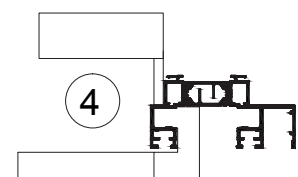
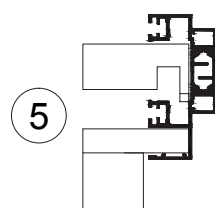
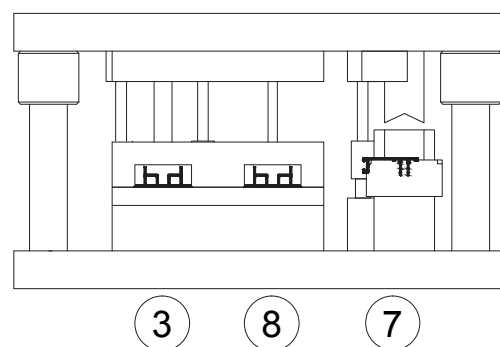
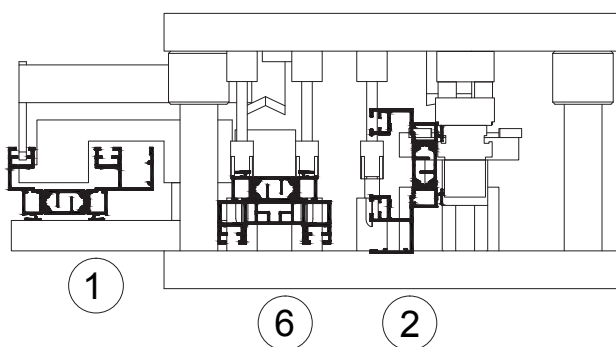
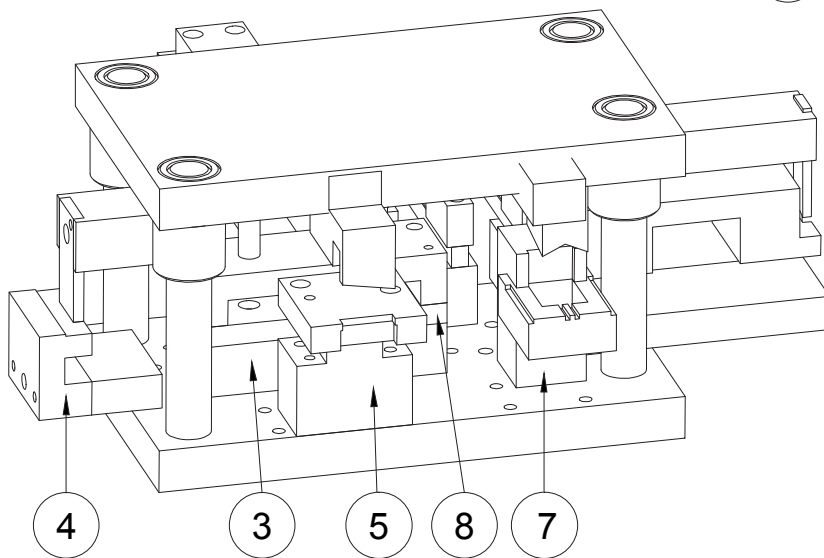
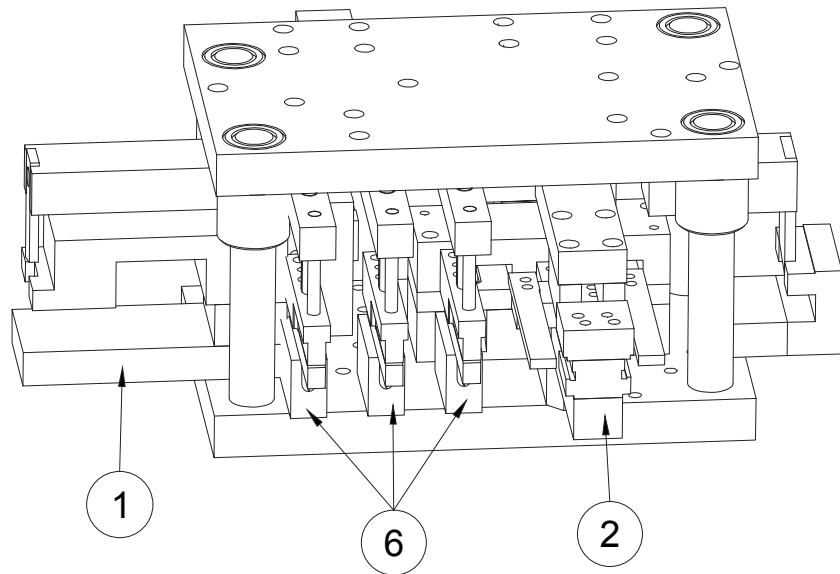

**MAQUINAÇÕES NOS CORTANTES**  
PUNCHING TOOLS MACHININGS  
OPÉRATIONS D'USINAGE POUR OUTILS

**1 - Cortante para aros fixos FR.**  
FR fixed frames punching tool.  
Outil pour dormant FR.

**1 - Saída de águas**  
Water drainage | Sortie des eaux

Rasgo | Hole | Rainure R3: 5x20mm

**3 - Saída de águas**  
Water drainage | Sortie des eaux

Furo | Hole | Trou R6: Ø12mm

**4 - Saída de águas**  
Water drainage | Sortie des eaux

Rasgo | Hole | Rainure R4: 6x35mm

**5 - Saída de águas**  
Water drainage | Sortie des eaux

Rasgo | Hole | Rainure R2: 6x35mm  
Rasgo | Hole | Rainure R5: 6x35mm

**7 - Rasgo para perfis capa**  
Cover profiles milling | Rainure pour profilés de capot

Perfis | Profiles | Profilés JT85 e | and | et JT 88

**8 - Saída de águas**  
Water drainage | Sortie des eaux

Rasgo | Hole | Rainure R1: 6x30mm

**2 - Corte da aba do perfil nas esquadrias**  
Profiles milling | Coupe du rabat du profilé sur les cadres

**6 - Furação para esquadros**  
Corner cleat drilling | Perçage pour équerres

JT 01      JT 02

JT 04      JT 03

**MAQUINAÇÕES NOS CORTANTES**  
PUNCHING TOOLS MACHININGS  
OPÉRATIONS D'USINAGE POUR OUTILS

2 - Cortante para perfis aros fixos das tipologias PT, soleira 30mm e fixas.  
PT, 30mm sill and fixed typologies fixed frame profiles Punching Tool.  
Outil pour profilés dormants de typologies PT, seuil 30mm et fixes.

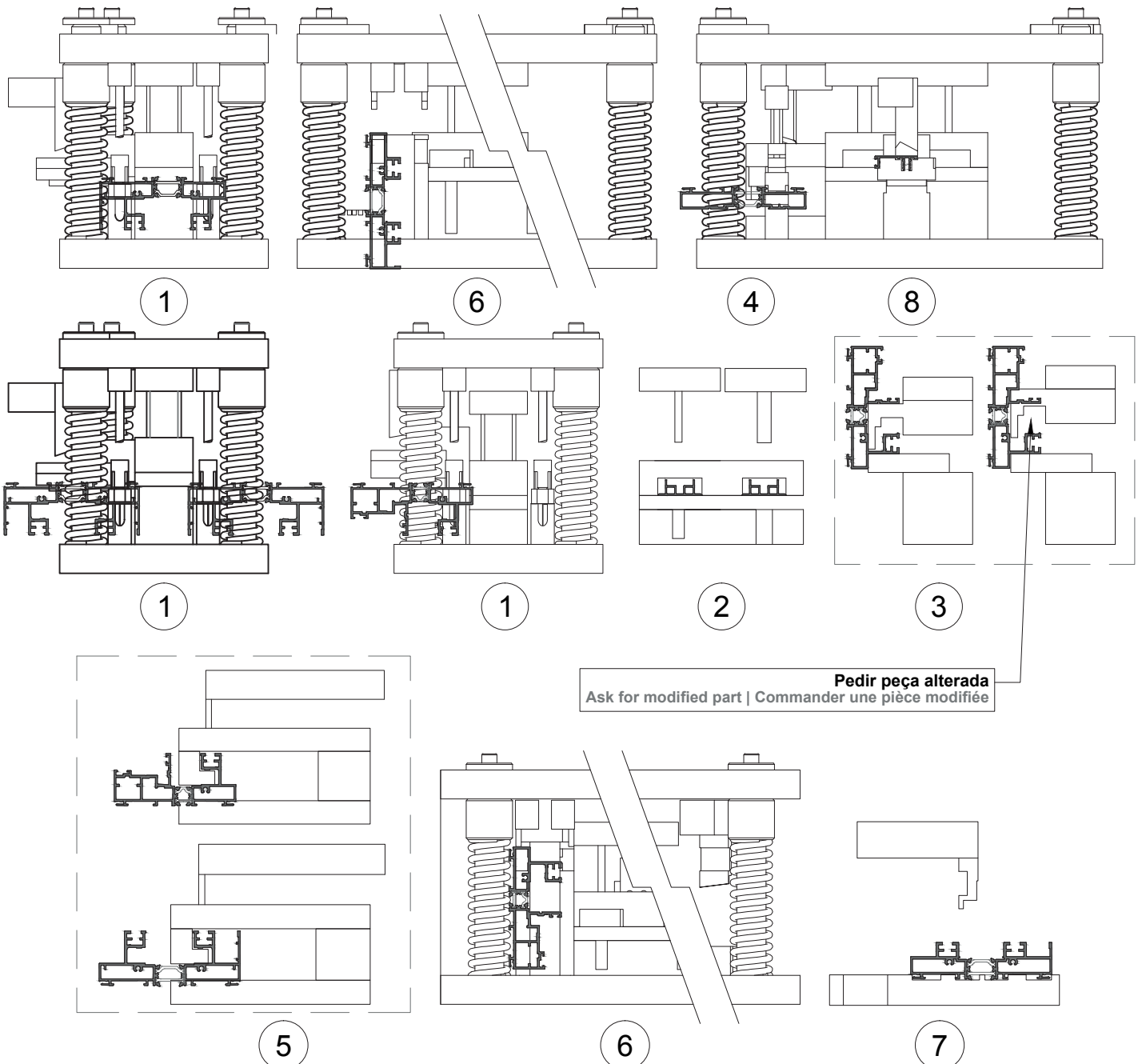
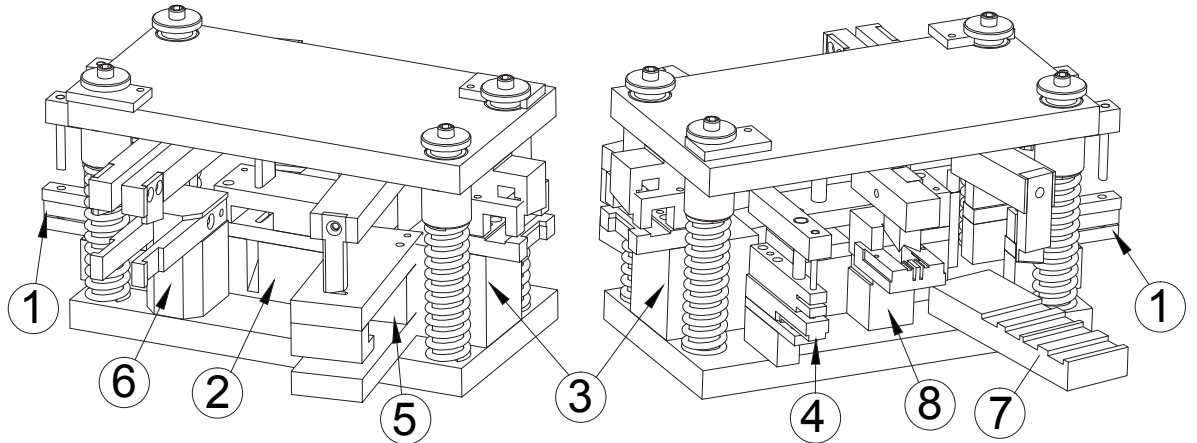

**MAQUINAÇÕES NOS CORTANTES**  
PUNCHING TOOLS MACHININGS  
OPÉRATIONS D'USINAGE POUR OUTILS

**2 - Cortante para perfis aros fixos das tipologias PT, soleira 30mm e fixas.**  
PT, 30mm sill and fixed typologies fixed frame profiles Punching Tool.  
Outil pour profilés dormants de typologies PT, seuil 30mm et fixes.

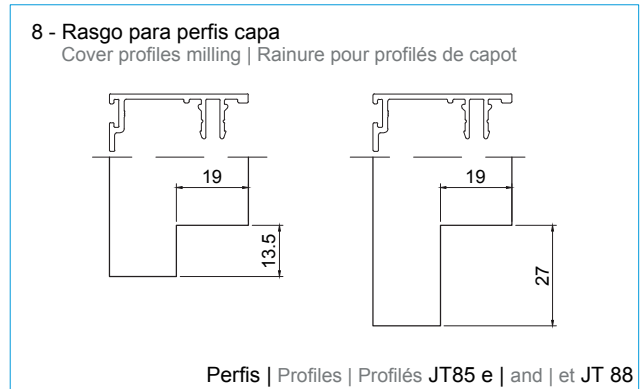
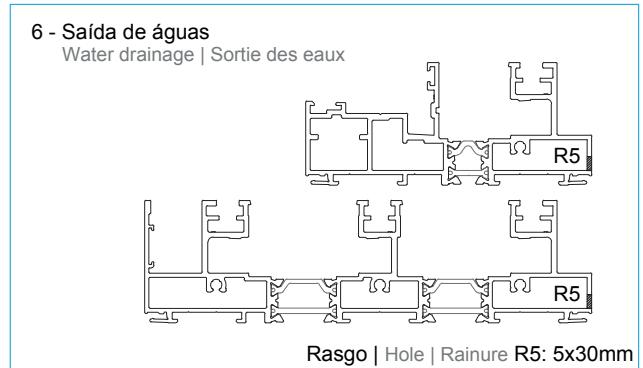
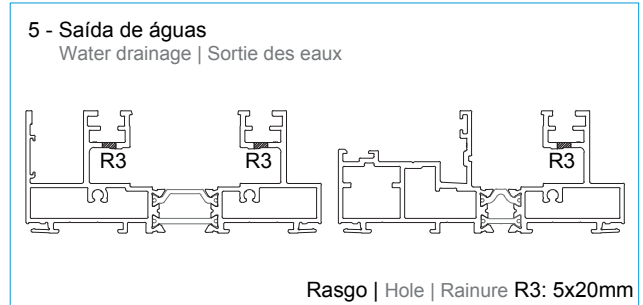
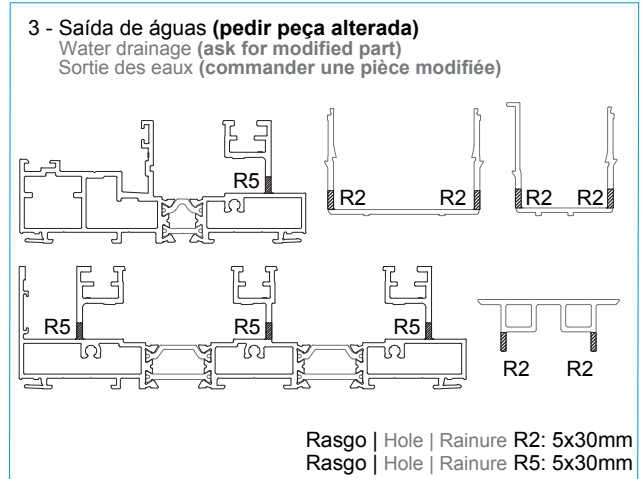
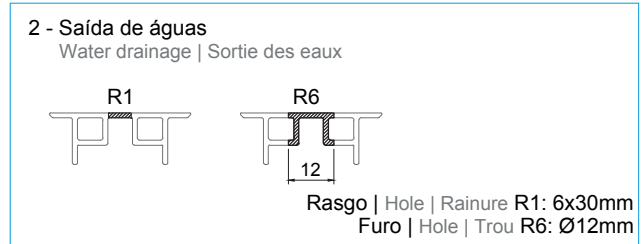
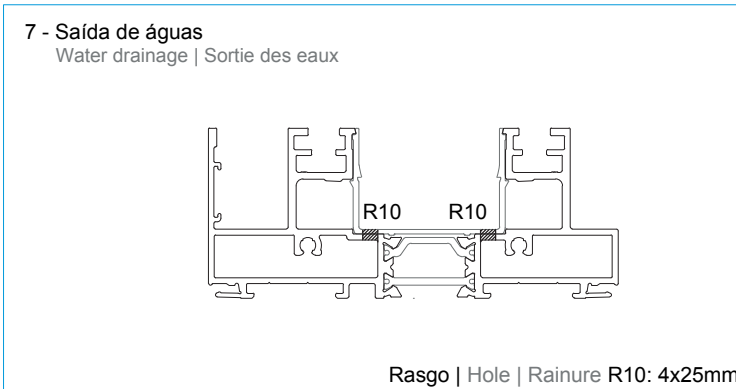
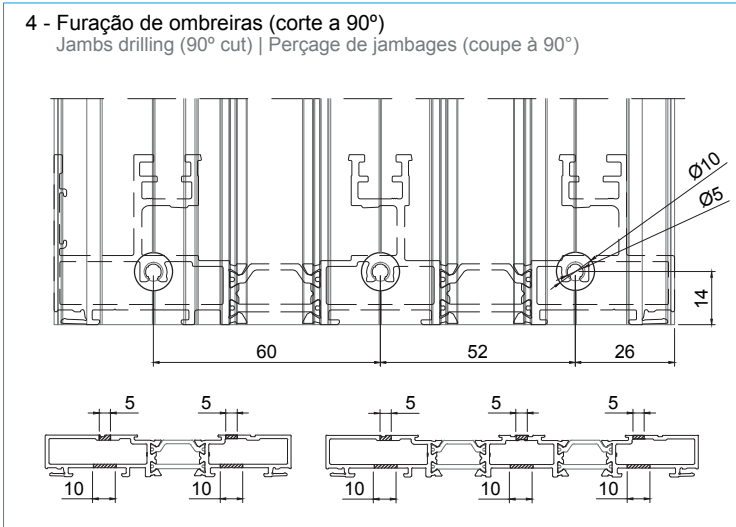
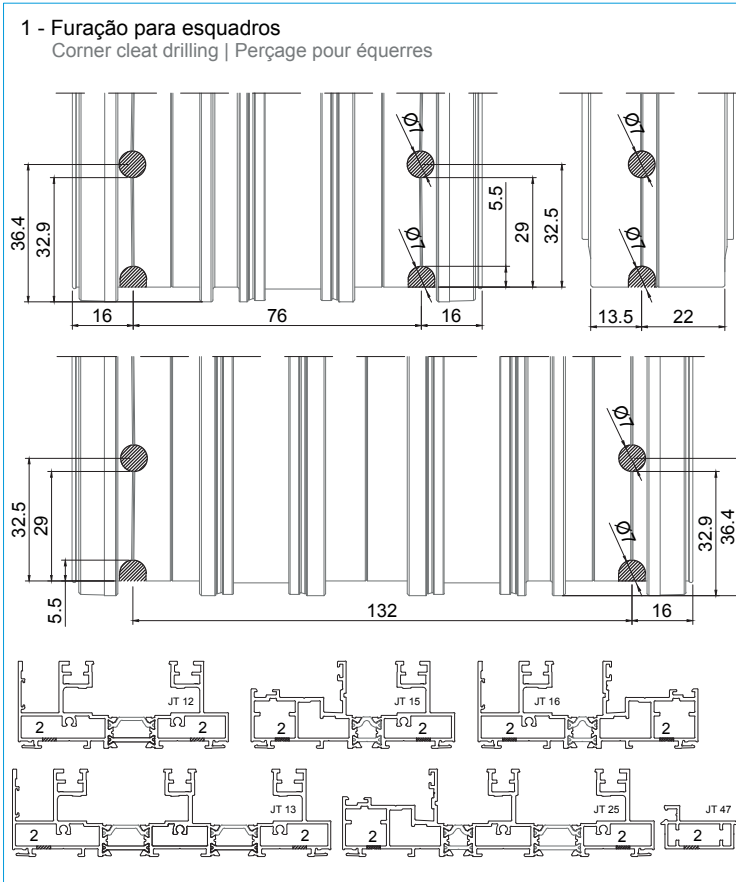

**MAQUINAÇÕES NOS CORTANTES**  
PUNCHING TOOLS MACHININGS  
OPÉRATIONS D'USINAGE POUR OUTILS

**3 - Cortante para folhas JT.**  
JT Mobile frames punching tool.  
Outil pour cadres ouvrants JT.

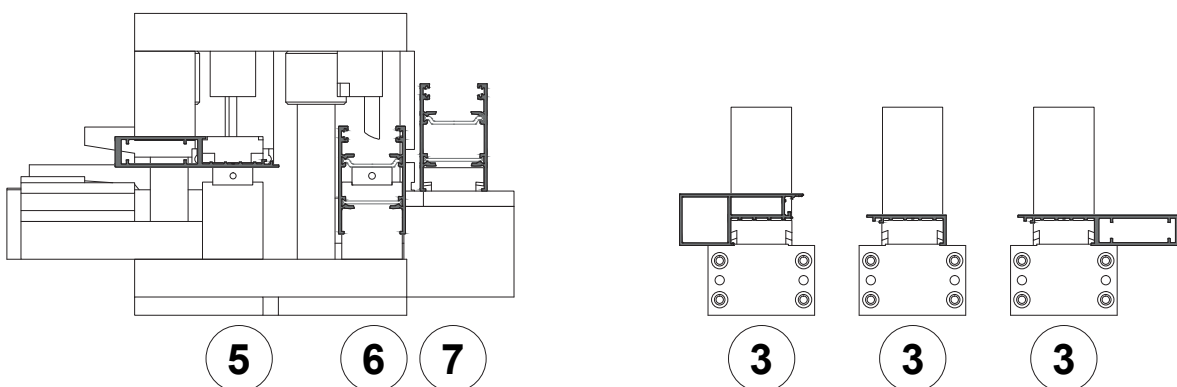
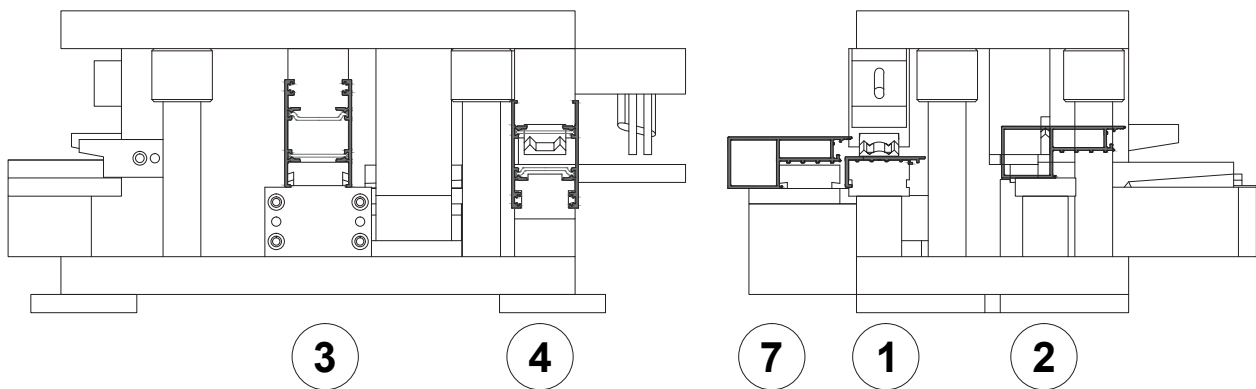
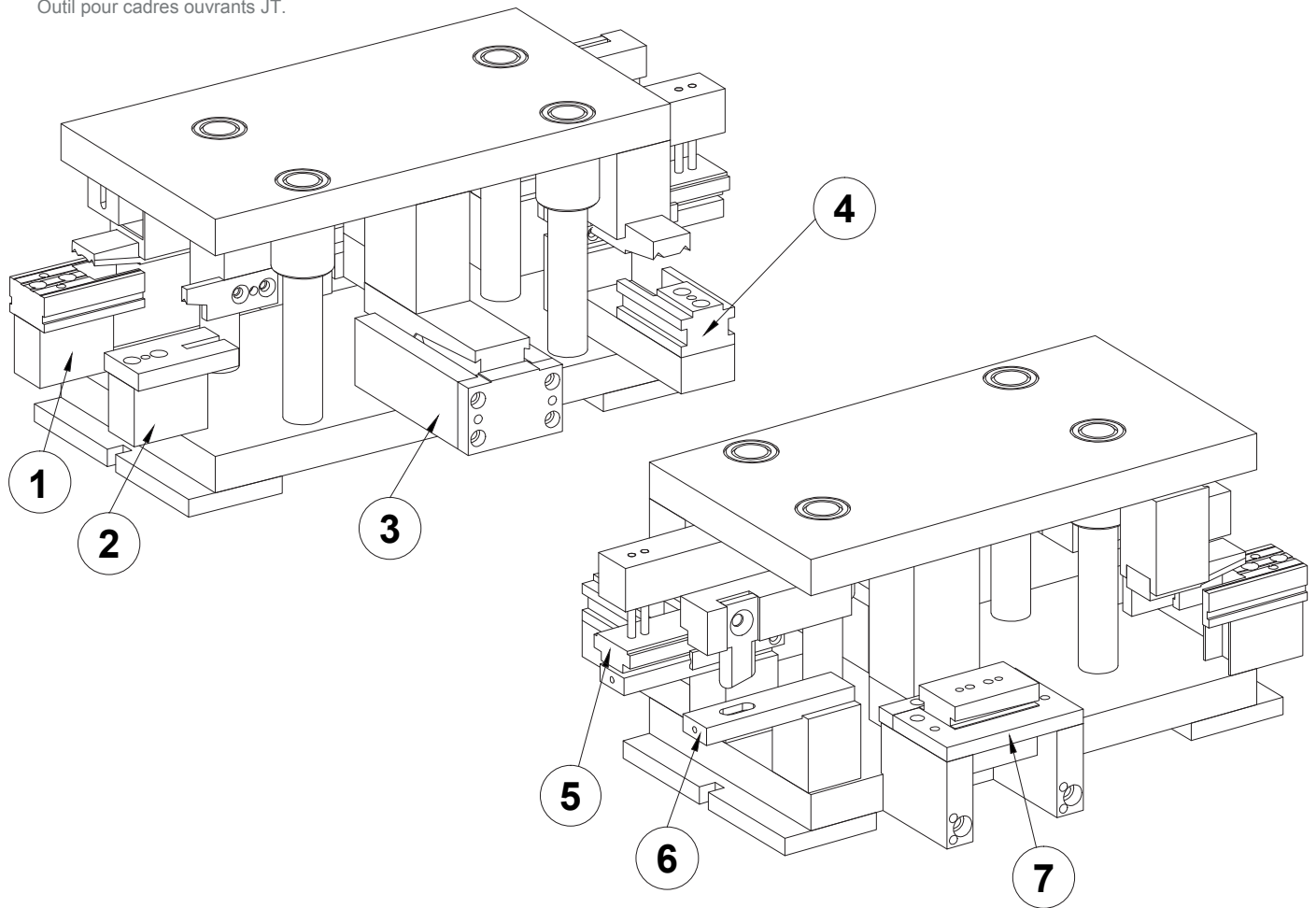



**MAQUINAÇÕES NOS CORTANTES**  
PUNCHING TOOLS MACHININGS  
OPÉRATIONS D'USINAGE POUR OUTILS

**3 - Cortante para folhas JT.**  
JT Mobile frames punching tool.  
Outil pour cadres ouvrants JT.

**1 - Entalhe para topo central**  
Central end-cap milling | Fraisage pour embout central

Perfis centrais  
Central profiles  
Profils centraux  
JT51 | JT52 | JT53 | JT54 | JT55 | JT56

**2 - Fresagem no tubular de reforço**  
Reinforcement tubular milling | Fraisage dans le tubulaire de renfort

Perfis centrais  
Central profiles  
Profils centraux  
JT52 | JT53 | JT54 | JT56

**3 - Maquinação para travessa**  
Machining for transom | Usinage pour traverse

Perfis laterais e centrais  
Lateral and central profiles | Profils latéraux et centraux  
JT51 | JT52 | JT53 | JT54 | JT55 | JT56  
JT61 | JT62 | JT64 | JT65 | JT66 | JT67 | JT68

**4 - Entalhe para topo lateral**  
Lateral end-cap milling | Fraisage pour embout latéral

Perfis laterais  
Lateral profiles  
Profils latéraux  
JT61 | JT62 | JT64 | JT65 | JT66 | JT67 | JT68

**5 - Furação para topo lateral**  
Lateral end-cap drilling | Perçage pour embout latéral

Perfis laterais  
Lateral profiles  
Profils latéraux  
JT61 | JT62 | JT64 | JT65 | JT66 | JT67 | JT68

**6 - Entalhe para topo lateral**  
Lateral end-cap milling | Fraisage pour embout latéral

Perfis laterais e centrais  
Lateral and central profiles | Profils latéraux et centraux  
JT51 | JT52 | JT53 | JT54 | JT55 | JT56  
JT61 | JT62 | JT64 | JT65 | JT66 | JT67 | JT68

**7 - Maquinação para travessa**  
Machining for transom | Usinage pour traverse

Perfis laterais e centrais  
Lateral and central profiles | Profils latéraux et centraux  
JT51 | JT52 | JT53 | JT54 | JT55 | JT56  
JT61 | JT62 | JT64 | JT65 | JT66 | JT67 | JT68

**MAQUINAÇÕES NOS CORTANTES**  
PUNCHING TOOLS MACHININGS  
OPÉRATIONS D'USINAGE POUR OUTILS

**4 - Cortante para folhas JT-Slim.**  
JT-Slim Mobile frames punching tool.  
Outil pour cadres ouvrants JT-Slim.

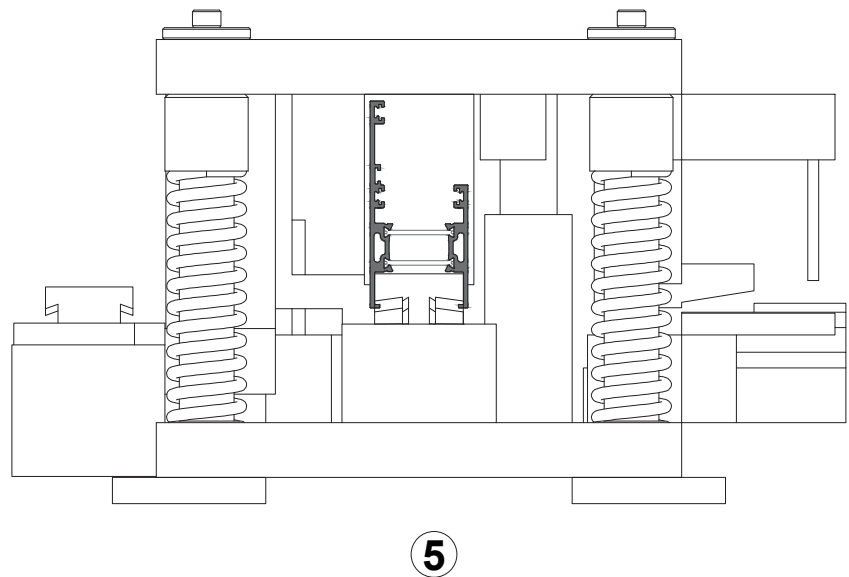
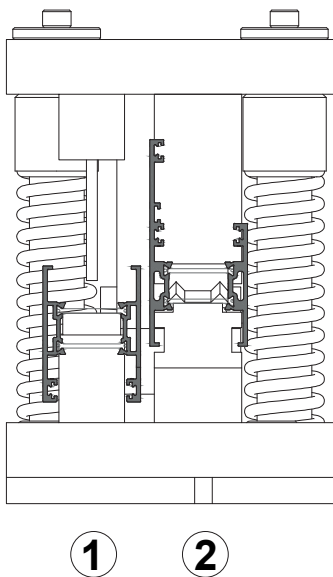
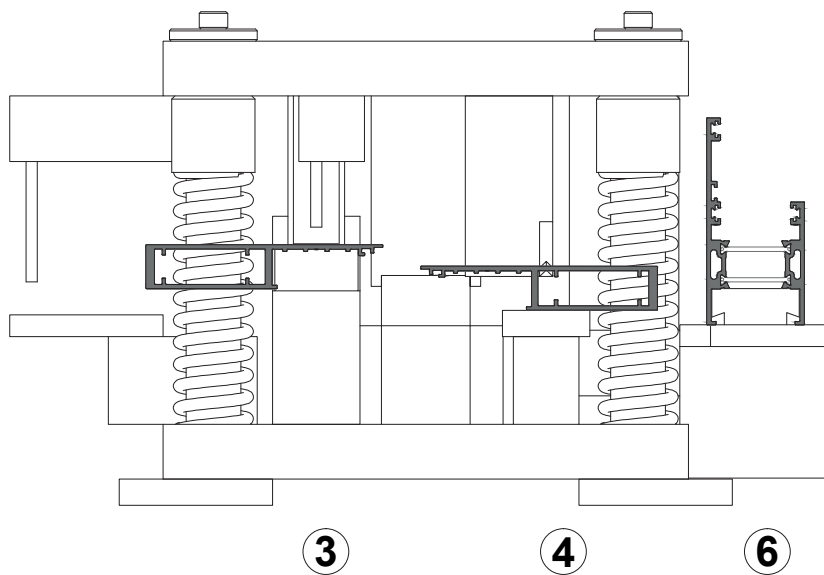
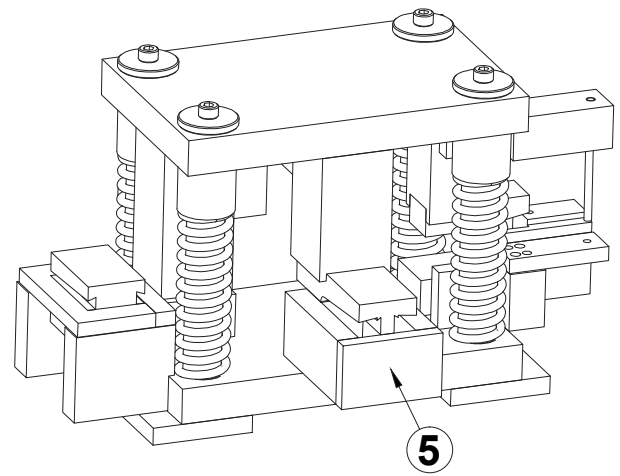
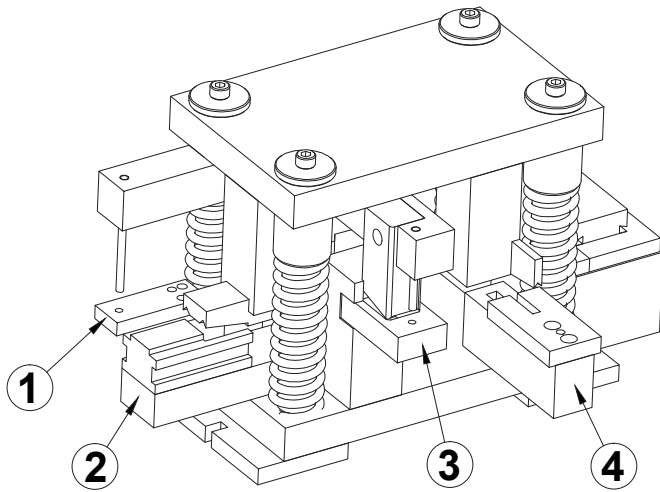

**MAQUINAÇÕES NOS CORTANTES**  
PUNCHING TOOLS MACHININGS  
OPÉRATIONS D'USINAGE POUR OUTILS

**4 - Cortante para folhas JT-Slim.**

JT-Slim Mobile frames punching tool.  
Outil pour cadres ouvrants JT-Slim.

**1 - Furo para topo lateral**

Lateral end-cap drill | Perçage pour embout latéral

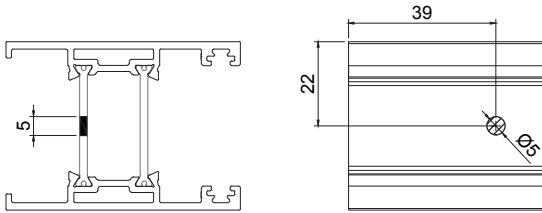

**Perfis lateral e de ligação**  
Lateral and connection profiles  
Profils latéral e de connexion  
JT60 | JT70

**2 - Entalhe para topo lateral**

Lateral end-cap milling | Fraisage pour embout latéral

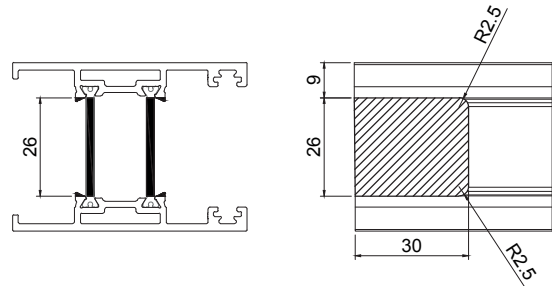

**Perfis lateral e de ligação**  
Lateral and connection profiles  
Profils latéral e de connexion  
JT60 | JT70

**3 - Entalhe para topo central**

Central end-cap milling | Fraisage pour embout central

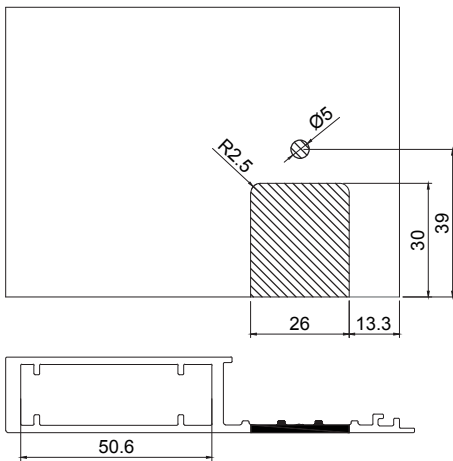

**Perfis centrais**  
Central profiles  
Profils centraux  
JT55 | JT56

**4 - Fresagem no tubular de reforço**

Reinforcement tubular milling | Fraisage dans le tubulaire de renfort

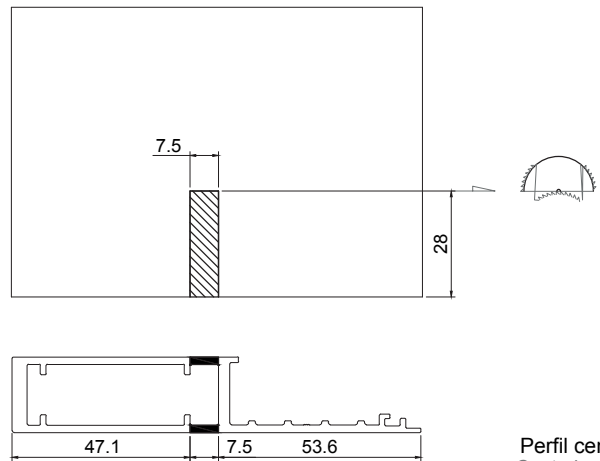

**Perfil central**  
Central profile  
Profilé central  
JT 56

**5 - Maquinação para travessa**

Machining for transom | Usinage pour traverse

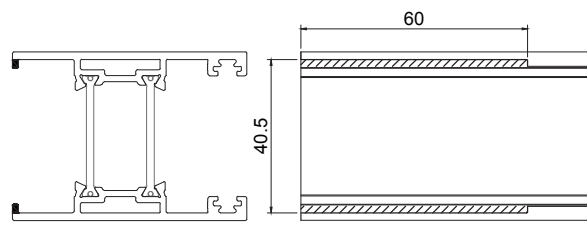
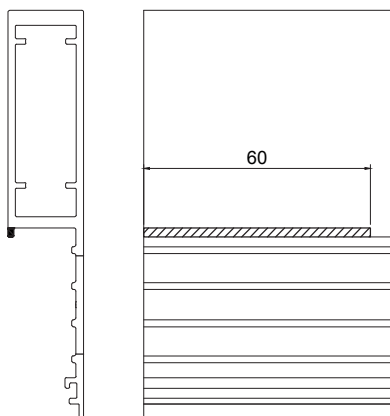

**Perfis laterais, centrais e de ligação**  
Lateral, central and connection profiles  
Profils latéraux, centraux et de connexion  
JT55 | JT56 | JT60 | JT70

**MAQUINAÇÃO DOS PERFIS ARO FIXO FR, PT E TIPOLOGIAS FIXAS (CORTE 45°)**

FR, PT AND FIXED TYPOLOGIES FIXED FRAME PROFILES MACHINING (45° CUT)

USINAGE DES PROFILÉS DORMANT FR, PT E TIPOLOGIAS FIXES (COUPE 45°)

1 - Corte dos perfis para os aros fixos e do perfil PVC U.

Fixed frame profiles and U PVC profile cutting.

Découpe des profilés pour dormants et profilé PVC U.

PASSO | STEP | ÉTAPE 1:

Cortar os perfis para o aro fixo e o perfil PVC U em simultâneo em barras de 6,5m.

Cut the fixed frame profiles and U PVC profile simultaneously in 6,5m bars.

Découper simultanément les profilés pour le dormant et le profilé PVC U en barres de 6,5m.

PASSO | STEP | ÉTAPE 2:

Separar o perfil PVC U antes de prosseguir para a realização das operações no aro fixo.

Separate the U PVC profile before proceeding to carry out operations on the fixed frame.

Séparer le profilé PVC U avant de procéder aux opérations sur le dormant.

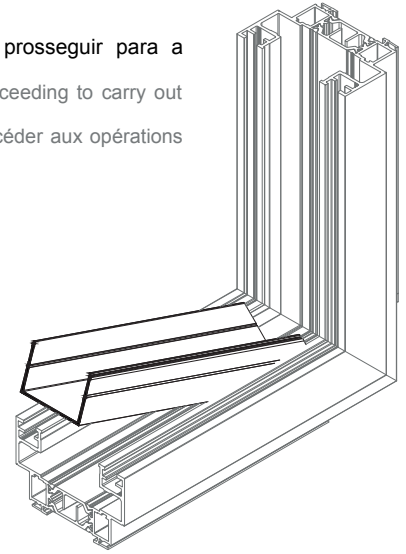
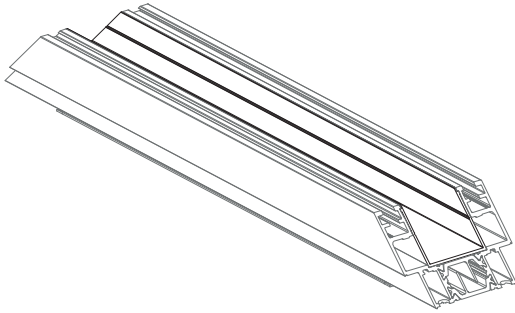

2 - Maquinação dos perfis de aro fixo FR. Seguir este procedimento em todos os perfis de aro fixo FR.

FR fixed frame profiles machining. Follow this procedure in all FR fixed frame profiles.

Usinage des profilés dormant. Suivre cette procédure sur tous les profilés dormant FR.

**IMPORTANTE | IMPORTANT | IMPORTANT:**

Esta maquinação não é necessária nos aros fixos PT.

This machining is not necessary in PT fixed frames.

Cet usinage n'est pas nécessaire pour les dormant PT.

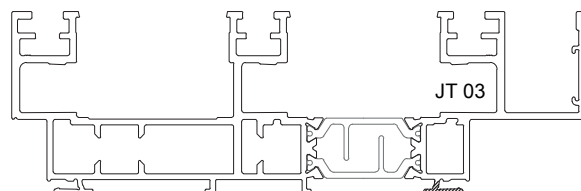
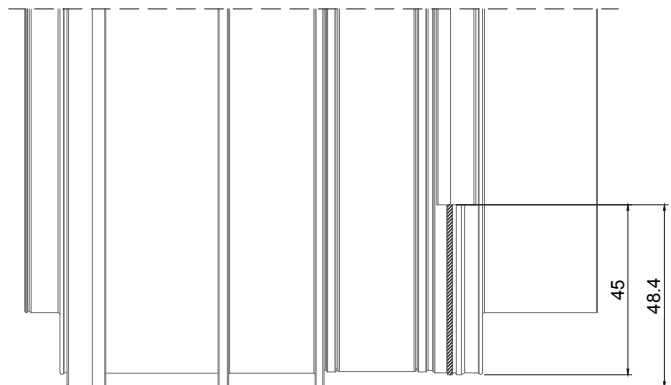
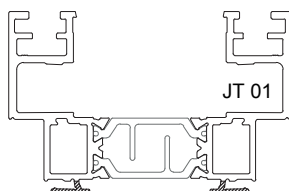
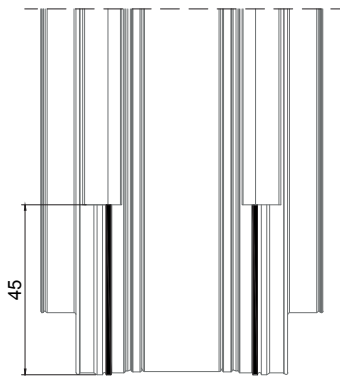
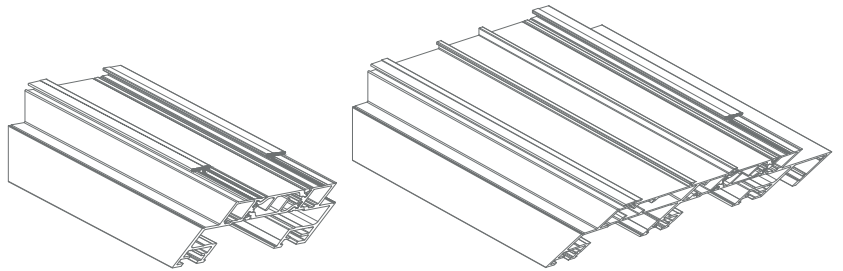
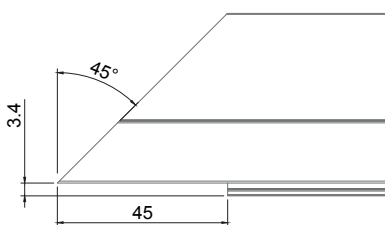

**MAQUINAÇÃO DOS PERFIS ARO FIXO FR, PT E TIPOLOGIAS FIXAS (CORTE 45°)**

FR, PT AND FIXED TYPOLOGIES FIXED FRAME PROFILES MACHINING (45° CUT)

USINAGE DES PROFILÉS DORMANT FR, PT E TIPOLOGIAS FIXES (COUPE 45°)

**3 - Maquinação de perfis aro fixo FR para aplicação de esquadros. Seguir este procedimento em todos os perfis de aro fixo FR.**

FR fixed frame profiles milling for corner cleat application. Follow this procedure in all FR fixed frame profiles.

Fraisage des profilés dormant FR pour l'application de équerres. Suivre cette procédure sur tous les profilés dormant FR.

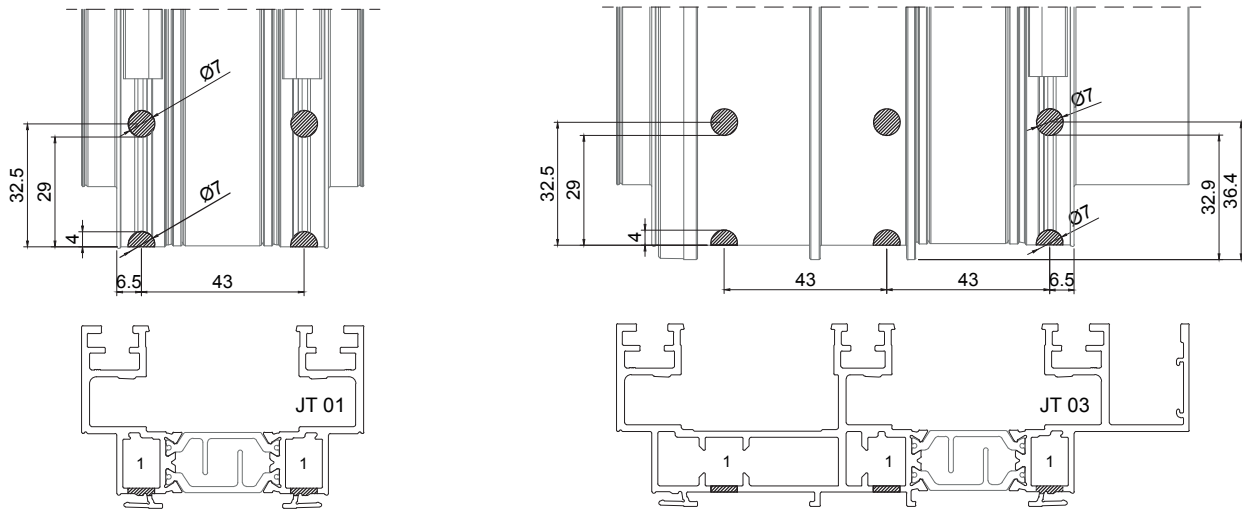

**4 - Maquinação de perfis aro fixo PT para aplicação de esquadros. Seguir este procedimento em todos os perfis de aro fixo PT.**

PT fixed frame profiles milling for corner cleat application. Follow this procedure in all PT fixed frame profiles.

Fraisage des profilés dormant PT pour l'application de équerres. Suivre cette procédure sur tous les profilés dormant PT.

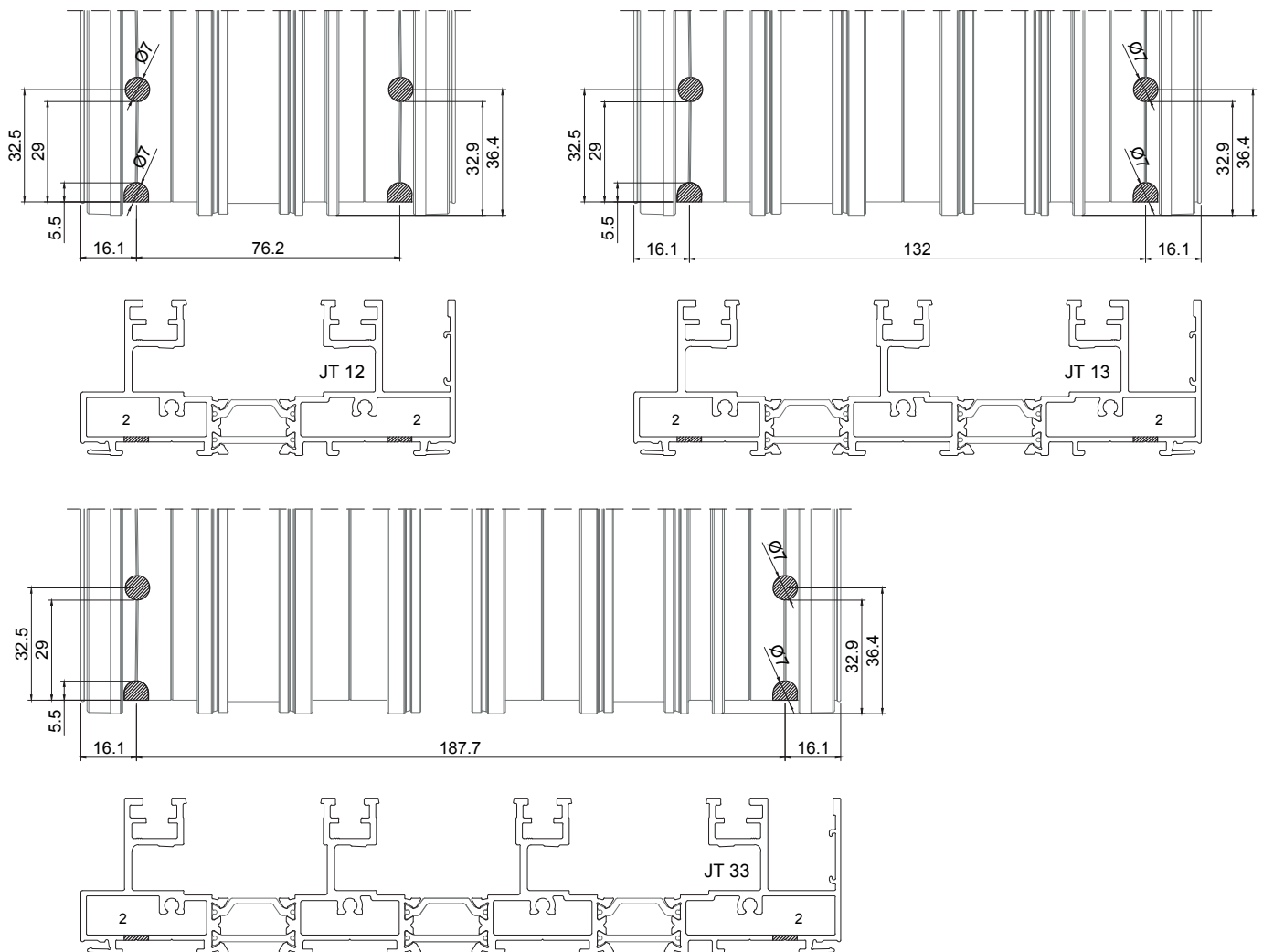

1 - ESQUADRO | CORNER CLEAT | ÉQUERRE JT 12x9.5

2 - ESQUADRO | CORNER CLEAT | ÉQUERRE JT 11x20.5

**MAQUINAÇÃO DOS PERFIS ARO FIXO FR, PT E TIPOLOGIAS FIXAS (CORTE 45°)**

FR, PT AND FIXED TYPOLOGIES FIXED FRAME PROFILES MACHINING (45° CUT)

USINAGE DES PROFILÉS DORMANT FR, PT E TIPOLOGIAS FIXES (COUPE 45°)

**5 - Maquinação dos perfis aro fixo JT 15 e JT 25 para aplicação de esquadros.**

JT 15 and JT 25 fixed frame profiles milling for corner cleat application.

Fraisage des profilés dormant JT 15 et JT 25 pour l'application des équerres.

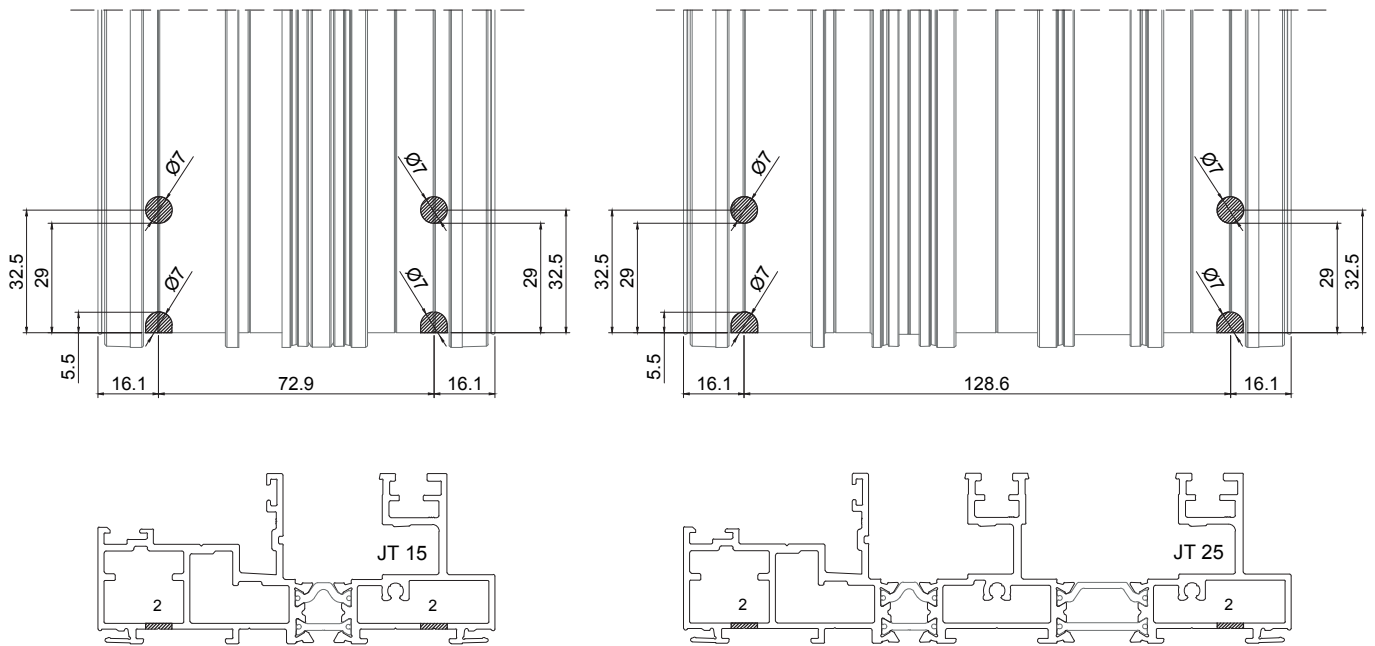

**6 - Maquinação do perfil aro fixo JT 16 para aplicação de esquadros.**

JT 16 fixed frame profile milling for corner cleat application.

Fraisage du profilé dormant JT 16 pour l'application des équerres.

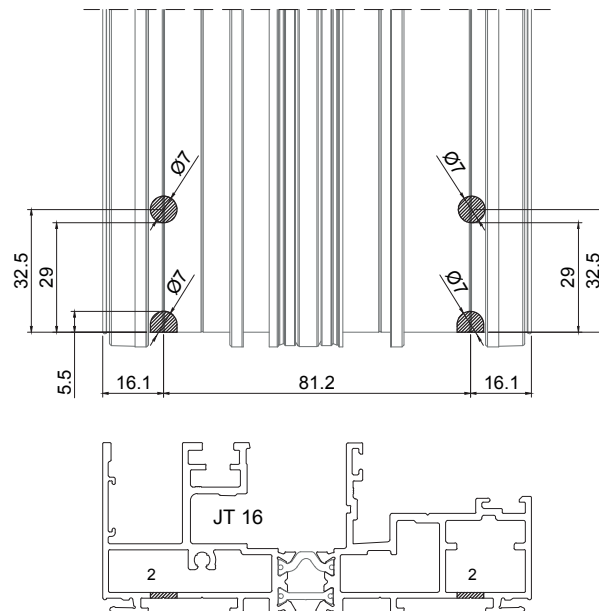



**MAQUINAÇÃO DOS PERFIS ARO FIXO PARA APLICAÇÃO COM SOLEIRA 30MM (CORTE 90°)**  
FIXED FRAME PROFILES MACHINING FOR APPLICATION WITH 30MM SILL PROFILE (90° CUT)  
USINAGE DES PROFILÉS DORMANT POUR APPLICATION DE SEUIL 30MM (COUPE 90°)

1 - Furação dos perfis ombreira.  
Jamb profiles drilling.  
Perçage des profilés de jambage.

JT17 | JT18 | JT19

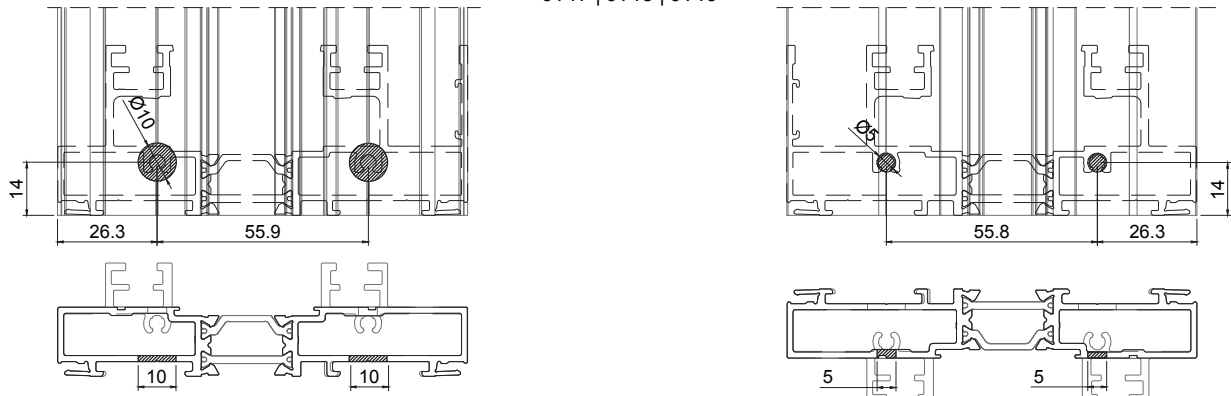

JT27 | JT28 | JT29

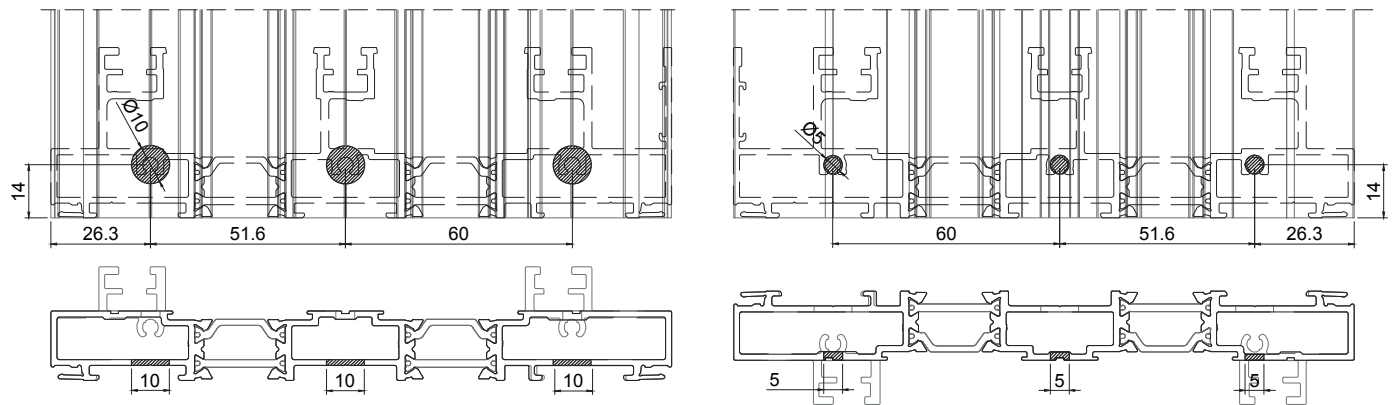

JT37 | JT38 | JT39 | JT43

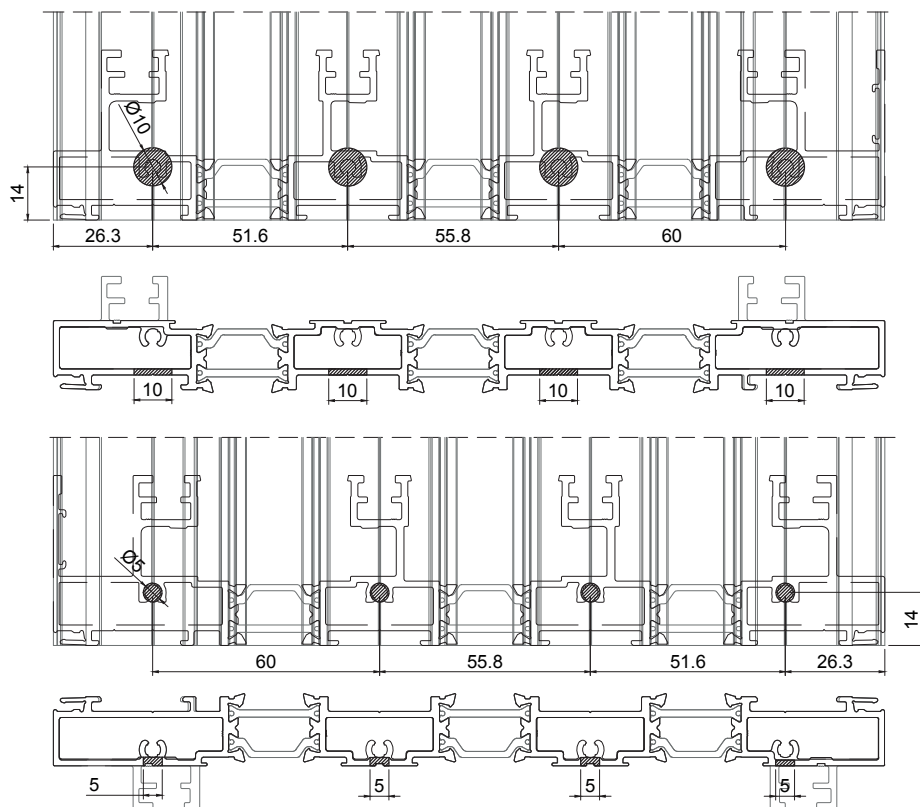

**MAQUINAÇÃO DOS PERFIS ARO FIXO PARA APLICAÇÃO COM SOLEIRA 30MM (CORTE 90°)**

FIXED FRAME PROFILES MACHINING FOR APPLICATION WITH 30MM SILL PROFILE (90° CUT)

USINAGE DES PROFILÉS DORMANT POUR APPLICATION DE SEUIL 30MM (COUPE 90°)

**2 - Maquinação dos perfis ombreira.**

Jamb profiles machining.

Usinage des profilés jambage.

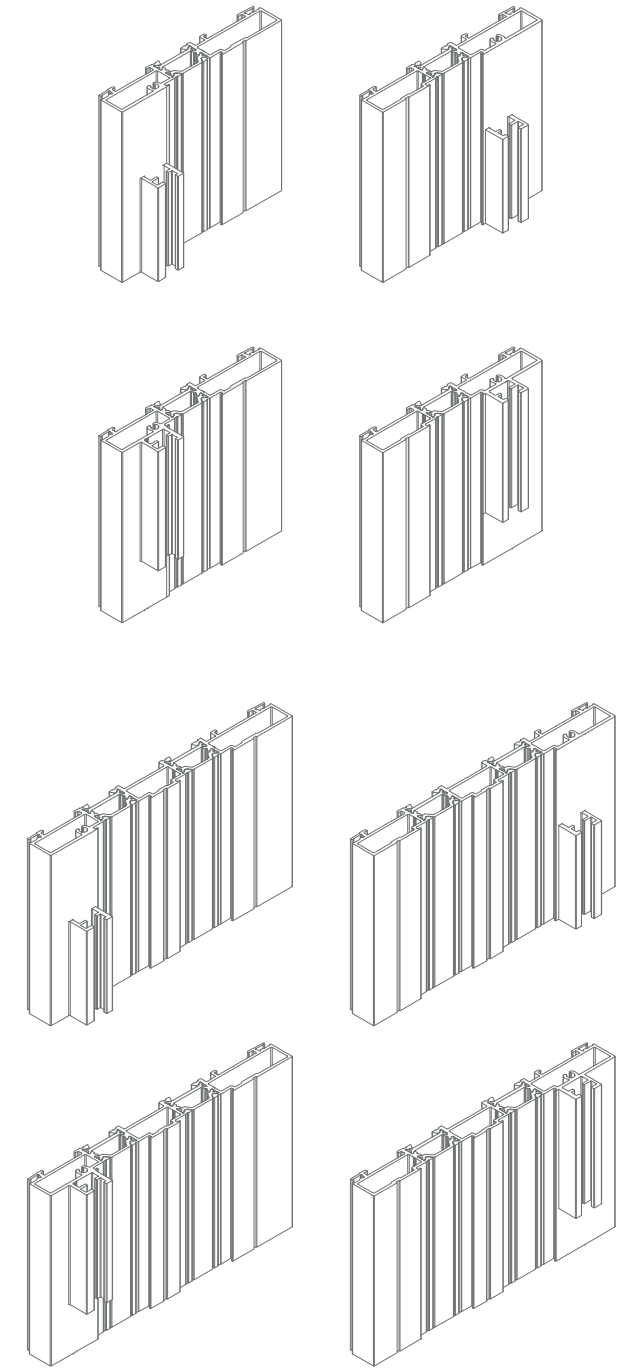
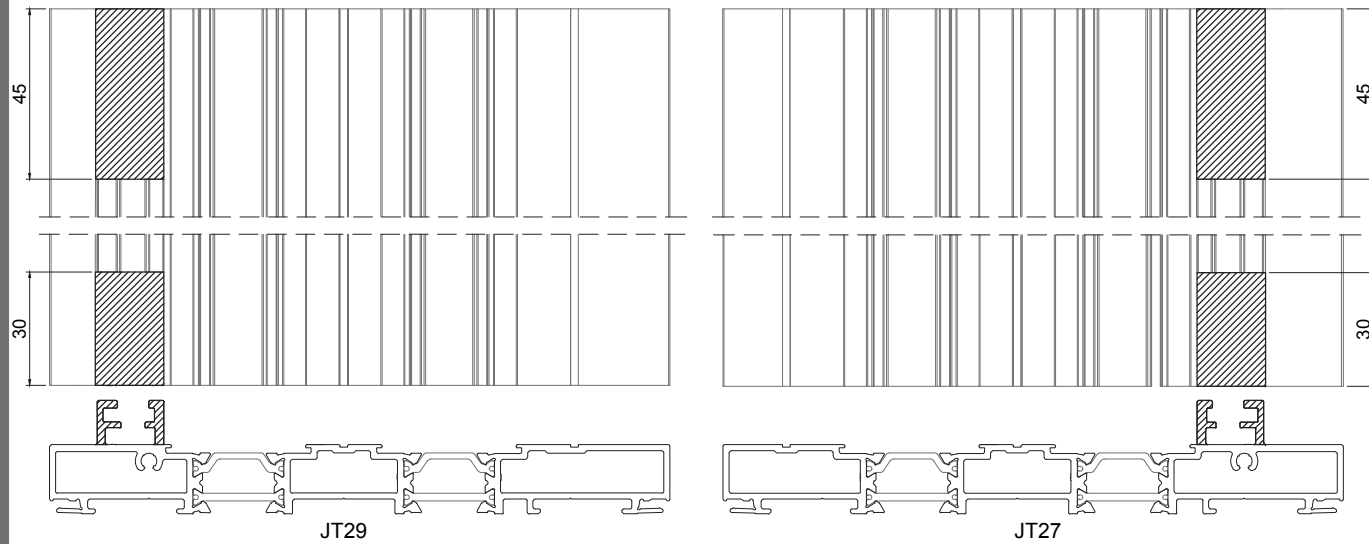
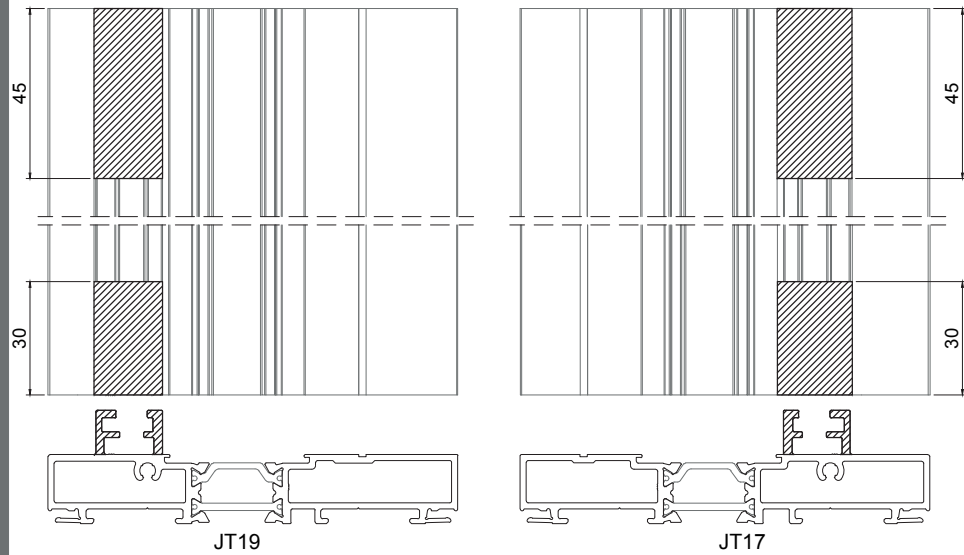

**MAQUINAÇÃO DOS PERFIS ARO FIXO PARA APLICAÇÃO COM SOLEIRA 30MM (CORTE 90°)**

FIXED FRAME PROFILES MACHINING FOR APPLICATION WITH 30MM SILL PROFILE (90° CUT)

USINAGE DES PROFILÉS DORMANT POUR APPLICATION DE SEUIL 30MM (COUPE 90°)

**2 - Maquinação dos perfis ombreira.**

Jamb profiles machining.

Usinage des profilés jambage.

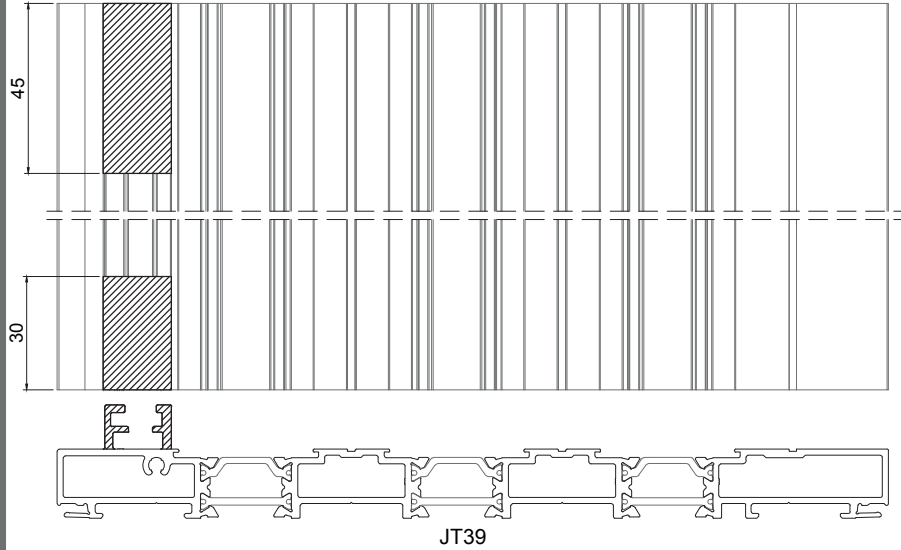

JT39

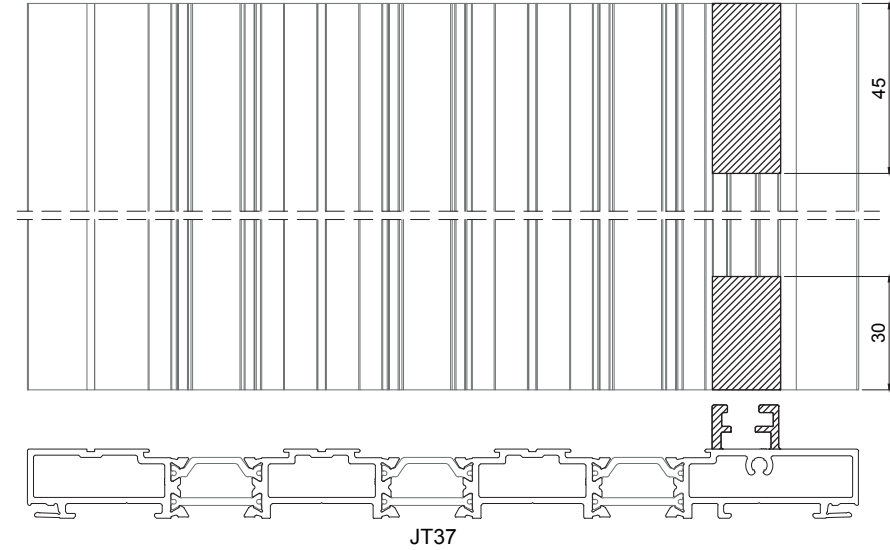
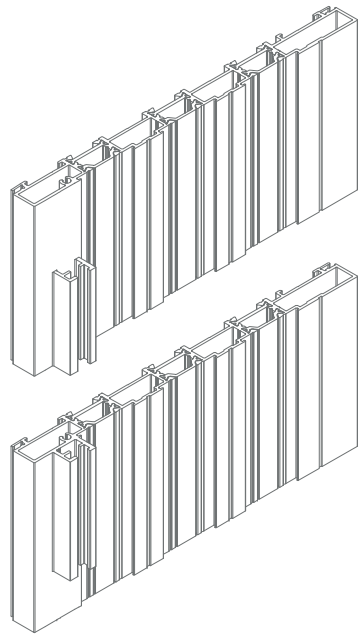

JT37

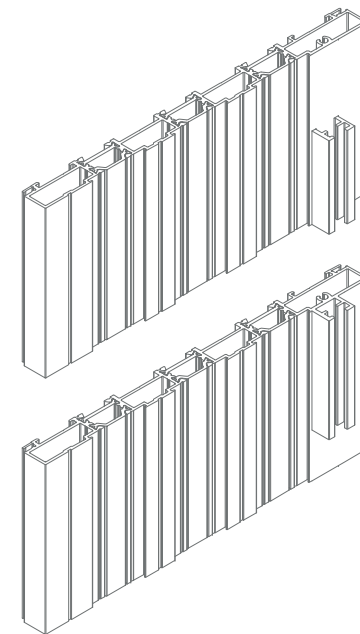

**MAQUINAÇÃO DOS PERFIS ARO FIXO PARA APLICAÇÃO COM SOLEIRA 30MM (CORTE 90°)**  
FIXED FRAME PROFILES MACHINING FOR APPLICATION WITH 30MM SILL PROFILE (90° CUT)  
USINAGE DES PROFILÉS DORMANT POUR APPLICATION DE SEUIL 30MM (COUPE 90°)

**3 - Furação dos perfis guias laterais JT78 and JT79.**

JT78 and JT79 lateral guides profiles drilling.

Perçage des profilés de guidage pour jambage JT78 et JT79.

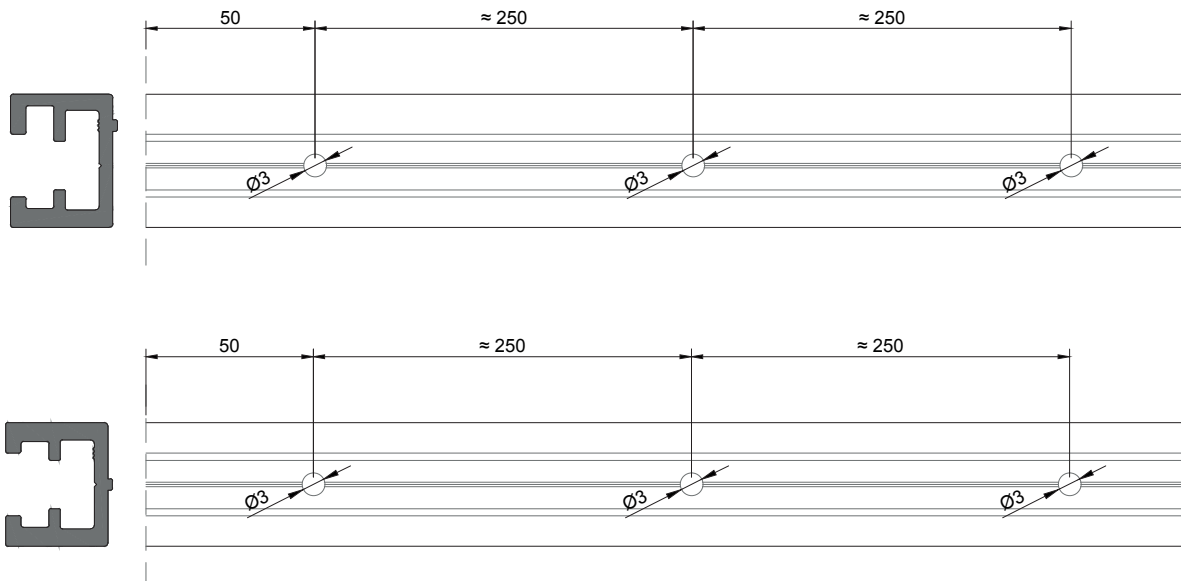

**4 - Maquinação do perfil pingadeira JT82.**

JT82 drip profile machining.

Usinage du profilé larmier JT82.

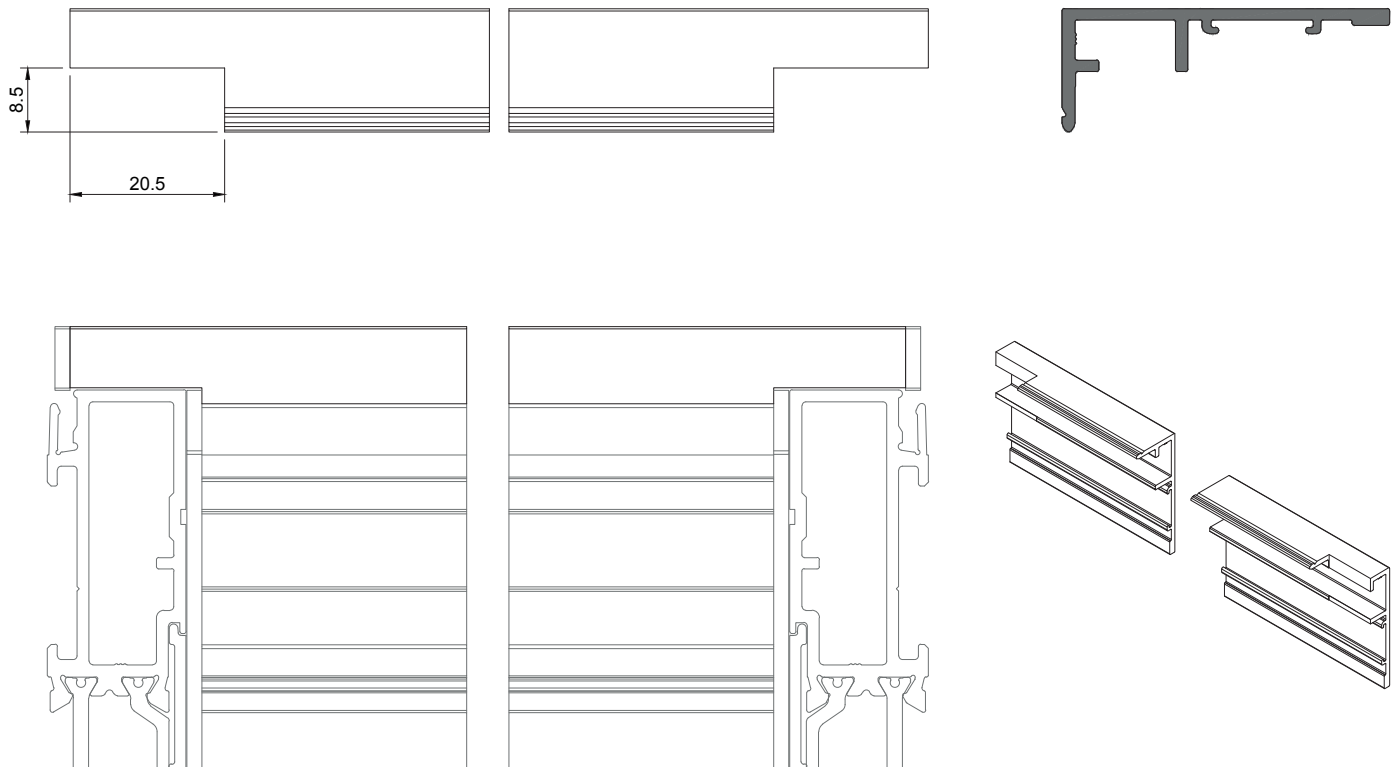

**MAQUINAÇÃO DOS PERFIS ARO FIXO PT (CORTE 45°) PARA APLICAÇÃO COM SOLEIRA 30MM (CORTE 90°)**  
**PT FIXED FRAME PROFILES MACHINING (45° CUT) FOR APPLICATION WITH 30MM SILL PROFILE (90° CUT)**  
**USINAGE DES PROFILÉS DORMANT PT (COUPE 45°) POUR APPLICATION DE SEUIL 30MM (COUPE 90°)**

**1 - Maquinação dos perfis de ombreira.**

Jamb profiles machining.

Usinage des profilés de jambage.

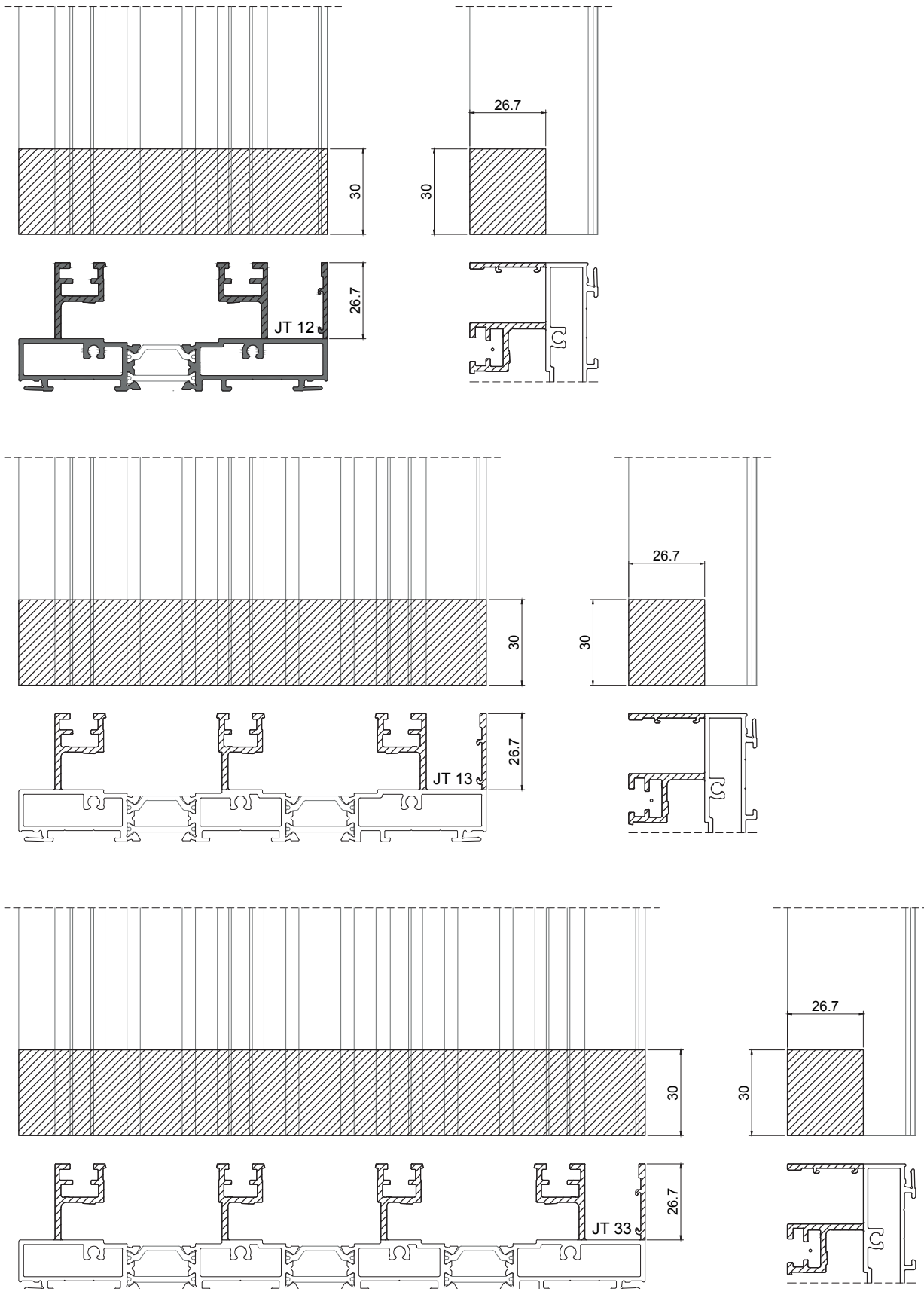

**MAQUINAÇÃO DOS PERFIS ARO FIXO PT (CORTE 45°) PARA APLICAÇÃO COM SOLEIRA 30MM (CORTE 90°)**  
**PT FIXED FRAME PROFILES MACHINING (45° CUT) FOR APPLICATION WITH 30MM SILL PROFILE (90° CUT)**  
**USINAGE DES PROFILÉS DORMANT PT (COUPE 45°) POUR APPLICATION DE SEUIL 30MM (COUPE 90°)**

**2 - Furação dos perfis de ombreira.**

Jamb profiles drilling.

Perçage des profilés de jambage.

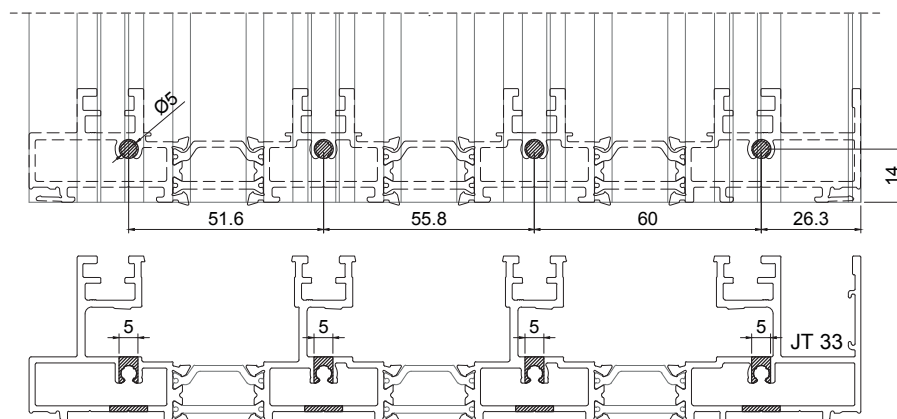
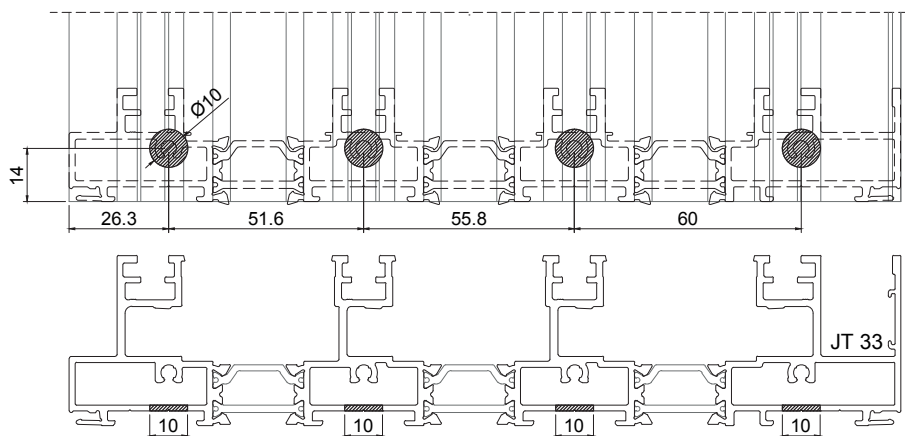
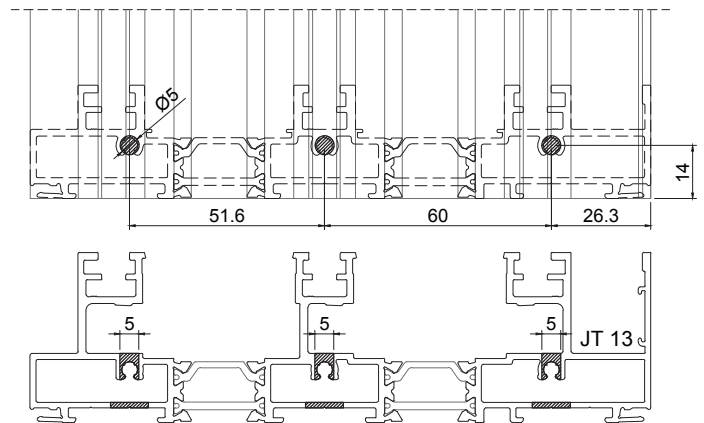
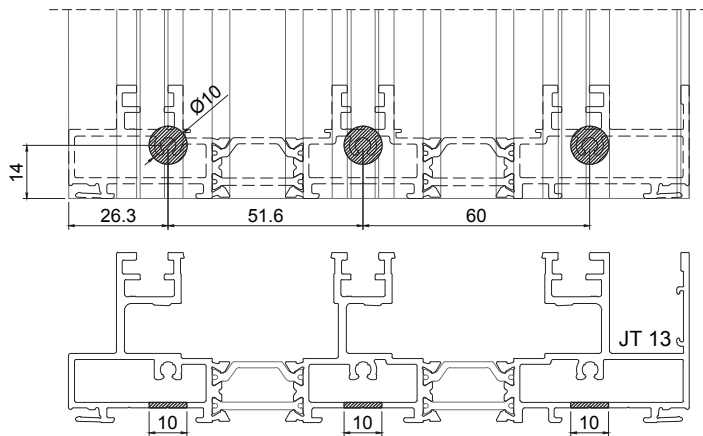
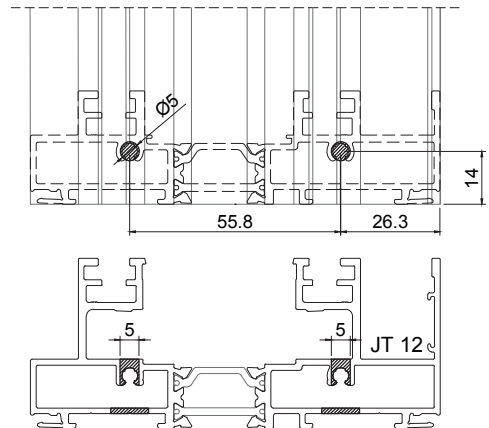
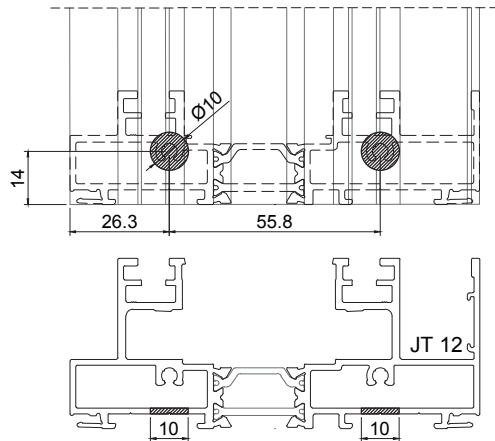



**MAQUINAÇÕES DE PERFIS DE CAPA**  
COVER PROFILES MACHINING  
USINAGE DES PROFILÉS DE CAPOT

1- Corte, entalhes e aplicação das capas JT85, JT86 e JT88.  
Cutting, milling and applying the JT85, JT86 and JT88 cover profiles.  
Découpe, fraisage et application des capots JT85, JT86 et JT88.

1.1 - Medidas de corte. A medida de corte dos perfis de capa varia consoante a aplicação ou não do perfil PVC T:  
Cutting measures. Cover profiles cutting measure varies depending on the application or not of the T PVC profile:  
Mesures de coupe. La mesure de la coupe du profilés de capot varie selon que le profil PVC T est appliqué ou non:

Situação Situation   Situation	Medidas de Corte Cutting measures   Mesures de coupe		Esquema de aplicação Application scheme   Schéma d'application
	Aros   Frames   Cadre <b>FR</b>	Aros   Frames   Cadre <b>PT</b>	
Perfis PVC T aplicados: cima <b>e</b> baixo T PVC profiles applied: top <b>and</b> bottom Profilés en PVC T appliqués: haut <b>et</b> bas	H - 72	H - 65	
Perfis PVC T aplicados: cima <b>ou</b> baixo T PVC profiles applied: top <b>or</b> bottom Profilés en PVC T appliqués: haut <b>ou</b> bas	H - 58	H - 51	
Caixilho sem aplicação de perfis PVC T Frame without T PVC profiles applied Cadre sans application de profilés PVC T	H - 45	H - 38	

1.2 - Maquinação dos perfis.  
Profiles machining.  
Usinage des profilés.

1.2.1- Quando aplicados na vertical, os perfis necessitam de maquinações conforme esquemas abaixo, em ambas as extremidades.  
When applied vertically, the profiles require machining according to the diagrams below, at both ends.  
Lorsqu'ils sont appliqués verticalement, les profilés nécessitent un usinage selon les schémas ci-dessous, aux deux extrémités.

Aros | Frames | Cadre **FR**

Aros | Frames | Cadre **PT**

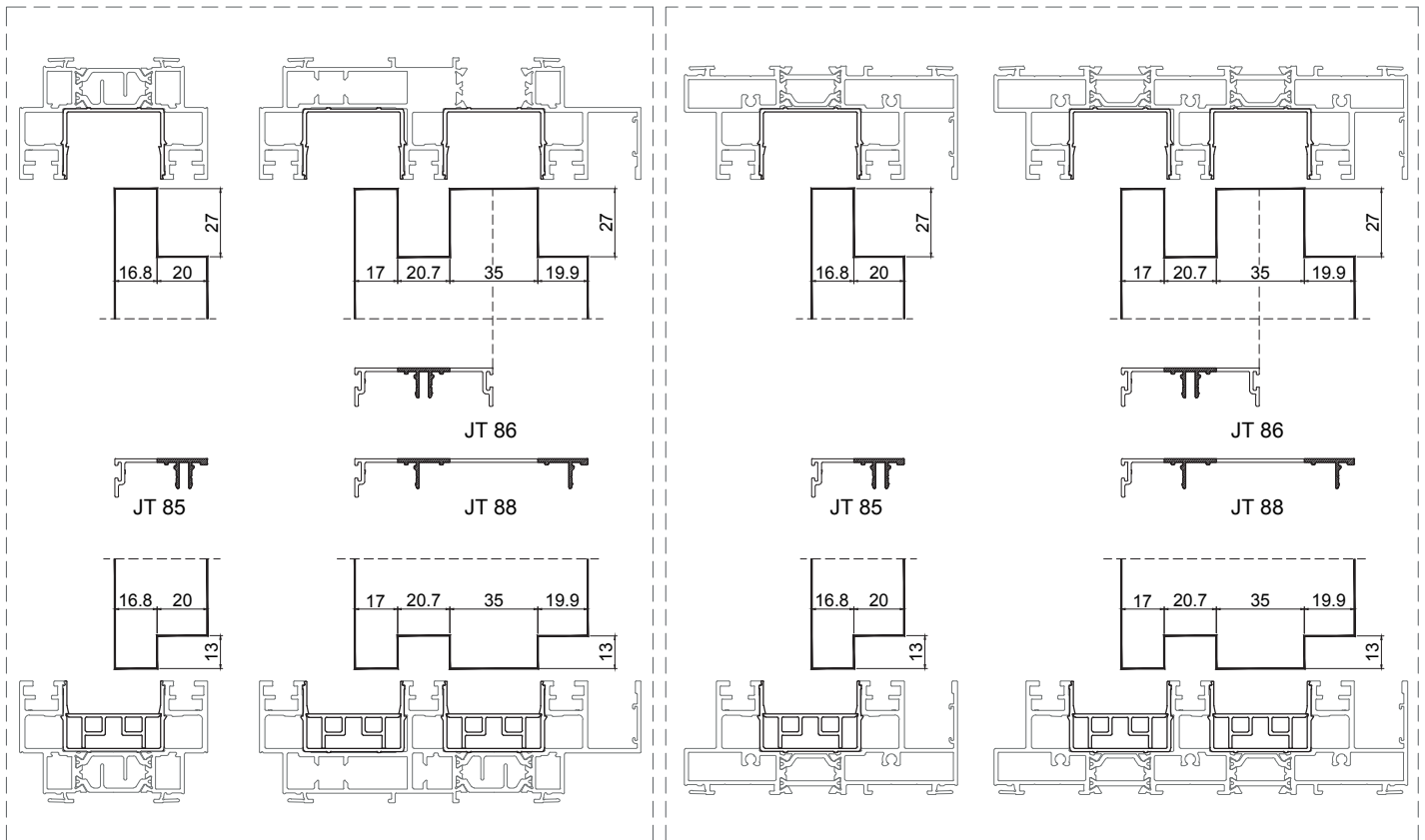

1.2.2 - Quando aplicados na horizontal, o corte destes perfis deverá ser reto e sem maquinações.  
When applied horizontally, the cut of these profiles should be straight and without machining.  
Lorsqu'ils sont appliqués horizontalement, la coupe de ces profilés doit être rectiligne et sans usinage.

**MAQUINAÇÕES DE PERFIS DE CAPA**

**COVER PROFILES MACHINING**

**USINAGE DES PROFILÉS DE CAPOT**

**2 - Corte, entalhes e aplicação das capas JT90, JT91 e JT92.**

Cutting, milling and applying the JT90, JT91 and JT92 cover profiles.

Découpe, fraisage et application des capots JT90, JT91 et JT92.

**2.1 - Medidas de corte. A medida de corte dos perfis de capa varia consoante a aplicação ou não do perfil PVC T:**

Cutting measures. Cover profiles cutting measure varies depending on the application or not of the T PVC profile:

Mesures de coupe. La mesure de la coupe du profilés de capot varie selon que le profil PVC T est appliqué ou non:

Situação Situation   Situation	Medidas de Corte Cutting measures   Mesures de coupe			Esquema de aplicação Application scheme   Schéma d'application
	Aros   Frames   Cadre <b>PT</b>			
	JT 90	JT 91	JT 92	
Perfis PVC T aplicados: cima e baixo T PVC profiles applied: top and bottom Profilés en PVC T appliqués: haut et bas	H - 37	H - 65	H - 37	
Perfis PVC T aplicados: cima ou baixo T PVC profiles applied: top or bottom Profilés en PVC T appliqués: haut ou bas		H - 51		
Caixilho sem aplicação de perfis PVC T Frame without T PVC profiles applied Cadre sans application de profilés PVC T		H - 37		

**2.2 - Maquinação dos perfis.**

Profiles machining.

Usinage des profilés.

**2.2.1- Quando aplicados na vertical, os perfis necessitam de maquinações conforme esquemas abaixo, em ambas as extremidades.**

When applied vertically, the profiles require machining according to the diagrams below, at both ends.

Lorsqu'ils sont appliqués verticalement, les profilés nécessitent un usinage selon les schémas ci-dessous, aux deux extrémités.

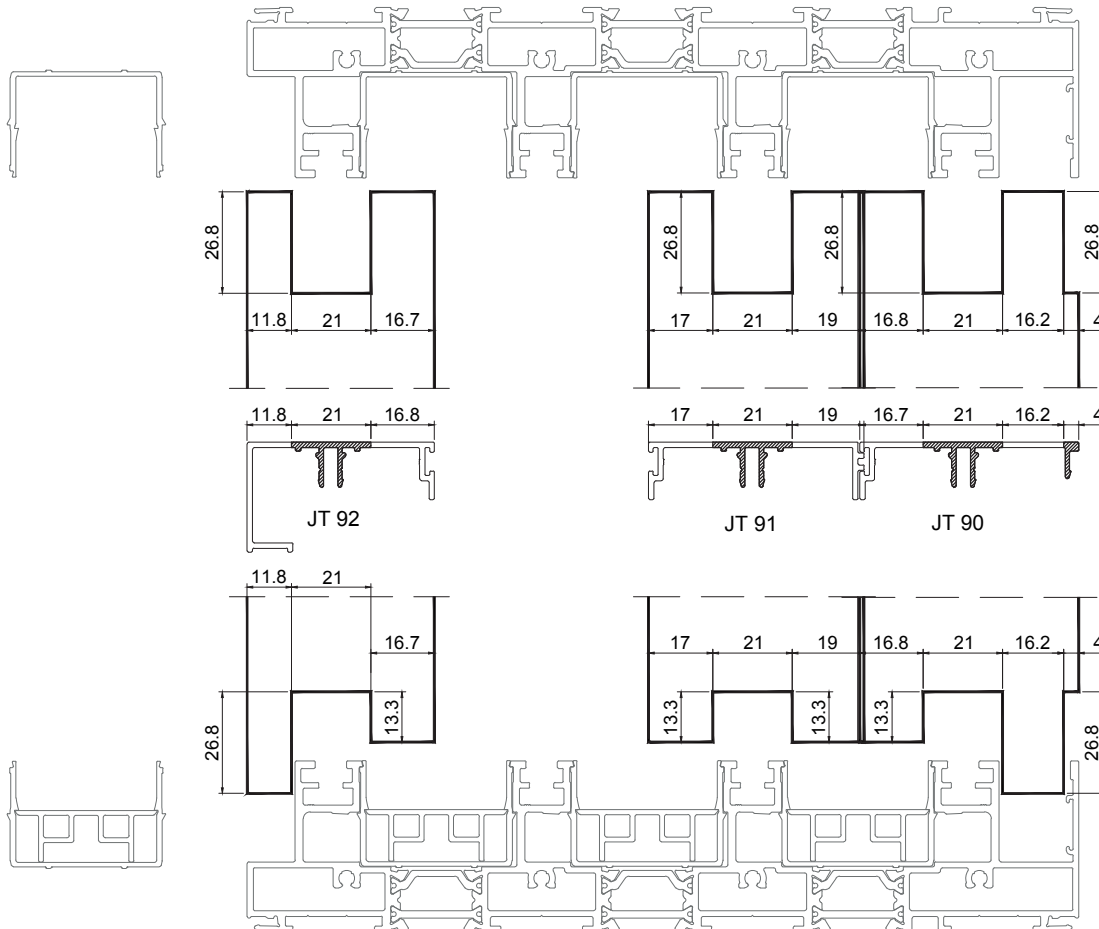

**2.2.2 - Quando aplicados na horizontal, o corte destes perfis deverá ser reto e sem maquinações.**

When applied horizontally, the cut of these profiles should be straight and without machining.

Lorsqu'ils sont appliqués horizontalement, la coupe de ces profilés doit être rectiligne et sans usinage.

**MAQUINAÇÕES DE PERFIS DE CAPA**

**COVER PROFILES MACHINING**

**USINAGE DES PROFILÉS DE CAPOT**

**3 - Corte, entalhes e aplicação das capas JT89 e JT 91 (tipologias fixas).**

Cutting, milling and applying the JT89 and JT91 cover profiles (fixed typologies).  
Découpe, fraisage et application des capots JT89 et JT91 (typologies fixes).

**3.1 - Medidas de corte.**

Cutting measures.  
Mesures de coupe.

Situação Situation   Situation	Medidas de Corte Cutting measures   Mesures de coupe
Corte horizontal Horizontal cut Coupe horizontal	Conforme tipologia According to typology Selon le typologie
Corte vertical Vertical cut Coupe vertical	H - 62

**3.2 - Maquinação dos perfis.**

Profiles machining.  
Usinage des profilés.

**3.2.1- Quando aplicados na vertical, os perfis necessitam de maquinações conforme esquemas abaixo, em ambas as extremidades.**

When applied vertically, the profiles require machining according to the diagrams below, at both ends.

Lorsqu'ils sont appliqués verticalement, les profilés nécessitent un usinage selon les schémas ci-dessous, aux deux extrémités.

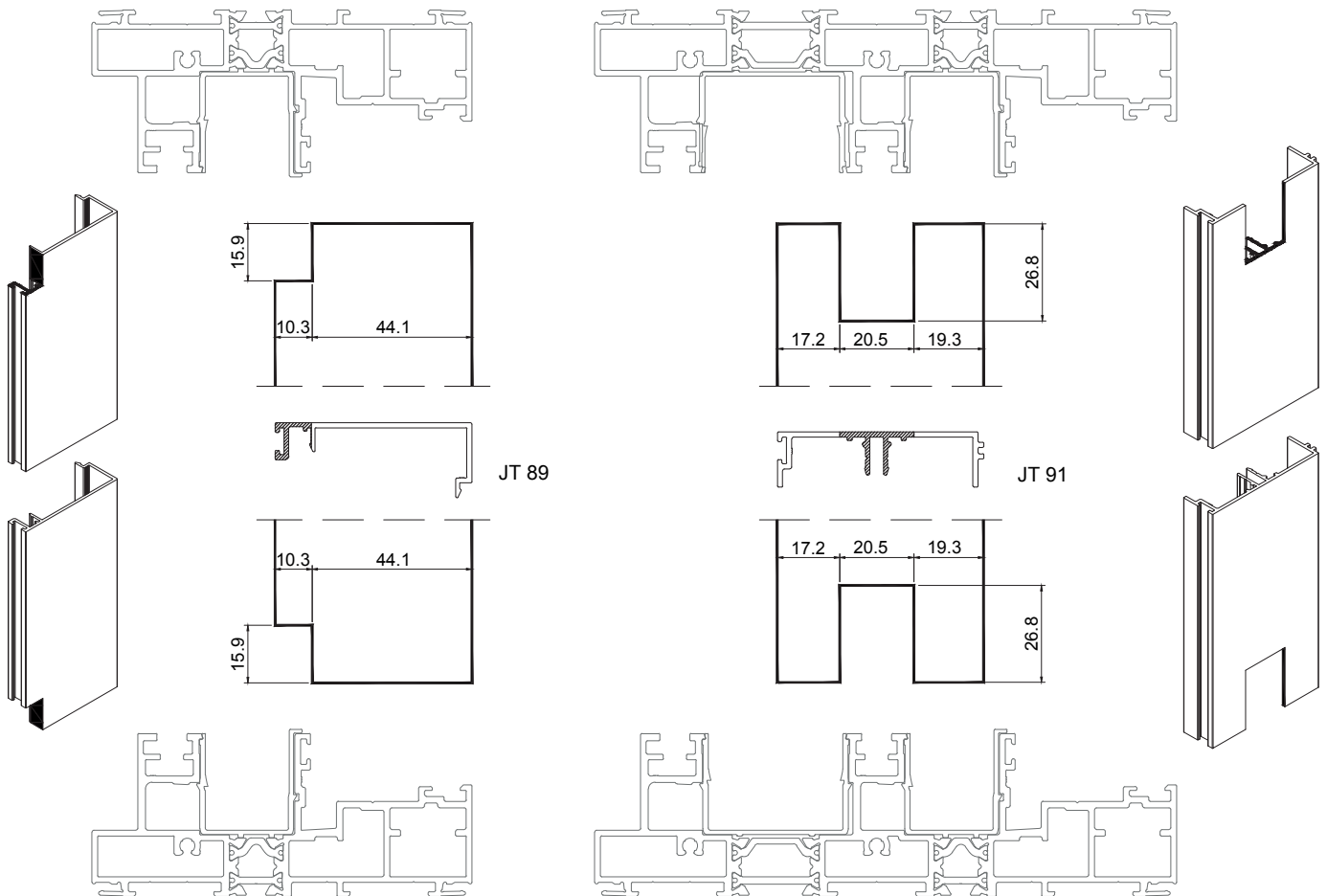

**3.2.2 - Quando aplicados na horizontal, o corte destes perfis deverá ser reto e sem maquinações.**

When applied horizontally, the cut of these profiles should be straight and without machining.

Lorsqu'ils sont appliqués horizontalement, la coupe de ces profilés doit être rectiligne et sans usinage.

MAQUINAÇÕES DE PERFIS MONTANTES  
 MULLION PROFILES MACHINING  
 USINAGE DES PROFILÉS MENEAX

1 - Medidas de corte dos Perfis montantes e das Juntas Centrais.  
 Mullion profiles and Central Joints cutting measures.  
 Mesures de coupe des Profilés meneaux et des Joint Centraux.

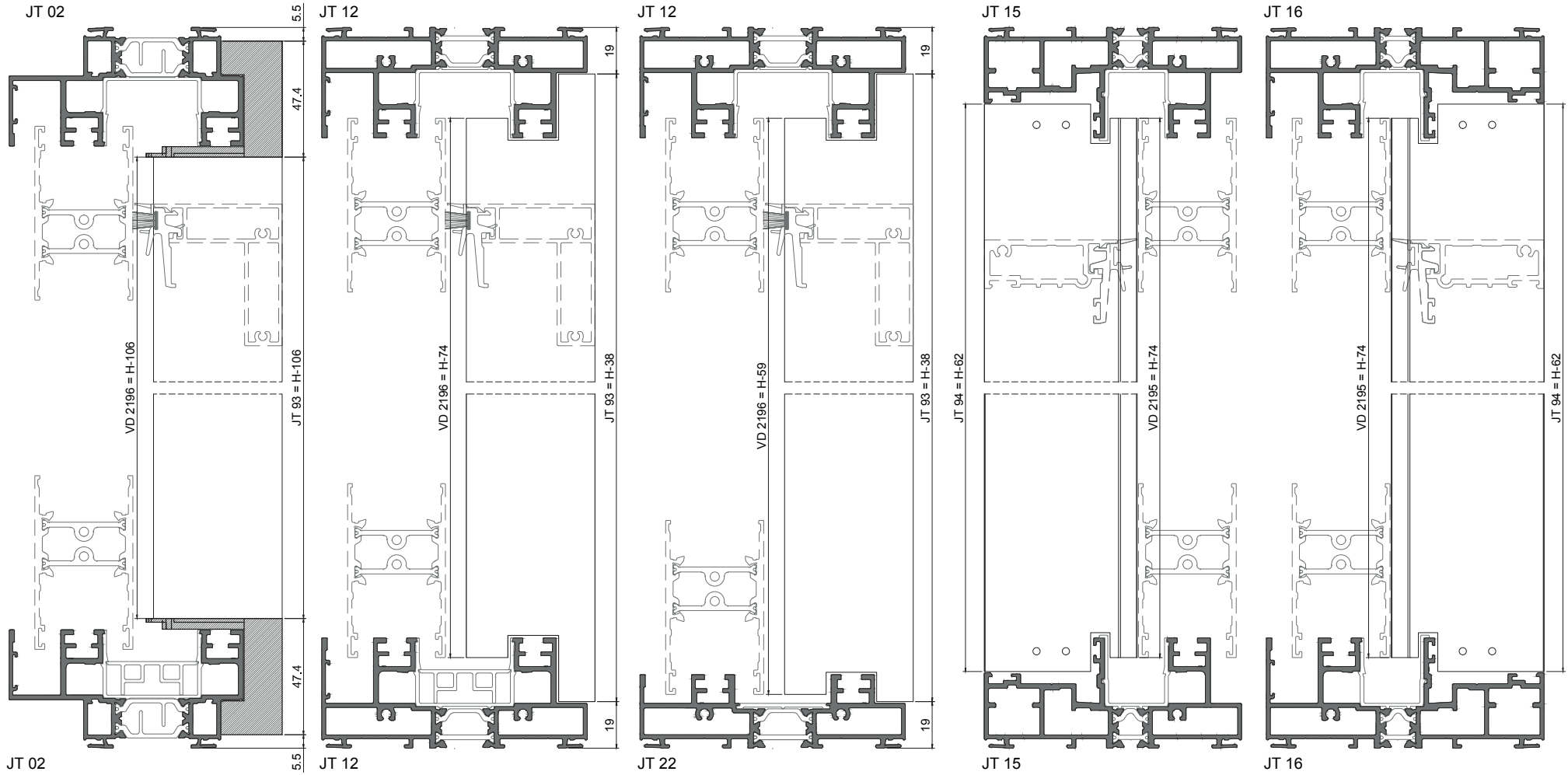

# MAQUINAÇÕES DE PERFIS MONTANTES

MULLION PROFILES MACHINING

USINAGE DES PROFILÉS MENEUX

## 2 - Maquinação dos perfis montantes.

Mullion profiles milling.

Fraisage des profilés meneaux.

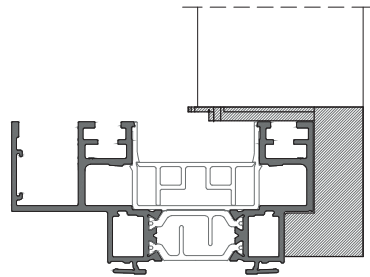

JT 02

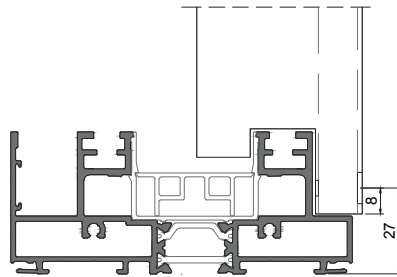

JT 12

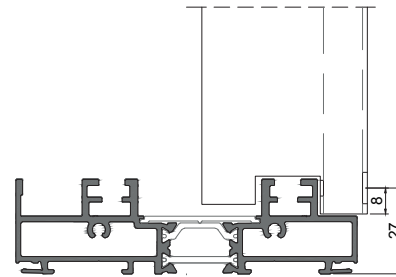

JT 22

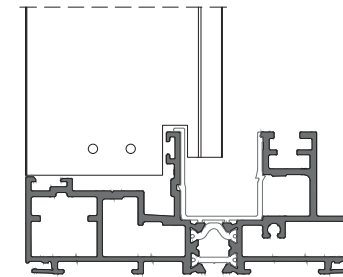

JT 15

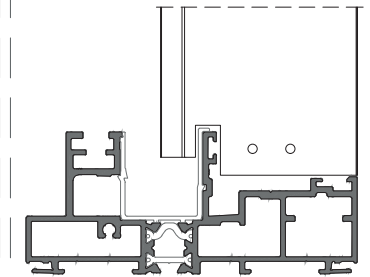

JT 16

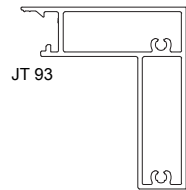

JT 93

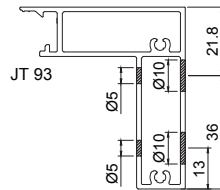

JT 93

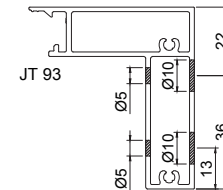

JT 93

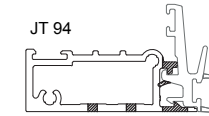

JT 94

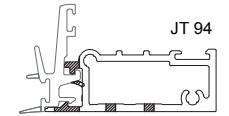

JT 94

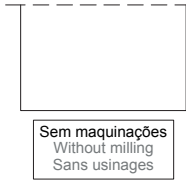

Sem maquinações  
Without milling  
Sans usinages

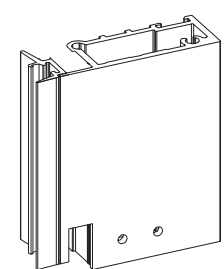
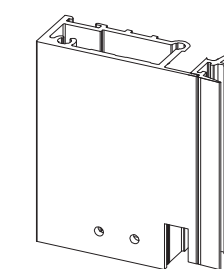
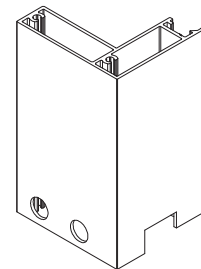
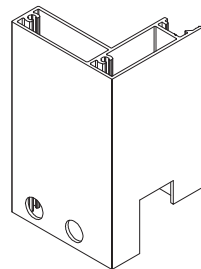
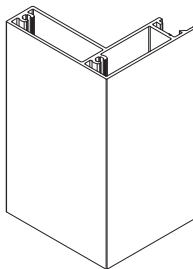
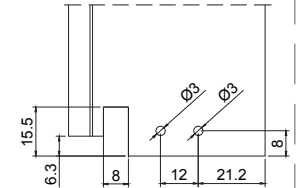
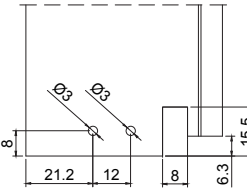
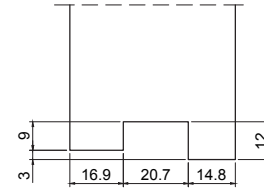
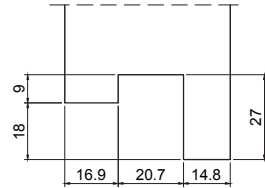

**Nota | Note | Remarque:**  
Esta operação deverá ser feita com os 2 perfis juntos.  
This operation must be done with the 2 profiles together.  
Cette opération doit se faire avec les 2 profilés ensemble.

**Nota | Note | Remarque:**  
Esta operação deverá ser feita com os 2 perfis juntos.  
This operation must be done with the 2 profiles together.  
Cette opération doit se faire avec les 2 profilés ensemble.

**MAQUINAÇÃO DOS PERFIS GUIA E VEDANTE TAPA CANAL 2116**  
GUIDE PROFILE AND 2116 CHANNEL COVER JOINT MACHINING  
USINAGE DU PROFILÉ GUIDE ET DE LA JOINT DE COUVERTURE DU CHANNEL 2116

1 - Perfil guia JT 87.  
JT 87 Guide profile.  
Profilé guide JT 87.

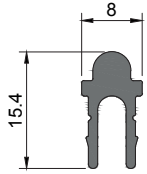

**JT 87**  
Guia  
Guide | Guide

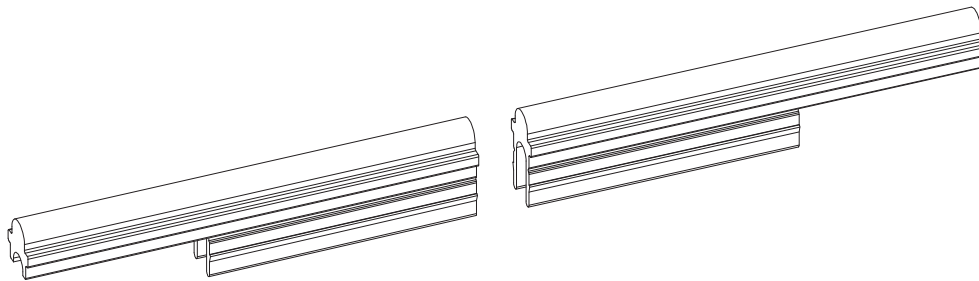
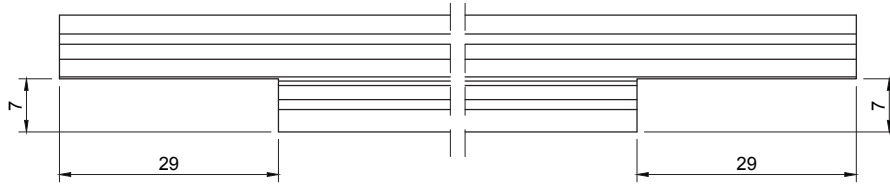
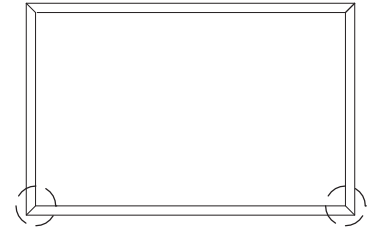

2 - Junta tapa canal 2116.  
2116 Channel cover joint.  
Joint de couverture du channel 2116.

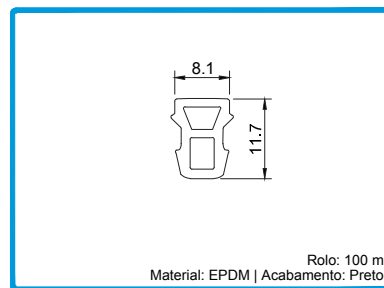

208348 JUNTA TAPA CANAL 2116 JT

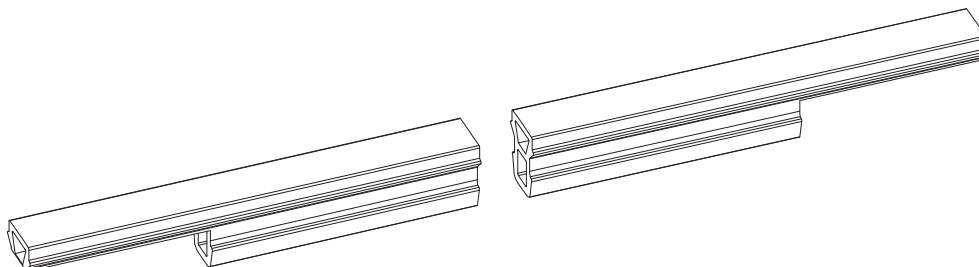
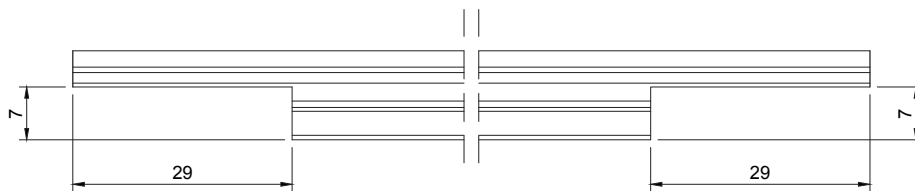
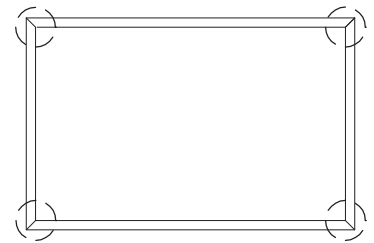



**DRENAGENS POR TIPOLOGIA**  
**DRAINAGE BY FRAME TYPOLOGY**  
**DRAINAGE PAR TYPOLOGIE**

1 - Pormenores de drenagem para os perfis de aro fixo **FR 2rail** e perfis de PVC, para tipologias de 2 folhas. **Seguir este procedimento em todos os perfis aro fixo FR 2rail.**  
 Drainage details of fixed 2rail **FR** frame profiles and PVC profiles, for 2 sashes typologies. **Follow this procedure in all 2rail FR fixed frame profiles.**  
 Détails de drainage pour profilés dormant **FR 2rail** et profilés PVC, pour les typologies à 2 vantaux. **Suivre cette procédure sur tous les profilés dormant FR 2rail.**

- R1:** Rasgo | Hole | Rainure 6x30mm
- R2:** Rasgo | Hole | Rainure 6x35mm
- R3:** Rasgo | Hole | Rainure 5x20mm
- R4:** Rasgo | Hole | Rainure 6x35mm
- R5:** Rasgo | Hole | Rainure 6x35mm

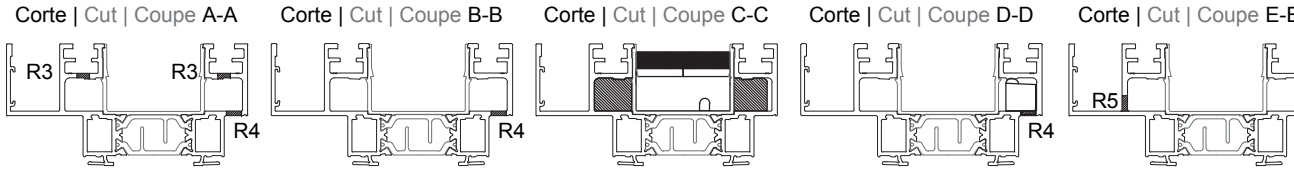
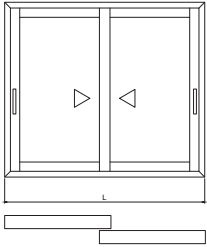

Corte | Cut | Coupe A-A  
 Corte | Cut | Coupe B-B  
 Corte | Cut | Coupe D-D  
 Corte | Cut | Coupe E-E

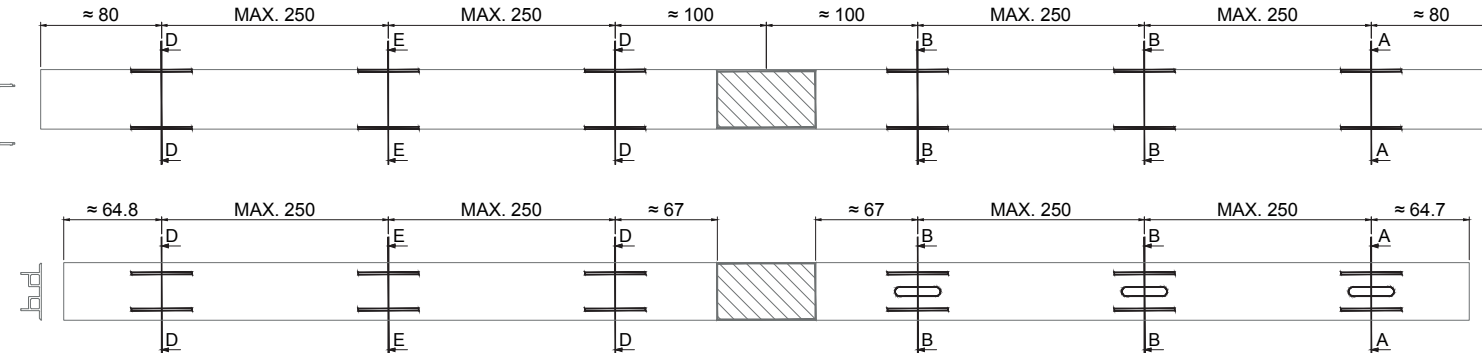
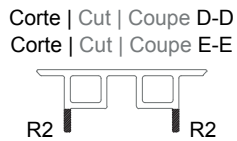
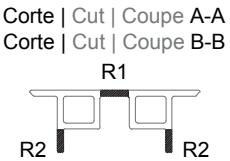
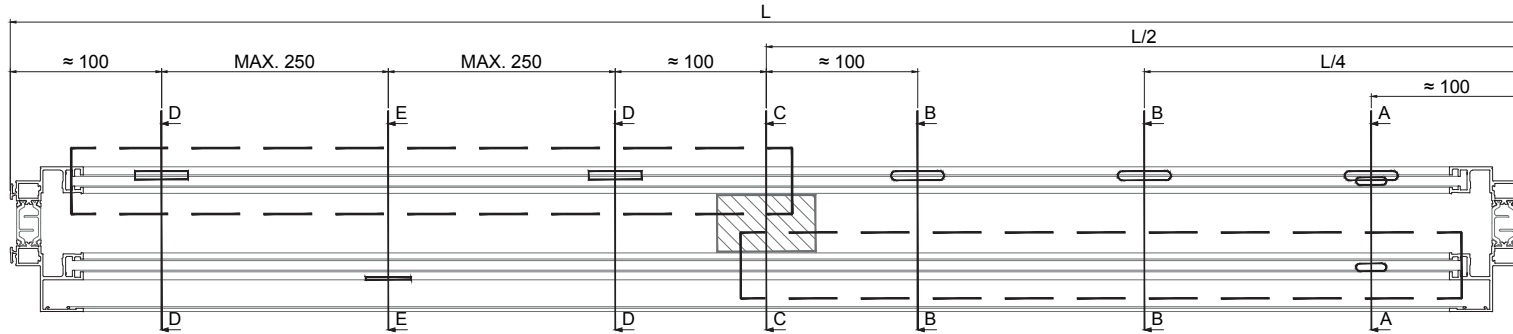

Para drenagem alternativa inferior, consultar o Departamento Técnico.  
 For alternative bottom drainage, consult the Technical Department.  
 Pour un drainage alternatif inférieur, consulter le Département Technique.

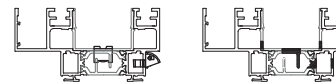

**DRENAGENS POR TIPOLOGIA**  
**DRAINAGE BY FRAME TYPOLOGY**  
**DRAINAGE PAR TYPOLOGIE**

2 - Pormenores de drenagem para os perfis de aro fixo **FR 2rail** e perfis de PVC, para tipologias de 3 folhas. **Seguir este procedimento em todos os perfis aro fixo FR 2rail.**  
 Drainage details of fixed 3rail **FR** frame profiles and PVC profiles, for 3 sashes typologies. **Follow this procedure in all 2rail FR fixed frame profiles.**  
 Détails de drainage pour profilés dormant **FR 2rail** et profilés PVC, pour les typologies à 3 vantaux. **Suivre cette procédure sur tous les profilés dormant FR 2rail.**

- R1:** Rasgo | Hole | Rainure 6x30mm
- R2:** Rasgo | Hole | Rainure 6x35mm
- R3:** Rasgo | Hole | Rainure 5x20mm
- R4:** Rasgo | Hole | Rainure 6x35mm
- R5:** Rasgo | Hole | Rainure 6x35mm

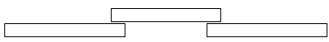
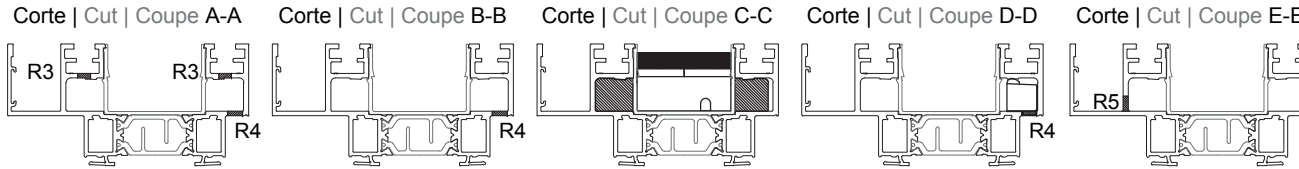
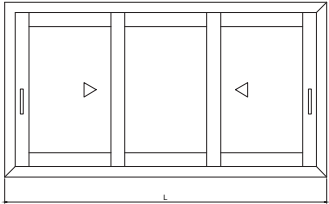

Corte | Cut | Coupe A-A  
 Corte | Cut | Coupe B-B  
 Corte | Cut | Coupe D-D  
 Corte | Cut | Coupe E-E

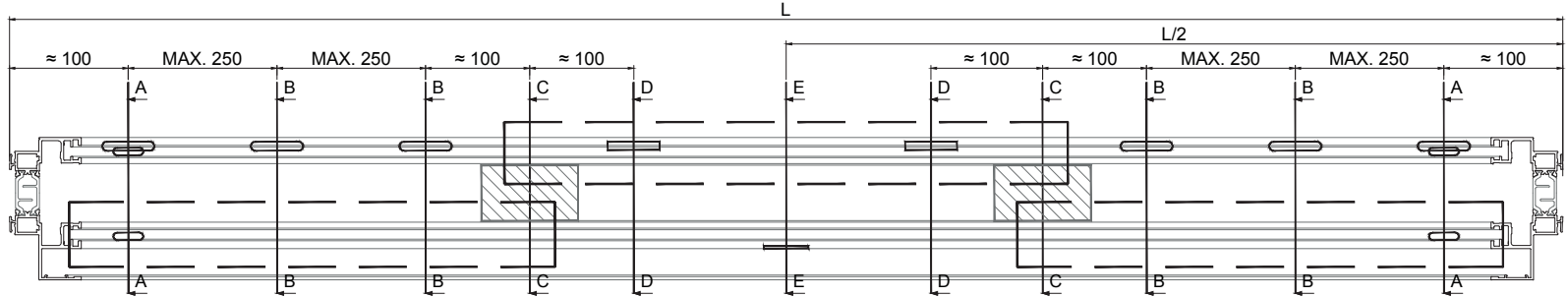

Corte | Cut | Coupe A-A  
 Corte | Cut | Coupe B-B

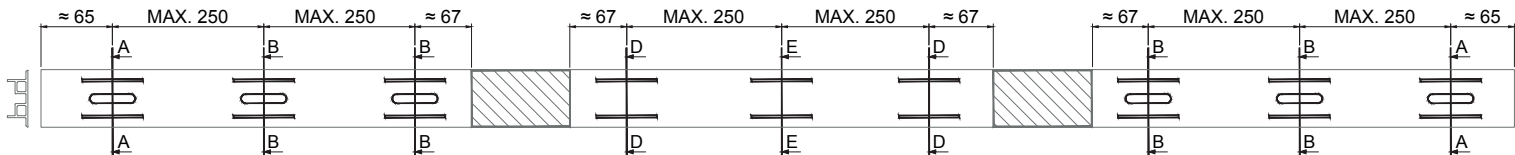
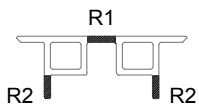

Corte | Cut | Coupe D-D  
 Corte | Cut | Coupe E-E

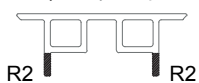

Para drenagem alternativa inferior, consultar o Departamento Técnico.  
 For alternative bottom drainage, consult the Technical Department.  
 Pour un drainage alternatif inférieur, consulter le Département Technique.

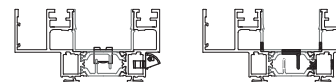

**DRENAGENS POR TIPOLOGIA**  
**DRAINAGE BY FRAME TYPOLOGY**  
**DRAINAGE PAR TYPOLOGIE**

**3 - Pormenores de drenagem para os perfis de aro fixo FR 2rail e perfis de PVC, para tipologias de 4 folhas. Seguir este procedimento em todos os perfis aro fixo FR 2rail.**  
 Drainage details of fixed 2rail FR frame profiles and PVC profiles, for 4 sashes typologies. Follow this procedure in all 2rail FR fixed frame profiles.  
 Détails de drainage pour profilés dormant FR 2rail et profilés PVC, pour les typologies à 4 vantaux. Suivre cette procédure sur tous les profilés dormant FR 2rail.

- R1:** Rasgo | Hole | Rainure 6x30mm
- R2:** Rasgo | Hole | Rainure 6x35mm
- R3:** Rasgo | Hole | Rainure 5x20mm
- R4:** Rasgo | Hole | Rainure 6x35mm
- R5:** Rasgo | Hole | Rainure 6x35mm

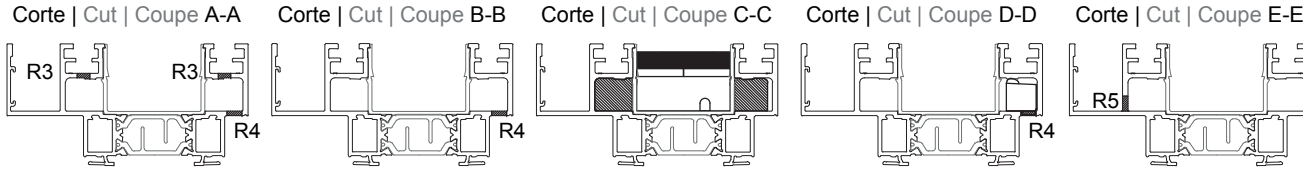
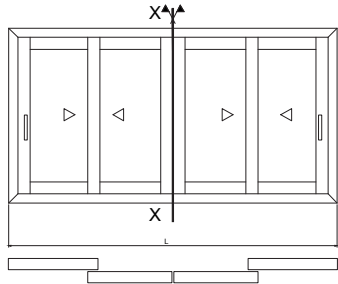

Corte | Cut | Coupe A-A  
 Corte | Cut | Coupe B-B  
 Corte | Cut | Coupe D-D  
 Corte | Cut | Coupe E-E

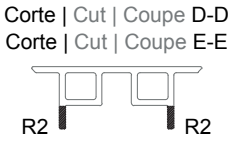
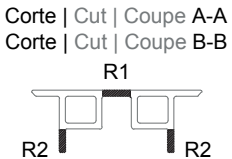
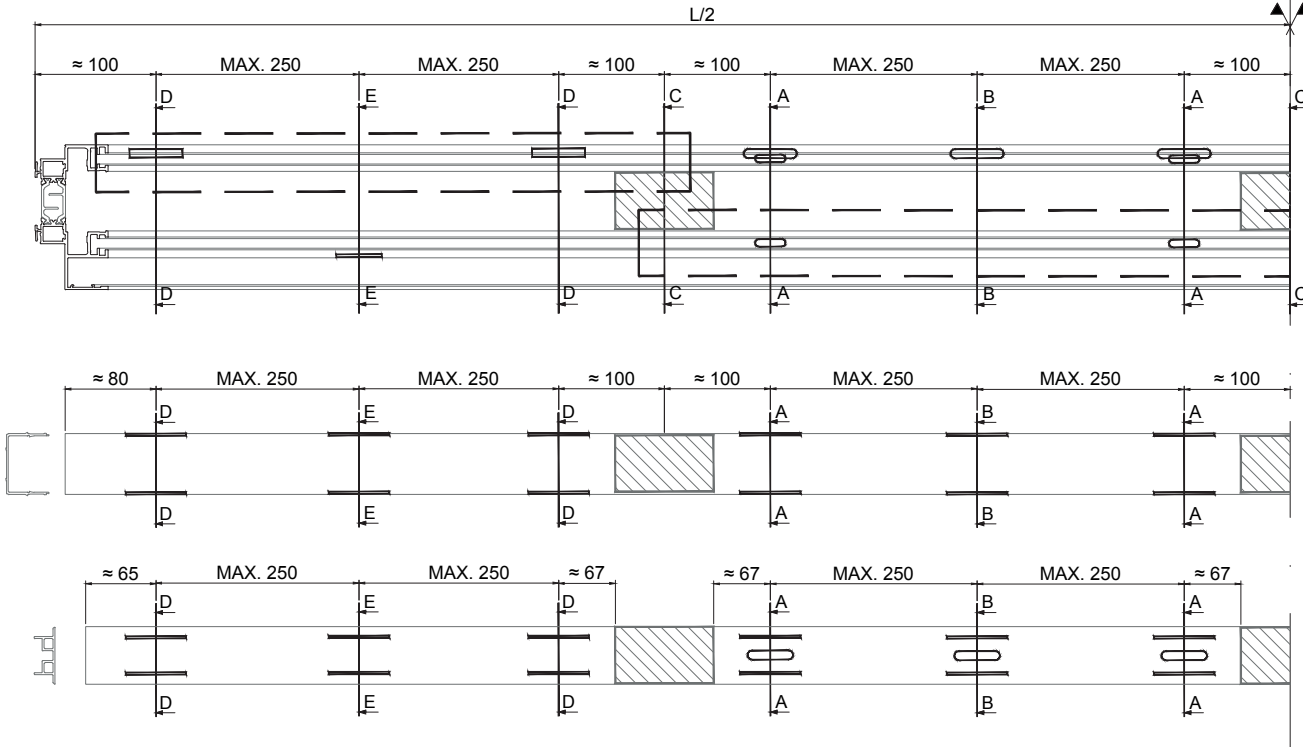

Para drenagem alternativa inferior, consultar o Departamento Técnico.  
 For alternative bottom drainage, consult the Technical Department.  
 Pour un drainage alternatif inférieur, consulter le Département Technique.

**DRENAGENS POR TIPOLOGIA**  
**DRAINAGE BY FRAME TYPOLOGY**  
**DRAINAGE PAR TYPOLOGIE**

**4 - Pormenores de drenagem para os perfis de aro fixo FR 3rail e perfis de PVC, para tipologias de 3 folhas.**  
 Drainage details of fixed 3rail FR frame profiles and PVC profiles, for 3 sashes typologies.  
 Détails de drainage pour profilés dormant FR 3rail et profilés PVC, pour les typologies à 3 vantaux.

- R1:** Rasgo | Hole | Rainure 6x30mm
- R2:** Rasgo | Hole | Rainure 6x35mm
- R3:** Rasgo | Hole | Rainure 5x20mm
- R4:** Rasgo | Hole | Rainure 6x35mm
- R5:** Rasgo | Hole | Rainure 6x35mm

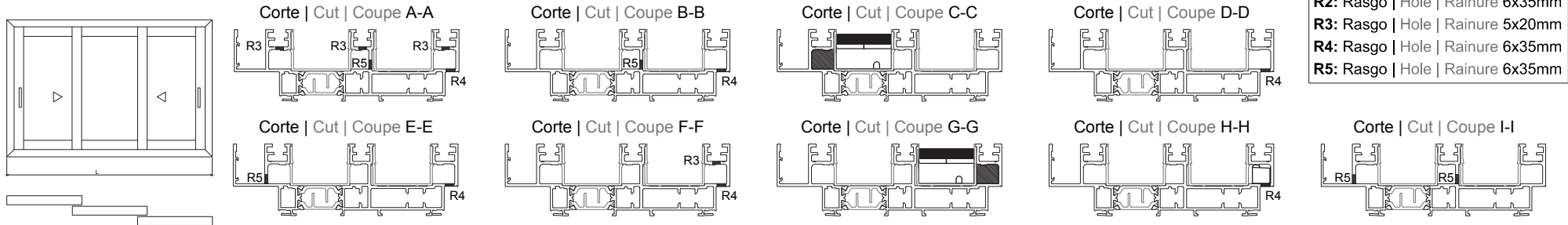

Cortes | Cuts | Coupes A-A | B-B  
 Cortes | Cuts | Coupes D-D | F-F  
 Cortes | Cuts | Coupes H-H | I-I



Cortes | Cuts | Coupes A-A | B-B  
 Cortes | Cuts | Coupes D-D | F-F

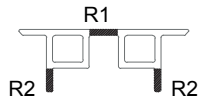

Cortes | Cuts | Coupes H-H | I-I

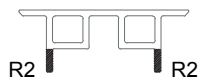

Para drenagem alternativa inferior, consultar o Departamento Técnico.  
 For alternative bottom drainage, consult the Technical Department.  
 Pour un drainage alternatif inférieur, consulter le Département Technique.

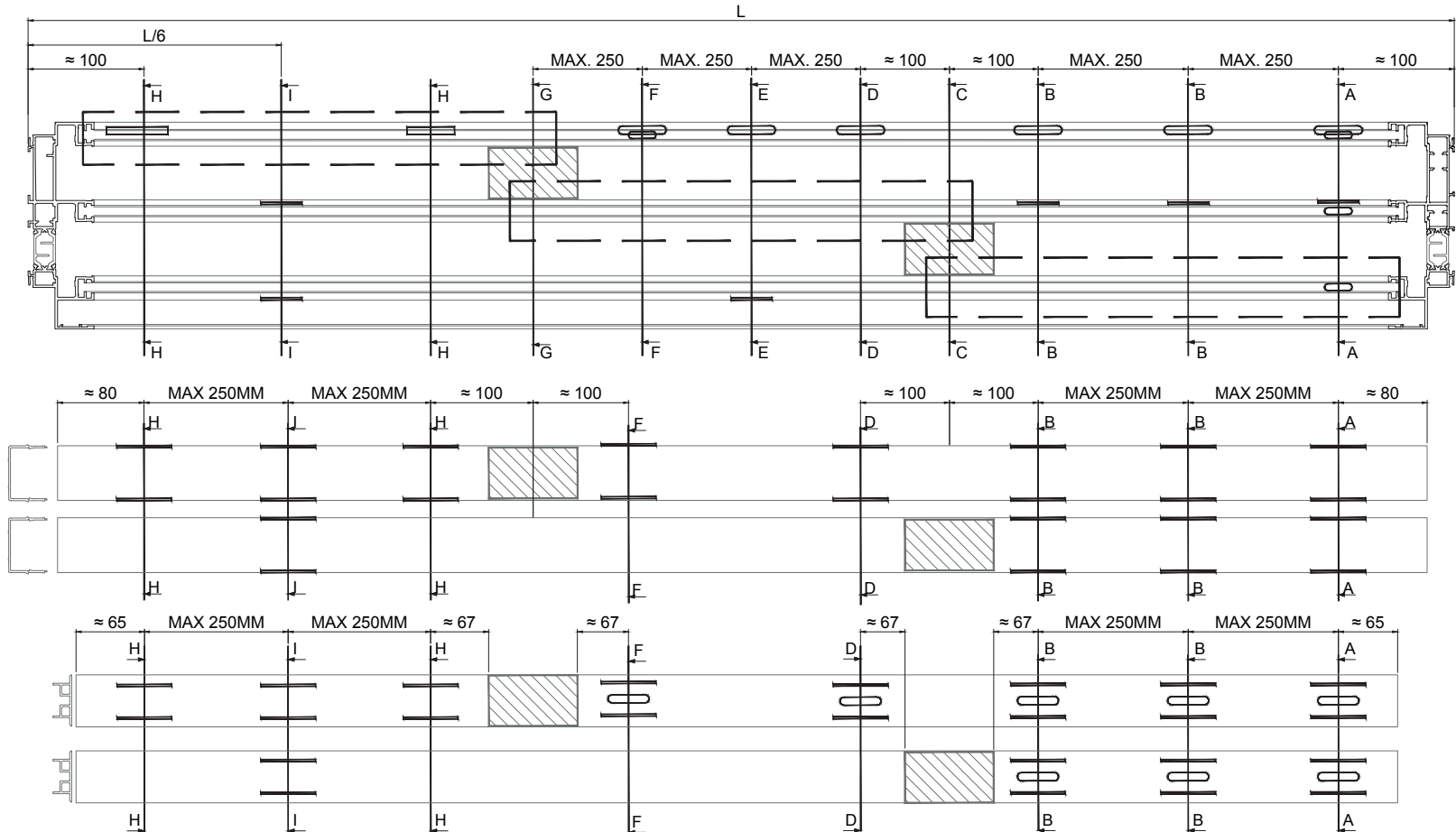
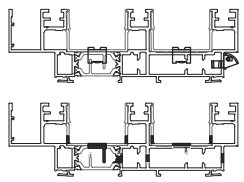

**DRENAGENS POR TIPOLOGIA**  
**DRAINAGE BY FRAME TYPOLOGY**  
**DRAINAGE PAR TYPOLOGIE**

5 - Pormenores de drenagem para os perfis de aro fixo **PT 2rail** e perfis de PVC, para tipologias de 2 folhas. **Seguir este procedimento em todos os perfis aro fixo PT 2rail.**  
 Drainage details of fixed 2rail **PT** frame profiles and PVC profiles, for 2 sashes typologies. **Follow this procedure in all 2rail PT fixed frame profiles.**  
 Détails de drainage pour profilés dormant **PT 2rail** et profilés PVC, pour les typologies à 2 vantaux. **Suivre cette procédure sur tous les profilés dormant PT 2rail.**

**R1:** Rasgo | Hole | Rainure 6x30mm  
**R2:** Rasgo | Hole | Rainure 5x30mm  
**R3:** Rasgo | Hole | Rainure 5x20mm  
**R5:** Rasgo | Hole | Rainure 5x30mm

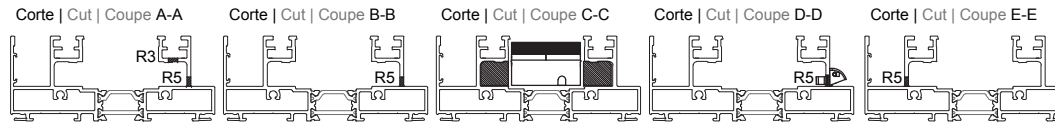
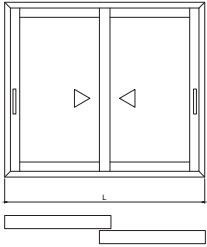

Corte | Cut | Coupe A-A  
 Corte | Cut | Coupe B-B  
 Corte | Cut | Coupe D-D  
 Corte | Cut | Coupe E-E

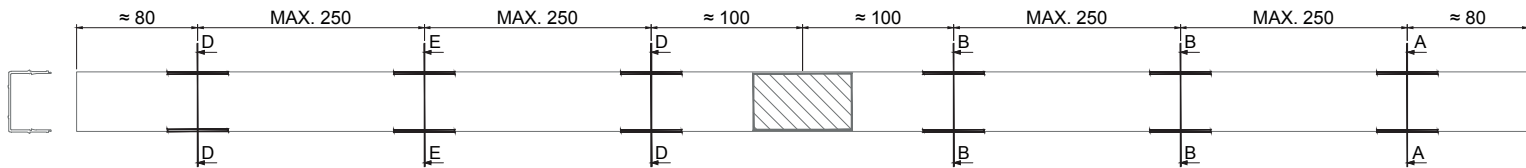
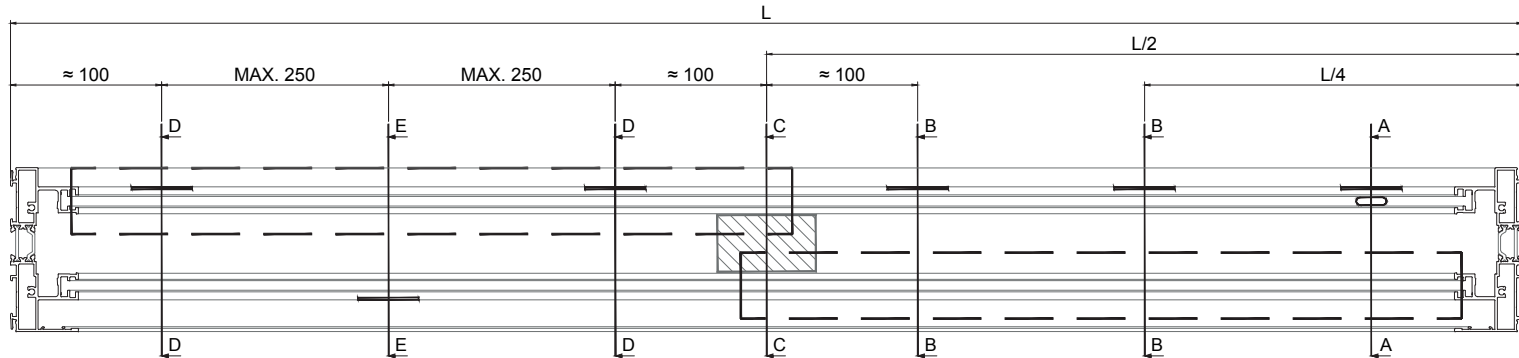

Corte | Cut | Coupe A-A  
 Corte | Cut | Coupe B-B

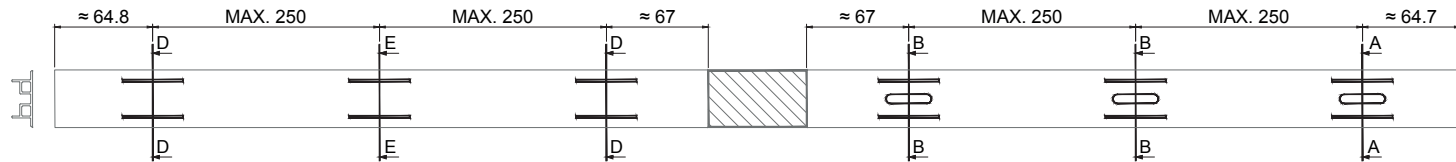
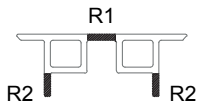

Corte | Cut | Coupe D-D  
 Corte | Cut | Coupe E-E

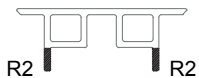

Para drenagem alternativa inferior, consultar o Departamento Técnico.  
 For alternative bottom drainage, consult the Technical Department.  
 Pour un drainage alternatif inférieur, consulter le Département Technique.



**DRENAGENS POR TIPOLOGIA**  
**DRAINAGE BY FRAME TYPOLOGY**  
**DRAINAGE PAR TYPOLOGIE**

6 - Pormenores de drenagem para os perfis de aro fixo **PT 2rail** e perfis de PVC, para tipologias de 3 folhas. **Seguir este procedimento em todos os perfis aro fixo PT 2rail.**

Drainage details of 2rail fixed **PT** frame profiles and PVC profiles, for 3 sashes typologies. **Follow this procedure in all 2rail PT fixed frame profiles.**

Détails de drainage pour profilés dormant **PT** 2rail et profilés PVC, pour les typologies à 3 vantaux. **Suivre cette procédure sur tous les profilés dormant PT 2rail.**

- R1:** Rasgo | Hole | Rainure 6x30mm
- R2:** Rasgo | Hole | Rainure 5x30mm
- R3:** Rasgo | Hole | Rainure 5x20mm
- R5:** Rasgo | Hole | Rainure 5x30mm

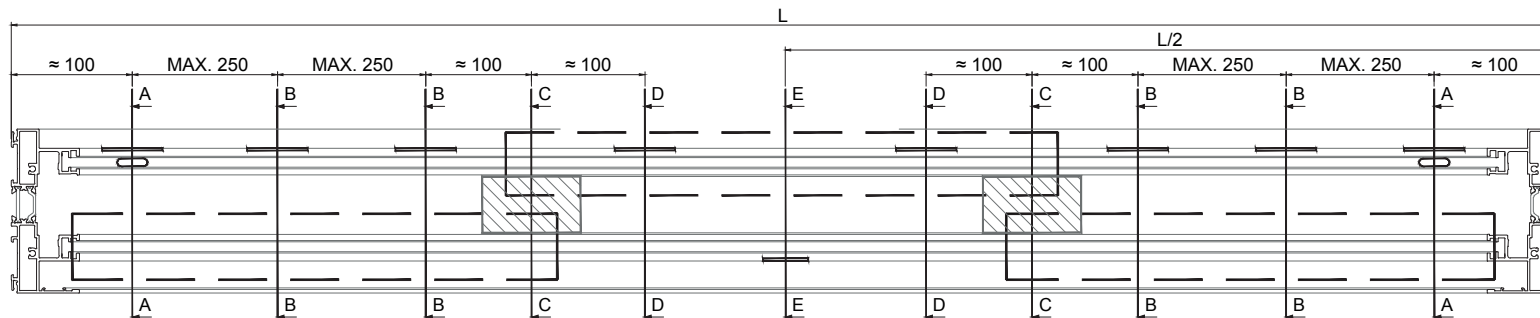
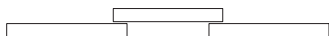
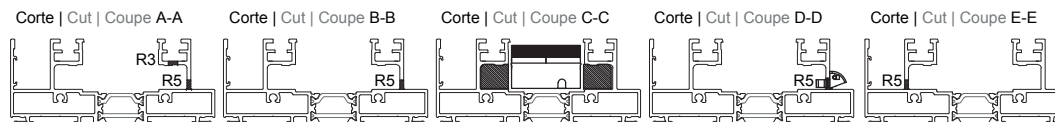
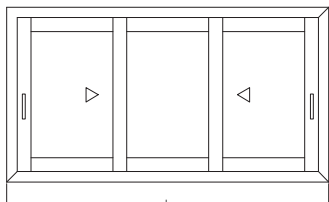

Corte | Cut | Coupe A-A  
 Corte | Cut | Coupe B-B  
 Corte | Cut | Coupe D-D  
 Corte | Cut | Coupe E-E

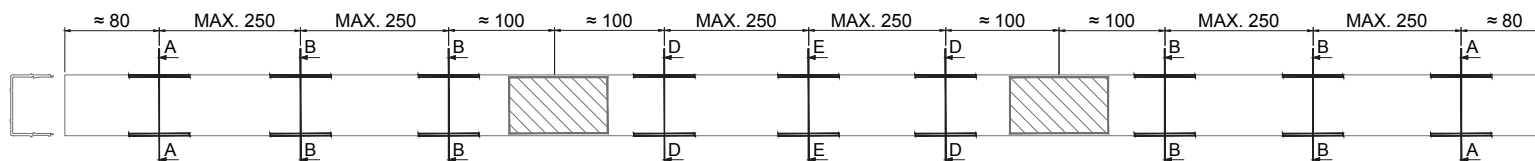

Corte | Cut | Coupe A-A  
 Corte | Cut | Coupe B-B

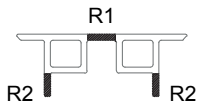

Corte | Cut | Coupe D-D  
 Corte | Cut | Coupe E-E

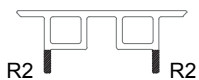

Para drenagem alternativa inferior, consultar o Departamento Técnico.  
 For alternative bottom drainage, consult the Technical Department.  
 Pour un drainage alternatif inférieur, consulter le Département Technique.





**DRENAGENS POR TIPOLOGIA**  
**DRAINAGE BY FRAME TYPOLOGY**  
**DRAINAGE PAR TYPOLOGIE**

**7 - Pormenores de drenagem para os perfis de aro fixo PT 2rail e perfis de PVC, para tipologias de 4 folhas. Seguir este procedimento em todos os perfis aro fixo PT 2rail.**  
 Drainage details of 2rail fixed PT frame profiles and PVC profiles, for 4 sashes typologies. Follow this procedure in all 2rail PT fixed frame profiles.  
 Détails de drainage pour profilés dormant PT 2rail et profilés PVC, pour les typologies à 4 vantaux. Suivre cette procédure sur tous les profilés dormant PT 2rail.

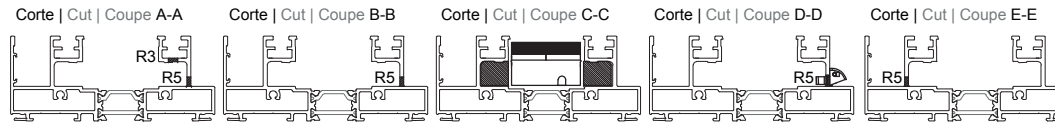
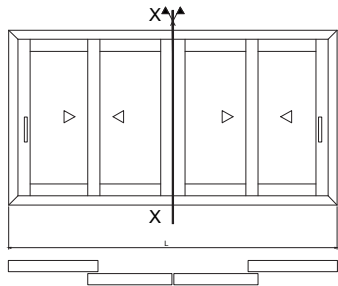

- R1:** Rasgo | Hole | Rainure 6x30mm
- R2:** Rasgo | Hole | Rainure 5x30mm
- R3:** Rasgo | Hole | Rainure 5x20mm
- R5:** Rasgo | Hole | Rainure 5x30mm

Corte | Cut | Coupe A-A  
 Corte | Cut | Coupe B-B  
 Corte | Cut | Coupe D-D  
 Corte | Cut | Coupe E-E

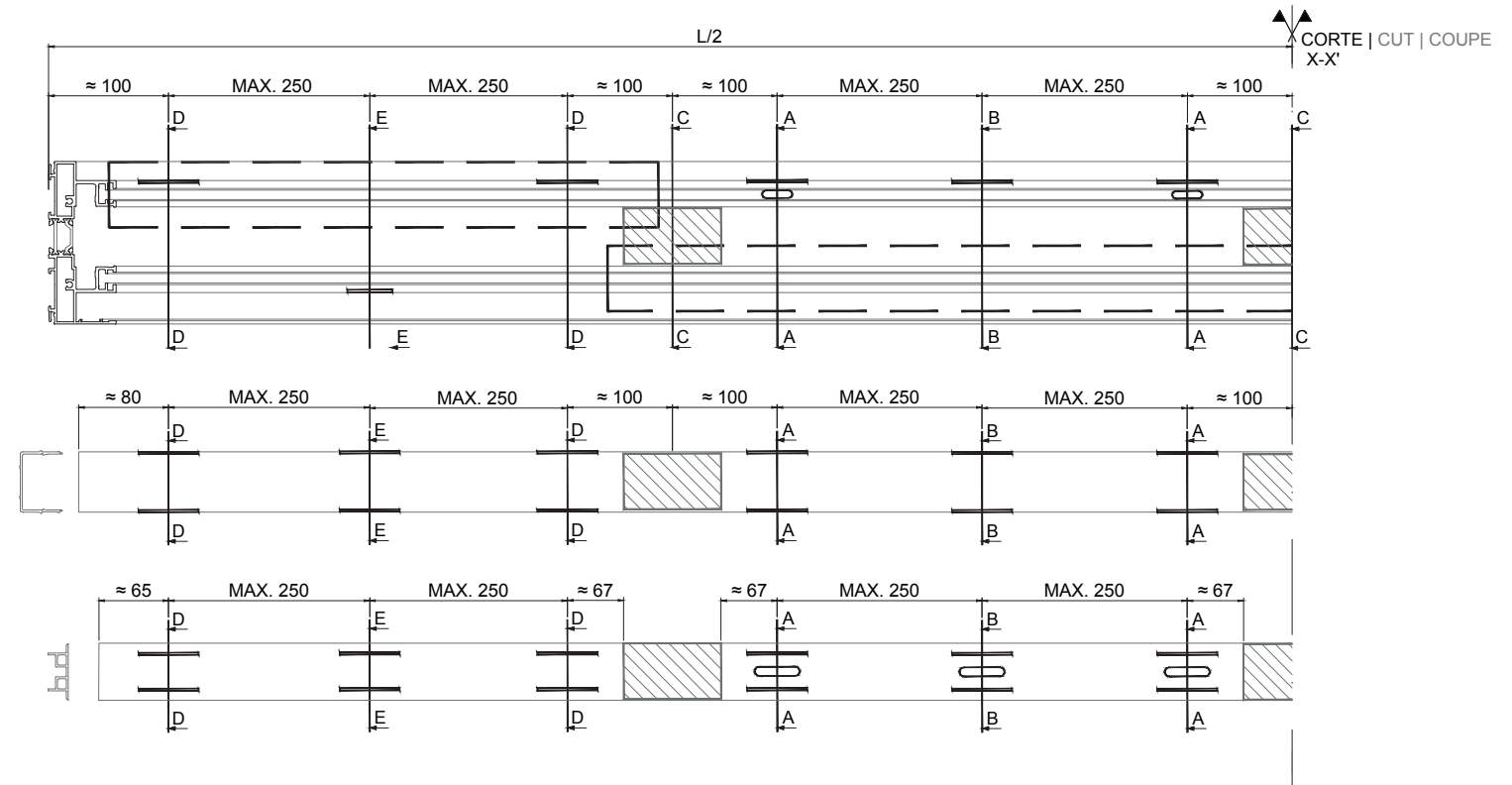
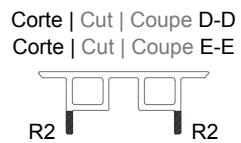
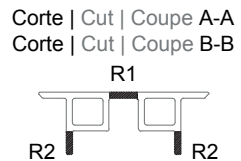

Para drenagem alternativa inferior, consultar o Departamento Técnico.  
 For alternative bottom drainage, consult the Technical Department.  
 Pour un drainage alternatif inférieur, consulter le Département Technique.



# DRENAGENS POR TIPOLOGIA

## DRAINAGE BY FRAME TYPOLOGY

### DRAINAGE PAR TYPOLOGIE

#### 8 - Pormenores de drenagem para os perfis de aro fixo PT 3rail e perfis de PVC, para tipologias de 3 folhas.

Drainage details of fixed 3rail PT frame profiles and PVC profiles, for 3 sashes typologies.  
 Détails de drainage pour profilés dormant PT 3rail et profilés PVC, pour les typologies à 3 vantaux.

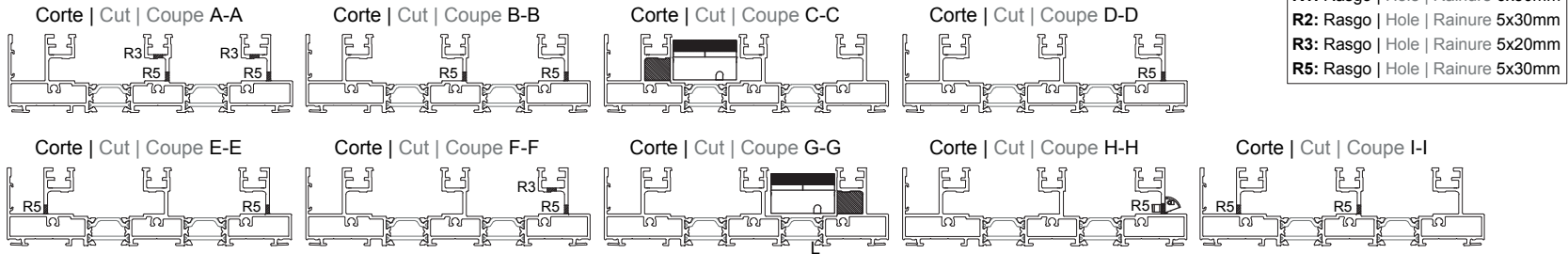
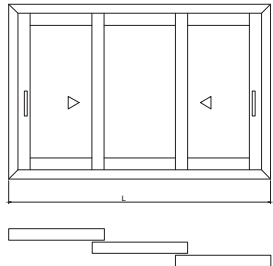

**R1:** Rasgo | Hole | Rainure 6x30mm  
**R2:** Rasgo | Hole | Rainure 5x30mm  
**R3:** Rasgo | Hole | Rainure 5x20mm  
**R5:** Rasgo | Hole | Rainure 5x30mm

Cortes | Cuts | Coupes A-A | B-B  
 Cortes | Cuts | Coupes D-D | F-F  
 Cortes | Cuts | Coupes H-H | I-I



Cortes | Cuts | Coupes A-A | B-B  
 Cortes | Cuts | Coupes D-D | F-F

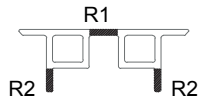

Cortes | Cuts | Coupes H-H | I-I

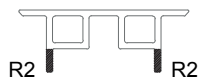

Para drenagem alternativa inferior, consultar o Departamento Técnico.  
 For alternative bottom drainage, consult the Technical Department.  
 Pour un drainage alternatif inférieur, consulter le Département Technique.

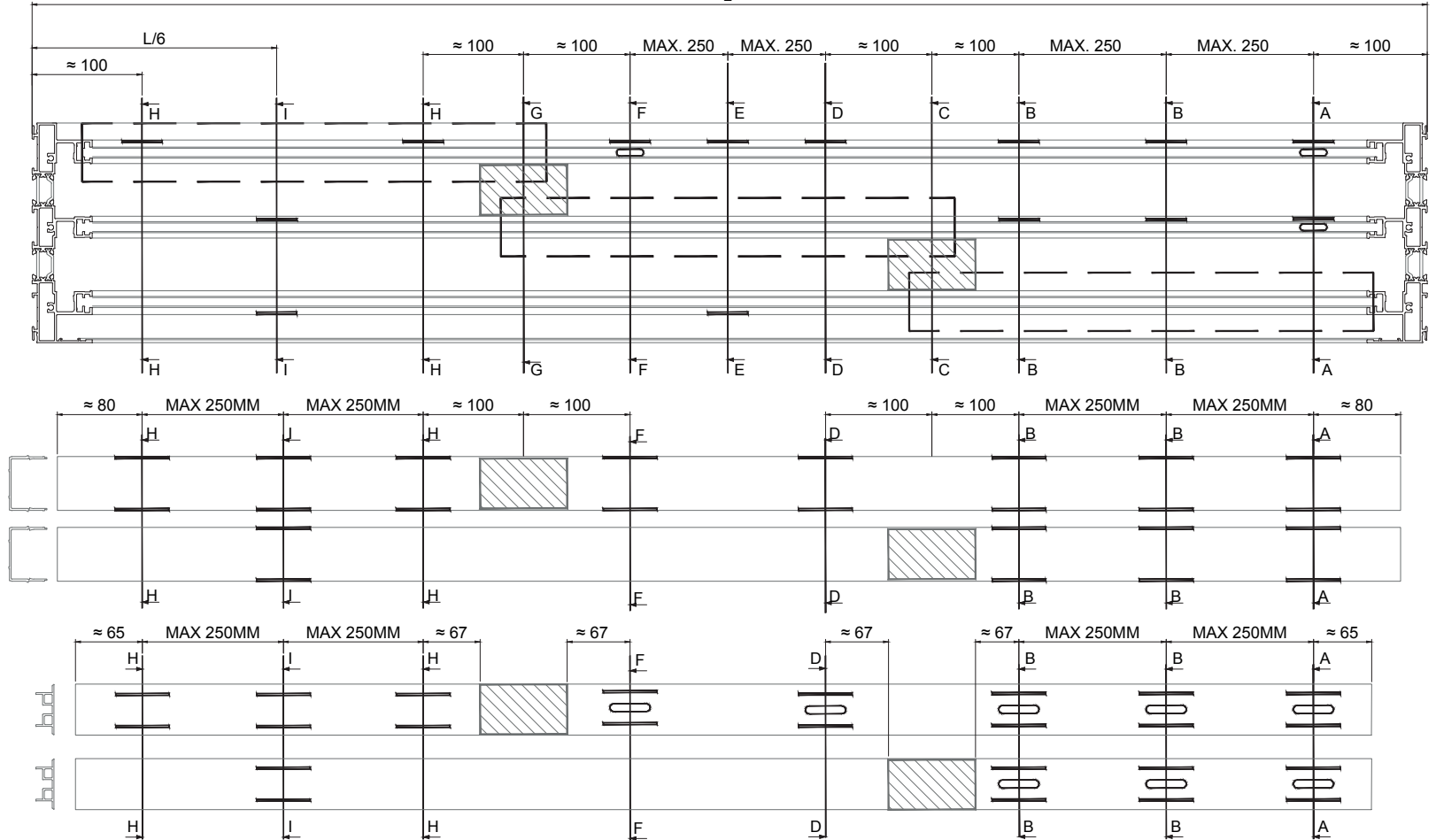
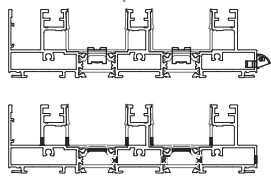

**DRENAGENS POR TIPOLOGIA**  
**DRAINAGE BY FRAME TYPOLOGY**  
**DRAINAGE PAR TYPOLOGIE**

9 - Pormenores de drenagem para os perfis de aro fixo **PT 4rail** e perfis de PVC, para tipologias de 4 folhas.  
 Drainage details of fixed 4rail **PT** frame profiles and PVC profiles, for 4 sashes typologies.  
 Détails de drainage pour profilés dormant **PT** 4rail et profilés PVC, pour les typologies à 4 vantaux.

**R1:** Rasgo | Hole | Rainure 6x30mm  
**R2:** Rasgo | Hole | Rainure 5x30mm  
**R3:** Rasgo | Hole | Rainure 5x20mm  
**R5:** Rasgo | Hole | Rainure 5x30mm

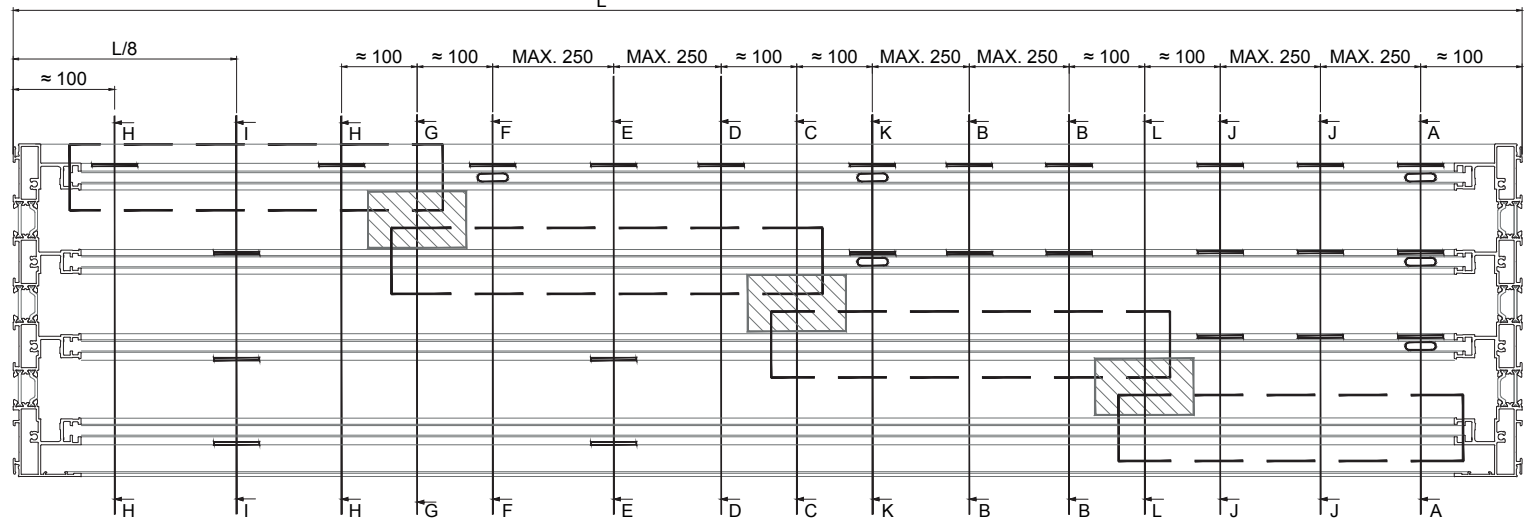
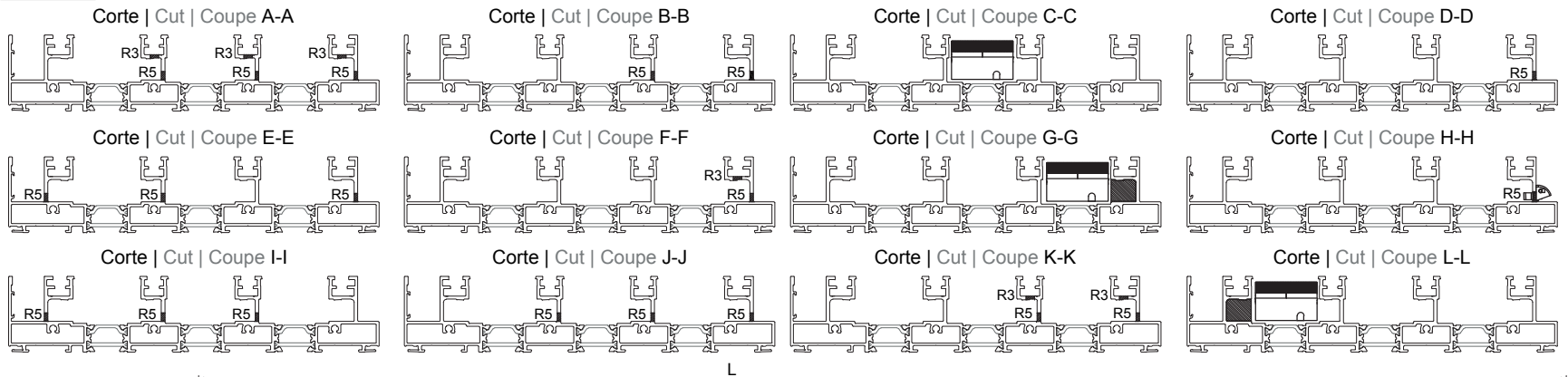
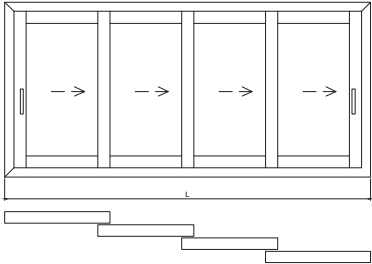

Para drenagem alternativa inferior, consultar o Departamento Técnico.  
 For alternative bottom drainage, consult the Technical Department.  
 Pour un drainage alternatif inférieur, consulter le Département Technique.

**DRENAGENS POR TIPOLOGIA**  
**DRAINAGE BY FRAME TYPOLOGY**  
**DRAINAGE PAR TYPOLOGIE**

9 - Pormenores de drenagem para os perfis de aro fixo **PT 4rail** e perfis de PVC, para tipologias de 4 folhas.  
 Drainage details of fixed 4rail **PT** frame profiles and PVC profiles, for 4 sashes typologies.  
 Détails de drainage pour profilés dormant **PT** 4rail et profilés PVC, pour les typologies à 4 vantaux.

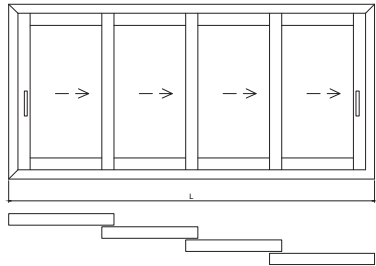

Corte | Cut | Coupe A-A    Corte | Cut | Coupe F-F  
 Corte | Cut | Coupe B-B    Corte | Cut | Coupe I-I  
 Corte | Cut | Coupe D-D    Corte | Cut | Coupe H-H



Corte | Cut | Coupe A-A  
 Corte | Cut | Coupe B-B  
 Corte | Cut | Coupe D-D  
 Corte | Cut | Coupe F-F

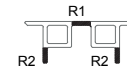

Corte | Cut | Coupe H-H  
 Corte | Cut | Coupe I-I



**R1:** Rasgo | Hole | Rainure 6x30mm  
**R2:** Rasgo | Hole | Rainure 5x30mm  
**R3:** Rasgo | Hole | Rainure 5x20mm  
**R5:** Rasgo | Hole | Rainure 5x30mm

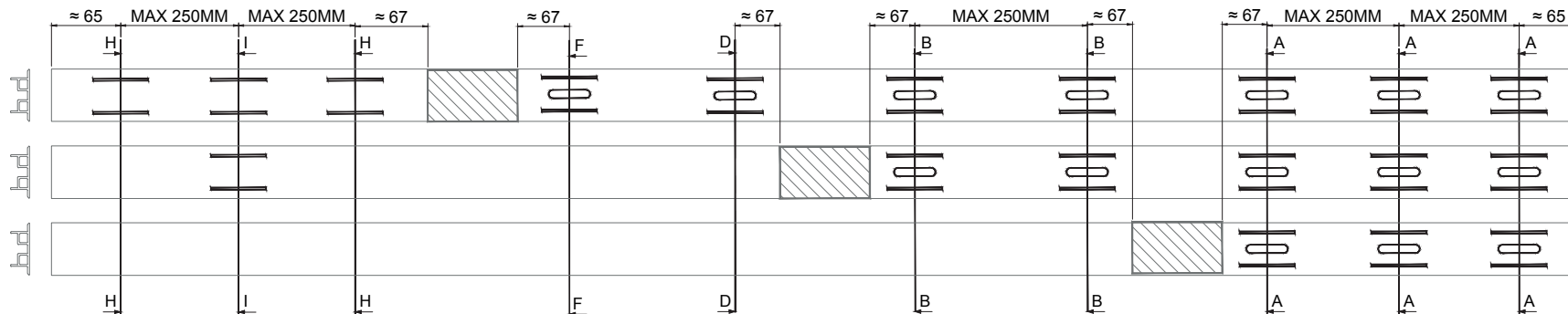
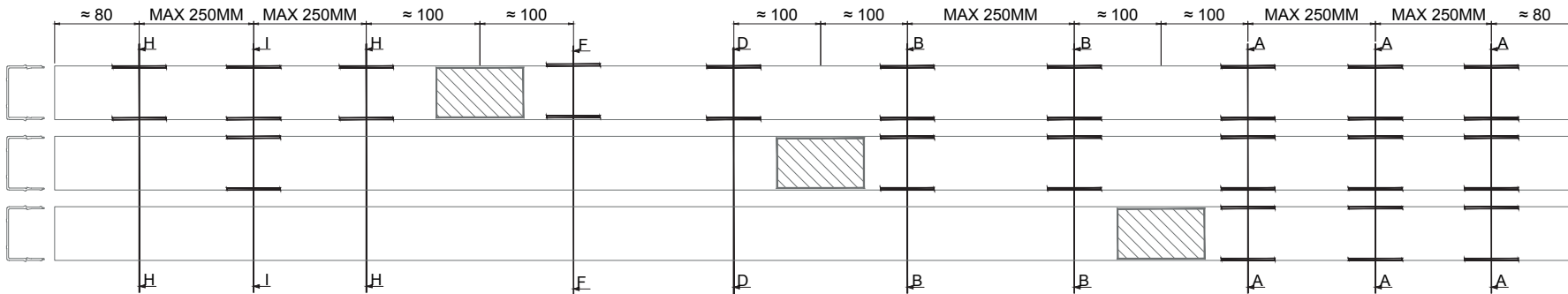

**DRENAGENS POR TIPOLOGIA**  
**DRAINAGE BY FRAME TYPOLOGY**  
**DRAINAGE PAR TYPOLOGIE**

**10 - Pormenores de drenagem para perfil soleira 30mm 2rail e perfil poliamida, para tipologias de 2 folhas.**  
 Drainage details of 2rail 30mm sill profile and polyamide profile, for 2 sashes typologies.  
 Détails de drainage pour seuil profilé 30mm 2rail et profilé polyamide, pour les typologies à 2 vantaux.

**R5:** Rasgo | Hole | Rainure 5x30mm  
**R8:** Rasgo | Hole | Rainure 6x30mm  
**R9:** Rasgo | Hole | Rainure 6x30mm  
**R10:** Rasgo | Hole | Rainure 4x25mm  
**R11:** Rasgo | Hole | Rainure 5x40mm

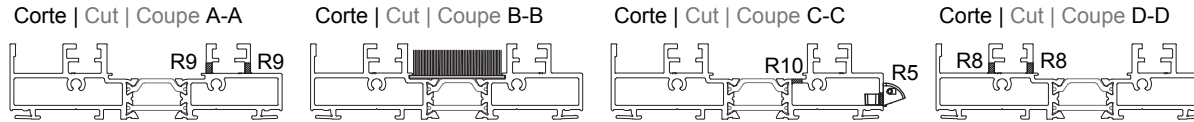
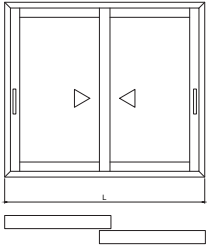

**10.1 - Com goteira frontal SV-E.**  
 With SV-E frontal drip.  
 Avec gouttière avant SV-E.

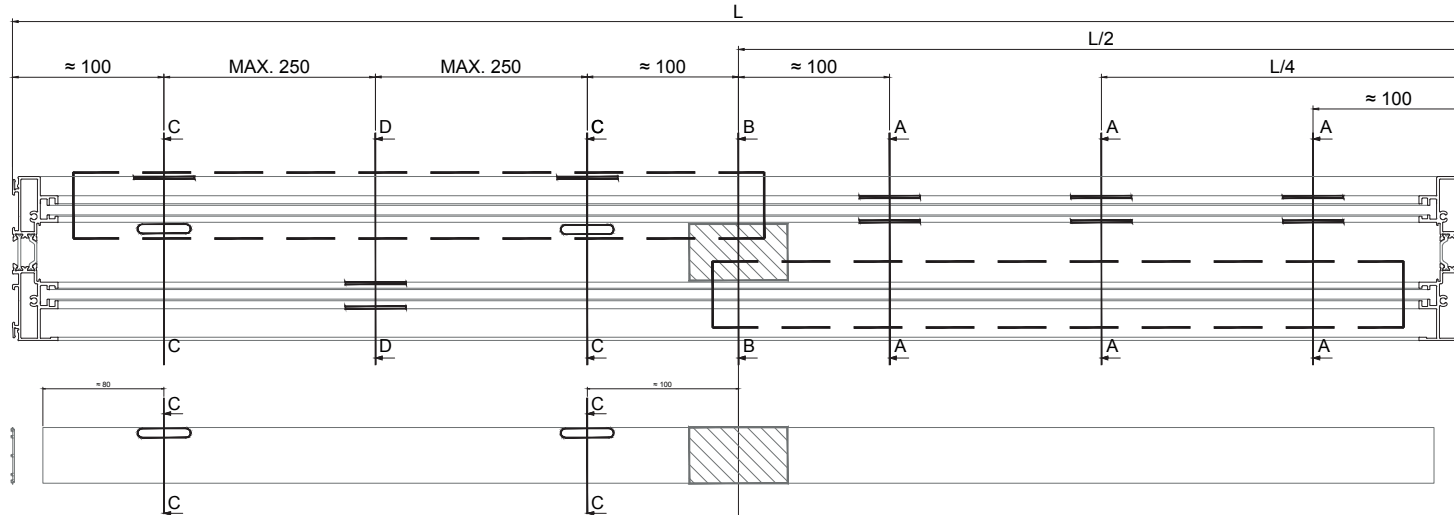

Corte | Cut | Coupe C-C



**10.2 - Sem goteira frontal SV-E.**  
 Without SV-E frontal drip.  
 Sans gouttière avant SV-E.

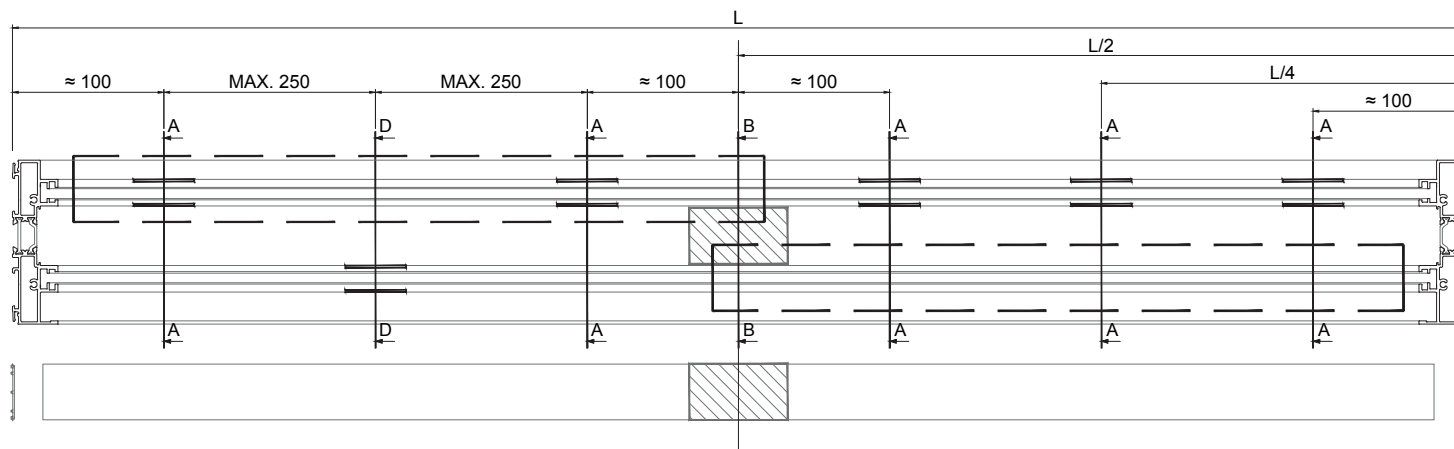

**Para caixilhos abrigados da chuva**  
 For frames sheltered from the rain  
 Pour les cadres à l'abri de la pluie

**DRENAGENS POR TIPOLOGIA**  
**DRAINAGE BY FRAME TYPOLOGY**  
**DRAINAGE PAR TYPOLOGIE**

**11 - Pormenores de drenagem para o perfil soleira 30mm 2rail e perfil poliamida, para tipologias de 3 folhas.**  
 Drainage details of 2rail 30mm sill profile and polyamide profile, for 3 sashes typologies.  
 Détails de drainage pour seuil profilé 30mm 2rail et profilé polyamide, pour les typologies à 3 vantaux.

- R5:** Rasgo | Hole | Rainure 5x30mm
- R8:** Rasgo | Hole | Rainure 6x30mm
- R9:** Rasgo | Hole | Rainure 6x30mm
- R10:** Rasgo | Hole | Rainure 4x25mm
- R11:** Rasgo | Hole | Rainure 5x40mm

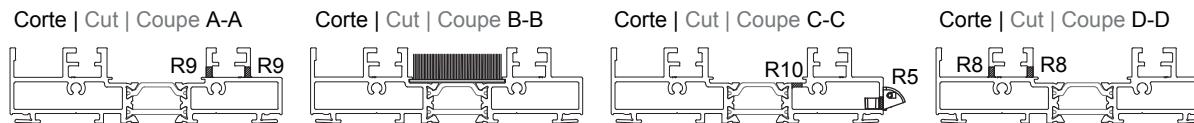
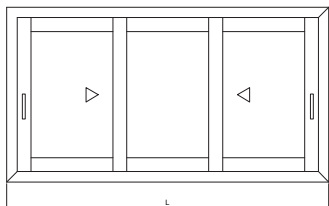

**11.1 - Com goteira frontal SV-E.**  
 With SV-E frontal drip.  
 Avec gouttière avant SV-E.

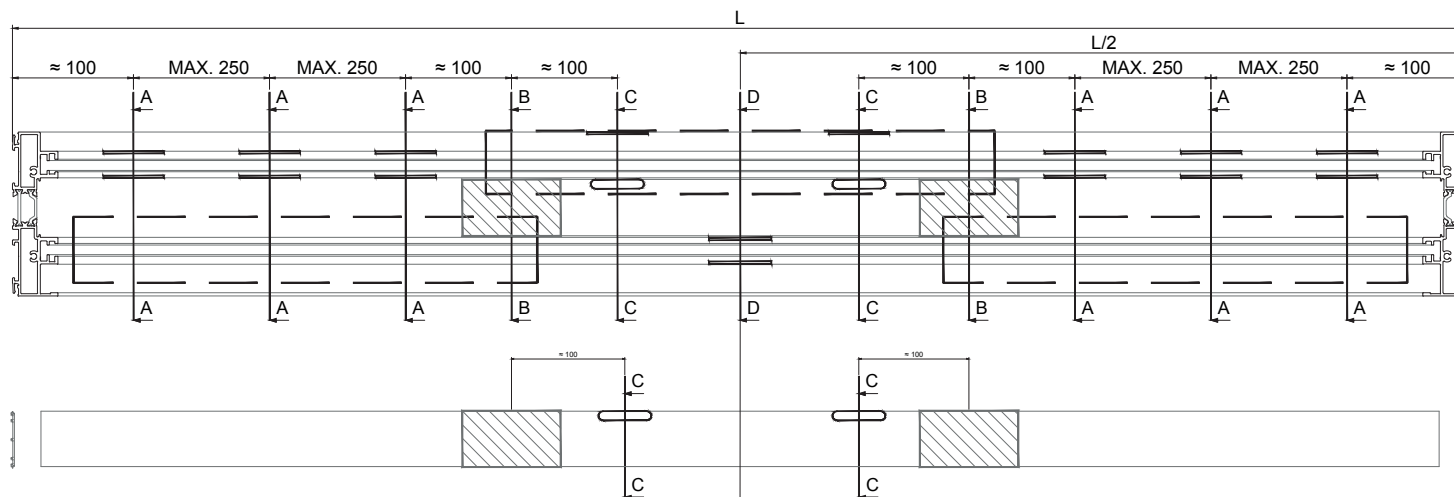

Corte | Cut | Coupe C-C



**11.2 - Sem goteira frontal SV-E.**  
 Without SV-E frontal drip.  
 Sans gouttière avant SV-E.

**Para caixilhos abrigados da chuva**  
 For frames sheltered from the rain  
 Pour les cadres à l'abri de la pluie

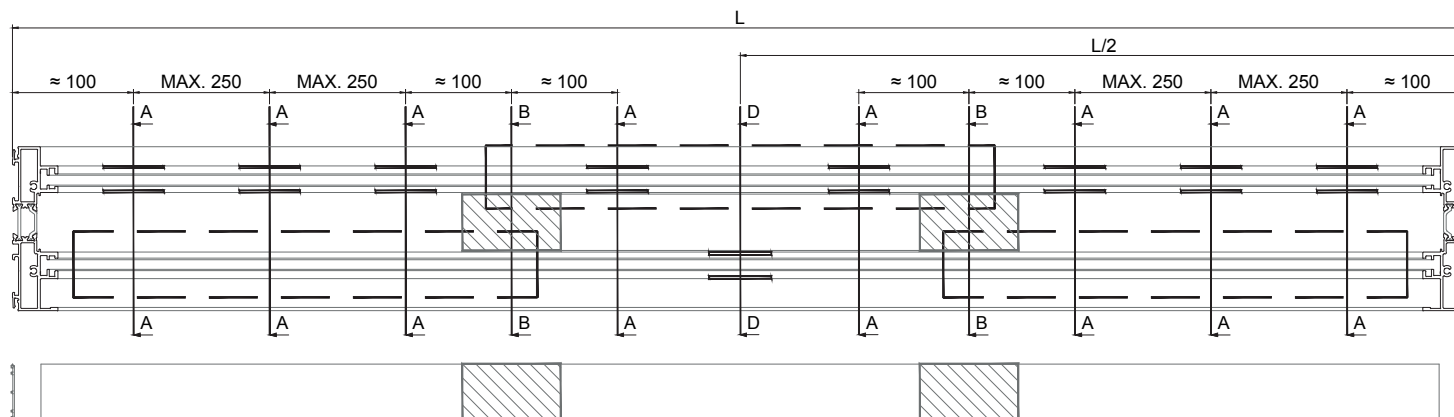



**DRENAGENS POR TIPOLOGIA**  
**DRAINAGE BY FRAME TYPOLOGY**  
**DRAINAGE PAR TYPOLOGIE**

**12 - Pormenores de drenagem para o perfil soleira 30mm 2rail e perfil poliamida, para tipologias de 4 folhas.**  
 Drainage details of 2rail 30mm sill profile and polyamide profile, for 4 sashes typologies.  
 Détails de drainage pour seuil profilé 30mm 2rail et profilé polyamide, pour les typologies à 4 vantaux.

**R5:** Rasgo | Hole | Rainure 5x30mm  
**R8:** Rasgo | Hole | Rainure 6x30mm  
**R9:** Rasgo | Hole | Rainure 6x30mm  
**R10:** Rasgo | Hole | Rainure 4x25mm  
**R11:** Rasgo | Hole | Rainure 5x40mm

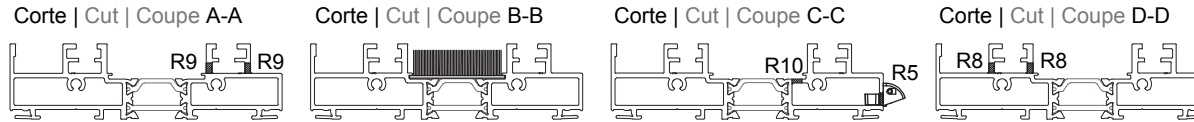
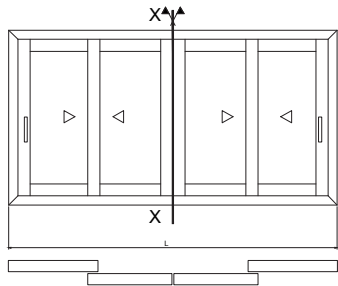

**12.1 - Com goteira frontal SV-E.**  
 With SV-E frontal drip.  
 Avec gouttière avant SV-E.

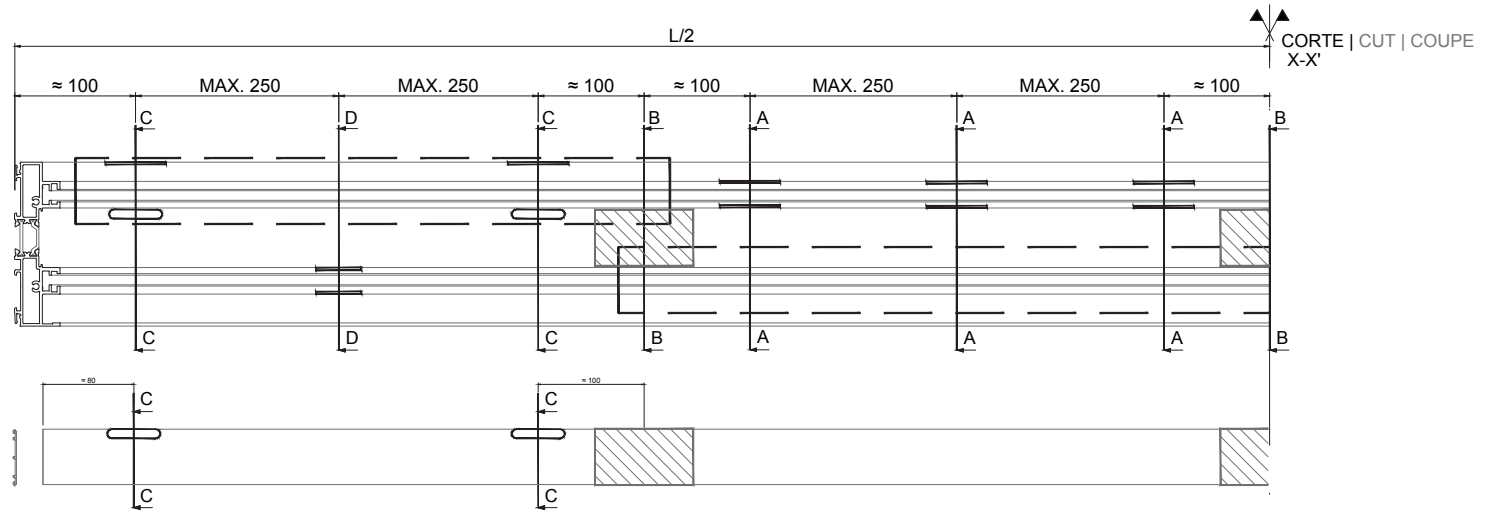

Corte | Cut | Coupe C-C



**12.2 - Sem goteira frontal SV-E.**  
 Without SV-E frontal drip.  
 Sans gouttière avant SV-E.

**Para caixilhos abrigados da chuva**  
 For frames sheltered from the rain  
 Pour les cadres à l'abri de la pluie

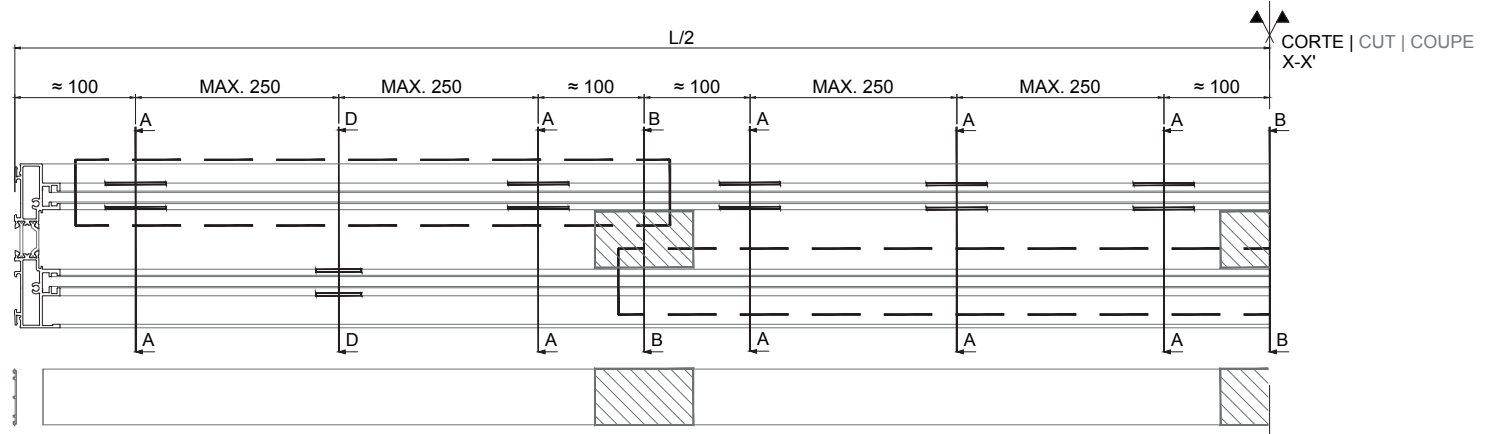

**DRENAGENS POR TIPOLOGIA**  
**DRAINAGE BY FRAME TYPOLOGY**  
**DRAINAGE PAR TYPOLOGIE**

**13 - Pormenores de drenagem para o perfil soleira 30mm 3rail e perfis poliamida, para tipologias de 3 folhas.**  
 Drainage details of 3rail 30mm sill profile and polyamide profiles, for 3 sashes typologies.  
 Détails de drainage pour seuil profilé 30mm 3rail et profilés polyamide, pour les typologies à 3 vantaux.

- R5:** Rasgo | Hole | Rainure 5x30mm
- R8:** Rasgo | Hole | Rainure 6x30mm
- R9:** Rasgo | Hole | Rainure 6x30mm
- R10:** Rasgo | Hole | Rainure 4x25mm
- R11:** Rasgo | Hole | Rainure 5x40mm

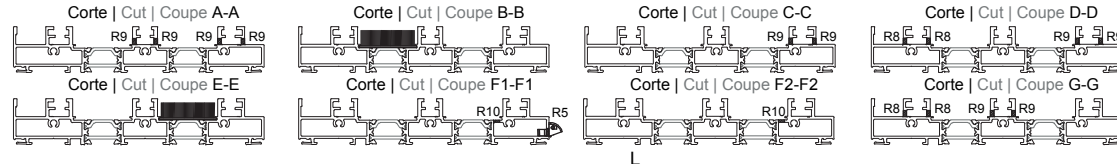
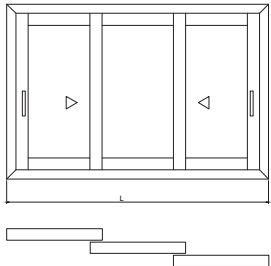

**13.1 - Com goteira frontal SV-E.**  
 With SV-E frontal drip.  
 Avec gouttière avant SV-E.

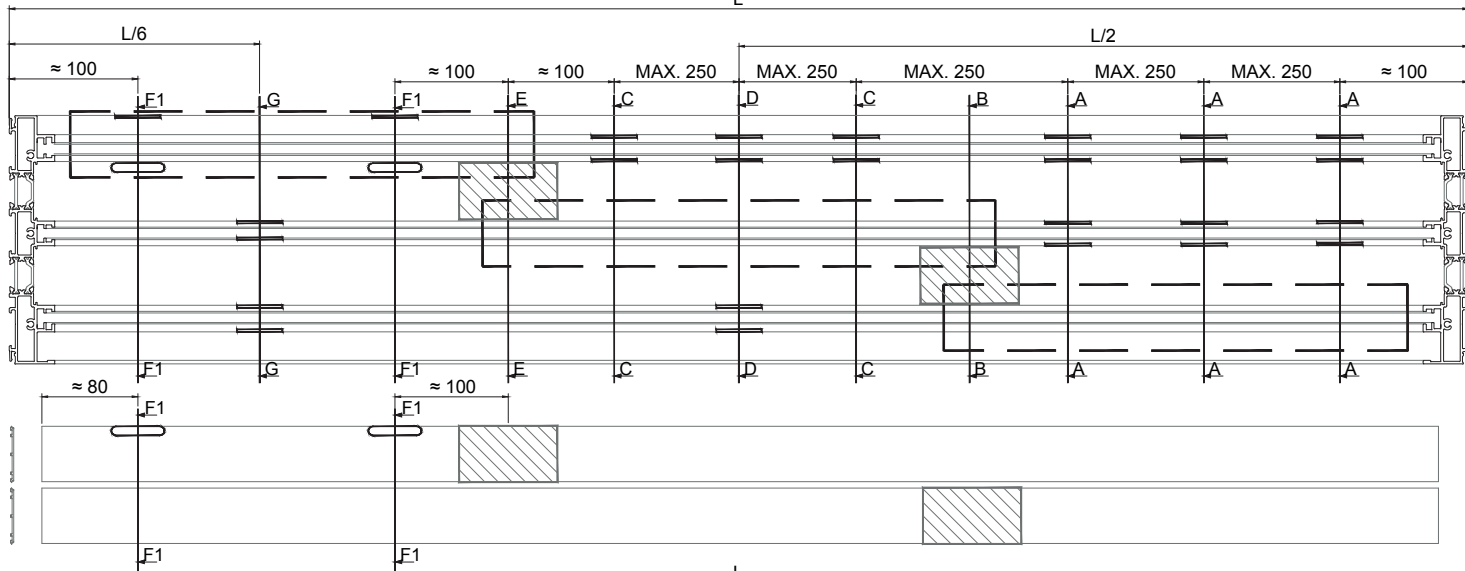

Corte | Cut | Coupe F1-F1



**13.2 - Sem goteira frontal SV-E.**  
 Without SV-E frontal drip.  
 Sans gouttière avant SV-E.

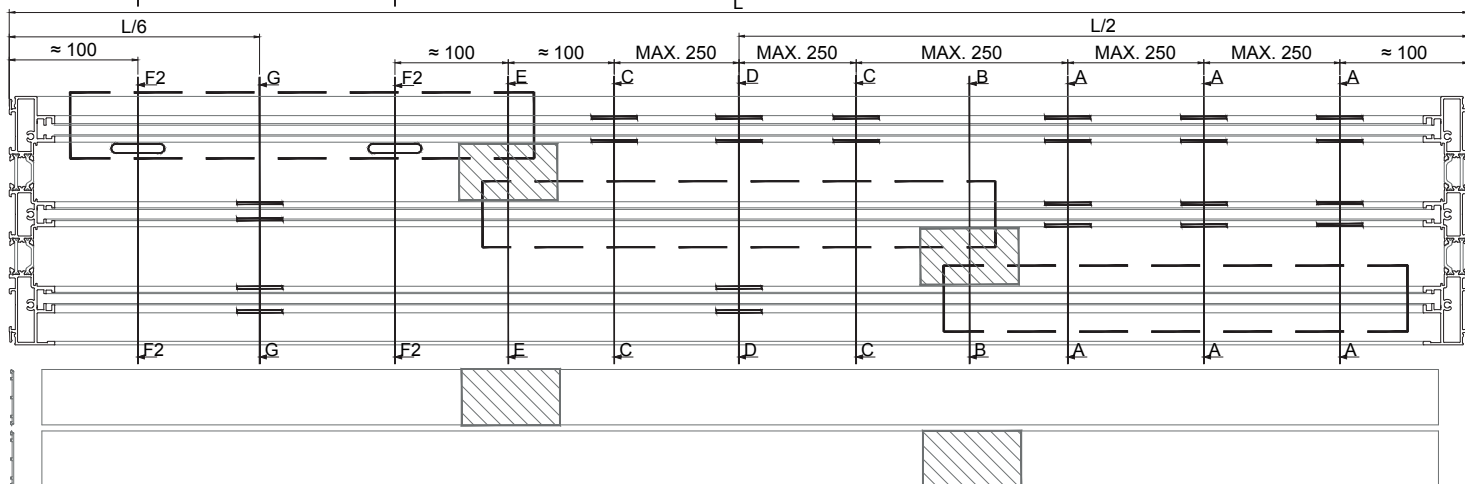

**Para caixilhos abrigados da chuva**  
 For frames sheltered from the rain  
 Pour les cadres à l'abri de la pluie

**DRENAGENS POR TIPOLOGIA**  
**DRAINAGE BY FRAME TYPOLOGY**  
**DRAINAGE PAR TIPOLOGIE**

**14 - Pormenores de drenagem para o perfil soleira 30mm 4rail e perfis poliamida, para tipologias de 4 folhas.**  
 Drainage details of 4rail 30mm sill profile and polyamide profiles, for 4 sashes typologies.  
 Détails de drainage pour seuil profilé 30mm 4rail et profilés polyamide, pour les typologies à 4 vantaux.

- R5:** Rasgo | Hole | Rainure 5x30mm
- R8:** Rasgo | Hole | Rainure 6x30mm
- R9:** Rasgo | Hole | Rainure 6x30mm
- R10:** Rasgo | Hole | Rainure 4x25mm
- R11:** Rasgo | Hole | Rainure 5x40mm

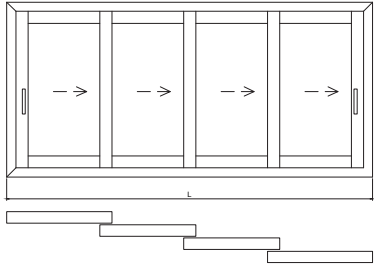

**14.1 - Com goteira frontal SV-E.**  
 With SV-E frontal drip.  
 Avec gouttière avant SV-E.

Corte | Cut | Coupe F-F



Corte | Cut | Coupe A-A



Corte | Cut | Coupe B-B

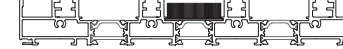

Corte | Cut | Coupe C-C



Corte | Cut | Coupe D-D

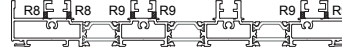

Corte | Cut | Coupe E-E

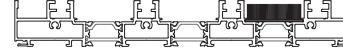

Corte | Cut | Coupe F-F

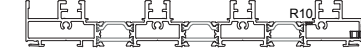

Corte | Cut | Coupe G-G

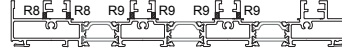

Corte | Cut | Coupe H-H

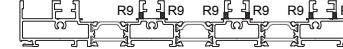

Corte | Cut | Coupe I-I

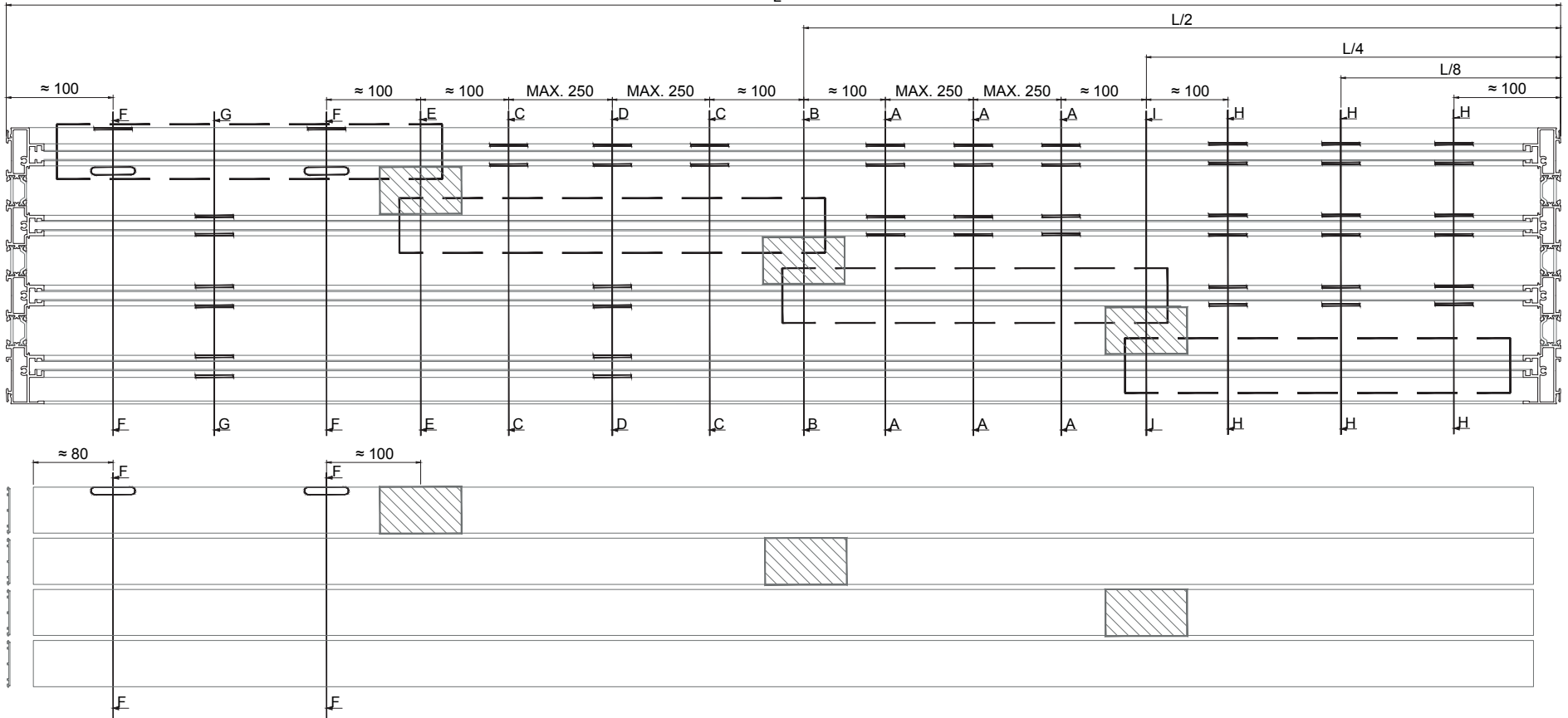
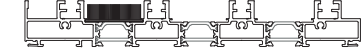

**DRENAGENS POR TIPOLOGIA**  
**DRAINAGE BY FRAME TYPOLOGY**  
**DRAINAGE PAR TYPOLOGIE**

**14 - Pormenores de drenagem para o perfil soleira 30mm 4rail e perfis poliamida, para tipologias de 4 folhas.**  
 Drainage details of 4rail 30mm sill profile and polyamide profiles, for 4 sashes typologies.  
 Détails de drainage pour seuil profilé 30mm 4rail et profilés polyamide, pour les typologies à 4 vantaux.

- R5:** Rasgo | Hole | Rainure 5x30mm
- R8:** Rasgo | Hole | Rainure 6x30mm
- R9:** Rasgo | Hole | Rainure 6x30mm
- R10:** Rasgo | Hole | Rainure 4x25mm
- R11:** Rasgo | Hole | Rainure 5x40mm

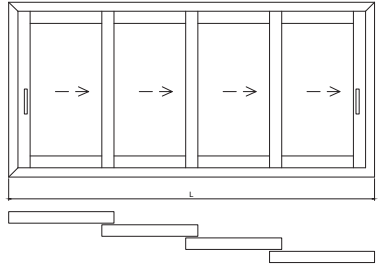

**14.2 - Sem goteira frontal SV-E.**  
 Without SV-E frontal drip.  
 Sans gouttière avant SV-E.

**Para caixilhos abrigados da chuva**  
 For frames sheltered from the rain  
 Pour les cadres à l'abri de la pluie

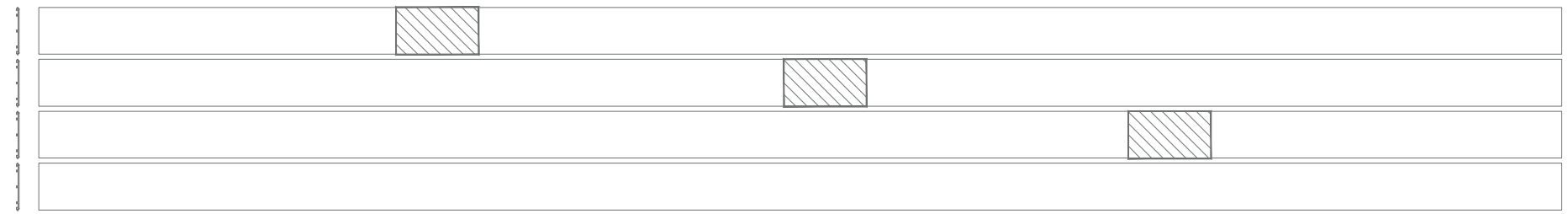
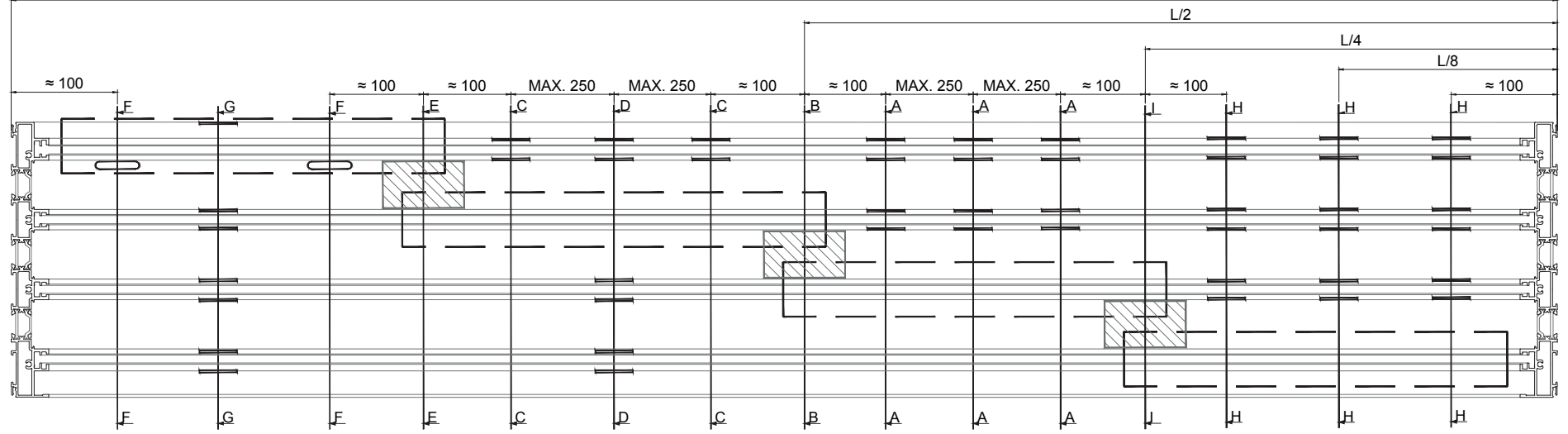
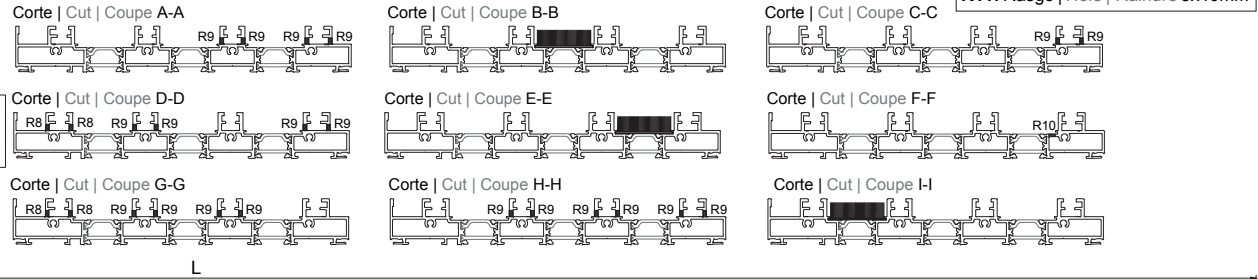

**DRENAGENS POR TIPOLOGIA**  
**DRAINAGE BY FRAME TYPOLOGY**  
**DRAINAGE PAR TYPOLOGIE**

**15 - Pormenores de drenagem para os perfis de aro fixo JT 15.**  
 Drainage details for JT 15 frame profiles.  
 Détails de drainage pour profilés dormant JT 15.

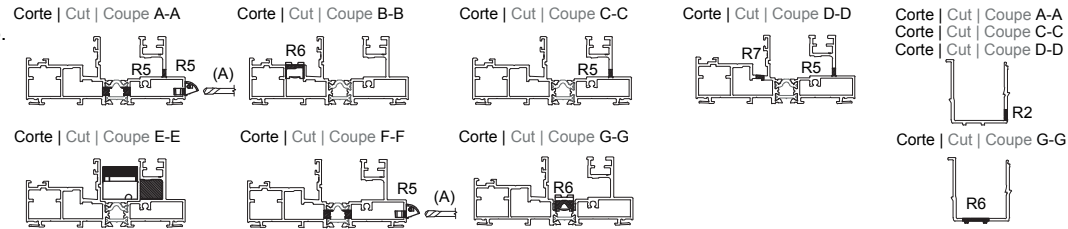

**15.1 - Tipologias de 1 folha móvel + 1 fixo.**  
 1 mobile sash + 1 fixed typologies.  
 Typologies à 1 vantail coulissant + fixe.

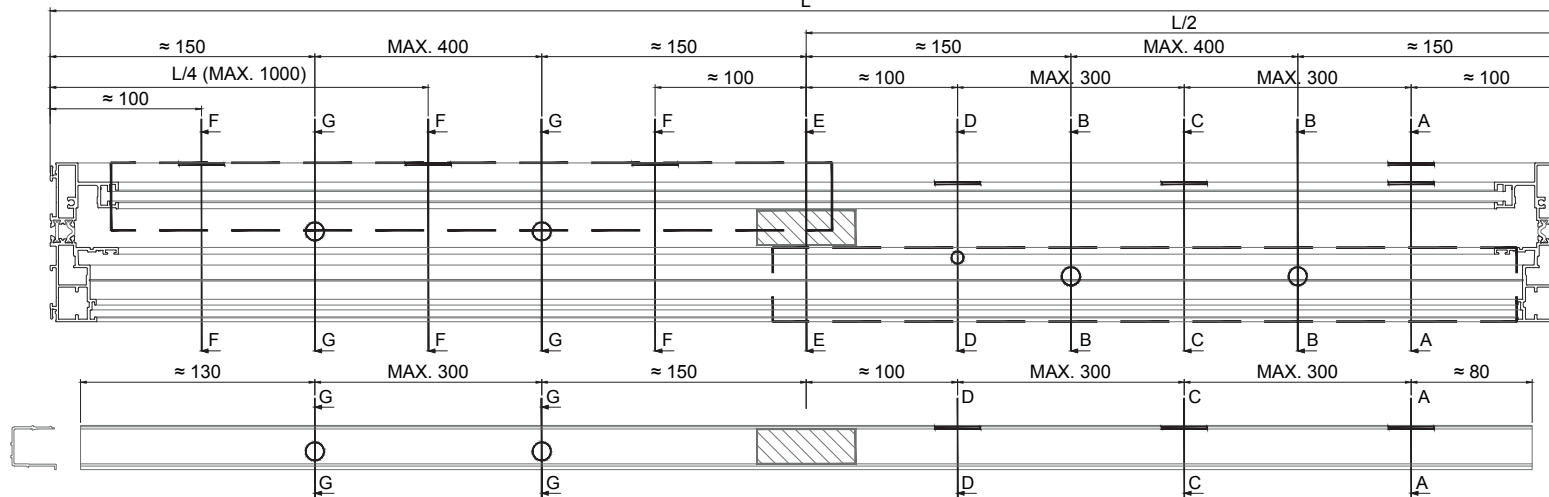

**15.2 - Tipologias de 2 folhas móveis + 1 fixo.**  
 2 mobile sashes + 1 fixed typologies.  
 Typologies à 2 vantaux coulissants + fixe.

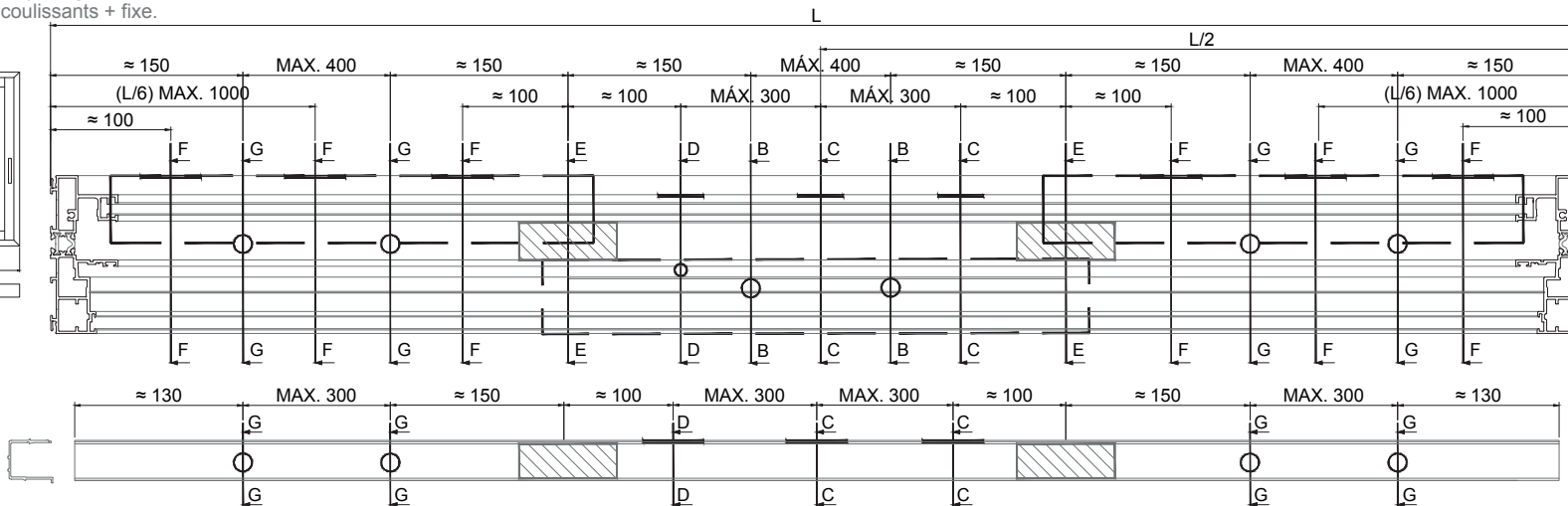
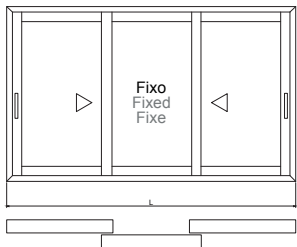

**DRENAGENS POR TIPOLOGIA**  
**DRAINAGE BY FRAME TYPOLOGY**  
**DRAINAGE PAR TYPOLOGIE**

**16 - Pormenores de drenagem para os perfis de aro fixo JT 25, para tipologias de 2 folhas móveis + 1 fixo.**  
 Drainage details for JT 25 frame profiles, for 2 mobile sashes + 1 fixed typologies.  
 Détails de drainage pour profilés dormant JT 25, pour les typologies à 2 vantaux coulissants + fixe.

(A) Rasgo realizado com fresa 5mm  
 Hole made by 5mm milling machine  
 Rainure réalisée avec machine de fraiseage 5mm

- R1:** Rasgo | Hole | Rainure 6x30mm
- R2:** Rasgo | Hole | Rainure 5x30mm
- R3:** Rasgo | Hole | Rainure 5x20mm
- R5:** Rasgo | Hole | Rainure 5x30mm
- R6:** Furo | Hole | Trou Ø12mm
- R7:** Furo | Hole | Trou Ø8mm

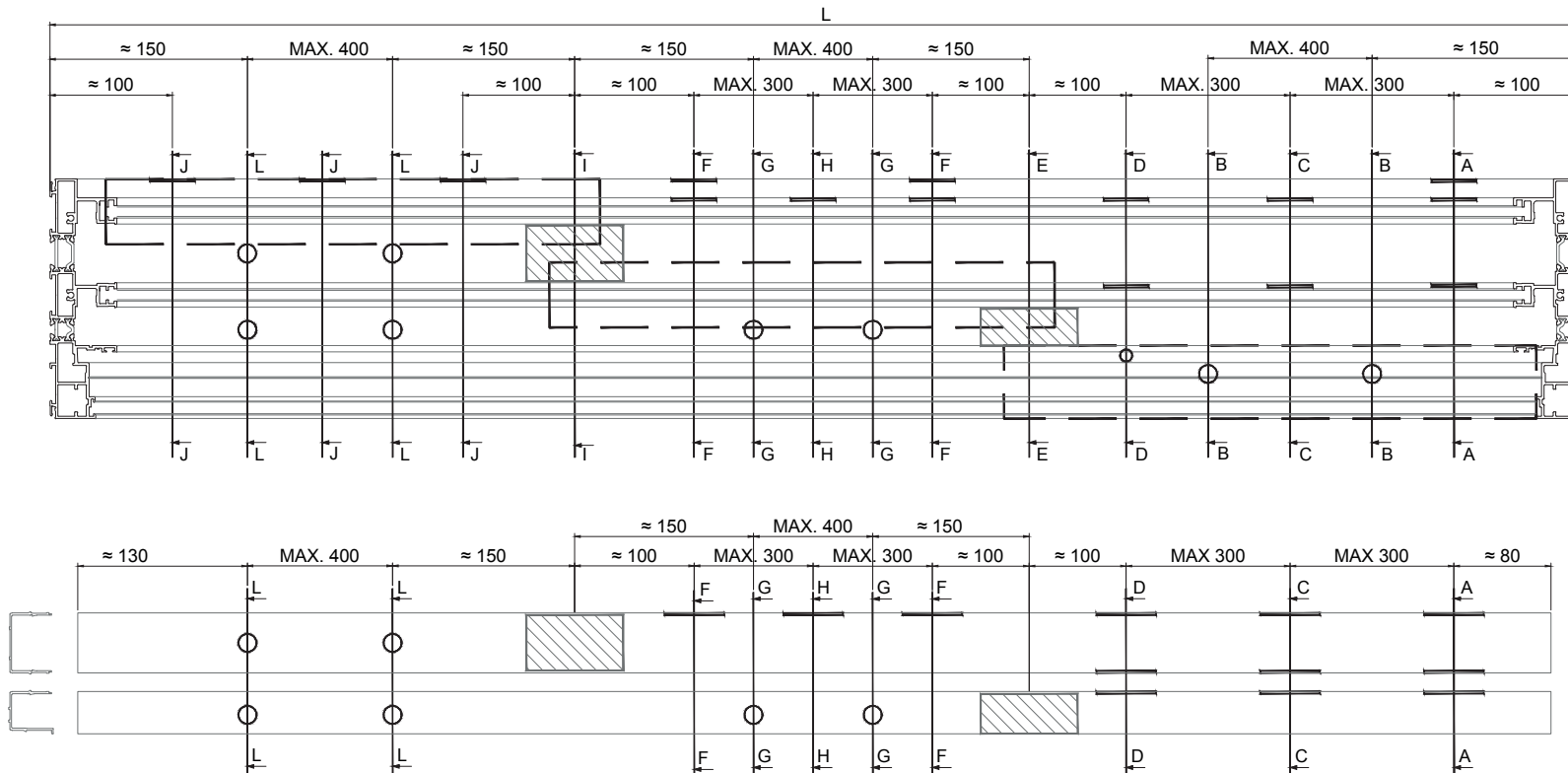
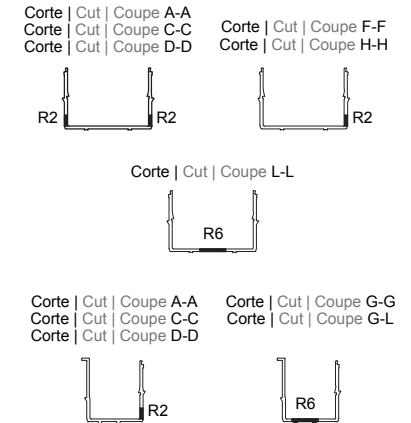
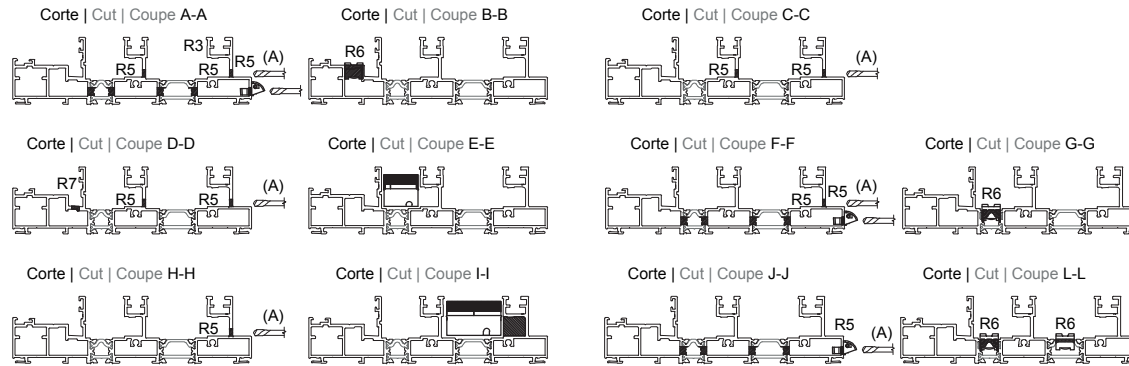



**DRENAGENS POR TIPOLOGIA**  
**DRAINAGE BY FRAME TYPOLOGY**  
**DRAINAGE PAR TYPOLOGIE**

**17 - Pormenores de drenagem para os perfis de aro fixo JT 16.**  
 Drainage details for JT 16 frame profiles.  
 Détails de drainage pour profilés dormant JT 16.

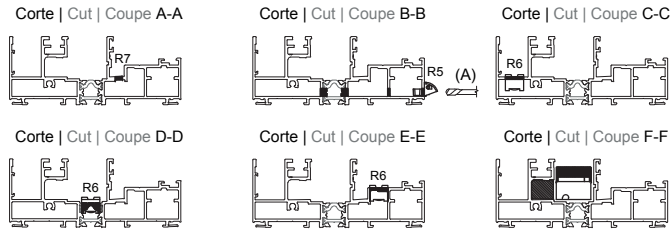

**17.1 - Tipologias de 1 folha móvel + 1 fixo.**  
 1 mobile sash + 1 fixed typologies.  
 Typologies à 1 vantail coulissant + fixe.

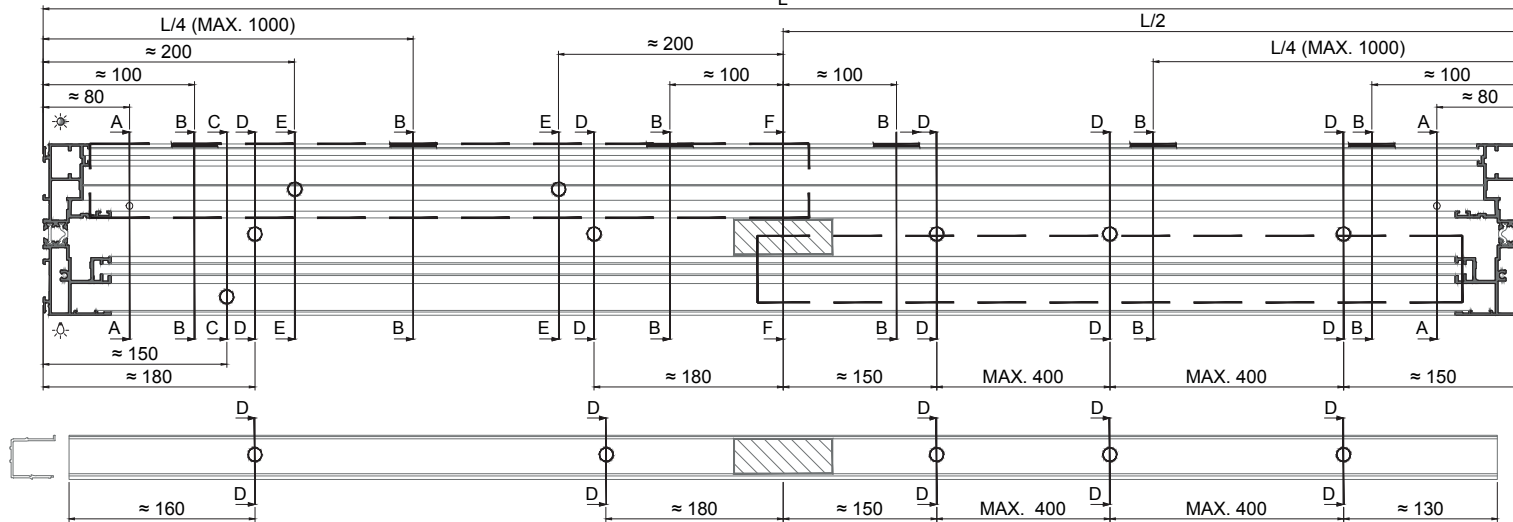

**17.2 - Tipologias de 2 folhas móveis + 1 fixo.**  
 2 mobile sashes + 1 fixed typologies.  
 Typologies à 2 vantaux coulissants + fixe.

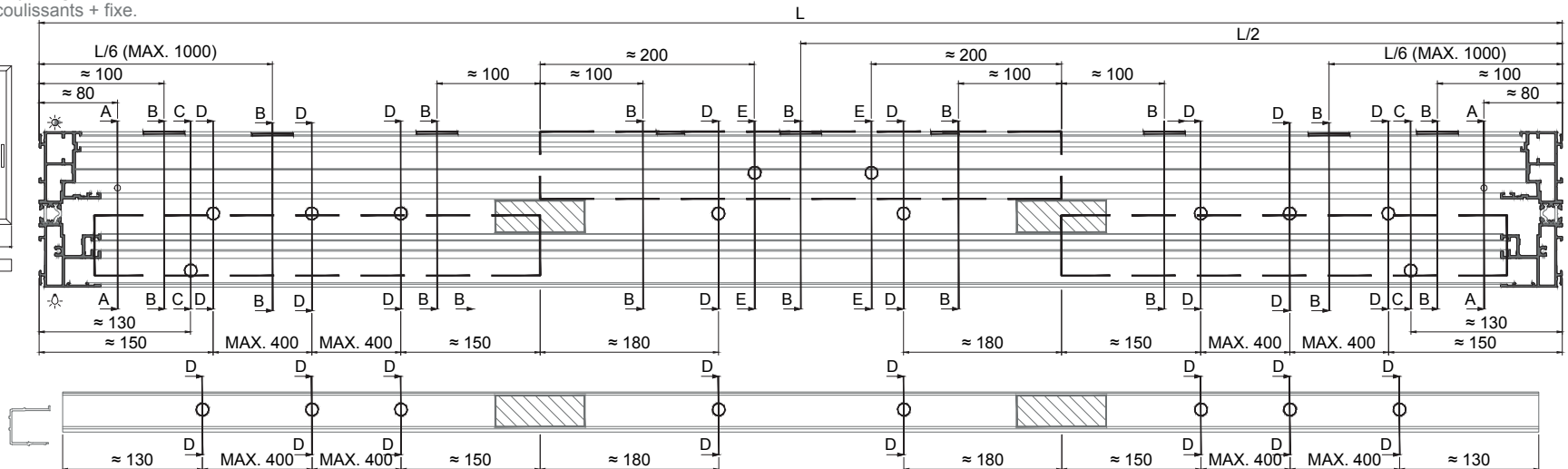
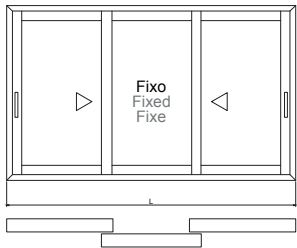

- R1:** Rasgo | Hole | Rainure 6x30mm
- R2:** Rasgo | Hole | Rainure 5x30mm
- R3:** Rasgo | Hole | Rainure 5x20mm
- R5:** Rasgo | Hole | Rainure 5x30mm
- R6:** Furo | Hole | Trou Ø12mm
- R7:** Furo | Hole | Trou Ø8mm

(A) Rasgo realizado com fresa 5mm  
 Hole made by 5mm milling machine  
 Rainure réalisée avec machine de fraiseuse 5mm

**MAQUINAÇÕES DOS PERFIS ARO MÓVEL JT**

JT MOBILE FRAME PROFILES MACHINING

USINAGE DES PROFILÉS OUVRANT JT

**1 - Fresagem dos perfis laterais para colocação dos topos laterais inferiores e superiores.**

Lateral profiles milling for placing the lateral upper and lower end-caps.

Fraisage des profilés latéraux pour placer les embouts latéraux inférieurs et supérieurs.

Maquinação realizada no Cortante  
Machining performed on Punching tool  
Usinage réalisée dans l'Outil

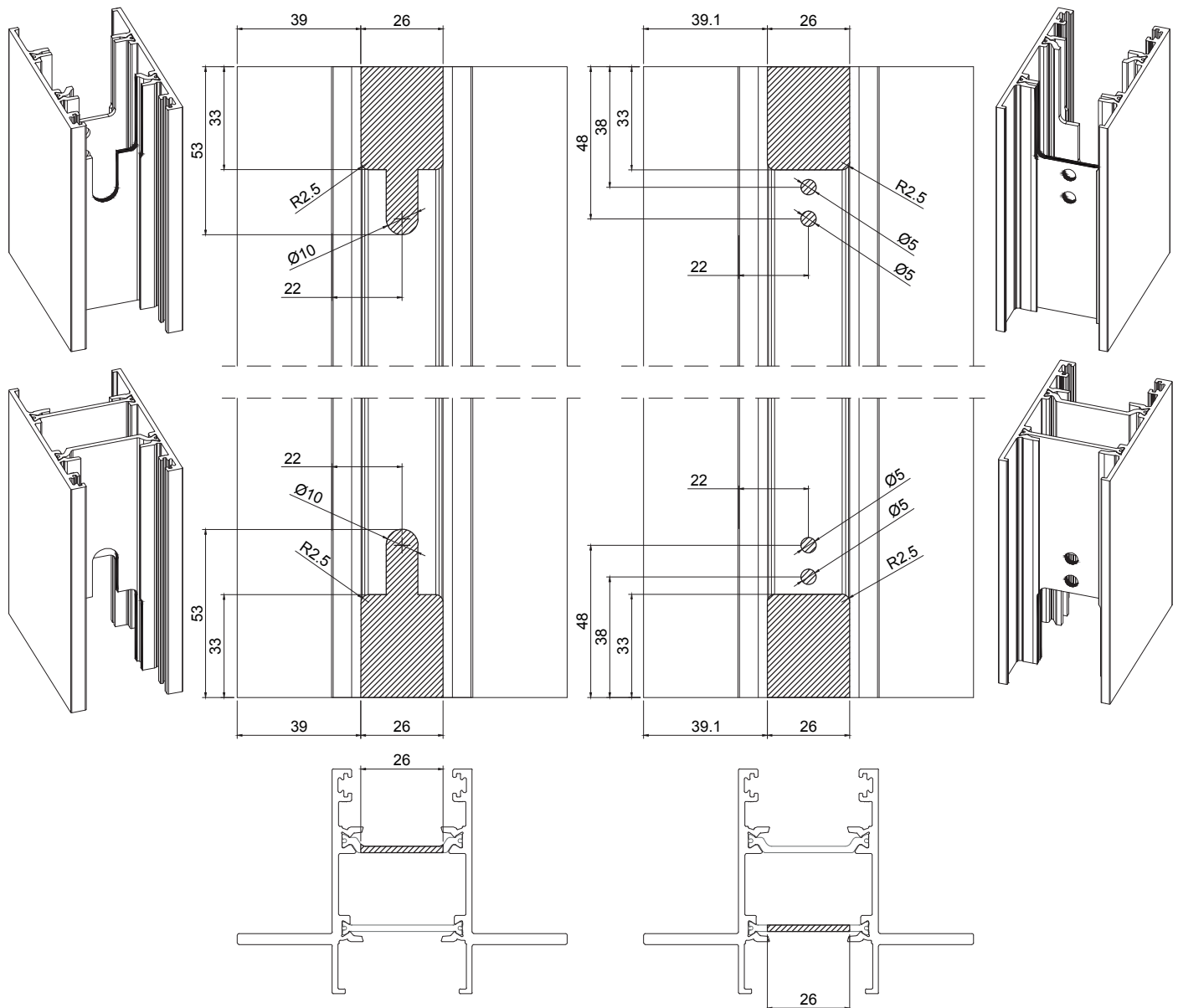

**JT 65**  
**Perfil Lateral**  
Lateral profile | Profilé latéral

**JT 65**  
**Perfil Lateral**  
Lateral profile | Profilé latéral

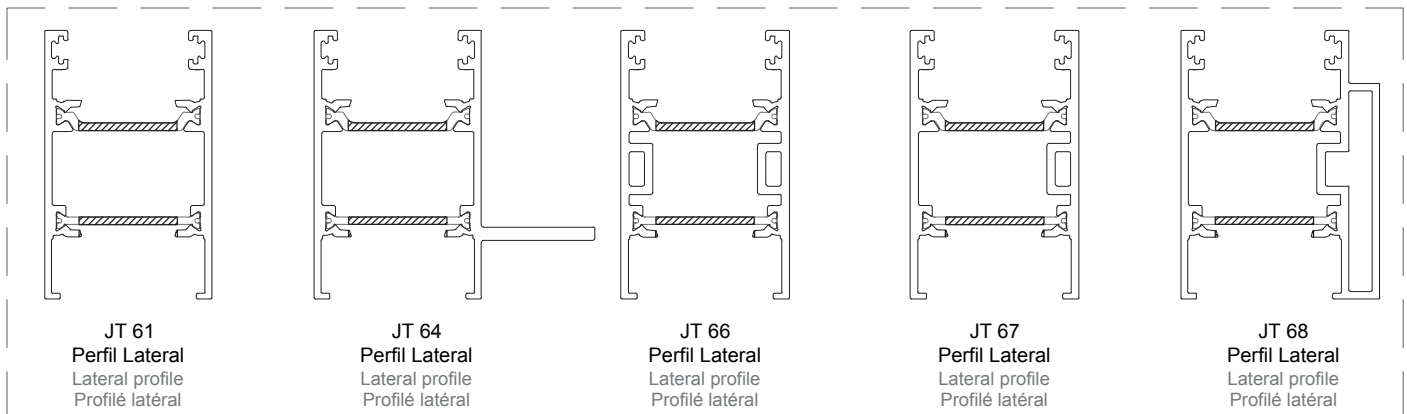

**MAQUINAÇÕES DOS PERFIS ARO MÓVEL JT**

JT MOBILE FRAME PROFILES MACHINING

USINAGE DES PROFILÉS OUVRANT JT

**2 - Fresagem do perfil lateral canto 90° para colocação dos topos laterais inferiores e superiores.**

90° Corner lateral profile milling for placing the lateral upper and lower end-caps.

Fraisage du profilé latéral d'angle 90° pour placer les embouts latéraux inférieurs et supérieurs.

Maquinação realizada no Cortante  
Machining performed on Punching tool  
Usinage réalisée dans l'Outil

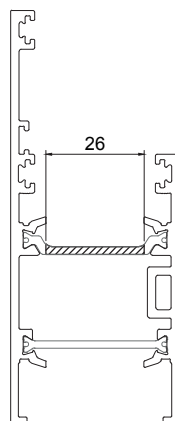
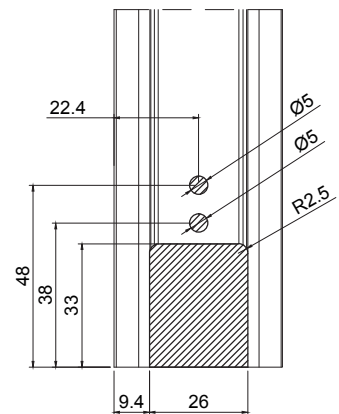
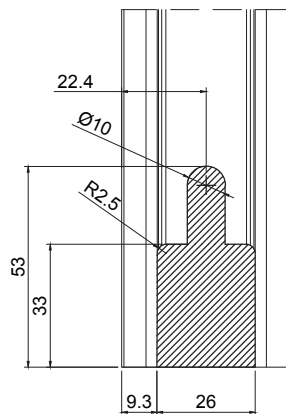
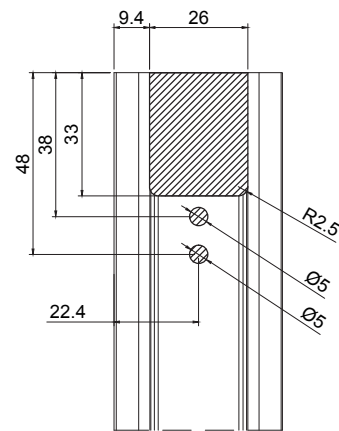
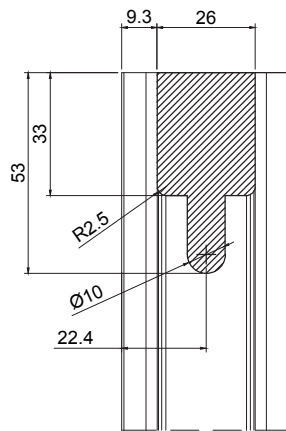

JT 62

Perfil lateral canto 90°

90° Corner lateral profile | Profilé latéral d'angle à 90°

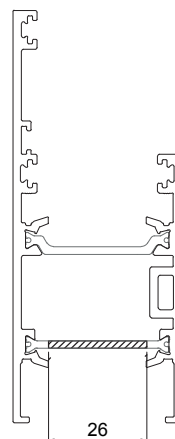

JT 62

Perfil lateral canto 90°

90° Corner lateral profile | Profilé latéral d'angle à 90°

## MAQUINAÇÕES DOS PERFIS ARO MÓVEL JT

JT MOBILE FRAME PROFILES MACHINING

USINAGE DES PROFILÉS OUVRANT JT

### 3 - Fresagem dos perfis laterais para colocação das travessas superior e inferior.

Lateral profiles milling for placing the upper and lower transoms.

Fraisage des profilés latéraux pour la mise en place des traverses supérieures et inférieures.

Maquinação realizada no Cortante

Machining performed on Punching tool  
Usinage réalisée dans l'Outil

**JT 63**  
Travessa superior  
Upper transom | Traverse supérieur

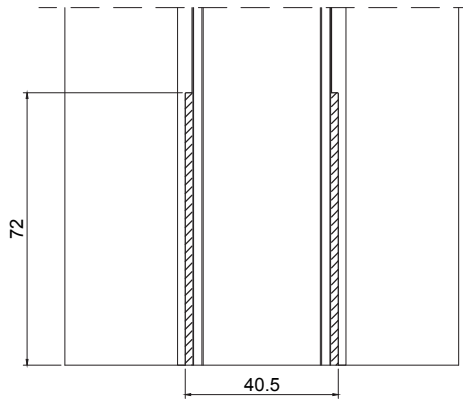
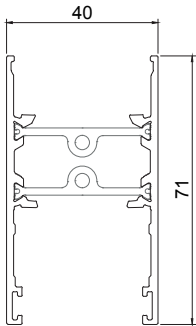
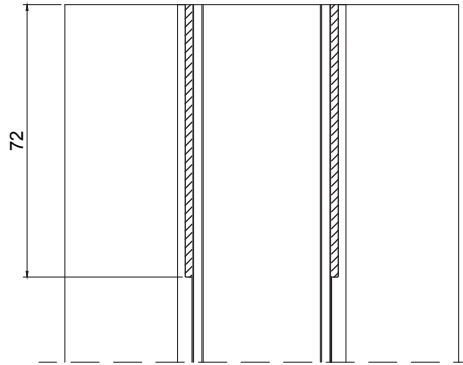
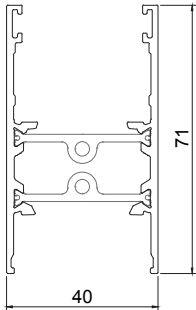

**JT 63**  
Travessa inferior  
Lower transom | Traverse inférieur

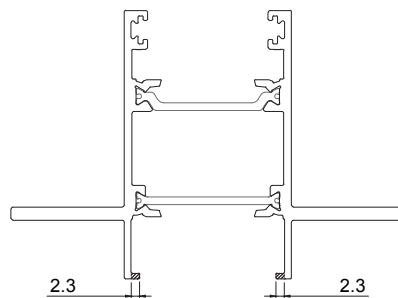

**JT 65**  
Perfil Lateral  
Lateral profile | Profilé latéral

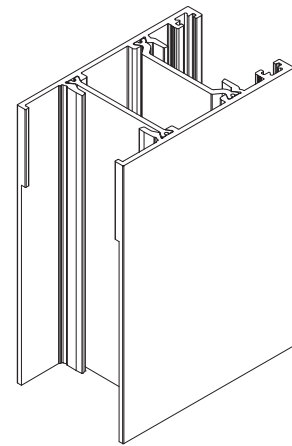
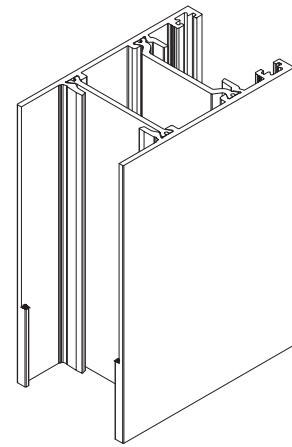

É muito importante que esta  
maquinação seja feita depois da  
maquinação para os topos.  
It is very important that this machining is done  
after the end-caps machining.  
Il est très important que cet usinage se fasse  
après l'usinage des embouts.

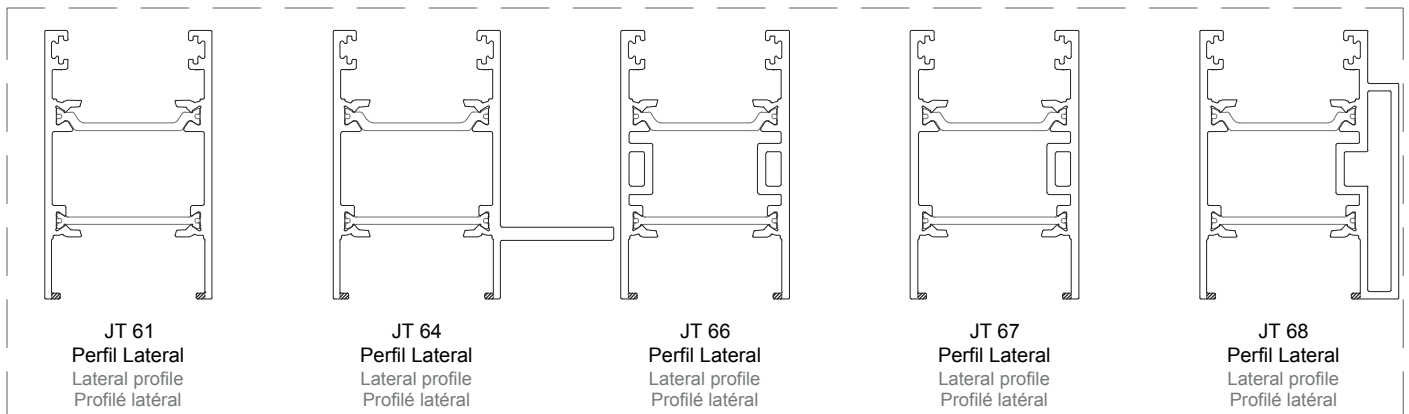

**JT 61**  
Perfil Lateral  
Lateral profile  
Profilé latéral

**JT 64**  
Perfil Lateral  
Lateral profile  
Profilé latéral

**JT 66**  
Perfil Lateral  
Lateral profile  
Profilé latéral

**JT 67**  
Perfil Lateral  
Lateral profile  
Profilé latéral

**JT 68**  
Perfil Lateral  
Lateral profile  
Profilé latéral

## MAQUINAÇÕES DOS PERFIS ARO MÓVEL JT

JT MOBILE FRAME PROFILES MACHINING

USINAGE DES PROFILÉS OUVRANT JT

4 - Fresagem do perfil lateral canto 90° para colocação das travessas superior e inferior.

90° Corner lateral profile milling for placing the upper and lower transoms.

Fraisage du profilé latéral d'angle 90° pour la mise en place des traverses supérieures et inférieures.

Maquinação realizada no Cortante

Machining performed on Punching tool  
Usinage réalisée dans l'Outil

JT 63  
Travessa superior  
Upper transom | Traverse supérieur

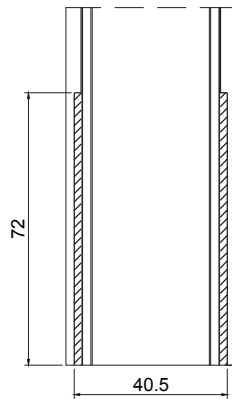
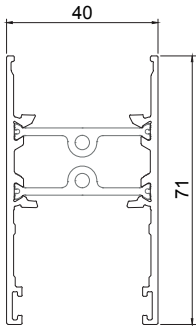
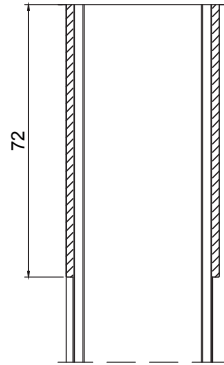
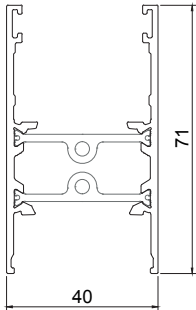

JT 63  
Travessa inferior  
Lower transom | Traverse inférieur

É muito importante que esta  
maquinação seja feita depois da  
maquinação para os topos.

It is very important that this machining is done  
after the end-caps machining.  
Il est très important que cet usinage se fasse  
après l'usinage des embouts.

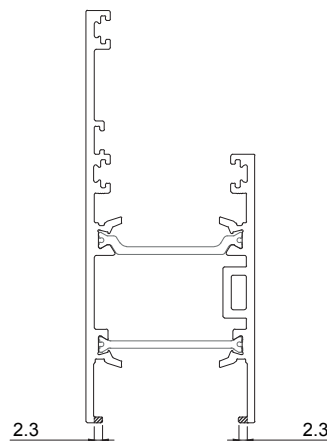

JT 62  
Perfil lateral canto 90°  
90° Corner lateral profile | Profilé latéral d'angle à 90°

**MAQUINAÇÕES DOS PERFIS ARO MÓVEL JT**

JT MOBILE FRAME PROFILES MACHINING

USINAGE DES PROFILÉS OUVRANT JT

**5 - Fresagem dos perfis laterais JT64, JT65 e JT 68.**

JT64, JT 65 and JT 68 lateral profiles milling.

Fraisage des profilés laterales JT64, JT65 et JT68.

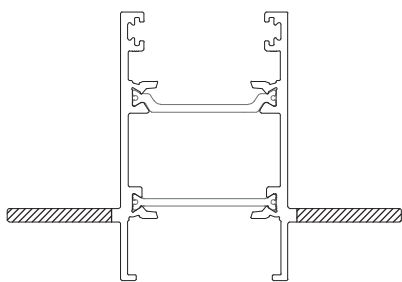
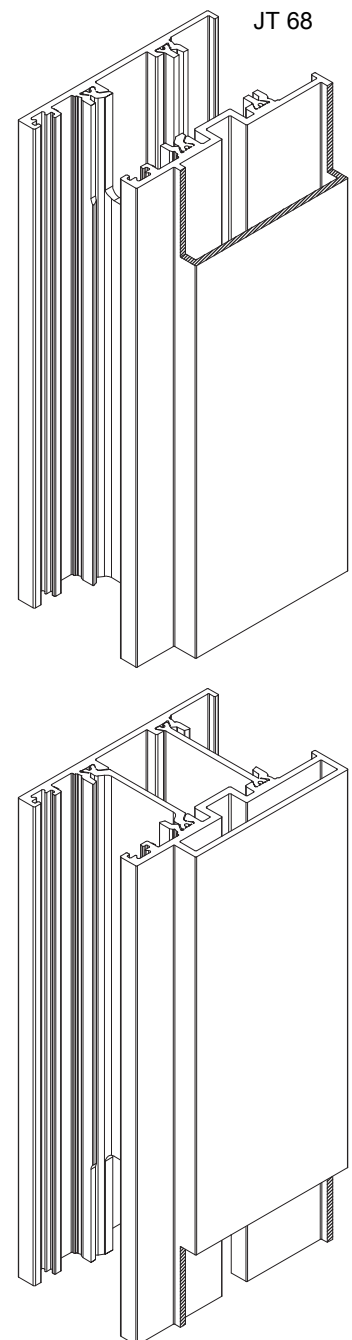
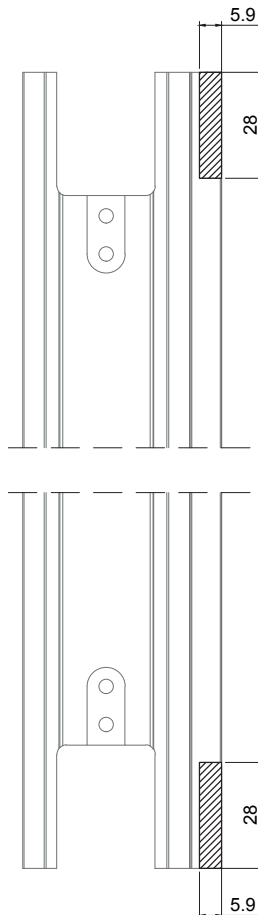
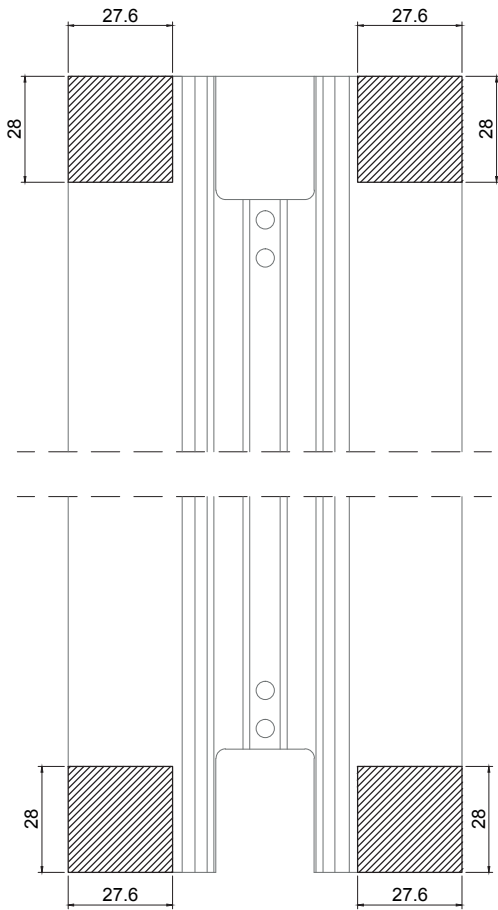

**JT 65**  
**Perfil Lateral**  
Lateral profile | Profilé latéral

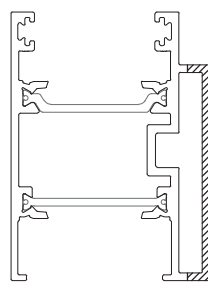

**JT 68**  
**Perfil Lateral**  
Lateral profile | Profilé latéral

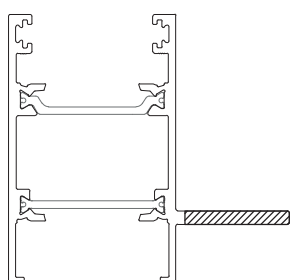

**JT 64**  
**Perfil Lateral**  
Lateral profile | Profilé latéral

**Maquinação não realizada no Cortante**  
Machining **not** performed on Punching tool  
Usinage **non** réalisée dans l'Outil



**MAQUINAÇÕES DOS PERFIS ARO MÓVEL JT**

JT MOBILE FRAME PROFILES MACHINING

USINAGE DES PROFILÉS OUVRANT JT

6 - Fresagem de perfil central e junta central para colocação das travessas superior e inferior.

**Seguir este procedimento em todos os perfis centrais.**

Central profile and joint milling for placing the upper and lower transoms.

**Follow this procedure in all central profiles.**

Fraisage du profilé central et du joint central pour la mise en place des traverses supérieure et inférieure.

**Suivre cette procédure sur tous les profilés centraux.**

Maquinação realizada no Cortante  
Machining performed on Punching tool  
Usinage réalisée dans l'Outil

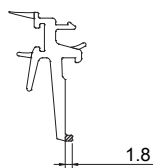
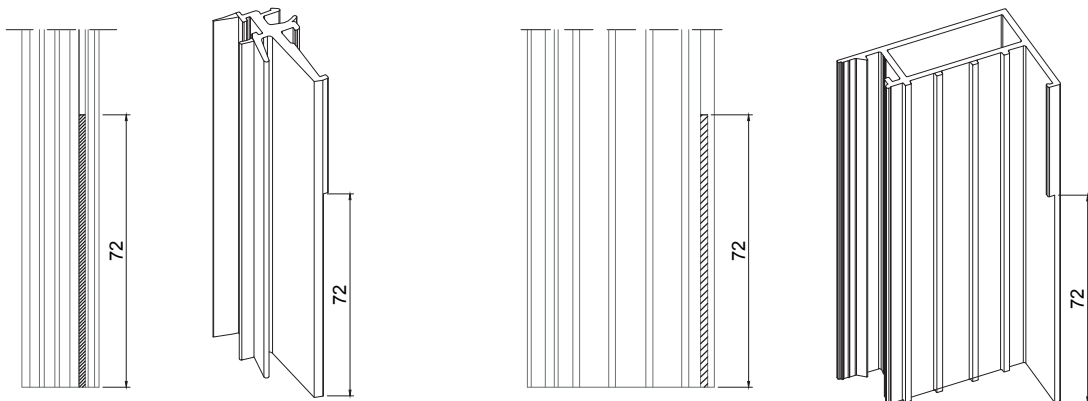
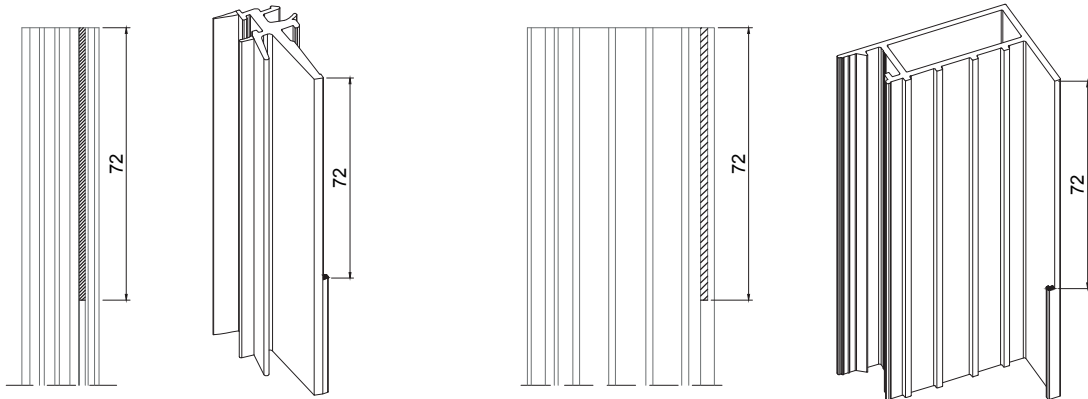

JUNTA CENTRAL 2196 JT  
JT 2196 CENTRAL JOINT  
JOINT CENTRALE 2196 JT

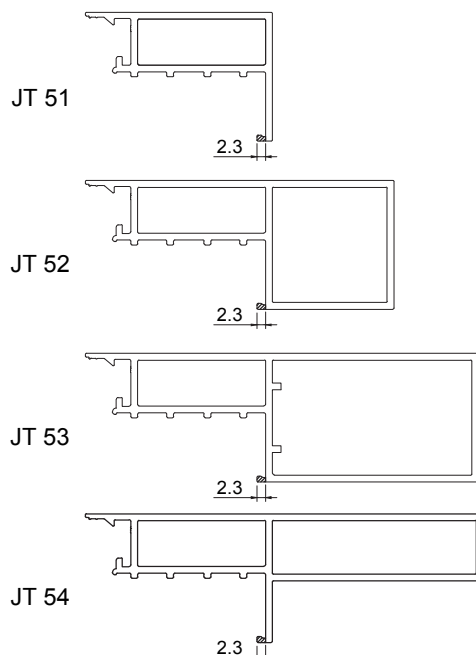

## MAQUINAÇÕES DOS PERFIS ARO MÓVEL JT

JT MOBILE FRAME PROFILES MACHINING

USINAGE DES PROFILÉS OUVRANT JT

7 - Fresagem do perfil central para colocação dos topos centrais superiores e inferiores.

**Seguir este procedimento em todos os perfis centrais.**

Central profile milling for placing the central upper and lower end-caps.

**Follow this procedure in all central profiles.**

Fraisage du profilé central pour la mise en place des plateaux centraux supérieur et inférieur.

Suivre cette procédure sur tous les profilés centraux.

Maquinação realizada no Cortante

Machining performed on Punching tool  
Usinage réalisée dans l'Outil

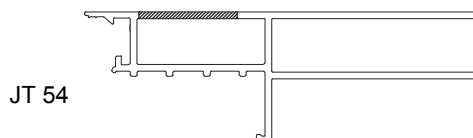
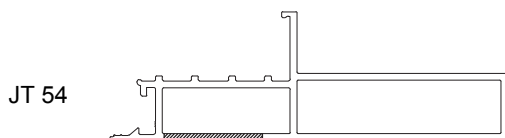
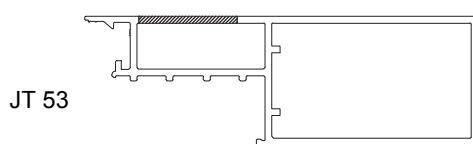
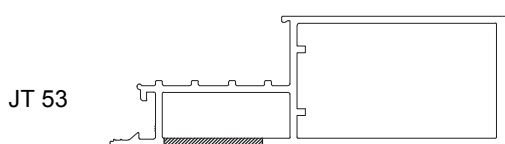
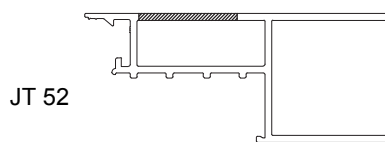
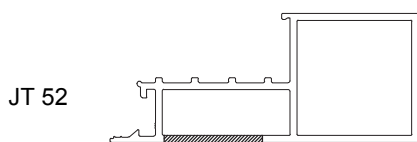
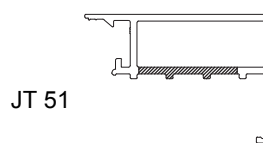
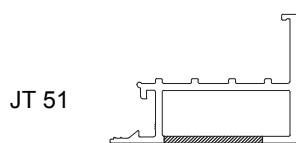
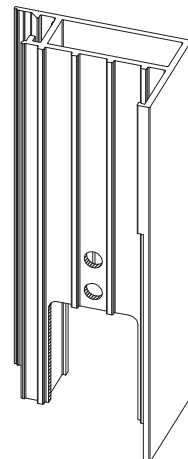
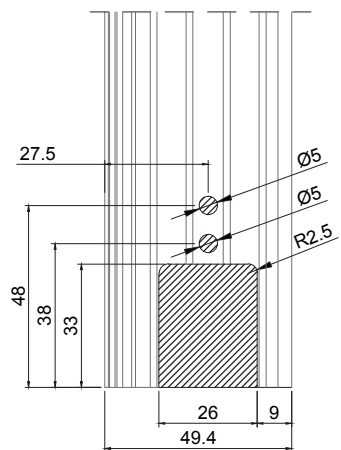
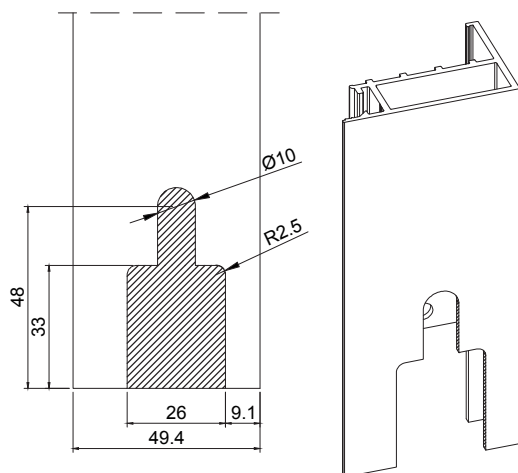
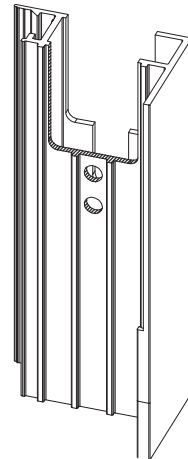
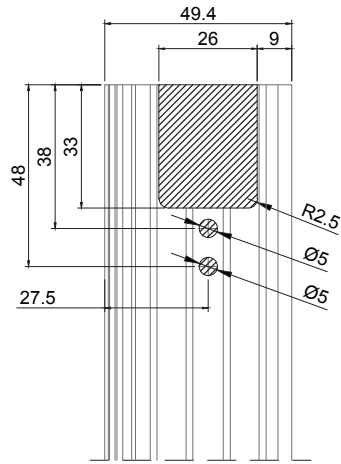
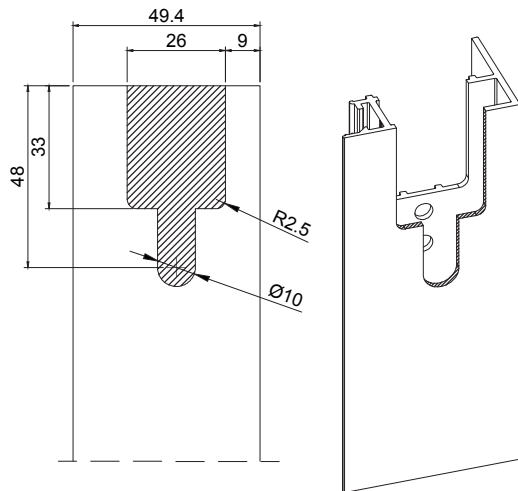

**MAQUINAÇÕES DOS PERFIS ARO MÓVEL JT**  
JT MOBILE FRAME PROFILES MACHINING  
USINAGE DES PROFILÉS OUVRANT JT

8 - Fresagem dos perfis centrais de reforço.

**Seguir este procedimento em todos os perfis centrais.**

Reinforcement central profile milling.

**Follow this procedure in all central profiles.**

Fraisage des profilés de renfort centraux.

**Suivre cette procédure sur tous les profilés centraux.**

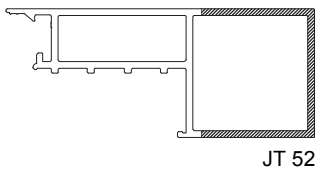
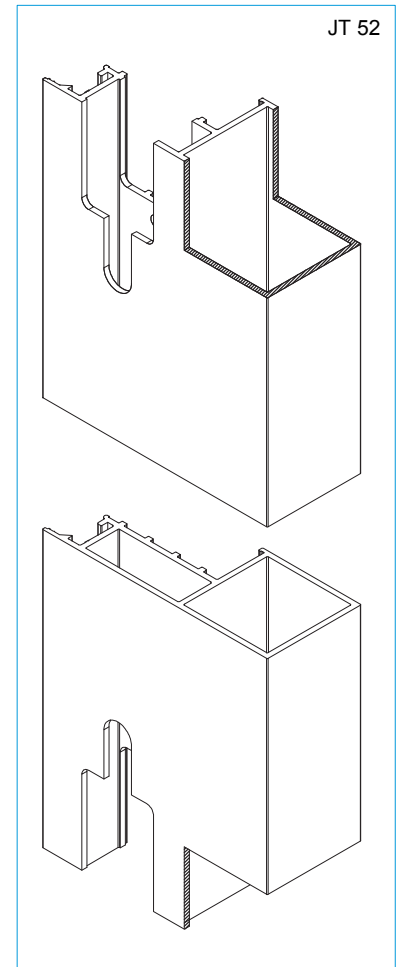
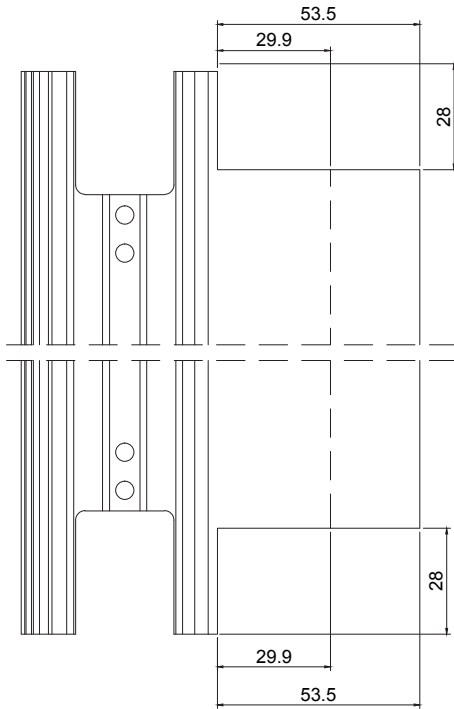

JT 52

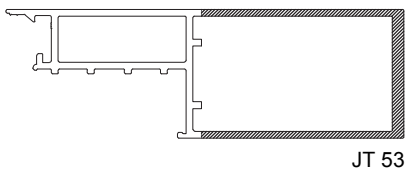

JT 53

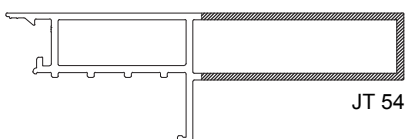

JT 54

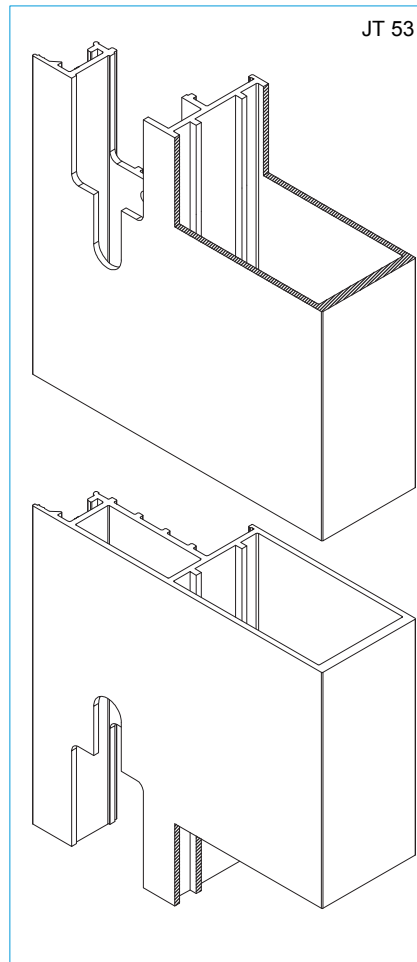

JT 53

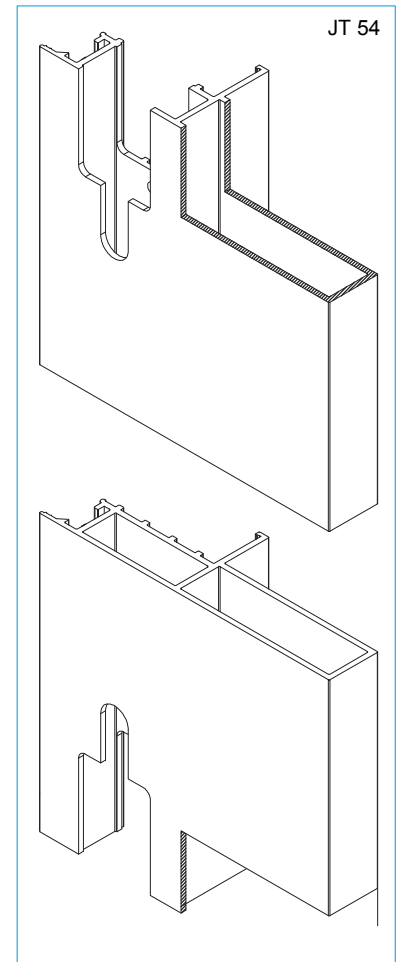

JT 54

**MAQUINAÇÕES DOS PERFIS ARO MÓVEL JT**  
JT MOBILE FRAME PROFILES MACHINING  
USINAGE DES PROFILÉS OUVRANT JT

**9 - Aplicação do limitador de abertura na travessa inferior JT 63.**  
Opening limiter application on the lower transom JT 63.  
Application du limiteur d'ouverture sur la traverse inférieure JT 63.

**9.1 - Furação para a fixação do limitador de abertura.**  
Drilling for fixing the opening limiter.  
Perçage pour fixation du limiteur d'ouverture.

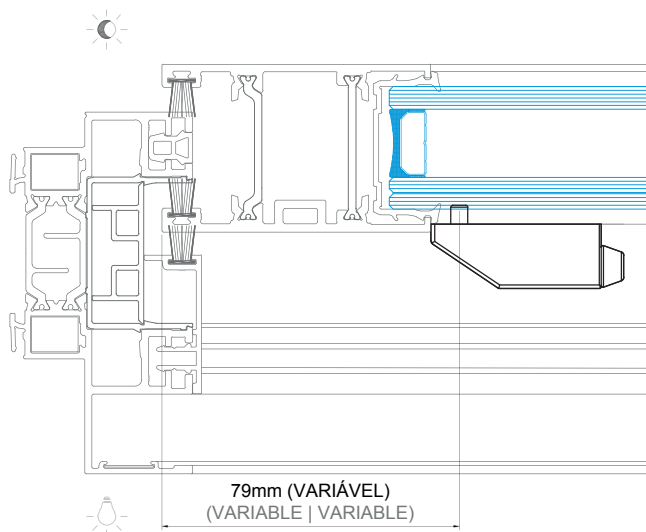
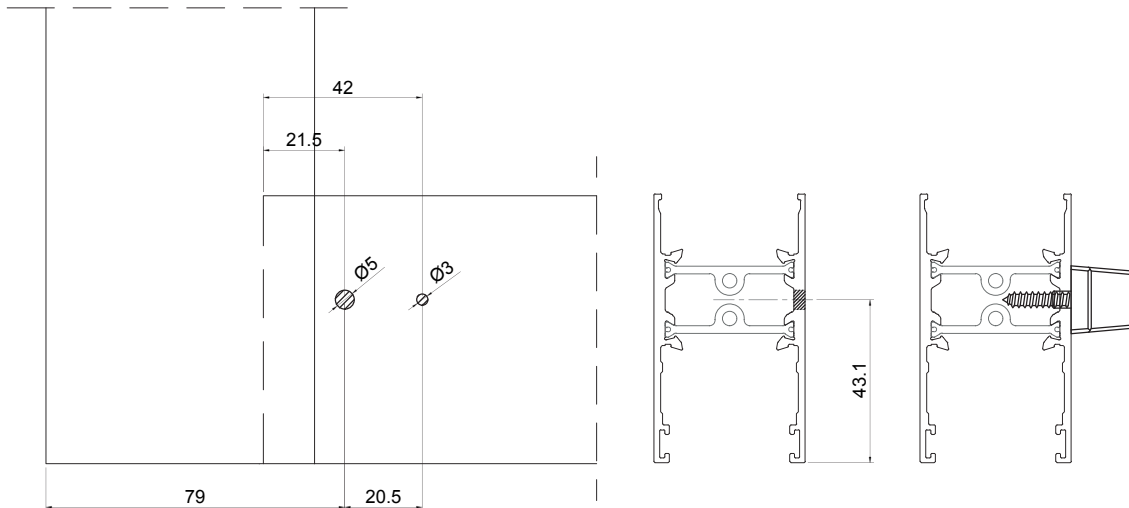
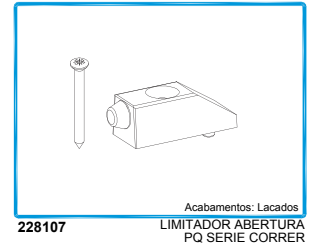

**Medida variável mediante cremone a aplicar.**  
Variable measure by means of handle to be applied.  
Mesure variable utilisant la cremone à appliquer.

**6.2 - Aparafusar o limitador de abertura à travessa.**  
Screw the opening limiter to the transom.  
Visser le limiteur d'ouverture sur la traverse.

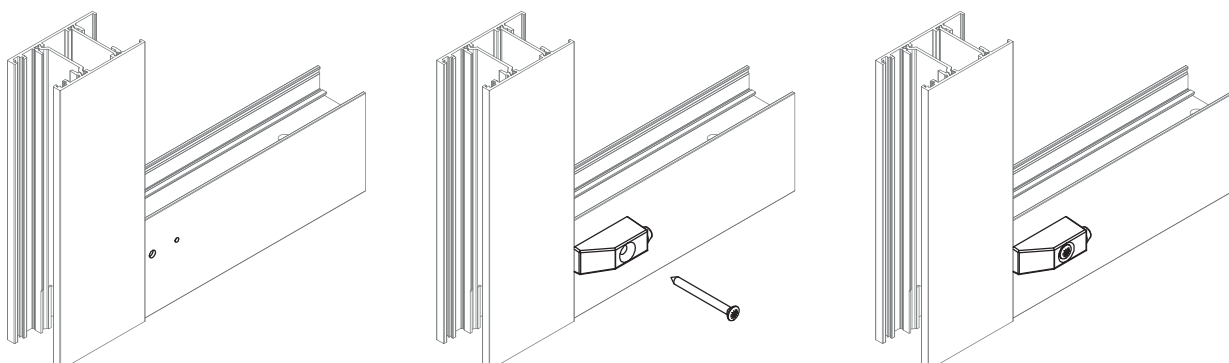

**MAQUINAÇÕES DOS PERFIS ARO MÓVEL JT**  
JT MOBILE FRAME PROFILES MACHINING  
USINAGE DES PROFILÉS OUVRANT JT

**10 - Furação para drenagens e descompressão e aplicação dos carrinhos.**  
Drainage and decompression drilling and rollers application.  
Perçage pour drainage et décompression et application des roulettes.

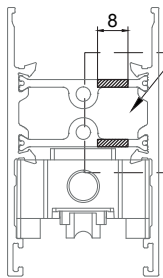

Os furos devem ser feitos no lado exterior do perfil  
The holes must be drilled on the outside of the profile  
Les trous doivent être percés à l'extérieur du profilé

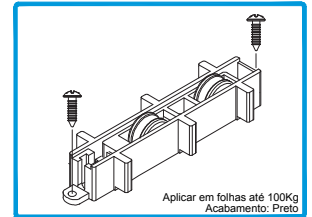

**205108** CARRINHO JT 100KG

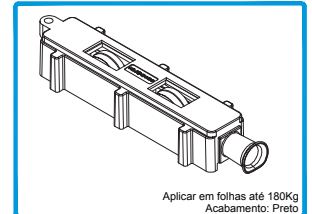

**205129** CARRINHO JT 180KG

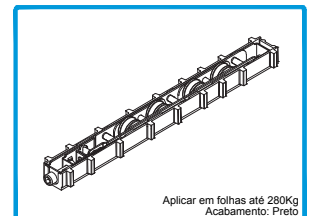

**205201** CARRINHO JT HEAVY DUTY

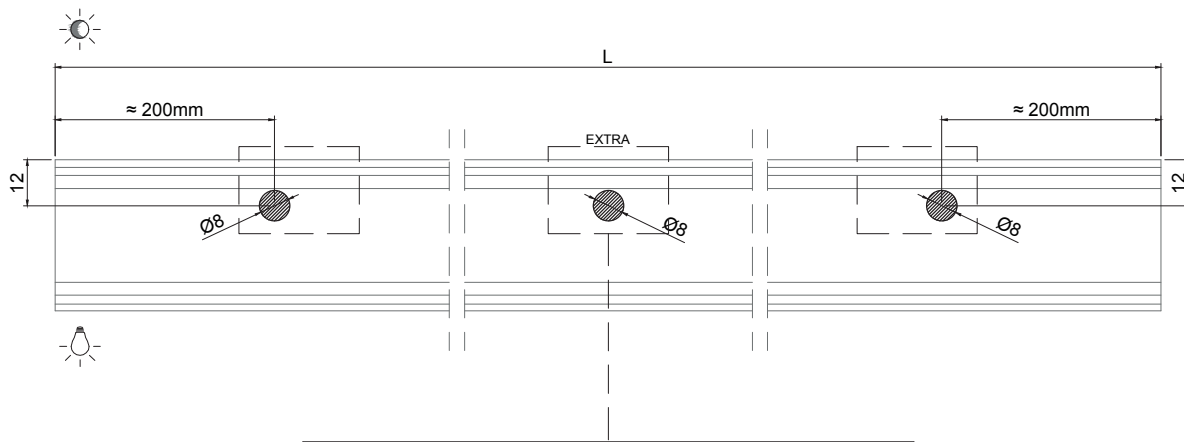

Se  $L \geq 1m$ , fazer um furo adicional ao centro da travessa inferior  
If  $L \geq 1m$ , drill an additional hole in the center of the lower transom  
Si  $L \geq 1m$ , percer un trou supplémentaire au centre de la traverse inférieure

## MAQUINAÇÕES DOS PERFIS ARO MÓVEL JT

JT MOBILE FRAME PROFILES MACHINING

USINAGE DES PROFILÉS OUVRANT JT

### 11 - Ferragens 1 Ponto e Multiponto.

1 Point and Multipoint Hardwares.

Serrures 1 Point and Multipoint.

#### 11.1 - Altura do furo do cremone no perfil lateral, com aro fixo FR.

Handle's hole height in the side profile, with FR fixed frame.

Hauteur du trou de crémonne dans le profilé latéral, avec dormant FR.

**Hcrem, pl = Hcrem, solo - 40mm**  
**Hhandle, lp = Hhandle, ground - 40mm**  
**Hcrem, pl = Hcrem, sol - 40mm**

#### Exemplo | Example | Exemple:

Para colocação do mecanismo de fecho a 1000mm relativamente ao solo, o centro da maquinação deverá ser feito no perfil lateral a uma altura de 1000-40=960mm.

For placing the closing mechanism at 1000mm in relation to the ground, the machining center should be made in the lateral profile at a height of 1000-40=960mm.

Pour placer le mécanisme de fermeture à 1000mm par rapport au sol, le centre d'usinage doit être réalisé dans le profilé latéral à une hauteur de 1000-40=960mm.

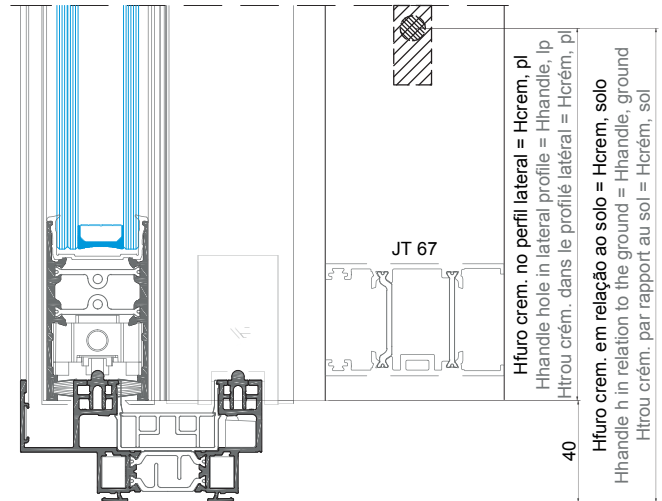

#### 11.2 - Altura do furo do cremone no perfil lateral, com aro fixo PT.

Handle's hole height in the side profile, with PT fixed frame.

Hauteur du trou de crémonne dans le profilé latéral, avec dormant PT.

**Hcrem, pl = Hcrem, solo - 37mm**  
**Hhandle, lp = Hhandle, ground - 37mm**  
**Hcrem, pl = Hcrem, sol - 37mm**

#### Exemplo | Example | Exemple:

Para colocação do mecanismo de fecho a 1000mm relativamente ao solo, o centro da maquinação deverá ser feito no perfil lateral a uma altura de 1000-37=963mm.

For placing the closing mechanism at 1000mm in relation to the ground, the machining center should be made in the lateral profile at a height of 1000-37=963mm.

Pour placer le mécanisme de fermeture à 1000mm par rapport au sol, le centre d'usinage doit être réalisé dans le profilé latéral à une hauteur de 1000-37=963mm.

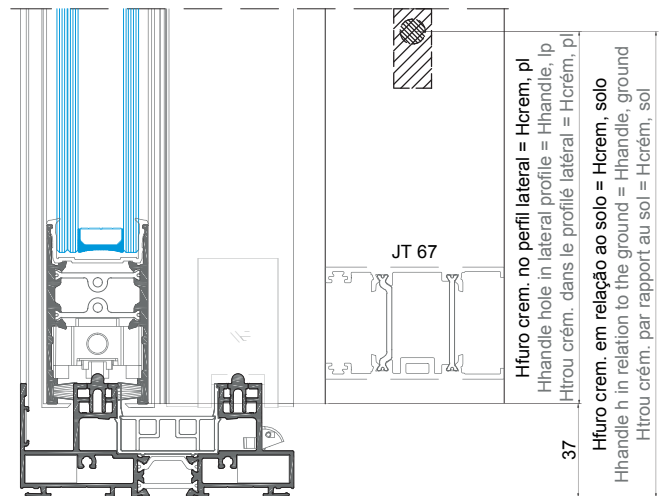

#### 11.3 - Altura do furo do cremone no perfil lateral, com soleira 30mm.

Handle's hole height in the side profile, with 30mm sill.

Hauteur du trou de crémonne dans le profilé latéral, avec seuil 30mm.

**Hcrem, pl = Hcrem, solo - 22mm**  
**Hhandle, lp = Hhandle, ground - 22mm**  
**Hcrem, pl = Hcrem, sol - 22mm**

#### Exemplo | Example | Exemple:

Para colocação do mecanismo de fecho a 1000mm relativamente ao solo, o centro da maquinação deverá ser feito no perfil lateral a uma altura de 1000-22=978mm.

For placing the closing mechanism at 1000mm in relation to the ground, the machining center should be made in the lateral profile at a height of 1000-22=978mm.

Pour placer le mécanisme de fermeture à 1000mm par rapport au sol, le centre d'usinage doit être réalisé dans le profilé latéral à une hauteur de 1000-22=978mm.

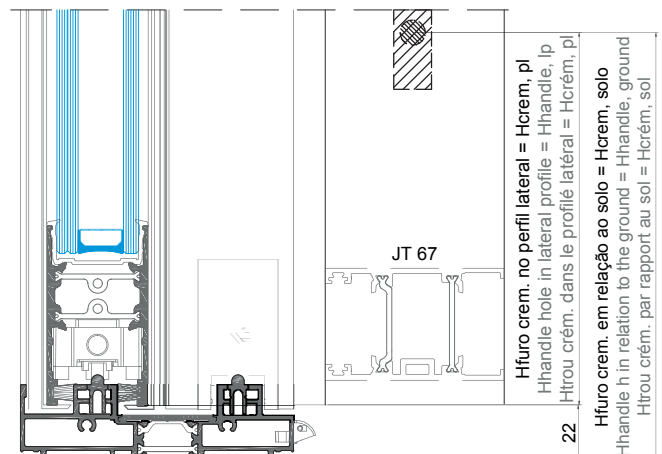



**MAQUINAÇÕES DOS PERFIS ARO MÓVEL JT**

JT MOBILE FRAME PROFILES MACHINING

USINAGE DES PROFILÉS OUVRANT JT

**12 - Ferragem 1 ponto ALU.**

ALU 1 point Hardware.  
Serrure 1 point ALU.

**12.1 - Maquinações e esquema de aplicação.**

Milling and application scheme.  
Usinage et schéma d'application.

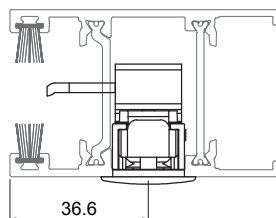
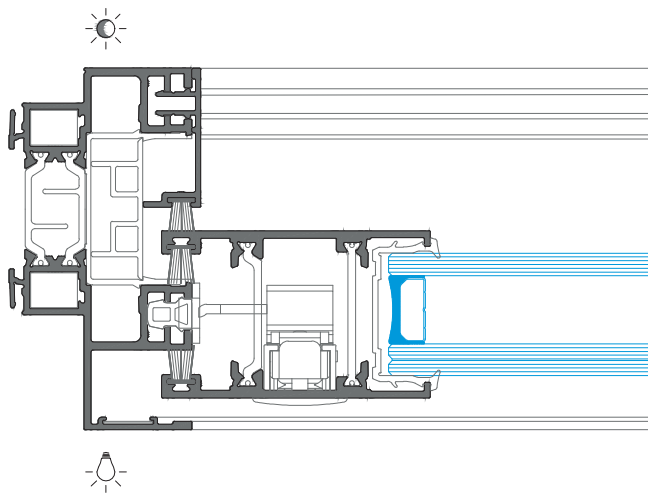
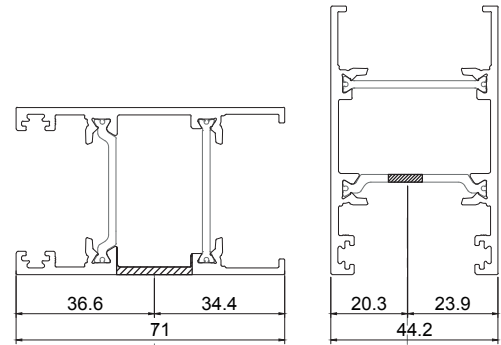
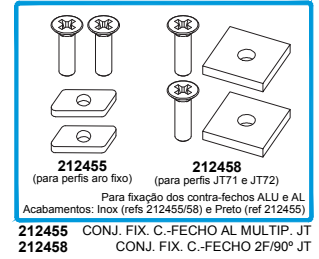
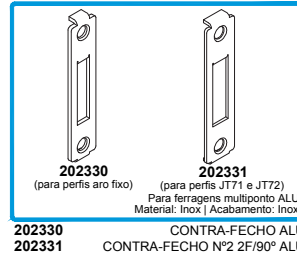
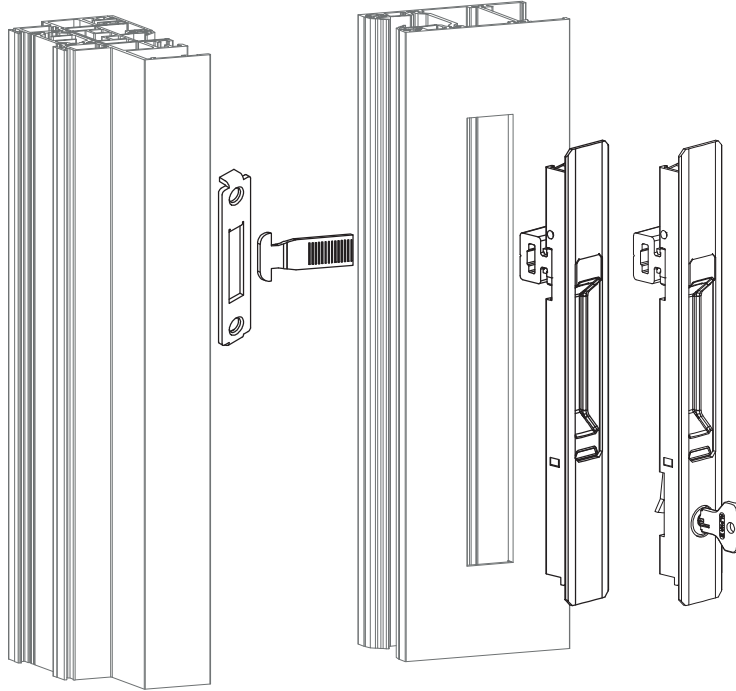
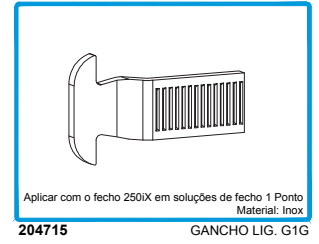
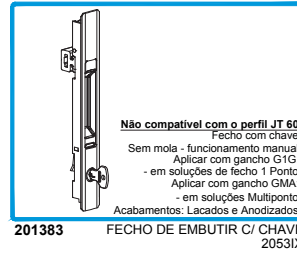
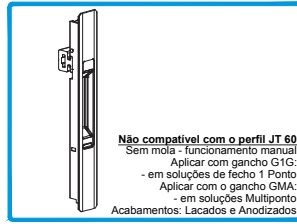

**JT 61**  
Perfil Lateral  
Lateral profile | Profilé latéral

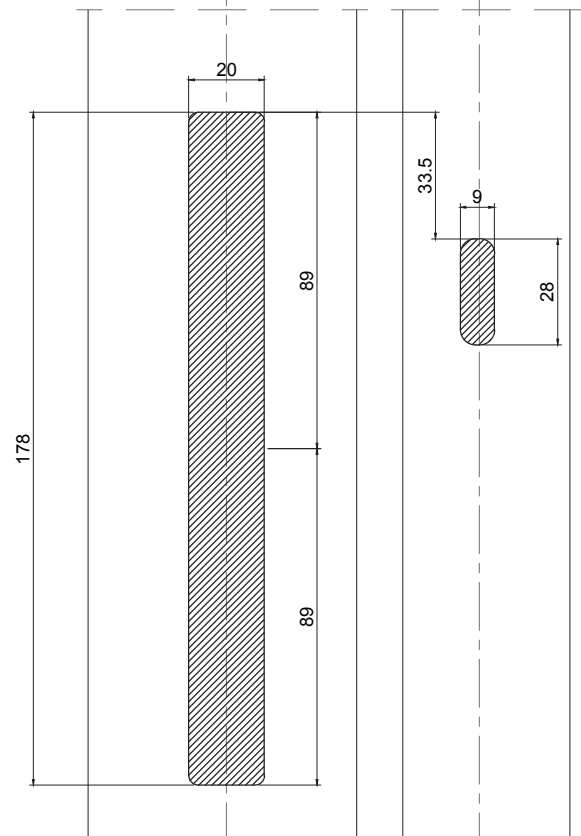

**MAQUINAÇÕES DOS PERFIS ARO MÓVEL JT**  
JT MOBILE FRAME PROFILES MACHINING  
USINAGE DES PROFILÉS OUVRANT JT

**13 - Ferragem Multiponto MAE ALU.**  
ALU MAE Multipoint Hardware.  
Serrure Multipoint MAE ALU.

**13.1 - Esquema de aplicação.**  
Application scheme.  
Schéma d'application.

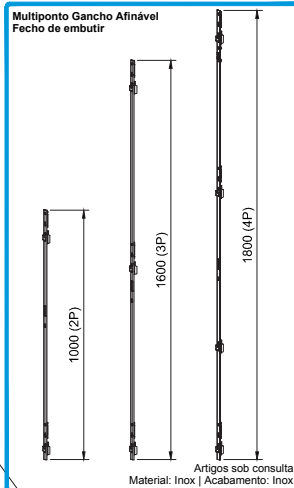
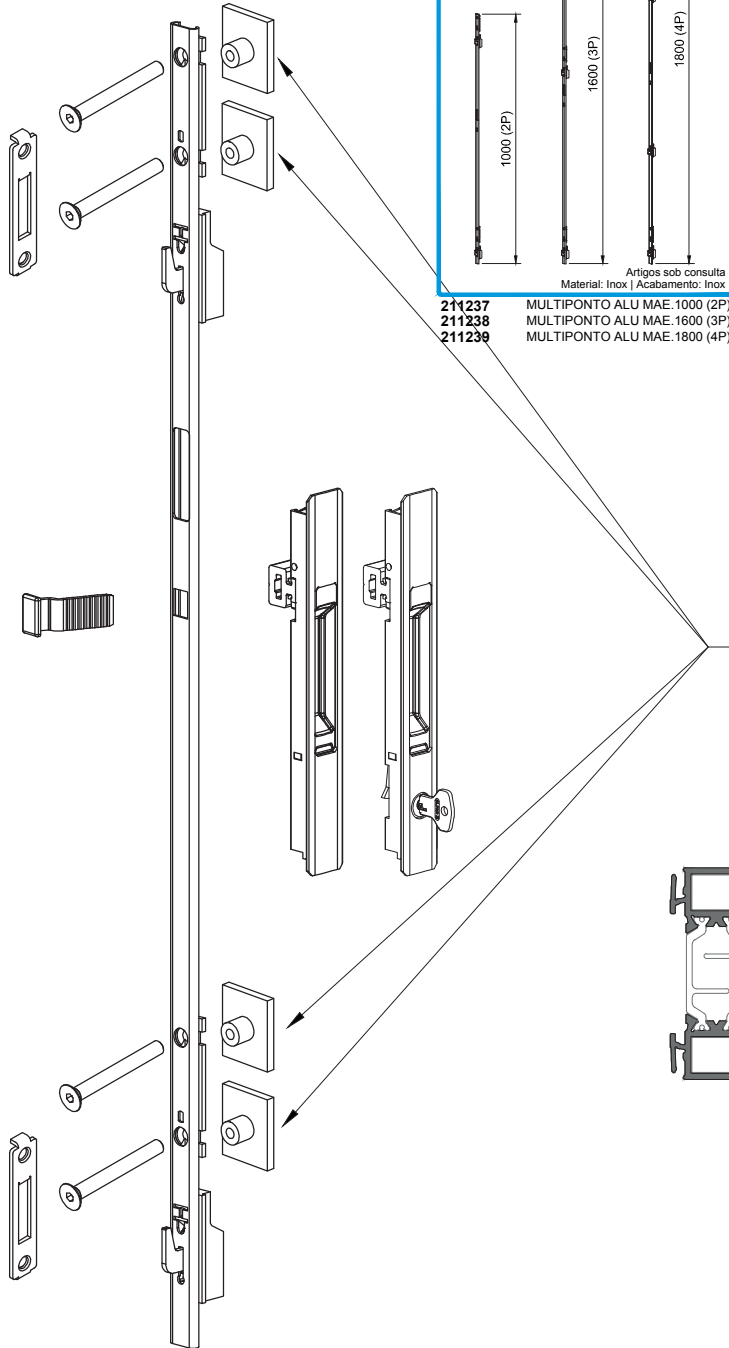

- 211237 MULTIPONTO ALU MAE.1000 (2P)
- 211238 MULTIPONTO ALU MAE.1600 (3P)
- 211239 MULTIPONTO ALU MAE.1800 (4P)

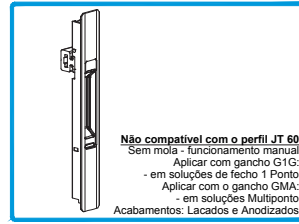

**201382 FECHO DE EMBUTIR R2051X**

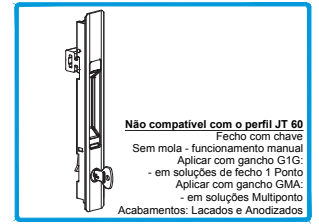

**201383 FECHO DE EMBUTIR C/ CHAVE 2053X**

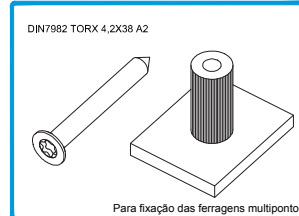

**212371 CONJ. FIXAÇÃO JT**

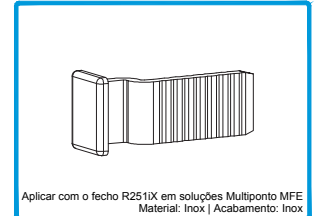

**204717 GANCHO LIG. MULTIPONTO GMA**

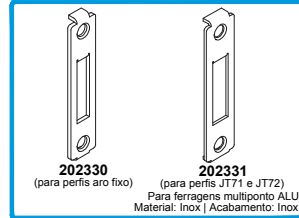

**202330 202331 CONTRA-FECHO ALU CONTRA-FECHO Nº2 2F/90° ALU**

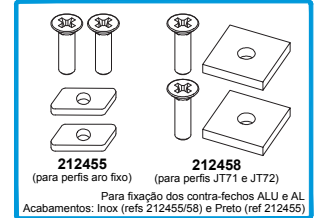

**212455 212458 CONJ. FIX. C.-FECHO AL MULTIP. JT CONJ. FIX. C.-FECHO 2F/90° JT**

Estas peças devem ser coladas ao perfil móvel.  
These parts must be glued to the mobile profile.  
Ces pièces doivent être collées au profilé mobile.

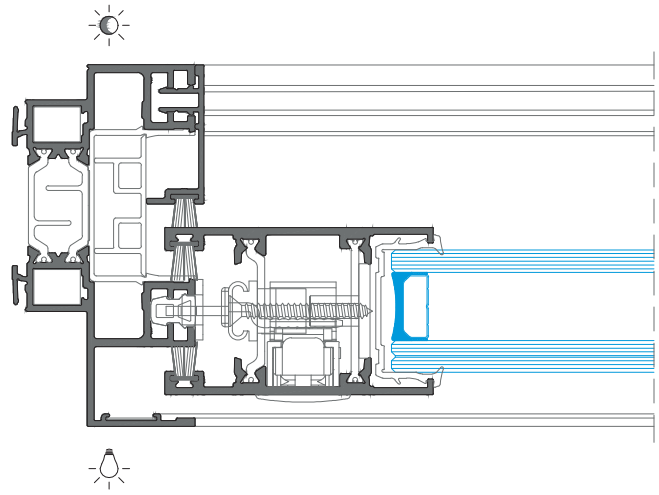

**Perfis Laterais | Lateral profiles | Profilés latéraux:**

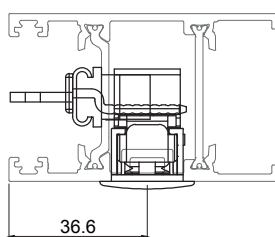

**JT 61**

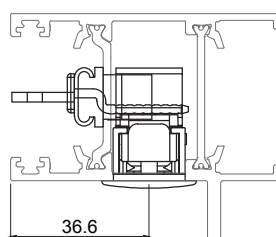

**JT 64**

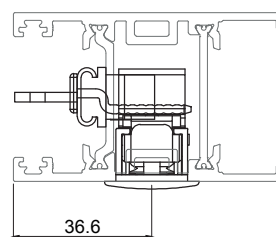

**JT 66**

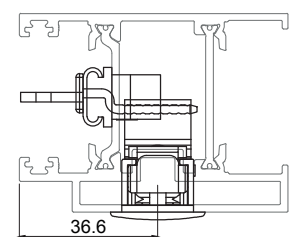

**JT 68**

**MAQUINAÇÕES DOS PERFIS ARO MÓVEL JT**  
JT MOBILE FRAME PROFILES MACHINING  
USINAGE DES PROFILÉS OUVRANT JT

**13 - Ferragem Multiponto MAE ALU.**  
ALU MAE Multipoint Hardware.  
Serrure Multipoint MAE ALU.

**13.2 - Medidas e maquinações.**  
Measures and milling.  
Mesures et usinages.

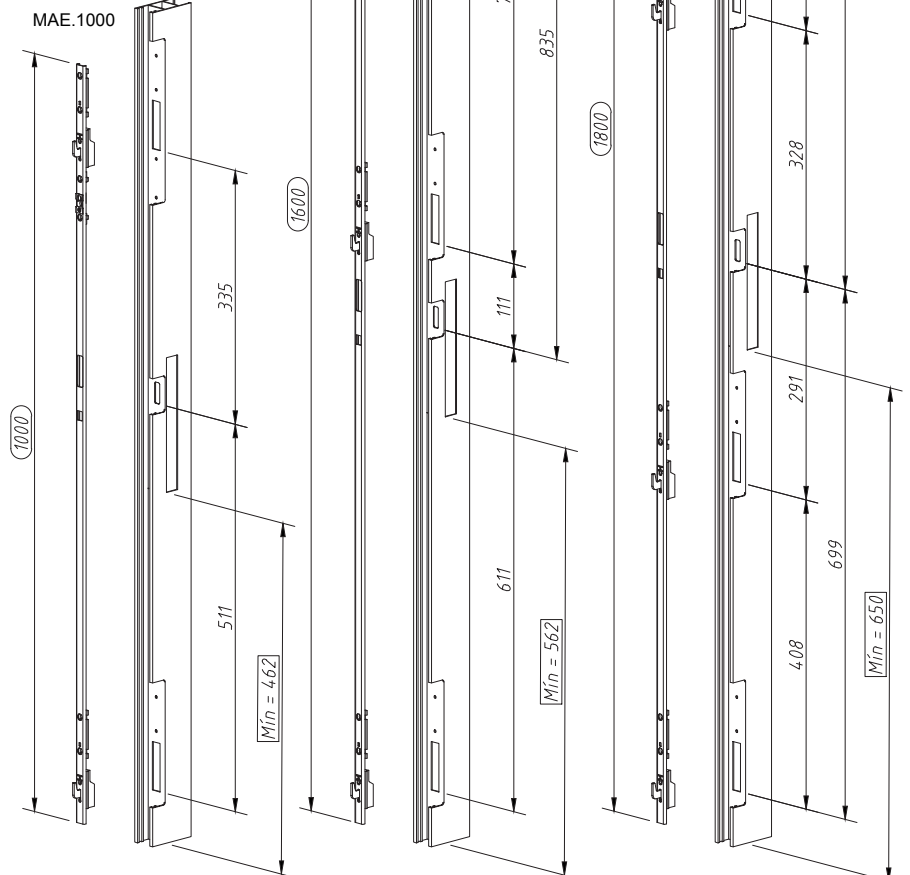
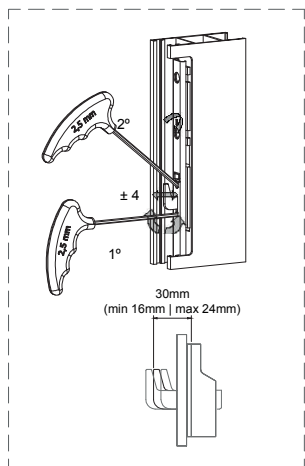
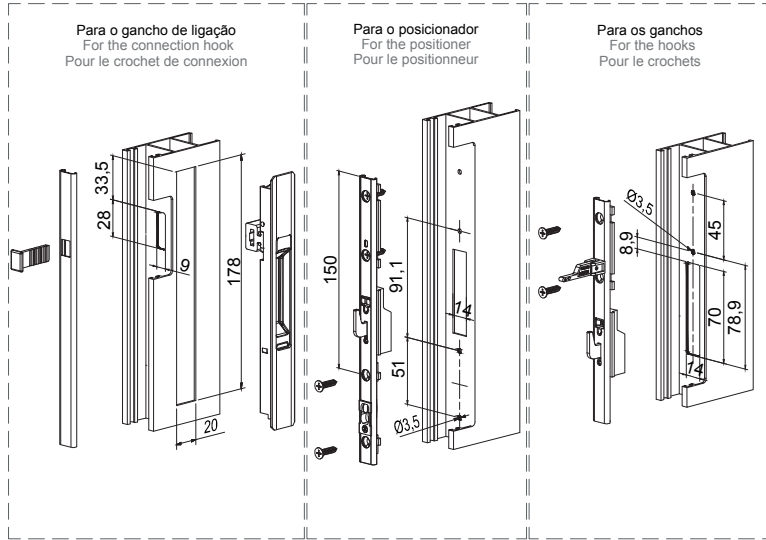

ACESSÓRIOS A CONSIDERAR POR FERRAGEM: ACCESSORIES TO CONSIDER BY HARDWARE: ACCESSOIRES À CONSIDÉRER PAR LE SERRURE:			
Ref.	MAE.1000 (2P)	MAE.1600 (3P)	MAC.1800 (4P)
201381   201382	1	1	1
212371	6	8	10
202330 (a) ou   ou   or 202331 (b)	2	3	4
212455 (a) ou   ou   or 212458 (b)	2	3	4

(a) Para tipologias de aro fixo.  
For fixed frame typologies. | Pour les types de châssis fixes.  
(b) Para tipologias de encontro no mesmo rail e canto.  
For meeting on the same rail and corner typologies. | Pour les typologies de réunion sur le même rail et d'angle.

**MAQUINAÇÕES DOS PERFIS ARO MÓVEL JT**  
JT MOBILE FRAME PROFILES MACHINING  
USINAGE DES PROFILÉS OUVRANT JT

**14 - Ferragem Multiponto MAC ALU.**  
ALU MAC Multipoint Hardware.  
Serrure Multipoint MAC ALU.

**14.1 - Esquema de aplicação.**  
Application scheme.  
Schéma d'application.

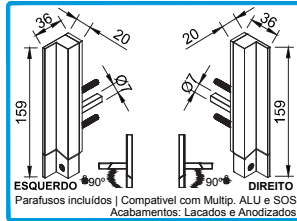
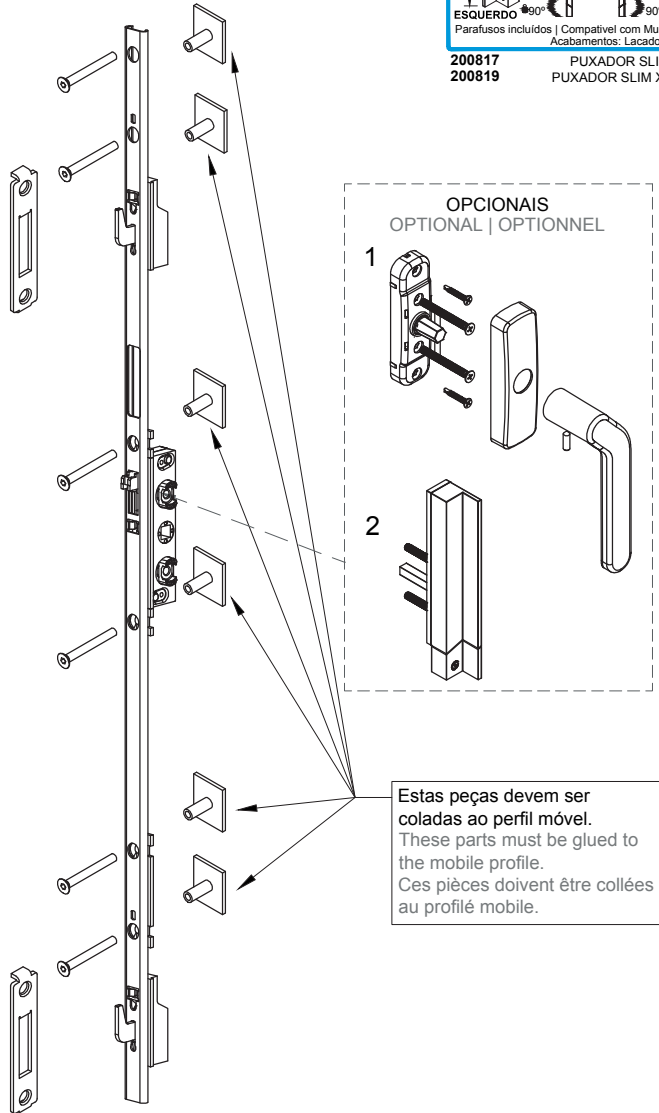

**200817** PUXADOR SLIM XS (Direito)  
**200819** PUXADOR SLIM XS (Esquerdo)

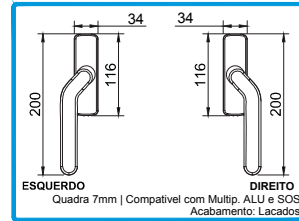

**200959** CREMONE MULT. DESVIADO DIR  
**200939** CREMONE MULT. DESVIADO ESQ

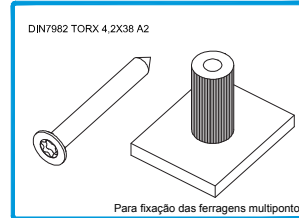

**212371** CONJ. FIXAÇÃO JT

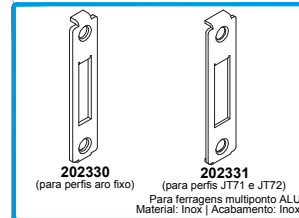

**202330** CONTRA-FECHO ALU  
**202331** CONTRA-FECHO Nº2 2F/90° ALU

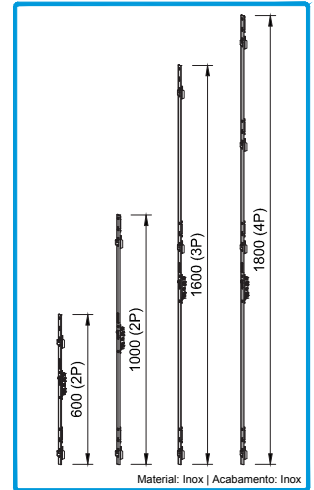

**211233** MULTIPONTO ALU MAC.600 (2P)  
**211234** MULTIPONTO ALU MAC.1000 (2P)  
**211235** MULTIPONTO ALU MAC.1600 (3P)  
**211236** MULTIPONTO ALU MAC.1800 (4P)

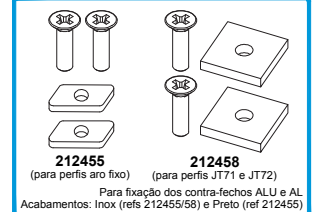

**212455** CONJ. FIX. C.-FECHO AL MULTIP. JT  
**212458** CONJ. FIX. C.-FECHO 2F/90° JT

**CREMONE MULTIPONTO DESVIADO**  
DEVIATED MULTIPPOINT HANDLE | CRÉMONE MULTIPOINT DÉVIÉ

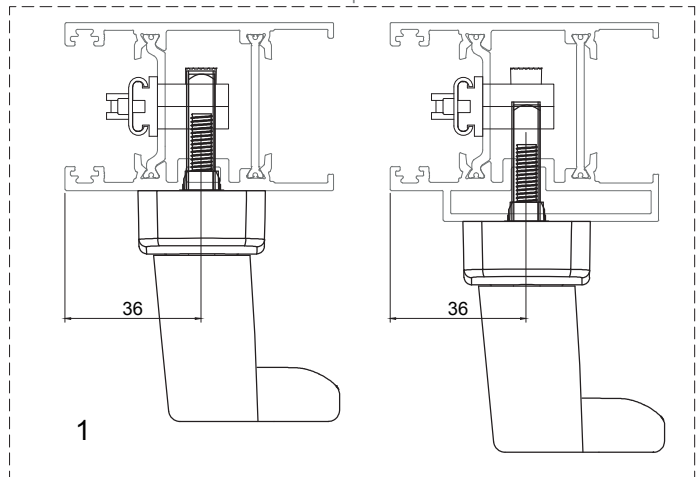

**PUXADOR SLIM XS**  
XS SLIM HANDLE | POIGNÉE SLIM XS

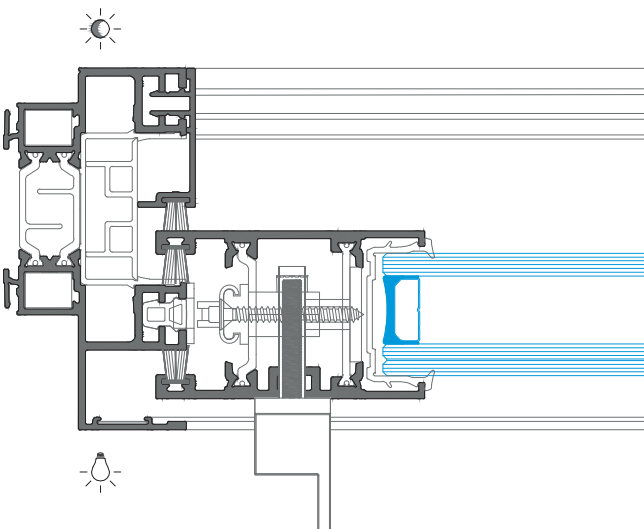
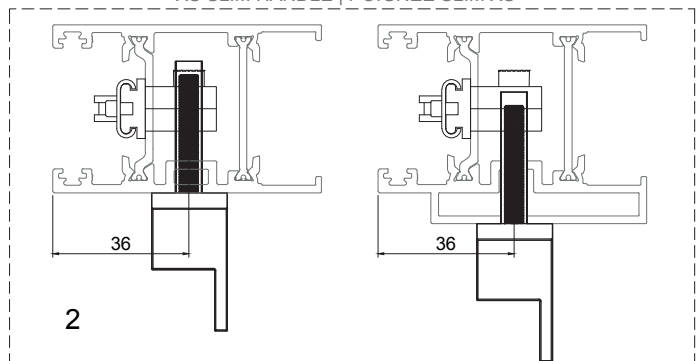

**MAQUINAÇÕES DOS PERFIS ARO MÓVEL JT**  
JT MOBILE FRAME PROFILES MACHINING  
USINAGE DES PROFILÉS OUVRANT JT

**14 - Ferragem Multiponto MAC ALU.**  
ALU MAC Multipoint Hardware.  
Serrure Multipoint MAC ALU.

**14.2 - Medidas e maquinações.**  
Measures and milling.  
Mesures et usinages.

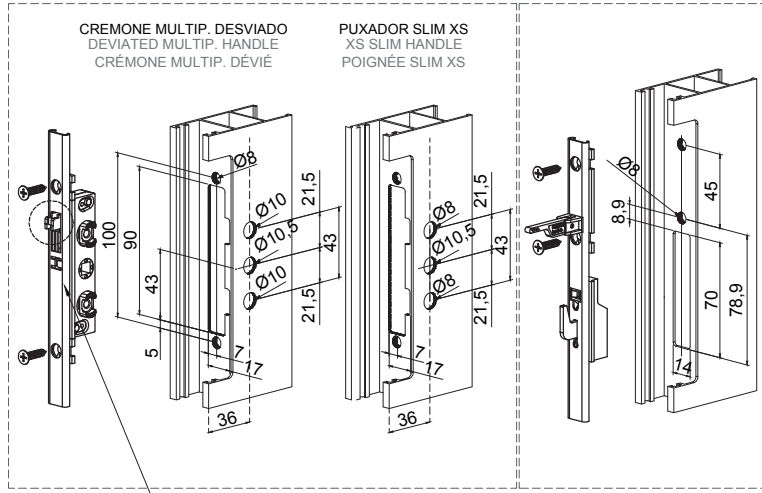

Aplicar batente 15x6 para acionamento da falsa manobra  
Apply a 15x6 stop to activate the false maneuver  
Appliquer un stop 15x6 pour activer la fausse manœuvre

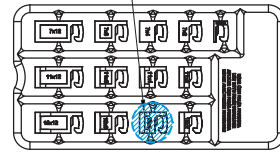
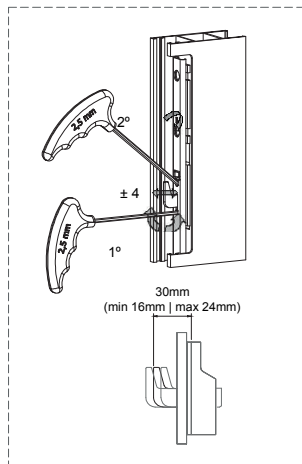

ACESSÓRIOS A CONSIDERAR POR FERRAGEM.: ACCESSORIES TO CONSIDER BY HARDWARE: ACCESSOIRES À CONSIDÉRER PAR LE SERRURE:				
Ref.	MAC.600 (2P)	MAC.1000 (2P)	MAC.1600 (3P)	MAC.1800 (4P)
200817   200819 200959   200939	1	1	1	1
212371	6	6	8	10
202330 (a) ou   ou   or 202331 (b)	2	2	3	4
212455 (a) ou   ou   or 212458 (b)	2	2	3	4

(a) Para tipologias de aro fixo.  
For fixed frame typologies. | Pour les types de châssis fixes.  
(b) Para tipologias de encontro no mesmo rail e canto.  
For meeting on the same rail and corner typologies. | Pour les typologies de réunion sur le même rail et d'angle.

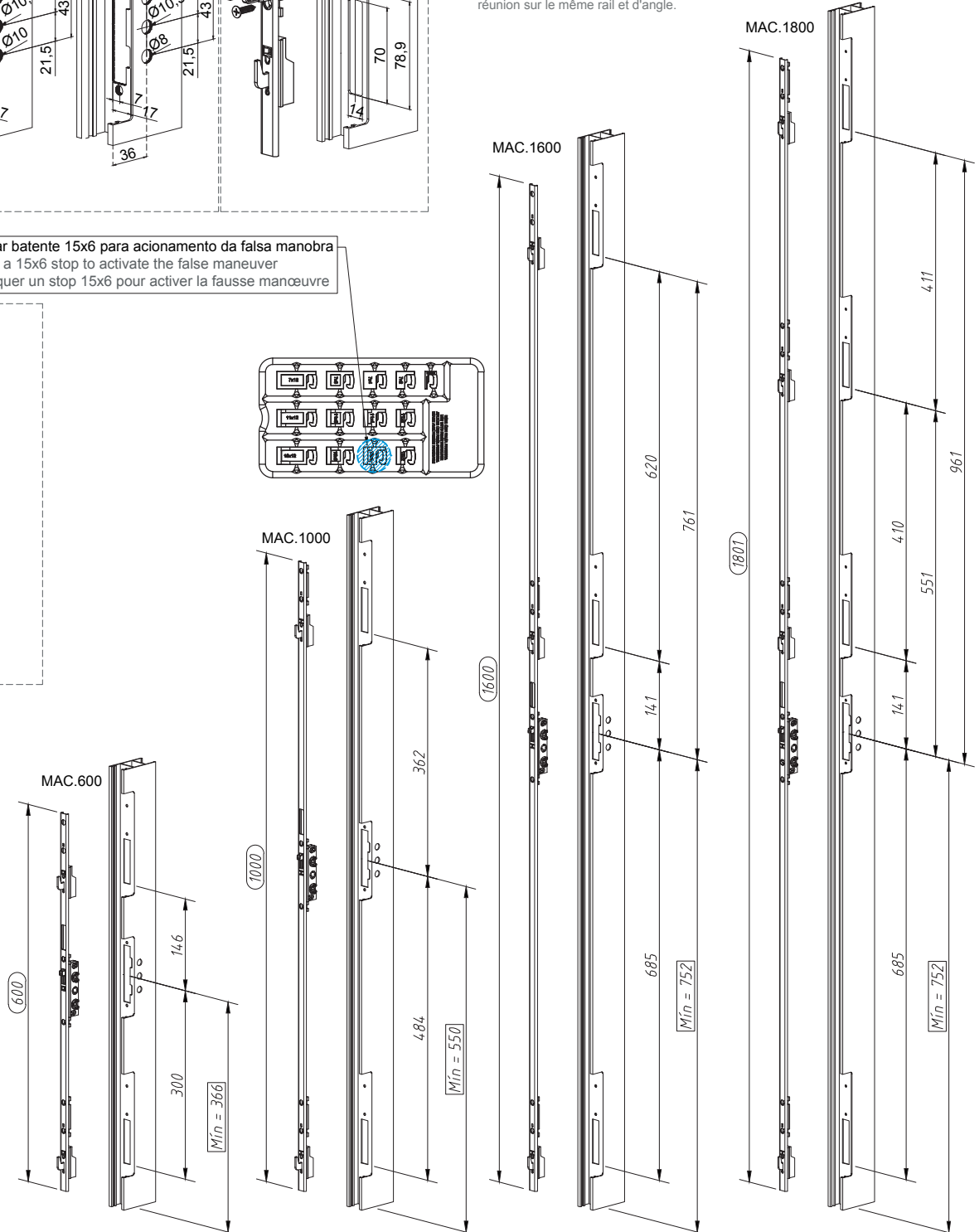

**MAQUINAÇÕES DOS PERFIS ARO MÓVEL JT**  
JT MOBILE FRAME PROFILES MACHINING  
USINAGE DES PROFILÉS OUVRANT JT

**15 - Ferragem Multiponto MACK ALU.**  
ALU MACK Multipoint Hardware.  
Serrure Multipoint MACK ALU.

**15.1 - Esquema de aplicação.**  
Application scheme.  
Schéma d'application.

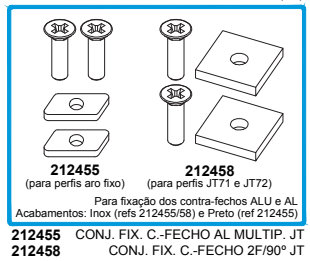
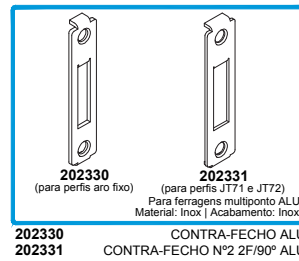
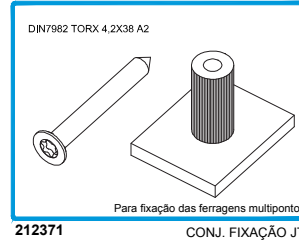
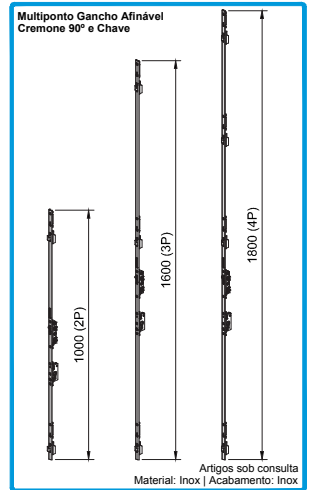
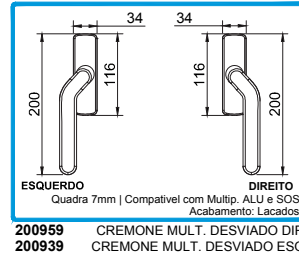
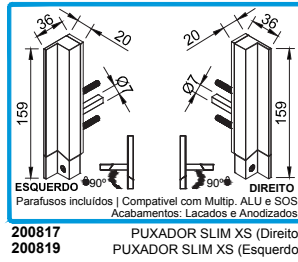
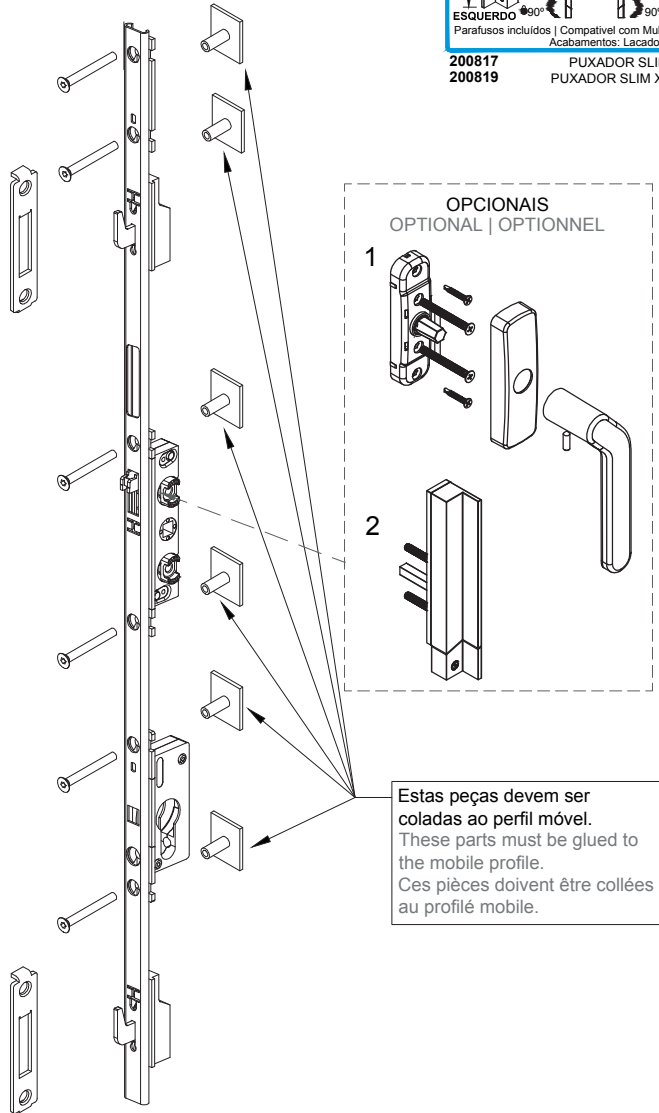

Estas peças devem ser coladas ao perfil móvel.  
These parts must be glued to the mobile profile.  
Ces pièces doivent être collées au profilé mobile.

**CREMONE MULTIPONTO DESVIADO**  
DEVIATED MULTIPOINT HANDLE | CRÉMONE MULTIPOINT DÉVIÉ

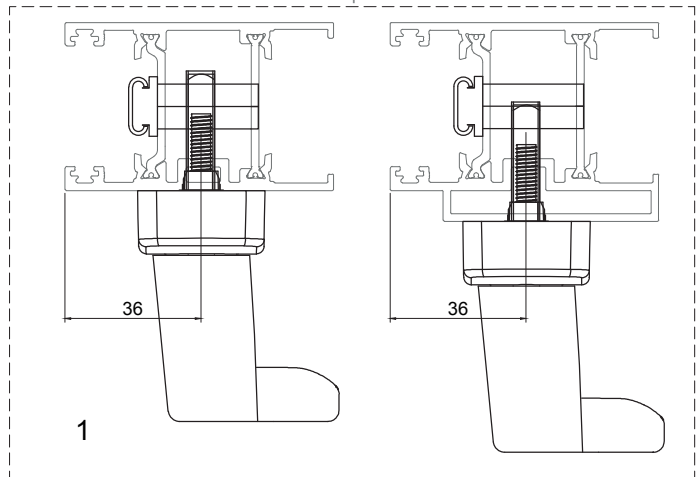

**PUXADOR SLIM XS**  
XS SLIM HANDLE | POIGNÉE SLIM XS

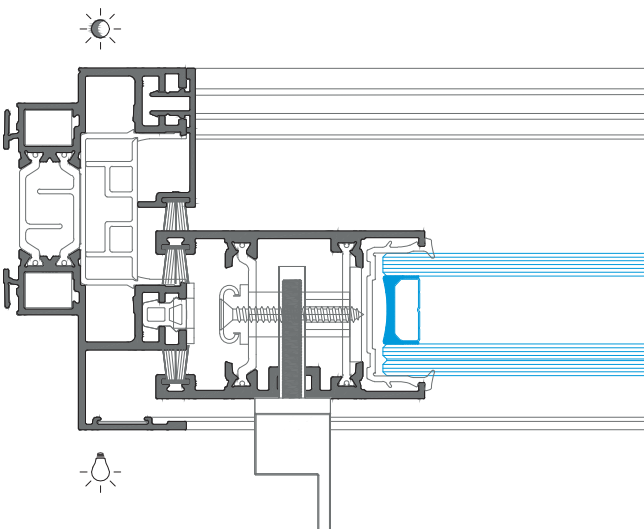
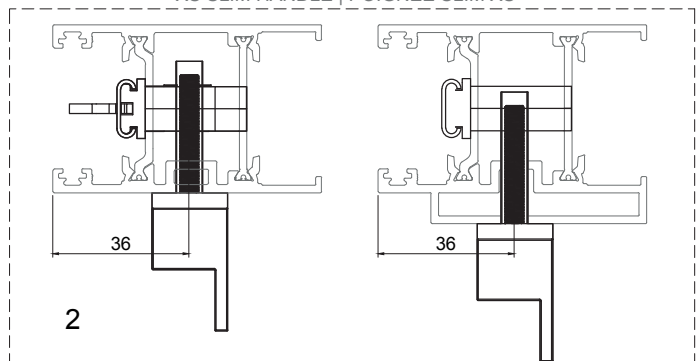



## MAQUINAÇÕES DOS PERFIS ARO MÓVEL JT

JT MOBILE FRAME PROFILES MACHINING

USINAGE DES PROFILÉS OUVRANT JT

### 15 - Ferragem Multiponto MACK ALU.

ALU MACK Multipoint Hardware.  
Serrure Multipoint MACK ALU.

### 15.2 - Medidas e maquinações.

Measures and milling.  
Mesures et usinages.

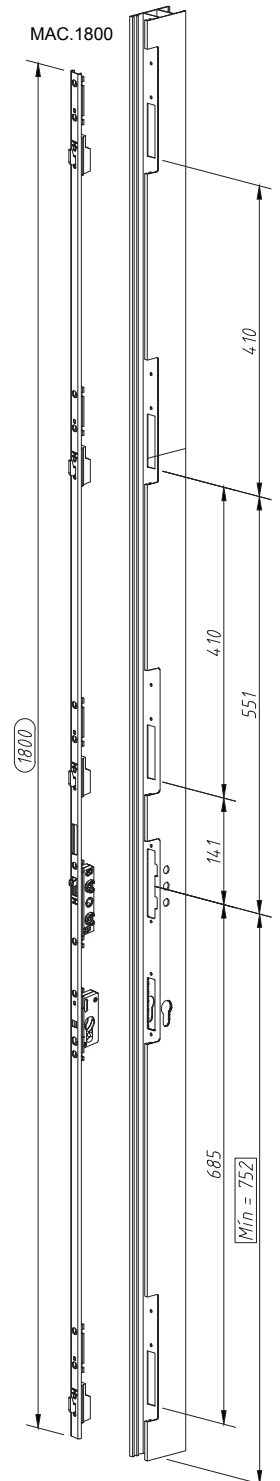
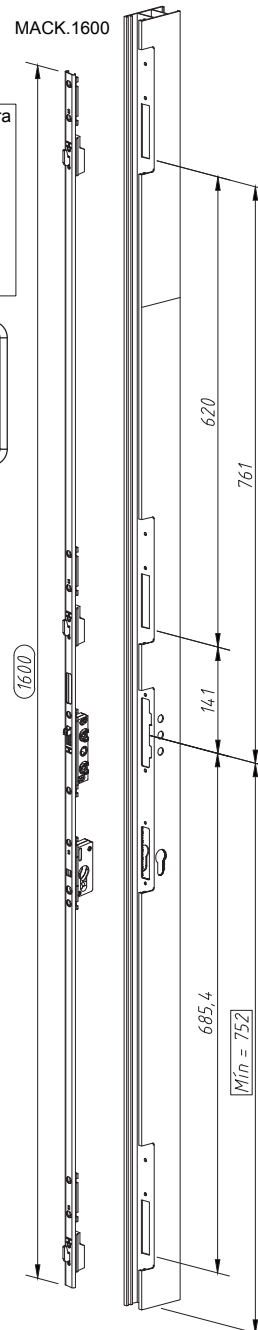
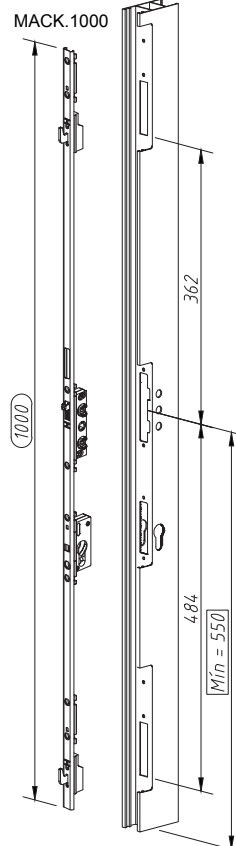
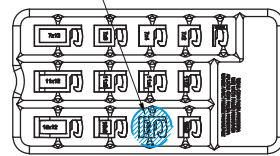
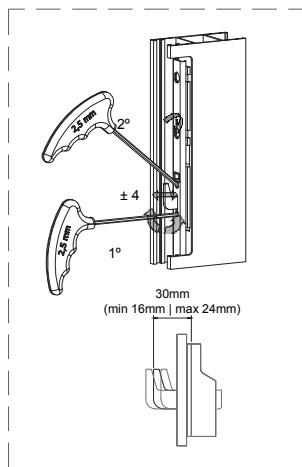
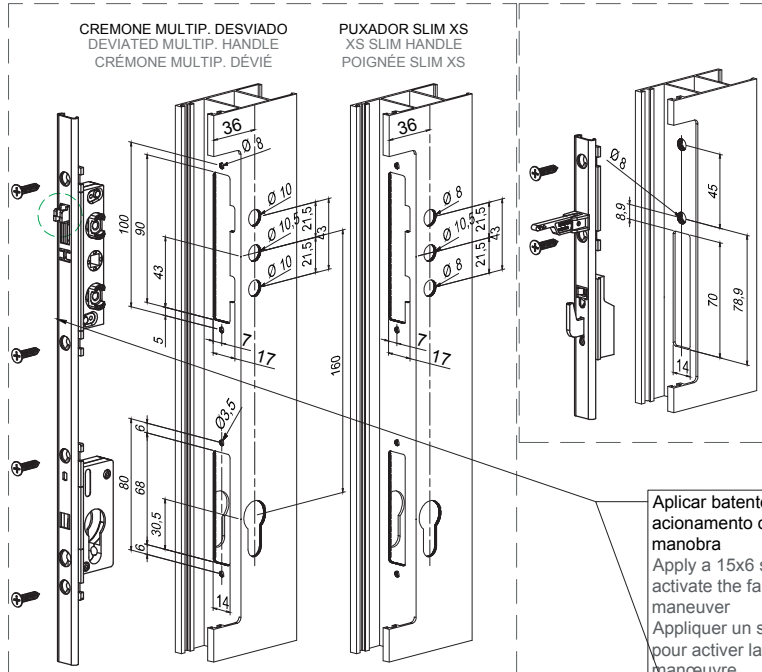

ACESSÓRIOS A CONSIDERAR POR FERRAGEM.: ACCESSORIES TO CONSIDER BY HARDWARE: ACCESSOIRES À CONSIDÉRER PAR LE SERRURE:			
Ref.	MAC.1000 (2P)	MAC.1600 (3P)	MAC.1800 (4P)
200817   200819 200959   200939	1	1	1
212371	8	10	12
202330 (a) ou   ou   or 202331 (b)	2	3	4
212455 (a) ou   ou   or 212458 (b)	2	3	4

(a) Para tipologias de aro fixo.

For fixed frame typologies. | Pour les types de châssis fixes.

(b) Para tipologias de encontro no mesmo rail e canto.

For meeting on the same rail and corner typologies. | Pour les typologies de réunion sur le même rail et d'angle.

**MAQUINAÇÕES DOS PERFIS ARO MÓVEL JT**  
JT MOBILE FRAME PROFILES MACHINING  
USINAGE DES PROFILÉS OUVRANT JT

**16 - Ferragens Multiponto MAE ALU, MAC ALU e MACK ALU.**  
MAE ALU, MAC ALU and MACK ALU Multipoint Hardwares.  
Serrures Multipoint MAE ALU, MAC ALU et MACK ALU.

**16.1 - Escolha do batente para falsa manobra.**  
False manouver stop choosing.  
Choisir d'arrêt pour fausse manœuvre.

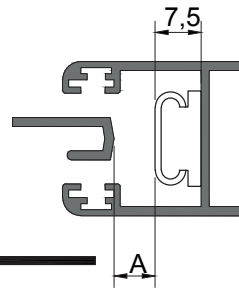
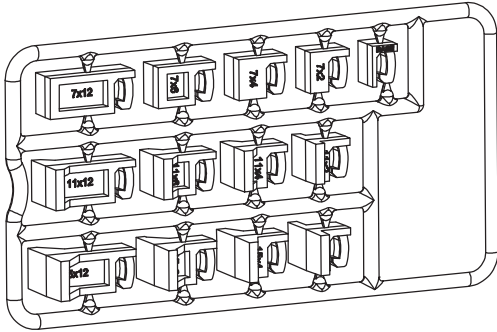

**Seleção do comprimento**  
Length selection  
La sélection de longueur

**Seleção da largura**  
Width selection  
La sélection de largeur

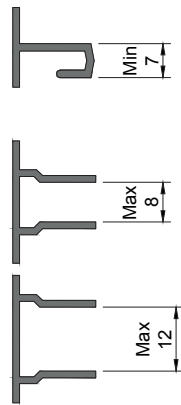

	Min.	Máx*	Min.	Máx*	Min.	Máx*	Min.	Máx*	Min.	Máx*
A =	12	17,5	6	12	4	10	2	8	0	4

**16.2 - Aplicação do batente para falsa manobra.**  
False manouver stop application.  
Application d'arrêt pour fausse manœuvre.

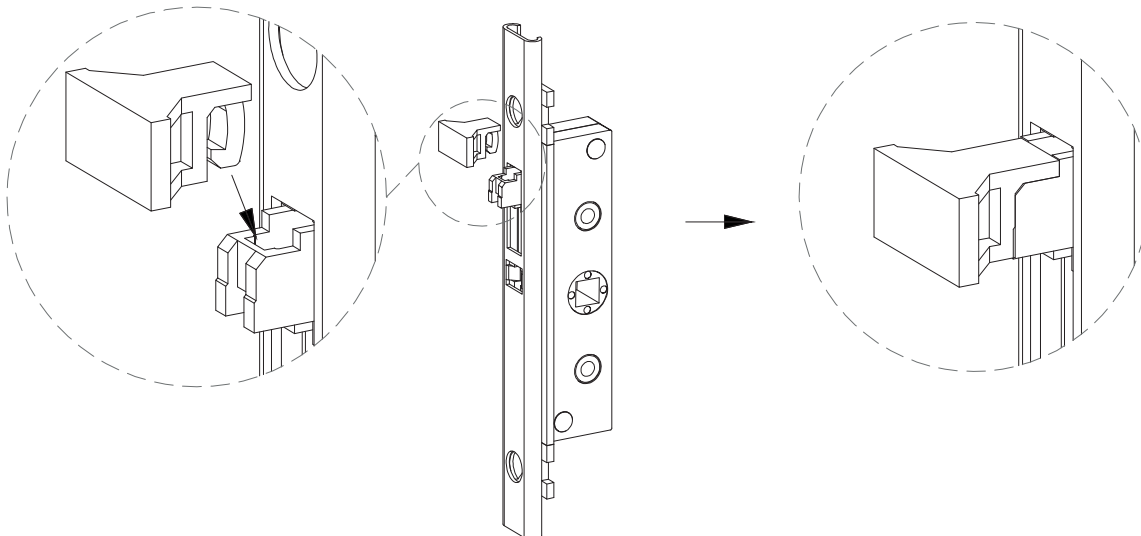

**MAQUINAÇÕES DOS PERFIS ARO MÓVEL JT**

JT MOBILE FRAME PROFILES MACHINING

USINAGE DES PROFILÉS OUVRANT JT

**17 - Ferragem Multiponto SOS para centrador.**

SOS Multipoint Hardware for centerer.  
Serrure Multipoint SOS pour centreur.

**17.1 - Esquema de aplicação.**

Application scheme.  
Schéma d'application.

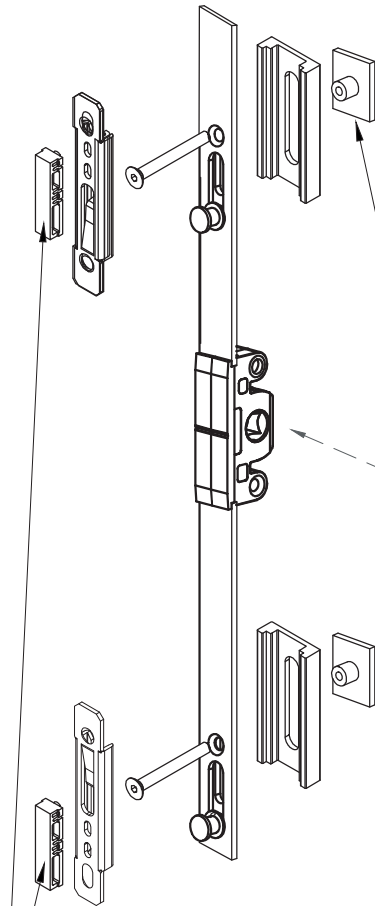

Estas peças devem ser coladas ao perfil móvel.  
These parts must be glued to the mobile profile.  
Ces pièces doivent être collées au profilé mobile.

Só se usa em aplicações no aro fixo  
(não funciona nos perfis de ligação)  
Only used in fixed frame applications  
(does not work in connection profiles)  
Utilisé uniquement dans les applications à dormant  
(ne fonctionne pas dans les profilés de connexion)

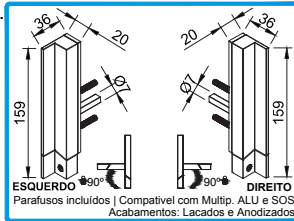

**200817** PUXADOR SLIM XS (Direito)  
**200819** PUXADOR SLIM XS (Esquerdo)

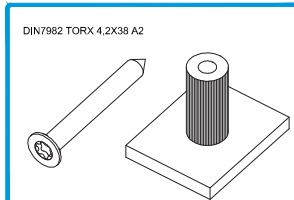

**212371** CONJ. FIXAÇÃO JT  
Para fixação das ferragens multiponto

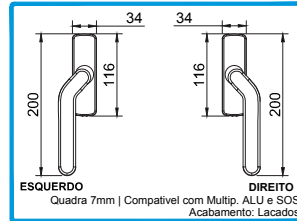
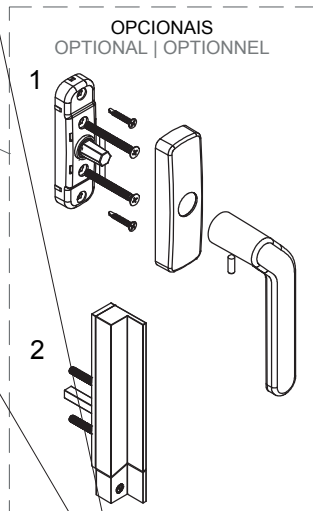

**200959** CREMONE MULT. DESVIADO DIR  
**200939** CREMONE MULT. DESVIADO ESQ

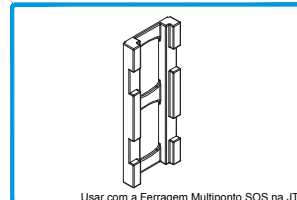

**218149** CALÇO N°2 P/MULTIP. SOS JT  
Usar com a Ferragem Multiponto SOS na JT  
Material: Poliamida | Acabamento: Preto

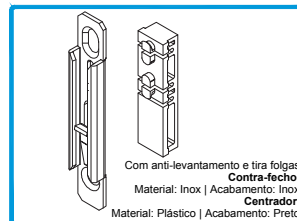

**202491** CONTRA-FECHO ANTI-LEV. MULT.  
**202487** CENTRADOR JT P/ C-FECHO AL M.

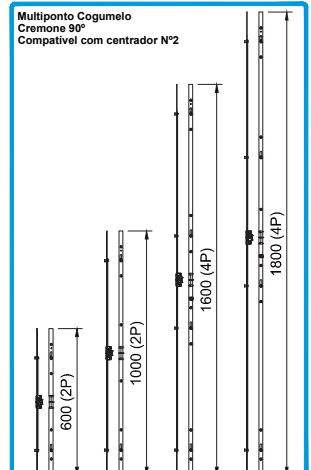

**211222** F. MULTIP. CENTR. 600 (2P)  
**211223** F. MULTIP. CENTR. 1000 (2P)  
**211224** F. MULTIP. CENTR. 1600 (4P)  
**211225** F. MULTIP. CENTR. 1800 (4P)  
Material: Inox | Acabamento: Inox

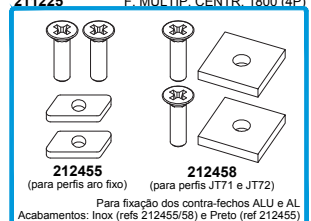

**212455** CONJ. FIX. C.-FECHO AL MULTIP. JT  
**212458** CONJ. FIX. C.-FECHO 2F/90° JT  
Para fixação dos contra-fechos ALU e AL  
Acabamentos: Inox (refs 212455/58) e Preto (ref 212455)

**CREMONE MULTIPONTO DESVIADO**  
DEVIATED MULTIPOINT HANDLE | CRÉMONE MULTIPOINT DÉVIÉ

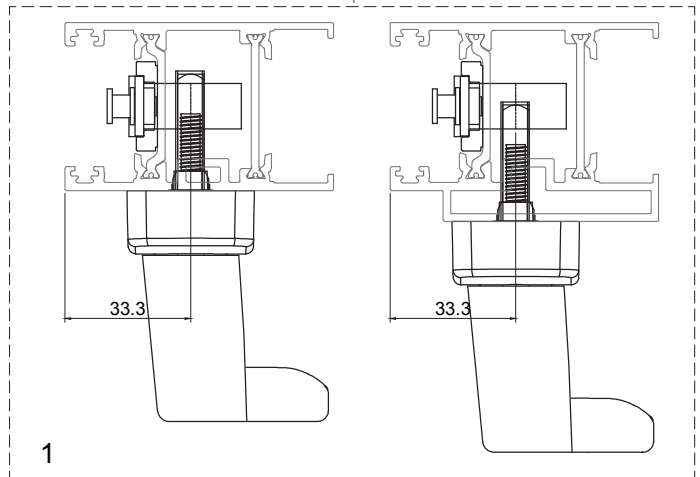

1

**PUXADOR SLIM XS**  
XS SLIM HANDLE | POIGNÉE SLIM XS

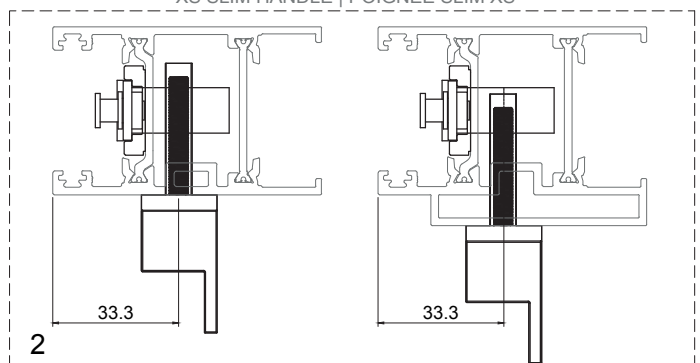

2

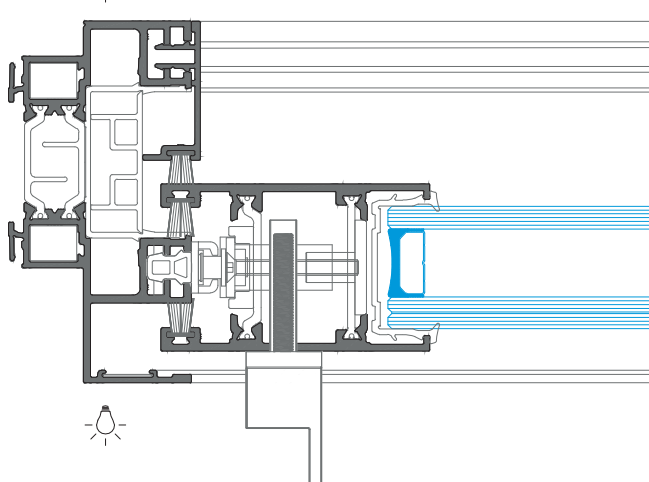

**MAQUINAÇÕES DOS PERFIS ARO MÓVEL JT**

JT MOBILE FRAME PROFILES MACHINING

USINAGE DES PROFILÉS OUVRANT JT

**17 - Ferragem Multiponto SOS para centrador.**

SOS Multipoint Hardware for centerer.

Serrure Multipoint SOS pour centreur.

**17.2 - Medidas e maquinações.**

Measures and milling.

Mesures et usinages.

CREM. MULTIP. DESV.  
DEVIATED MULT. HANDLE  
CRÉMONE MULTIP. DÉVIÉ

PUXADOR SLIM XS  
XS SLIM HANDLE  
POIGNÉE SLIM XS

FERRAGEM  
HARDWARE  
SERRURE

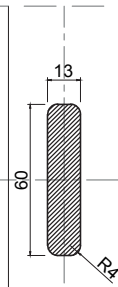
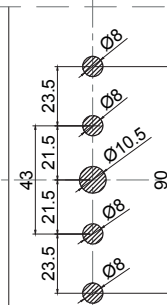
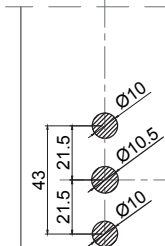
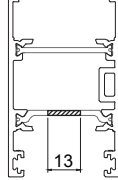
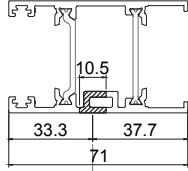
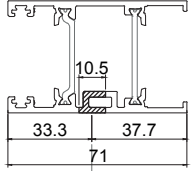

Eixo do cremone  
Handle axis  
Axe de crémone

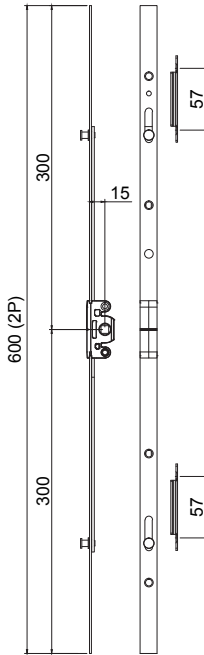

1000 (2P)

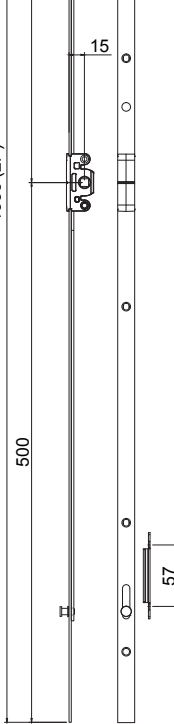

1600 (4P)

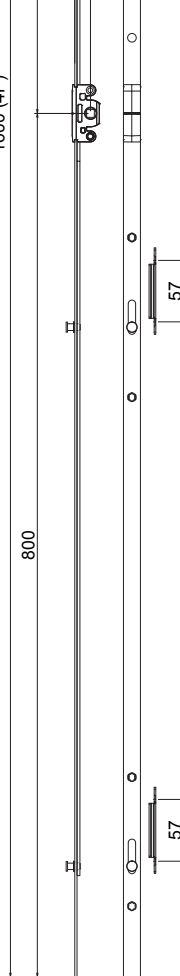

1800 (4P)

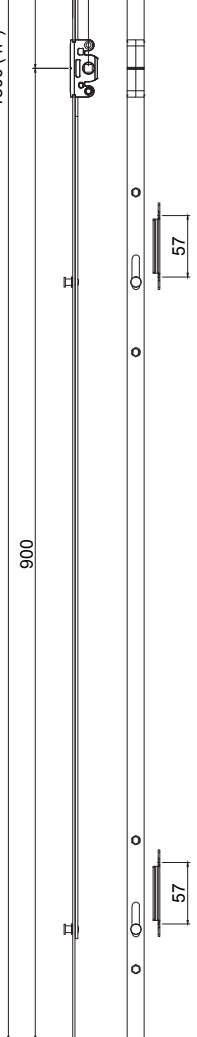

**ACESSÓRIOS A CONSIDERAR POR FERRAGEM MULTIP.:**  
**ACCESSORIES TO CONSIDER BY MULTIP. HARDWARE:**  
**ACCESSOIRES À CONSIDÉRER PAR LE SERRURE MULTIP.:**

Ref.	600 (2P)	1000 (2P)	1600 (4P)	1800 (4P)
200817   200819 ou   or   ou 200959   200939	1	1	1	1
218149	4	6	8	8
212371	4	6	8	8
202491	2	2	4	4
202487 (a)	2	2	4	4
212455 (a) ou   or   ou 212162 (b)	2	2	4	4
212161 ou   or   ou 212162	1 ou   or   ou 2*	1 ou   or   ou 2*	1 ou   or   ou 2*	1 ou   or   ou 2*

(a) Para tipologias de aro fixo.

For fixed frame typologies.

Pour les types de châssis fixes.

(b) Para tipologias de encontro no mesmo rail e canto.

For meeting on the same rail and corner typologies.

Pour les typologies de réunion sur le même rail et d'angle.

\* Ver tabela da página "Aplicação do centrador"

See table on page "Centering Part Application" | Voir tableau page "Application du Centreur"

**MAQUINAÇÕES DOS PERFIS ARO MÓVEL JT**

JT MOBILE FRAME PROFILES MACHINING

USINAGE DES PROFILÉS OUVRANT JT

17 - Ferragem Multiponto SOS para centrador.

SOS Multipoint Hardware for centerer.

Serrure Multipoint SOS pour centreur.

17.3 - Características dos pontos de fecho.

Locking points characteristics.

Caractéristiques des points de fermeture.

**PONTO DE FECHO SUPERIOR**  
TOP LOCKING POINT  
POINT DE VERROUILLAGE SUPÉRIEUR

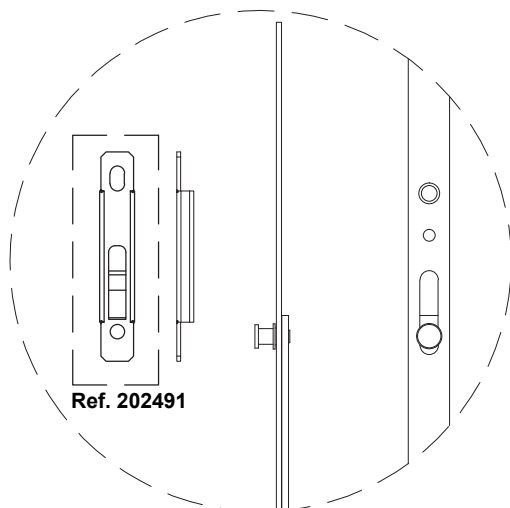

**PONTO DE FECHO CENTRAL OU INFERIOR**  
CENTRAL OR BOTTOM LOCKING POINT  
POINT DE VERROUILLAGE CENTRAL OU INFÉRIEUR

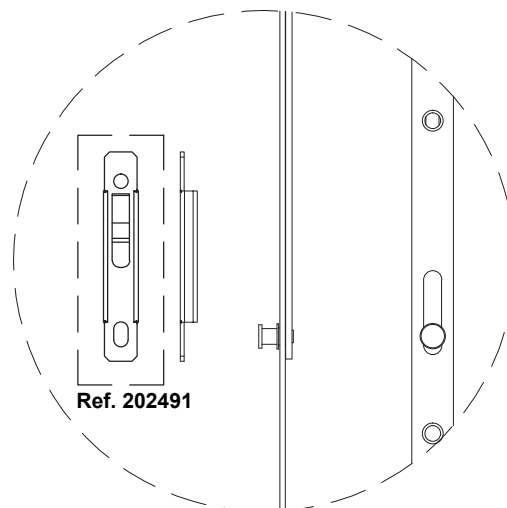

**CONTRA-FECHO COM FUNÇÃO ANTI-LEVANTAMENTO**

(Rampa na zona inferior do contra-fecho)

**LOCKING PLATE WITH ANTI-LEAF FUNCTION**

(Ramp in the lower zone of the locking plate)

**CONTRE-FERMETURE AVEC FONCTION ANTI-LIFTING**

(Rampe en bas de la contre-serrure)

**CONTRA-FECHOS SEM FUNÇÃO DE ANTI-LEVANTAMENTO**

(Rampas nas zonas superiores dos contra-fechos)

**LOCKING PLATE WITHOUT ANTI-LEAF FUNCTION**

(Ramps in the lower zones of the locking plate)

**FERMETURE SANS FONCTION ANTI-LEVAGE**

(Rampes dans les zones supérieures des casiers)

**IMPORTANTE | IMPORTANT | IMPORTANT:**

**Apenas 1 unidade por prumada.**

**Only 1 unit per lateral.**

**Seulement 1 unité pour l'atéral.**

17.4 - Aplicação do centrador.

Centering part application.

Application du centreur.

	EXPOSIÇÃO 1 EXPOSURE 1   EXPOSITION 1		EXPOSIÇÃO 2 EXPOSURE 2   EXPOSITION 2	
	COR COLOR   COULEUR		COR COLOR   COULEUR	
ALTURA HIGH   HAUTEUR	CLARO BRIGHT   CLAIRE	ESCURO DARK   FONCÉE	CLARO BRIGHT   CLAIRE	ESCURO DARK   FONCÉE
H ≤ 1500	0	0	0	1
1500 < H ≤ 1750	0	1	1	2
1750 < H ≤ 2000	1	2	2	2
H > 2000	2	2	2	2

Exposição 1 = Norte, Noroeste, Nordeste  
Exposure 1 = North, North-West, North-East  
Exposition 1 = Nord, Nord-Ouest, Nord-Est

Exposição 2 = Sul, Sudeste, Sudoeste  
Exposure 2 = South, South-East, South-West  
Exposition 2 = Sud, Sud-Est, Sud-Ouest

**MAQUINAÇÕES DOS PERFIS ARO MÓVEL JT**

JT MOBILE FRAME PROFILES MACHINING

USINAGE DES PROFILÉS OUVRANT JT

**17 - Ferragem Multiponto SOS para centrador.**

SOS Multipoint Hardware for centerer.  
Serrure Multipoint SOS pour centreur.

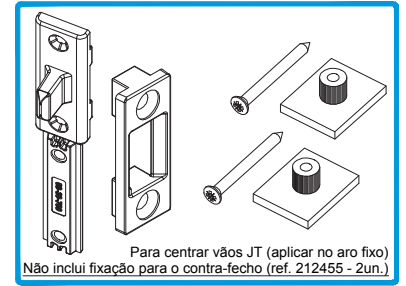
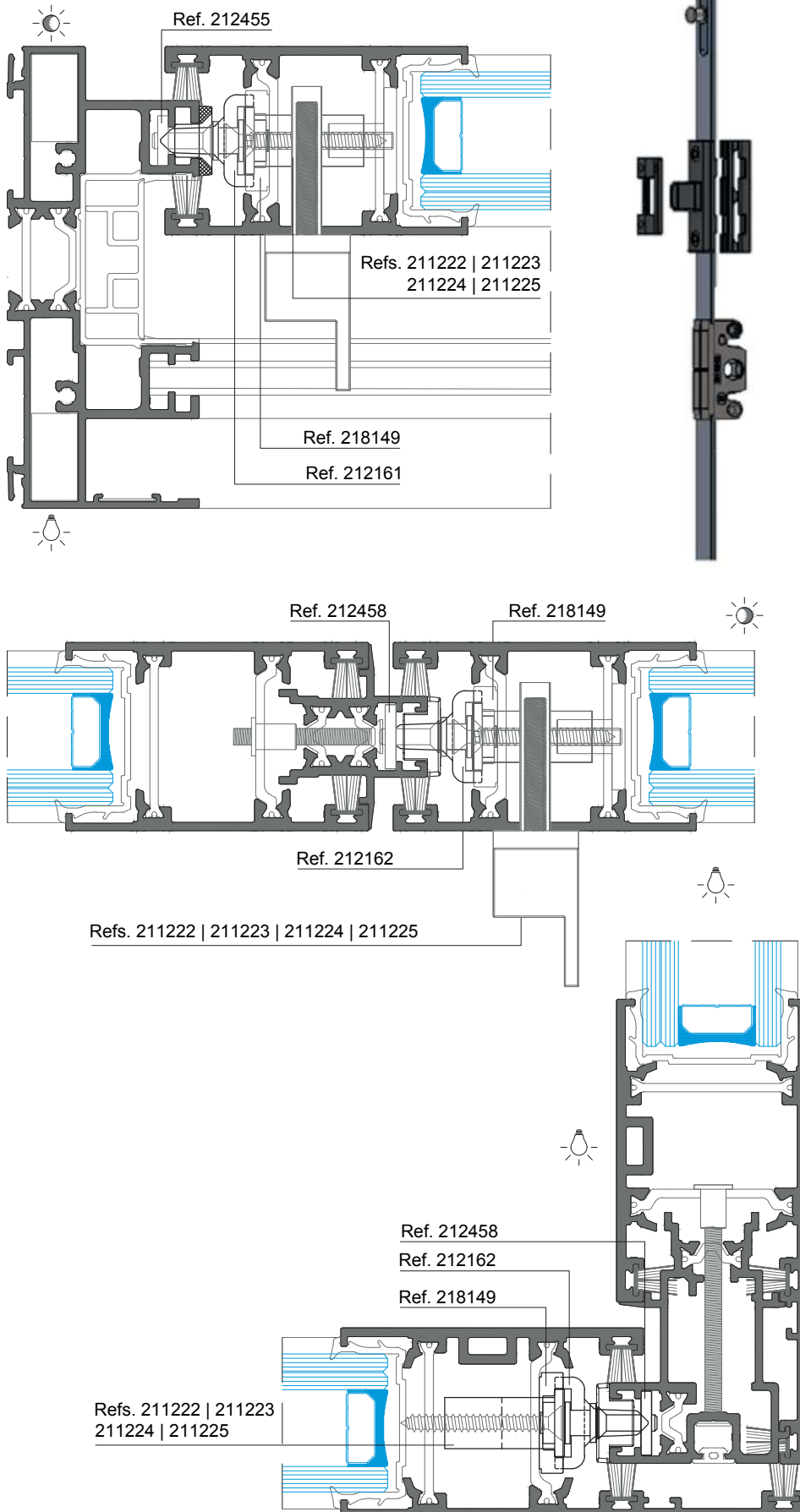

**212161** CONJ. CENTRADOR P/ FERRAGEM JT

Para centrar vãos JT (aplicar no aro fixo)  
Não inclui fixação para o contra-fecho (ref. 212455 - 2un.)

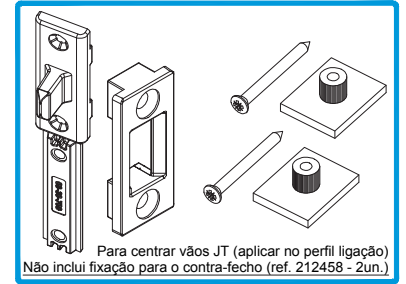

**212162** CONJ. CENTRADOR P/ FERRAGEM JT PERFIL LIG.

Para centrar vãos JT (aplicar no perfil ligação)  
Não inclui fixação para o contra-fecho (ref. 212458 - 2un.)

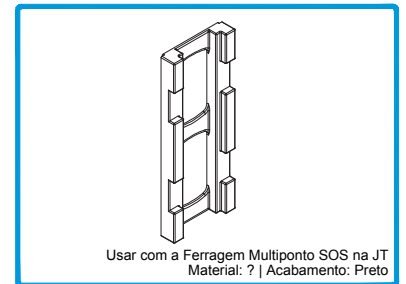

**218149** CALÇO Nº2 P/ MULTIP. SOS JT

Usar com a Ferragem Multiponto SOS na JT  
Material: ? | Acabamento: Preto

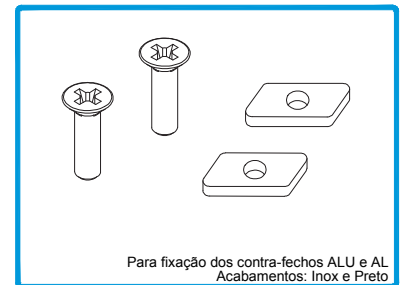

**212455** CONJ. FIX. CONTRA-FECHO AL MULTIP. JT

Para fixação dos contra-fechos ALU e AL  
Acabamentos: Inox e Preto

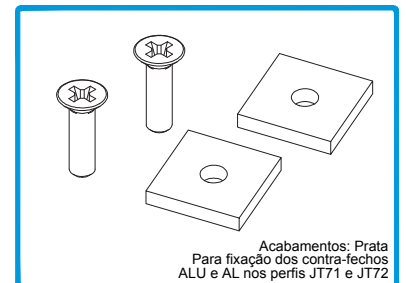

**212458** CONJ. FIX. CONTRA-FECHO 2F/90° JT

Acabamentos: Prata  
Para fixação dos contra-fechos ALU e AL nos perfis JT71 e JT72



**MAQUINAÇÕES DOS PERFIS ARO MÓVEL JT**  
JT MOBILE FRAME PROFILES MACHINING  
USINAGE DES PROFILÉS OUVRANT JT

**18 - Ferragem Multiponto SOS para centrador e micro-ventilação.**  
SOS Multipoint Hardware for centerer and micro-ventilation.  
Serrure Multipoint SOS pour centreur et micro-ventilation.

**18.1 - Esquema de aplicação.**  
Application scheme.  
Schéma d'application.

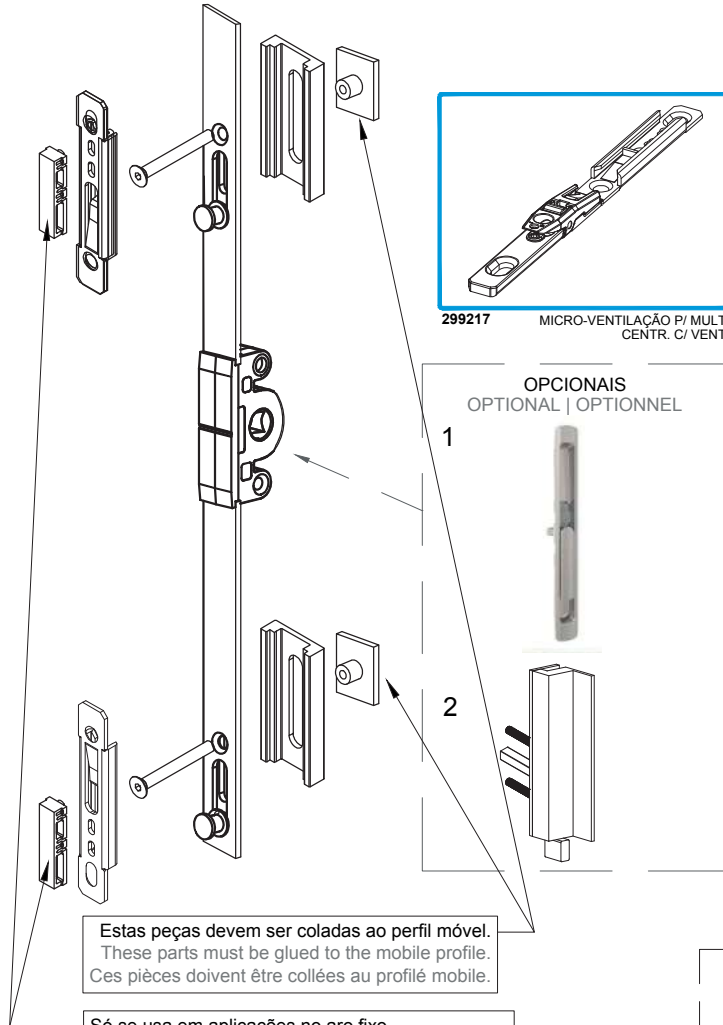

Só se usa em aplicações no aro fixo  
(não funciona nos perfis de ligação)  
(does not work in connection profiles)  
Utilisé uniquement dans les applications à dormant  
(ne fonctionne pas dans les profilés de connexion)

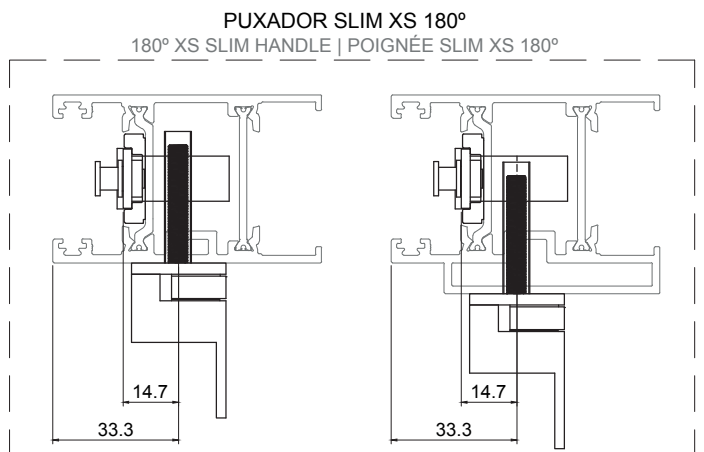
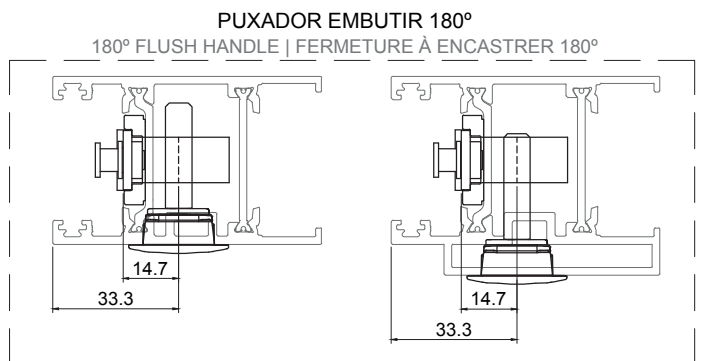
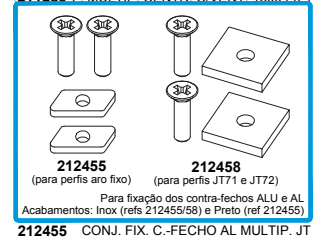
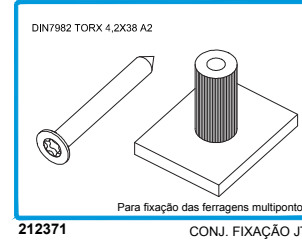
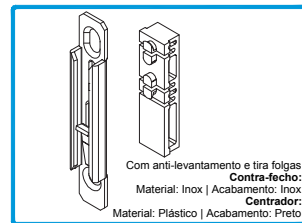
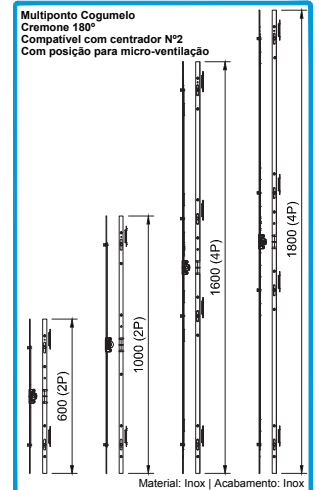
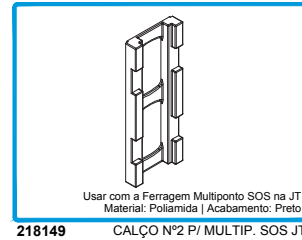
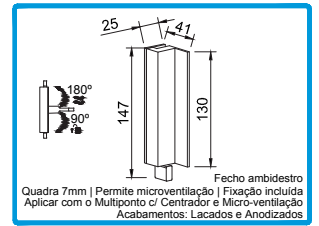
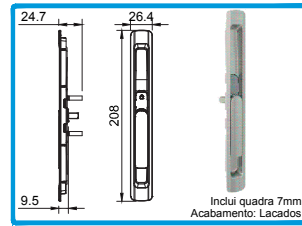
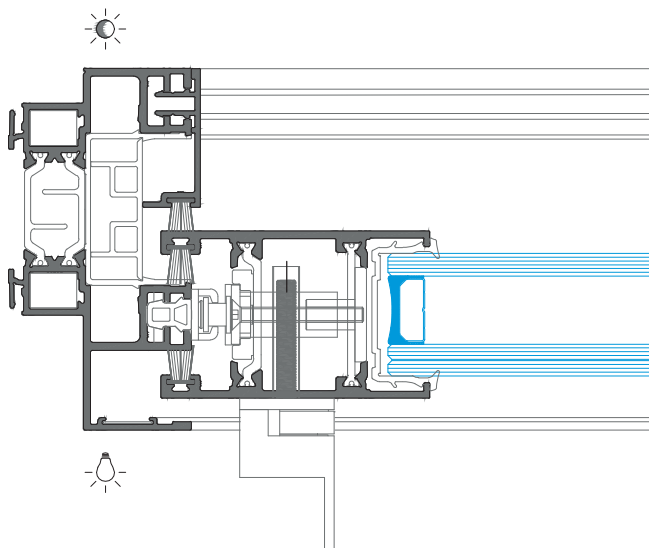

**MAQUINAÇÕES DOS PERFIS ARO MÓVEL JT**

JT MOBILE FRAME PROFILES MACHINING

USINAGE DES PROFILÉS OUVRANT JT

**18 - Ferragem Multiponto SOS para centrador e micro-ventilação.**

SOS Multipoint Hardware for centerer and micro-ventilation.

Serrure Multipoint SOS pour centreur et micro-ventilation.

**18.2 - Medidas e maquinações.**

Measures and milling.

Mesures et usinages.

**FECHO DE EMBUTIR 180°**  
180° BUILT-IN LOCK  
SERRURE INTÉGRÉE À 180°

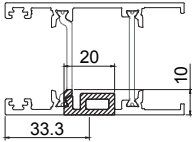

**PUXADOR SLIM XS 180°**  
180° XS SLIM HANDLE  
POIGNÉE SLIM XS 180°

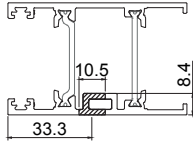

**FERRAGEM HARDWARE**  
SERRURE

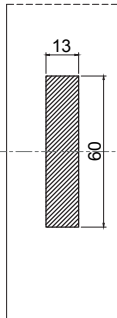
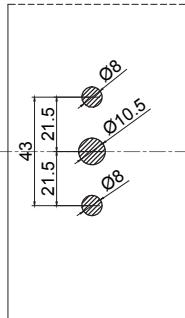
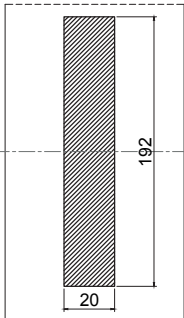
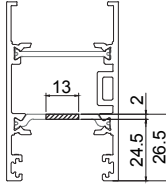

Eixo da quadra  
Spindle axis  
Axe de tige

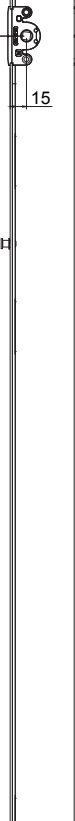
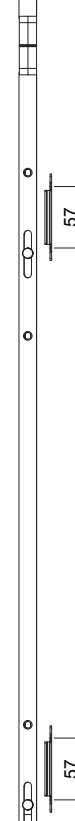
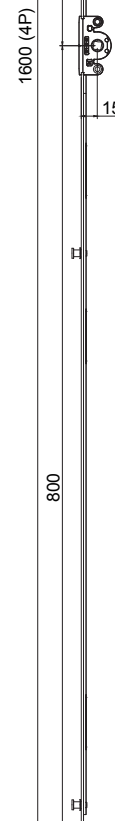
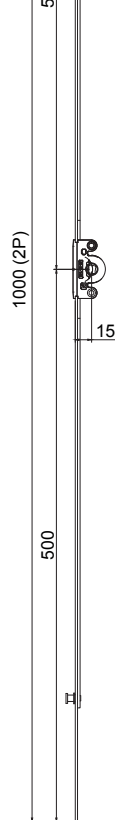
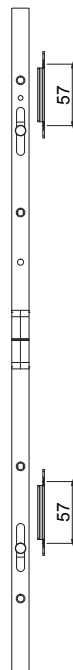
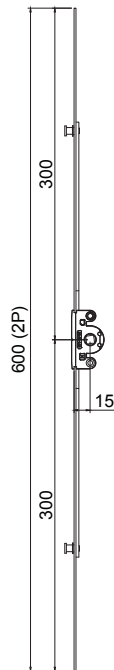

**ACESSÓRIOS A CONSIDERAR POR FERRAGEM MULTIP.:  
ACCESSORIES TO CONSIDER BY MULTIP. HARDWARE:  
ACCESSOIRES À CONSIDÉRER PAR LE SERRURE MULTIP.:**

Ref.	600 (2P)	1000 (2P)	1600 (4P)	1800 (4P)
201083	1	1	1	1
218149	4	6	8	8
212371	4 + 2	6 + 2	8 + 2	8 + 2
202491	2	2	4	4
202487 (a)	2	2	4	4
212455 (a) ou   or   ou 212162 (b)	2	2	4	4
212161 ou   or   ou 212162	1 ou   or   ou 2 *	1 ou   or   ou 2 *	1 ou   or   ou 2 *	1 ou   or   ou 2 *
299217	1	1	1	1

(a) Para tipologias de aro fixo.

For fixed frame typologies.

Pour les types de châssis fixes.

(b) Para tipologias de encontro no mesmo raíl e canto.

For meeting on the same rail and corner typologies.

Pour les typologies de réunion sur le même raíl et d'angle.

**\* Ver tabela da página "Aplicação do centrador"**

See table on page "Centering Part Application"

Voir tableau page "Application du Centreur"

**MAQUINAÇÕES DOS PERFIS ARO MÓVEL JT**

JT MOBILE FRAME PROFILES MACHINING

USINAGE DES PROFILÉS OUVRANT JT

**18 - Ferragem Multiponto SOS para centrador e micro-ventilação.**

SOS Multipoint Hardware for centerer and micro-ventilation.

Serrure Multipoint SOS pour centeur et micro-ventilation.

**18.3 - Características dos pontos de fecho.**

Locking points characteristics.

Caractéristiques des points de fermeture.

**PONTO DE FECHO SUPERIOR**  
TOP LOCKING POINT  
POINT DE VERROUILLAGE SUPÉRIEUR

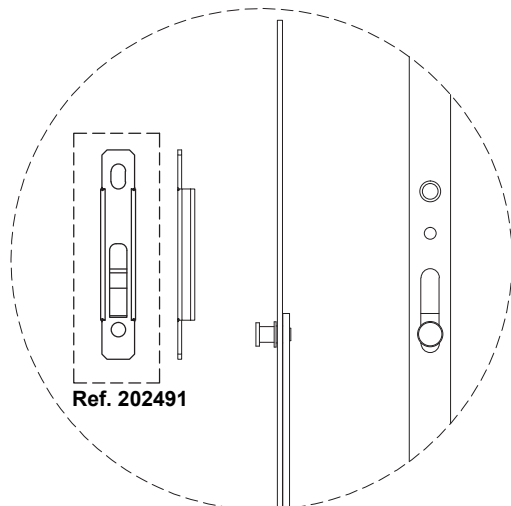

**PONTO DE FECHO CENTRAL OU INFERIOR**  
CENTRAL OR BOTTOM LOCKING POINT  
POINT DE VERROUILLAGE CENTRAL OU INFÉRIEUR

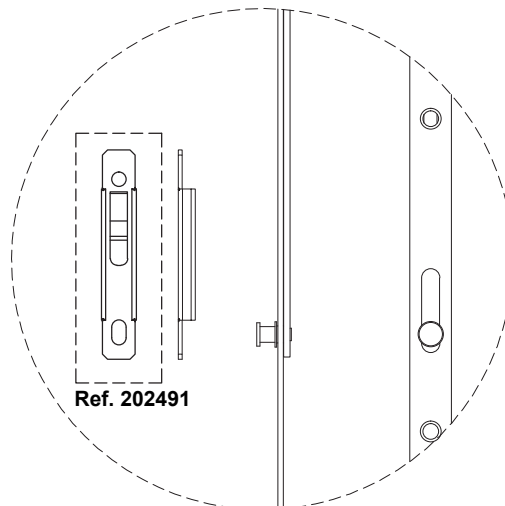

**CONTRA-FECHO COM FUNÇÃO ANTI-LEVANTAMENTO**

(Rampa na zona inferior do contra-fecho)

**LOCKING PLATE WITH ANTI-LEAF FUNCTION**

(Ramp in the lower zone of the locking plate)

**CONTRE-FERMETURE AVEC FONCTION ANTI-LIFTING**

(Rampe en bas de la contre-serrure)

**CONTRA-FECHOS SEM FUNÇÃO DE ANTI-LEVANTAMENTO**

(Rampas nas zonas superiores dos contra-fechos)

**LOCKING PLATE WITHOUT ANTI-LEAF FUNCTION**

(Ramps in the upper zones of the locking plate)

**FERMETURE SANS FONCTION ANTI-LEVAGE**

(Rampes dans les zones supérieures des casiers)

**IMPORTANTE | IMPORTANT | IMPORTANT:**

**Apenas 1 unidade por prumada.**

**Only 1 unit per lateral.**

**Seulement 1 unité pour latéral.**

**18.4 - Aplicação do centrador.**

Centering part application.

Application du centreur.

	EXPOSIÇÃO 1 EXPOSURE 1   EXPOSITION 1		EXPOSIÇÃO 2 EXPOSURE 2   EXPOSITION 2	
	COR COLOR   COULEUR		COR COLOR   COULEUR	
ALTURA HIGH   HAUTEUR	CLARO BRIGHT   CLAIRE	ESCURO DARK   FONCÉE	CLARO BRIGHT   CLAIRE	ESCURO DARK   FONCÉE
H ≤ 1500	0	0	0	1
1500 < H ≤ 1750	0	1	1	2
1750 < H ≤ 2000	1	2	2	2
H > 2000	2	2	2	2

Exposição 1 = Norte, Noroeste, Nordeste  
Exposure 1 = North, North-West, North-East  
Exposition 1 = Nord, Nord-Ouest, Nord-Est

Exposição 2 = Sul, Sudeste, Sudoeste  
Exposure 2 = South, South-East, South-West  
Exposition 2 = Sud, Sud-Est, Sud-Ouest

**MAQUINAÇÕES DOS PERFIS ARO MÓVEL JT**

JT MOBILE FRAME PROFILES MACHINING

USINAGE DES PROFILÉS OUVRANT JT

**18 - Ferragem Multiponto SOS para centrador e micro-ventilação.**

SOS Multipoint Hardware for centerer and micro-ventilation.

Serrure Multipoint SOS pour centeur et micro-ventilation.

**18.5 - Características da micro-ventilação.**

Microventilation characteristics.

Caractéristiques de la microventilation.

**POSIÇÕES DE ABERTURA**  
OPENING POSITIONS | POSITIONS D'OUVERTURE

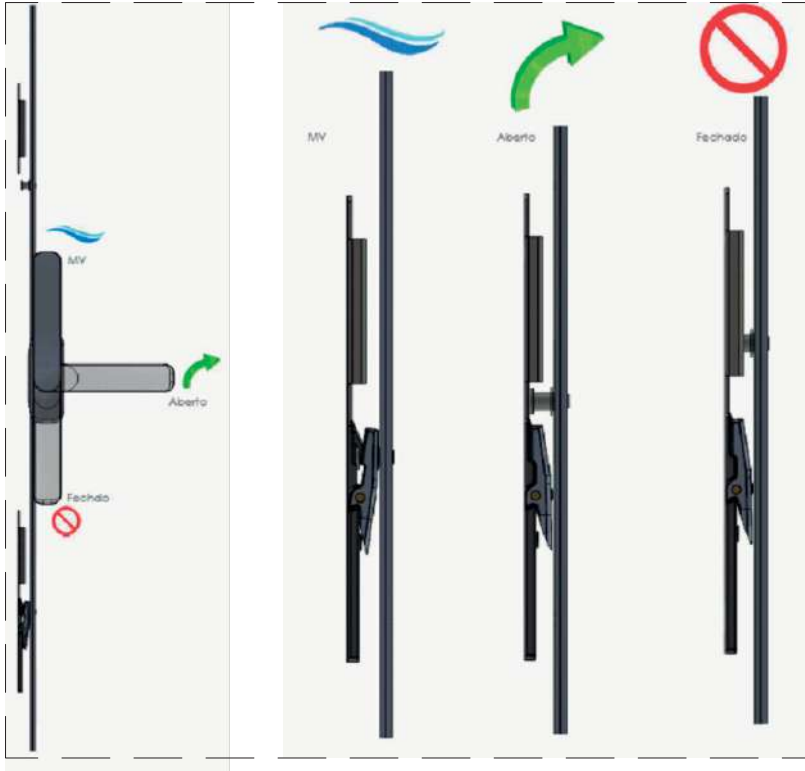

**REGULAÇÃO**  
REGULATION | RÉGULATION



**REGULAÇÃO**

REGULATION | RÉGULATION

Permite abrir de 6mm a 9mm, com recurso a uma chave Allen de 2,5mm.

Allows opening from 6mm to 9mm, using a 2.5mm Allen key.

Permet une ouverture de 6 mm à 9 mm, à l'aide d'une clé Allen de 2,5 mm.

**CERTIFICAÇÃO E ENSAIOS**

CERTIFICATION AND TESTS | CERTIFICATIONS ET ESSAIS

O produto está a ser certificado segundo a norma UNE 12207:2000 CLASSE 1. Foram realizados ensaios internos de tracção no fornecedor e os resultados estão abaixo.

The product is being certified according to the UNE 12207:2000 CLASS 1 standard. Traction tests were carried out at the supplier and the results are below.

Le produit est en cours de certification selon la norme UNE 12207:2000 CLASSE 1. Des tests de traction ont été effectués chez le fournisseur et les résultats sont ci-dessous.

Resistência à tracção Tensile strength   Résistance à la traction	
Contra-fecho Striking Plate   Contre-fermeture	Contra-fecho microventilação Microventilation striking plate   Contre-fermeture pour microventilation
204 kg	95 kg

**MAQUINAÇÕES DOS PERFIS ARO MÓVEL JT**  
JT MOBILE FRAME PROFILES MACHINING  
USINAGE DES PROFILÉS OUVRANT JT

**18 - Ferragem Multiponto SOS para centrador e micro-ventilação.**  
SOS Multipoint Hardware for centerer and micro-ventilation.  
Serrure Multipoint SOS pour centreur et micro-ventilation.

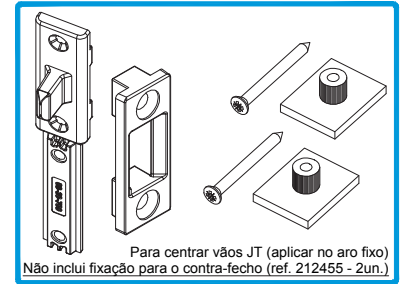
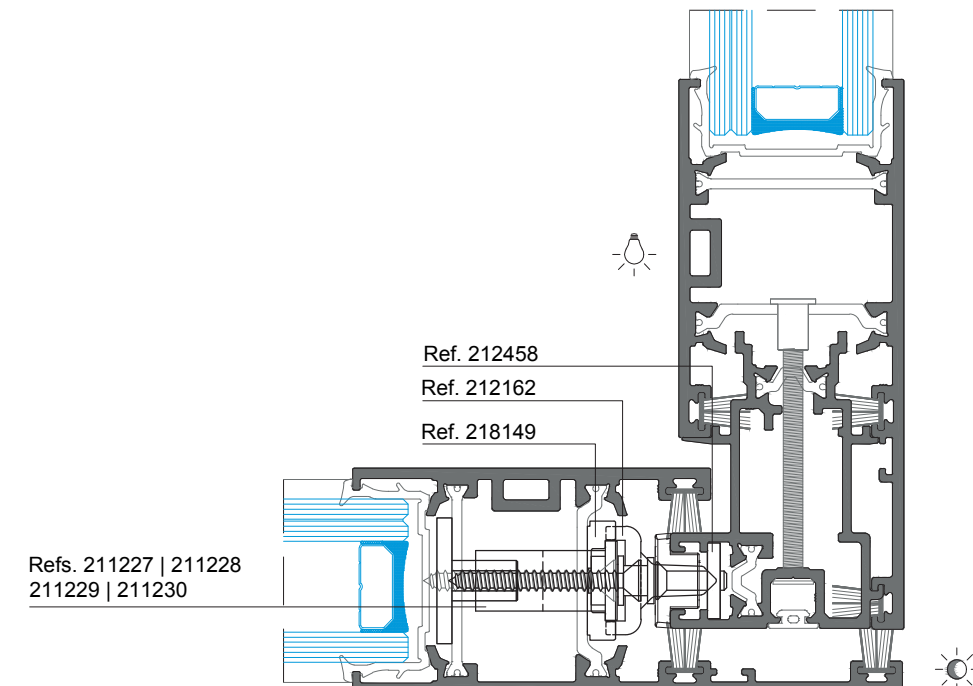
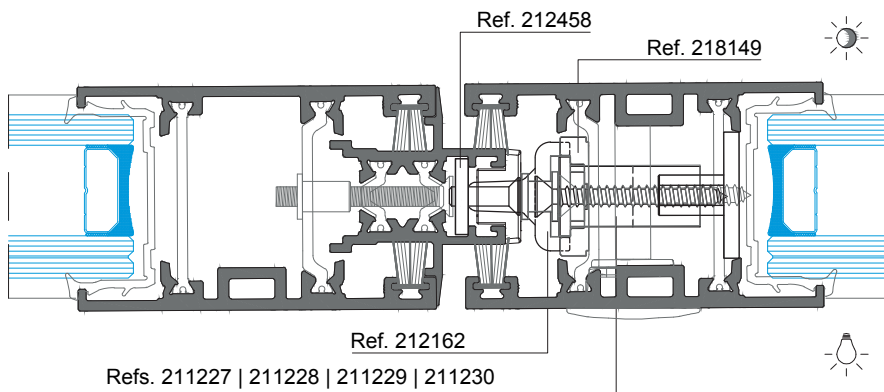
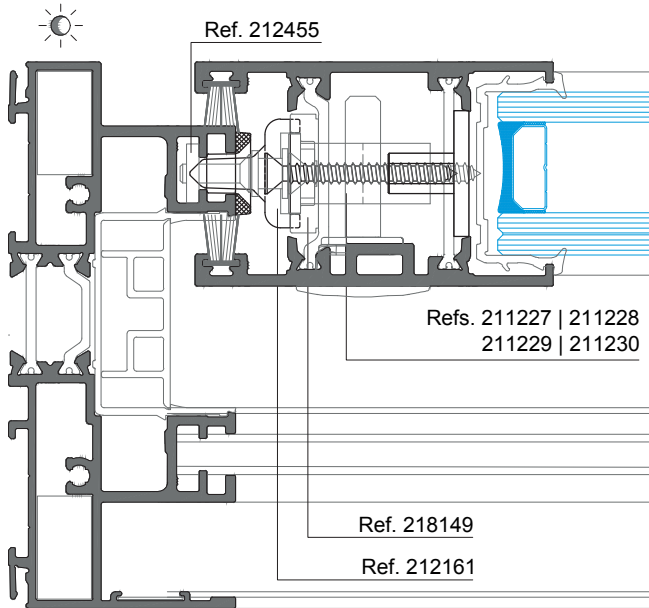

**212161** CONJ. CENTRADOR P/ FERRAGEM JT

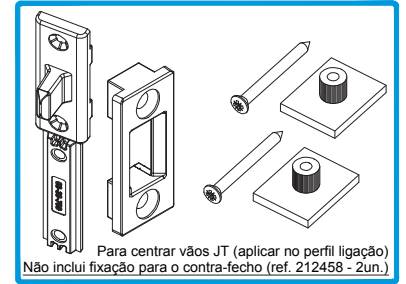

**212162** CONJ. CENTRADOR P/ FERRAGEM JT PERFIL LIG.

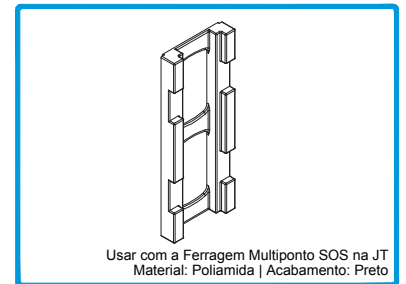

**212149** CALÇO Nº2 P/ MULTIP. SOS JT

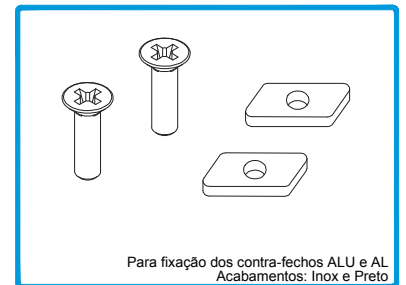

**212455** CONJ. FIX. CONTRA-FECHO AL MULTIP. JT

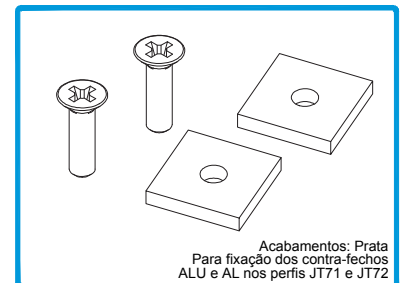

**212458** CONJ. FIX. CONTRA-FECHO 2F/90° JT

**MAQUINAÇÕES DOS PERFIS ARO MÓVEL JT**

JT MOBILE FRAME PROFILES MACHINING

USINAGE DES PROFILÉS OUVRANT JT

**19 - Ferragem Multiponto SOT.**

SOT Multipoint Hardware.  
Serrure Multipoint SOT.

**19.1 - Esquema de aplicação.**

Application scheme.  
Schéma d'application.

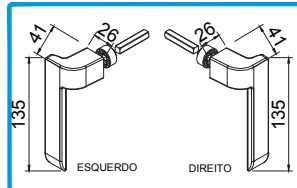
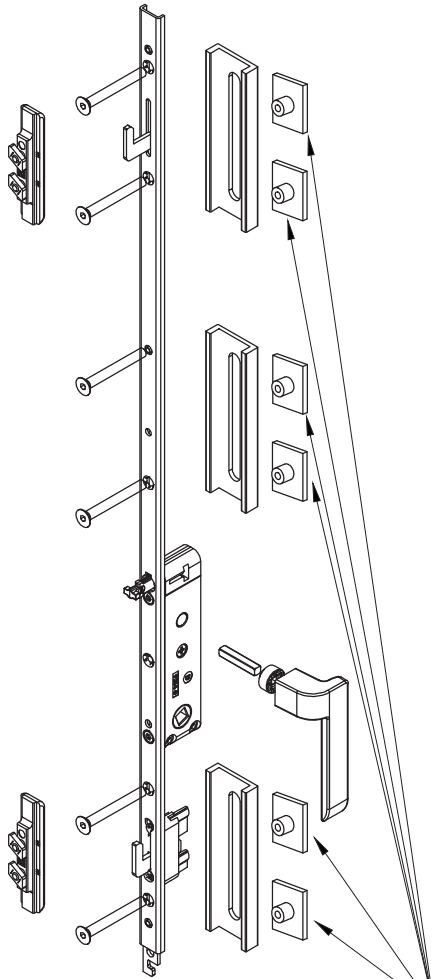

Compatível com ferragem multip. Chronos Evo  
Acabamentos: Lacados  
**200238** CREAM. MULTIP. MINIMALISTA  
NOVEM DESV. SOT - DIR  
**200239** CREAM. MULTIP. MINIMALISTA  
NOVEM DESV. SOT - ESQ

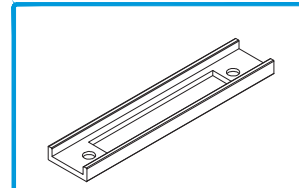

Material: Poliamida | Acabamento: Preto  
**218197** CALÇO P/ MULTIPONTO SOT JT

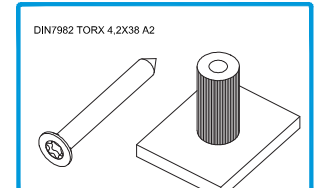

DIN7982 TORX 4.2X38 A2  
Para fixação das ferragens multiponto  
**212371** CONJ. FIXAÇÃO JT

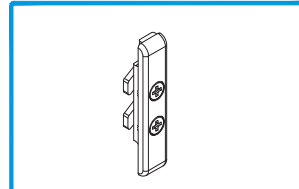

Material: Zamak | Acabamento: Prata  
**202492** CONTRA-FECHO SOT

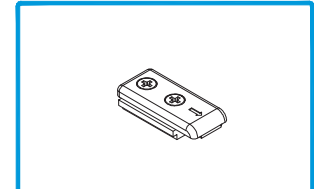

Aplicar nos perfis JT71 e JT72  
Material: Zamak | Acabamento: Prata  
**202320** CONTRA FECHO LIGAÇÃO  
2 FOLHAS E 90° SOT

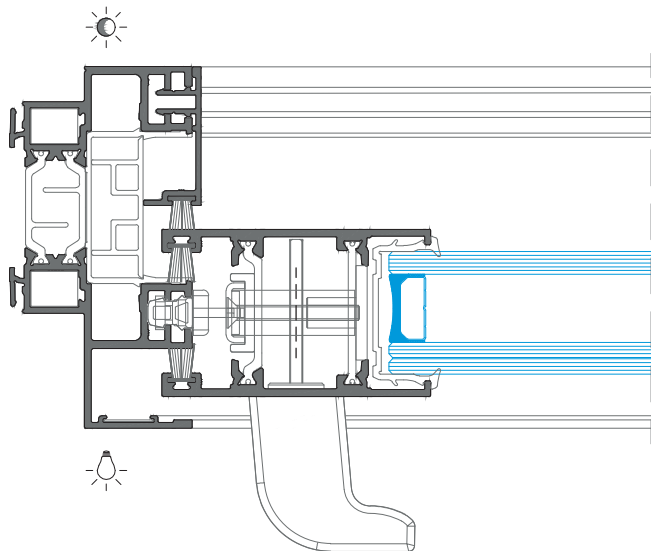

Estas peças devem ser coladas ao perfil móvel.  
These parts must be glued to the mobile profile.  
Ces pièces doivent être collées au profilé mobile.

**ESQUEMA FERRAGEM MULTIPONTO SEM CILINDRO**  
MULTIPOINT HARDWARE SCHEME WITHOUT CYLINDER  
SCHÉMA DE SERRURE MULTIPONTO SANS CYLINDRE

**ESQUEMA FERRAGEM MULTIPONTO COM CILINDRO**  
MULTIPOINT HARDWARE SCHEME WITH CYLINDER  
SCHÉMA DE SERRURE MULTIPONTO AVEC CYLINDRE

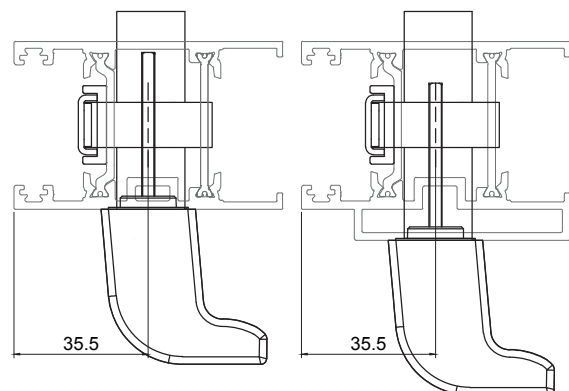
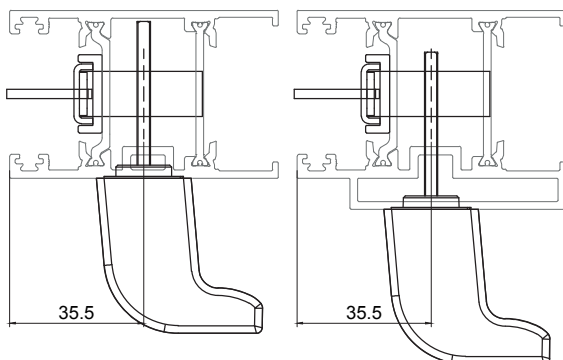

**MAQUINAÇÕES DOS PERFIS ARO MÓVEL JT**  
JT MOBILE FRAME PROFILES MACHINING  
USINAGE DES PROFILÉS OUVRANT JT

**19 - Ferragem Multiponto SOT.**  
SOT Multipoint Hardware.  
Serrure Multipoint SOT.

**19.2 - Medidas e maquinações.**  
Measures and milling.  
Mesures et usinages.

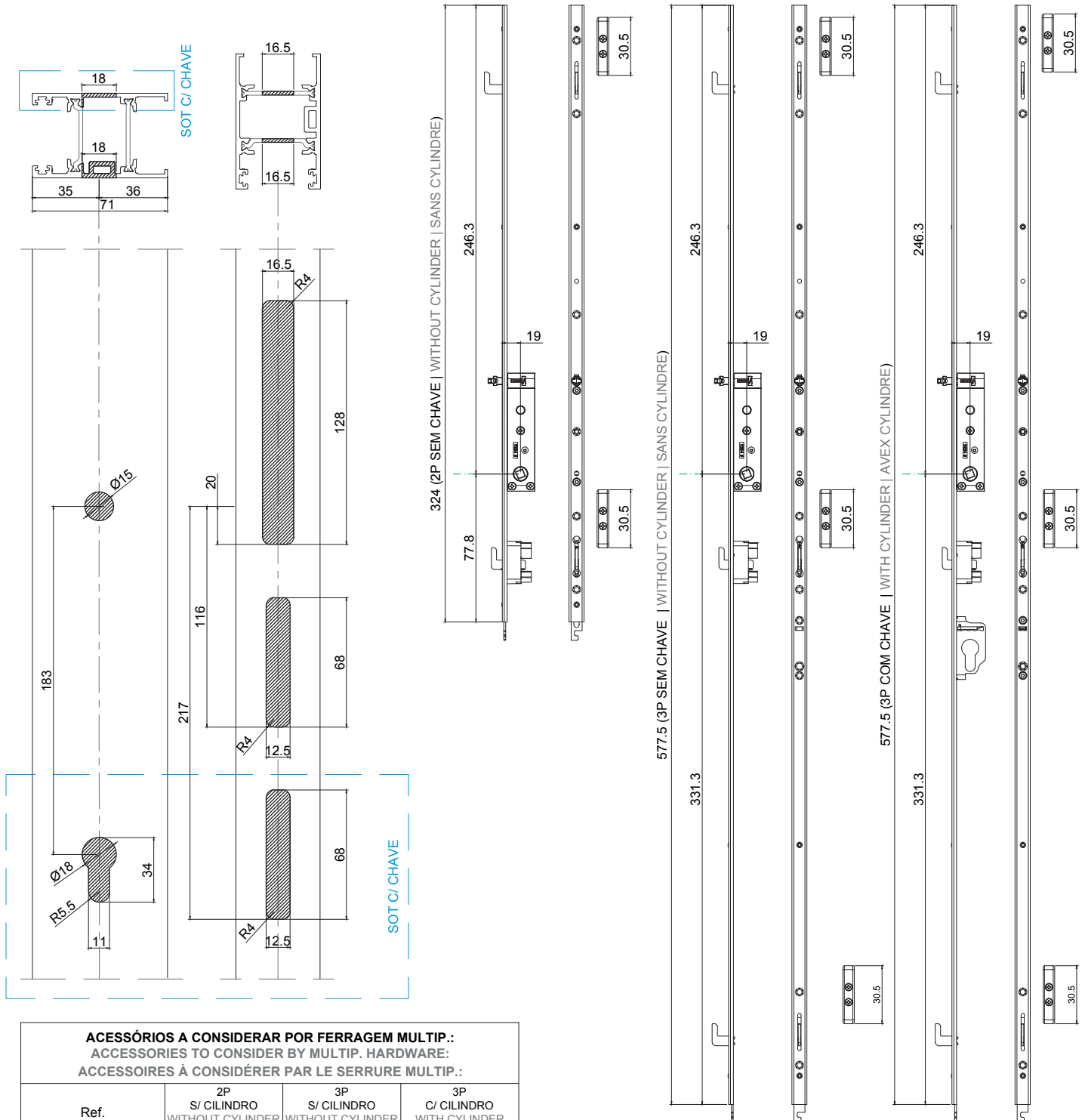

**ACESSÓRIOS A CONSIDERAR POR FERRAGEM MULTIP.:  
ACCESSORIES TO CONSIDER BY MULTIP. HARDWARE:  
ACCESSOIRES À CONSIDÉRER PAR LE SERRURE MULTIP.:**

Ref.	2P S/ CILINDRO WITHOUT CYLINDER SANS CYLINDRE	3P S/ CILINDRO WITHOUT CYLINDER SANS CYLINDRE	3P C/ CILINDRO WITH CYLINDER AVEC CYLINDRE
200238   200239	1	1	1
218197	3	5	5
212371	5	10	10
202492 <sup>(a)</sup> ou <sup>(b)</sup> ou 202320 <sup>(b)</sup>	2	3	3

- (a) Para tipologias de aro fixo.  
For fixed frame typologies.  
Pour les types de châssis fixes.
- (b) Para tipologias de encontro no mesmo rail e canto.  
For meeting on the same rail and corner typologies.  
Pour les typologies de réunion sur le même rail et d'angle.

\* Ver tabela da página "Aplicação do centrador"  
See table on page "Centering Part Application" | Voir tableau page "Application du Centreur"



## MAQUINAÇÕES DOS PERFIS ARO MÓVEL JT

JT MOBILE FRAME PROFILES MACHINING

USINAGE DES PROFILÉS OUVRANT JT

### 20 - Aplicação do centrador SOT.

SOT centering application.

Application de centrage SOT.

#### 20.1 - Janela de correr com fecho 1 ponto.

Sliding window with 1 locking point.

Fenêtre coulissant avec serrure 1 point.

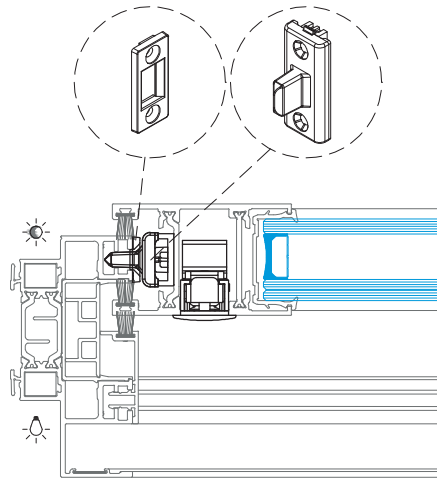
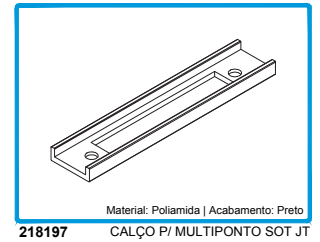
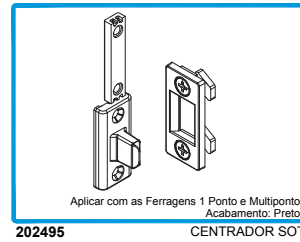
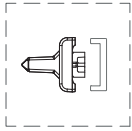

### SITUAÇÕES QUE CORRIGE CORRECTING SITUATIONS | CORRECTION DES SITUATIONS

- 1) Centralização de folhas desviadas até 6mm  
Centering of sheets deviated up to 6mm  
Centrage des feuilles déviées jusqu'à 6mm

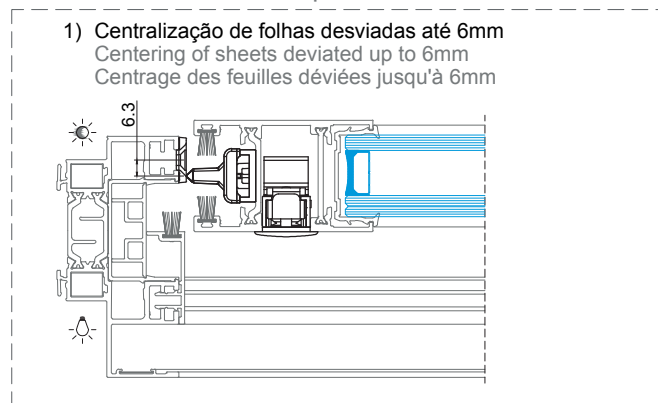

#### 20.2 - Janela de correr com fecho multipontos SOS e ALU.

Sliding window with SOS and ALU multipoint locking point.

Fenêtre coulissant avec serrure multipoint SOS et ALU.

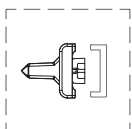

Aplicação de centrador fora do multiponto  
Applied outside multipoint  
Application aux extrémités du multipoint

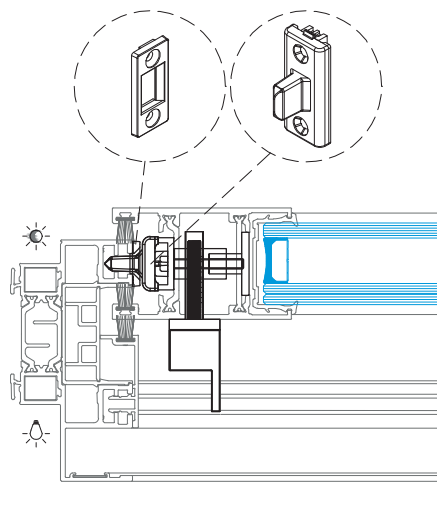
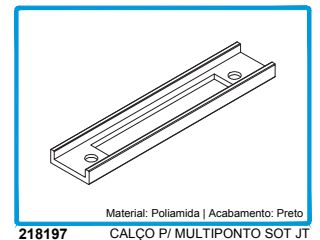
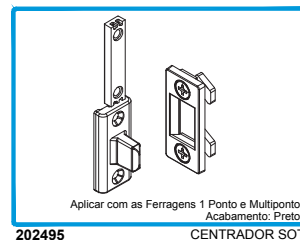

### SITUAÇÕES QUE CORRIGE CORRECTING SITUATIONS | CORRECTION DES SITUATIONS

- 1) Centralização de folhas desviadas até 6mm  
Centering of sheets deviated up to 6mm  
Centrage des feuilles déviées jusqu'à 6mm

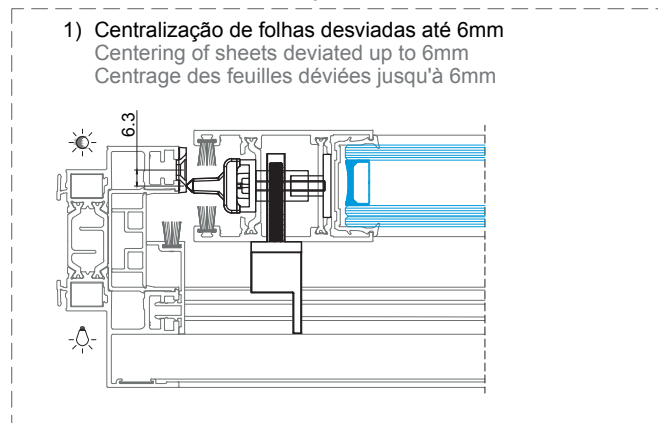

**MAQUINAÇÕES DOS PERFIS ARO MÓVEL JT**

JT MOBILE FRAME PROFILES MACHINING

USINAGE DES PROFILÉS OUVRANT JT

**20 - Aplicação do centrador SOT.**

SOT centering application.

Application de centrage SOT.

**20.3 - Janela de correr com fecho multipontos SOT.**

Sliding window with SOT multipoint locking point.

Fenêtre coulissant avec serrure multipoint SOT.

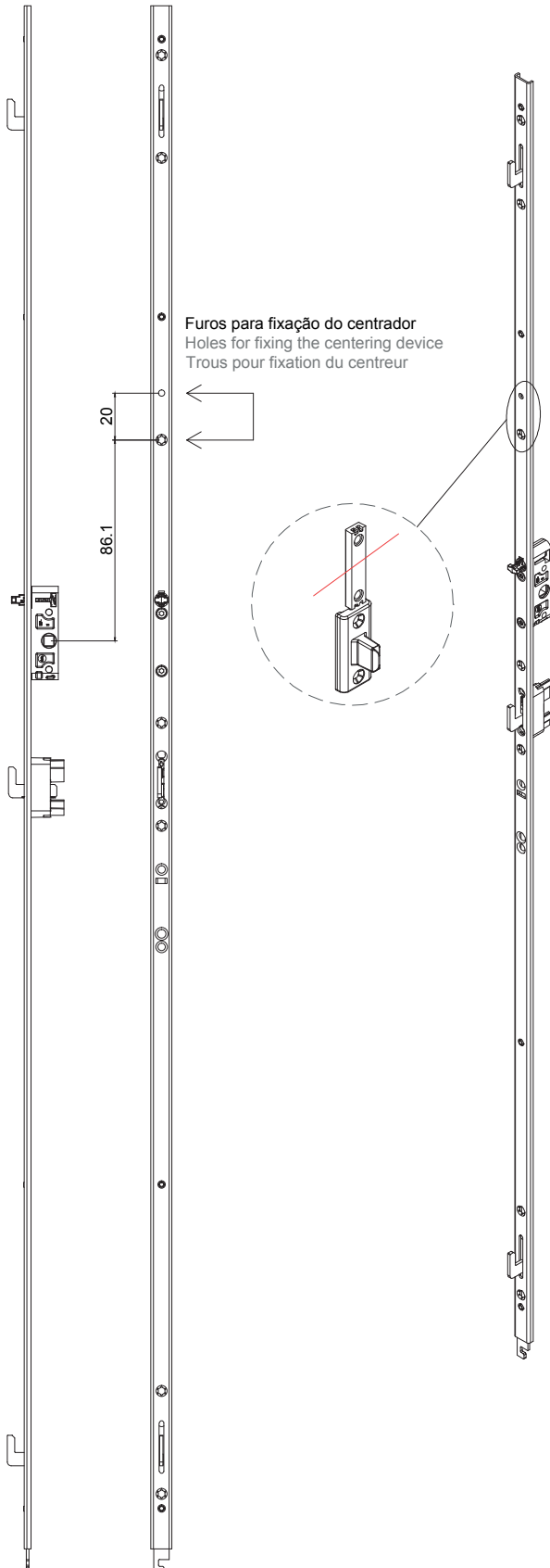

Furos para fixação do centrador  
Holes for fixing the centering device  
Trous pour fixation du centreur

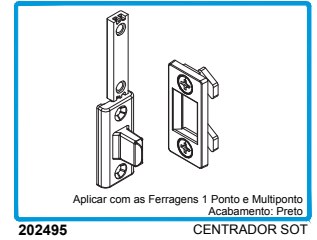
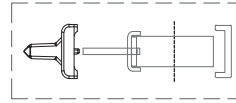

Na situação de 1 ponto de fecho, o centrador pode ser colocado em qualquer altura do perfil lateral.  
In 1 locking point situations, the centerer can be placed at any height of the lateral profile.  
Dans le cas de 1 point de fermeture, le centreur peut être placé à n'importe quelle hauteur du profilé latéral.

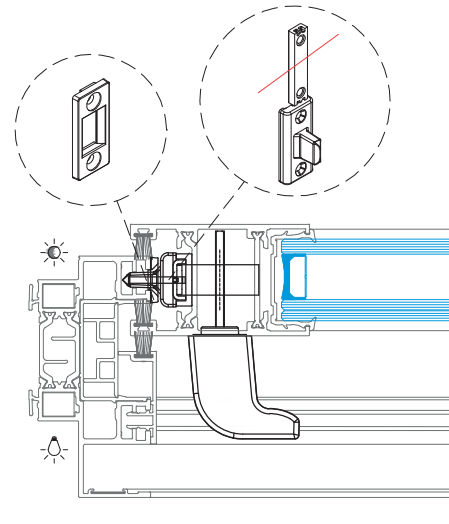

**SITUAÇÕES QUE CORRIGE  
CORRECTING SITUATIONS  
CORRECTION DES SITUATIONS**

- 1) Centralização de folhas desviadas até 6mm  
Centering of sheets deviated up to 6mm  
Centrage des feuilles déviées jusqu'à 6 mm

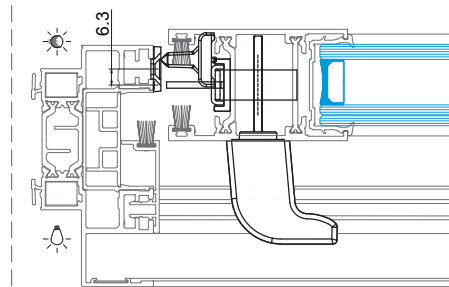

**MAQUINAÇÕES DOS PERFIS ARO MÓVEL JT**

JT MOBILE FRAME PROFILES MACHINING

USINAGE DES PROFILÉS OUVRANT JT

**20 - Aplicação do centrador SOT.**

SOT centering application.

Application de centrage SOT.

**20.4 - Número de centradores a aplicar.**

Number of concentrators to be applied.

Nombre de concentrateurs à appliquer.

	EXPOSIÇÃO 1 EXPOSURE 1   EXPOSITION 1		EXPOSIÇÃO 2 EXPOSURE 2   EXPOSITION 2	
	COR COLOR   COULEUR		COR COLOR   COULEUR	
ALTURA HIGH   HAUTEUR	CLARO BRIGHT   CLAIRE	ESCURO DARK   FONCÉE	CLARO BRIGHT   CLAIRE	ESCURO DARK   FONCÉE
H ≤ 1500	0	0	0	1
1500 < H ≤ 1750	0	1	1	2
1750 < H ≤ 2000	1	2	2	2
H > 2000	2	2	2	2

Exposição 1 = Norte, Noroeste, Nordeste  
Exposure 1 = North, North-West, North-East  
Exposition 1 = Nord, Nord-Ouest, Nord-Est

Exposição 2 = Sul, Sudeste, Sudoeste  
Exposure 2 = South, South-East, South-West  
Exposition 2 = Sud, Sud-Est, Sud-Ouest

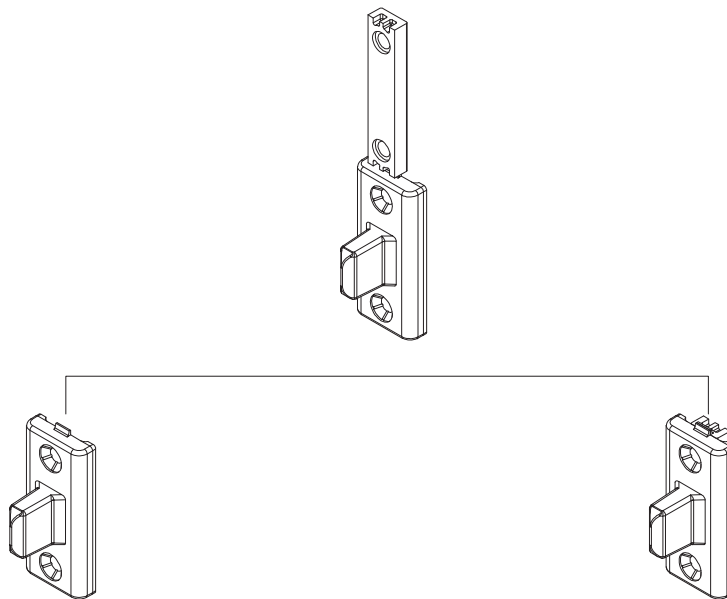

APLICAÇÃO FORA DAS FERRAGENS SOT  
APPLICATION OUTSIDE SOT HARDWARE  
APPLICATION HORS SERRURE SOT

APLICAÇÃO DIRETA NA FERRAGEM SOT  
DIRECT APPLICATION ON SOT HARDWARE  
APPLICATION DIRECTE SUR LE MATÉRIEL SOT

**MAQUINAÇÕES DOS PERFIS ARO MÓVEL JT**

JT MOBILE FRAME PROFILES MACHINING

USINAGE DES PROFILÉS OUVRANT JT

**21 - Medidas de corte do perfil de reforço JE 35.**

JT 35 reinforcement profile cutting measures.

Mesures de coupe du profilé de renfort JE 35.

PERFIS   PROFILES   PROFILÉS					
CÓDIGO CODE   COOE	DESIGNAÇÃO DESIGNATION   NOMINATION	CORTE VERT.   VERTICAL CUT   COUPE VERTICALE			CORTE CUT COUPE
		FR	PT	30mm	
JE 35	ARO FIXO FIXED FRAME   CADRE DORMANT	H-85	H-78	H-63	■
OS 30	PERFIL CENTRAL CENTRAL PROFILE   PROFILÉ CENTRAL	H-85	H-78	H-63	■
JT 61	PERFIL LATERAL LATERAL PROFILE   PROFILÉ LATÉRAL	H-81	H-74	H-59	■

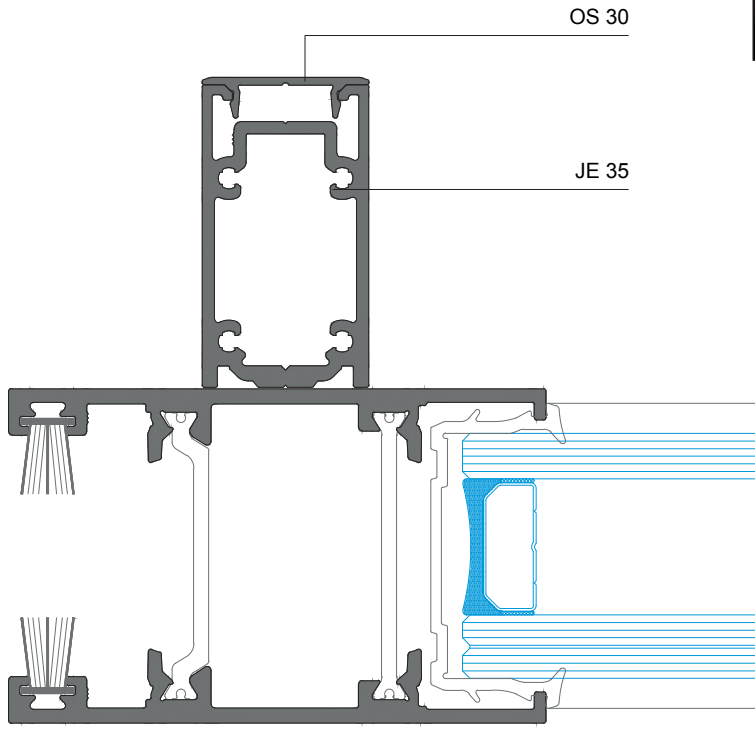

**22 - Maquinação do perfil de mosquiteira JT 47.**

JT 47 Mosquito net profile machining.

Usinage du profilé de mosquiteira JT 47.

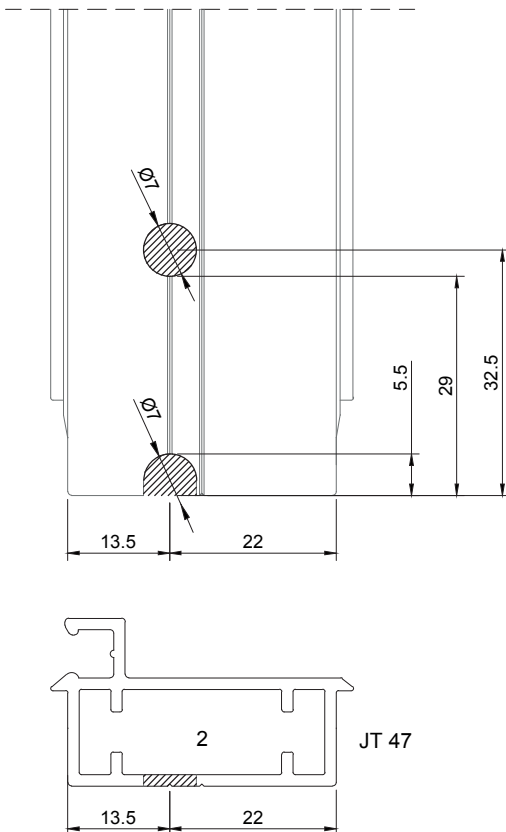

Maquinação realizada no Cortante  
Machining performed on Punching tool  
Usinage réalisée dans l'Outil

**2 - ESQUADRO | CORNER CLEAT | ÉQUERRE JT 11x20.5**

**MAQUINAÇÕES DOS PERFIS ARO MÓVEL JT**  
JT MOBILE FRAME PROFILES MACHINING  
USINAGE DES PROFILÉS OUVRANT JT

23 - Maquinação para Concha R2043i.  
R2043i Flush handle machining.  
Usinage pour Poignée cuvette R2043i.

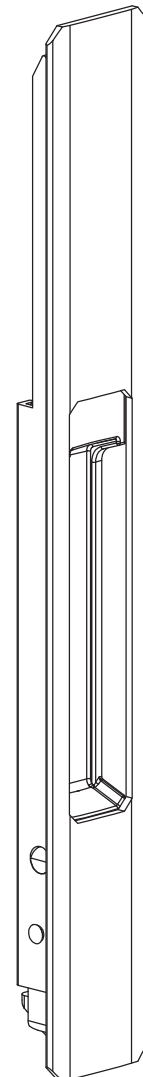
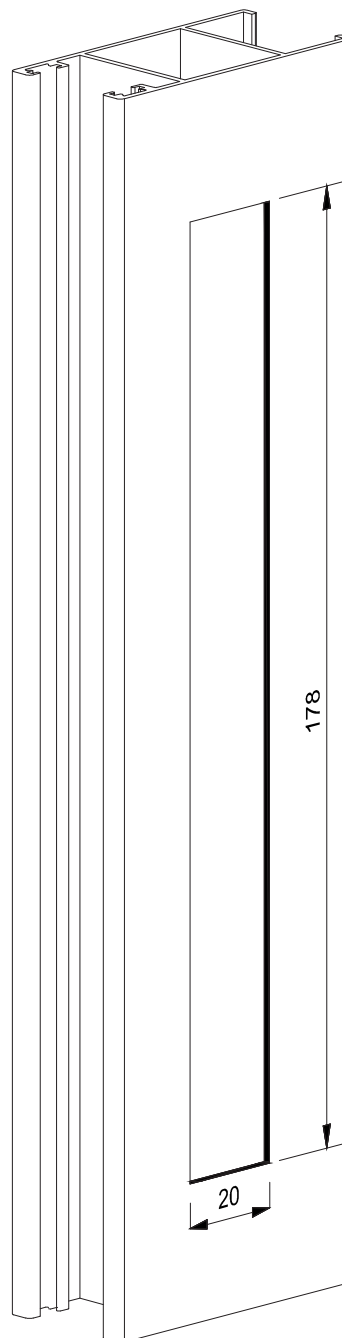
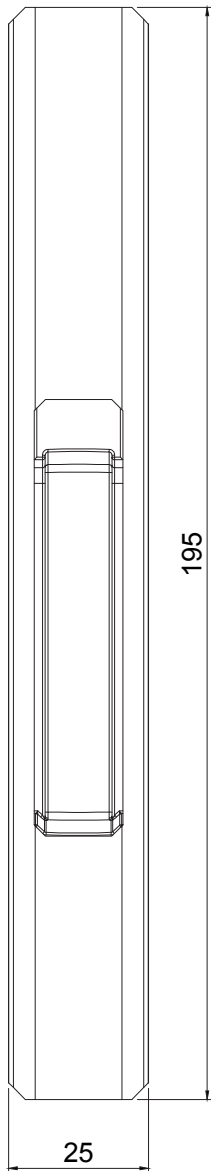
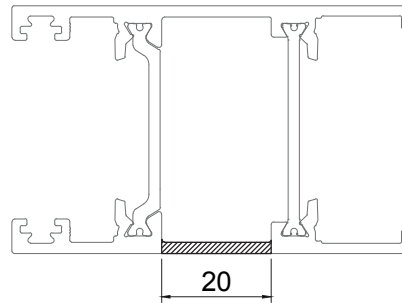
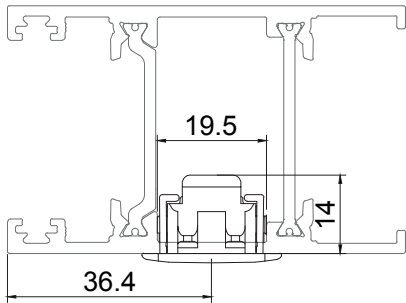

**MAQUINAÇÕES DOS PERFIS ARO MÓVEL JT-SLIM**

JT-SLIM MOBILE FRAME PROFILES MACHINING

USINAGE DES PROFILÉS OUVRANT JT-SLIM

**1 - Fresagem dos perfis laterais para colocação dos topos laterais inferiores e superiores.**

Lateral profiles milling for placing the lateral upper and lower end-caps.

Fraisage des profilés latéraux pour placer les embouts latéraux inférieurs et supérieurs.

Maquinação realizada no Cortante  
Machining performed on Punching tool  
Usinage réalisée dans l'Outil

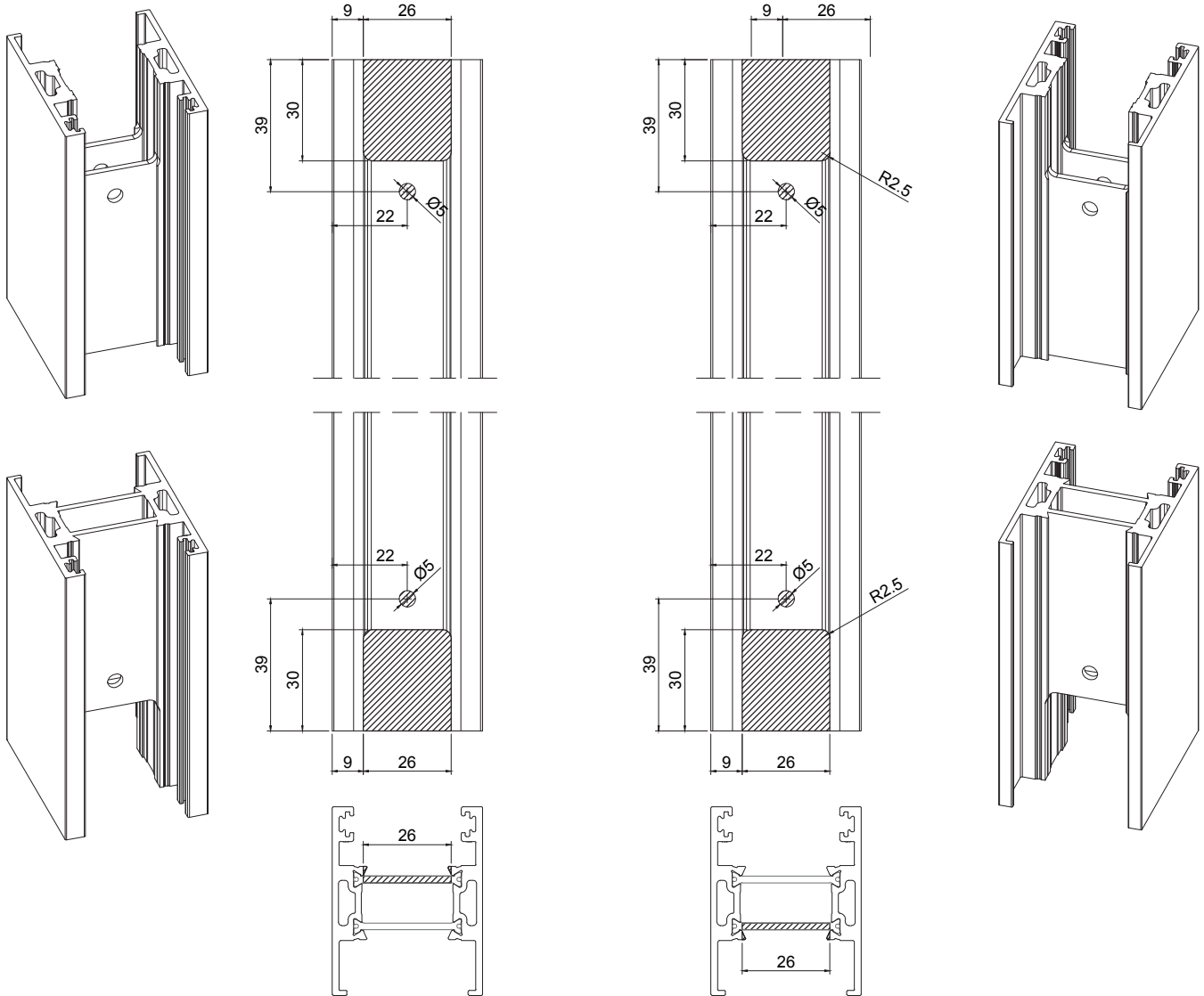

**JT 60**  
**Perfil Lateral**  
Lateral profile | Profilé latéral

**JT 60**  
**Perfil Lateral**  
Lateral profile | Profilé latéral

**JT 70**  
**Perfil lateral canto 90°**  
90° Corner lateral profile | Profilé latéral d'angle à 90°

**JT 70**  
**Perfil lateral canto 90°**  
90° Corner lateral profile | Profilé latéral d'angle à 90°

**MAQUINAÇÕES DOS PERFIS ARO MÓVEL JT-SLIM**

JT-SLIM MÓBILE FRAME PROFILES MACHINING

USINAGE DES PROFILÉS OUVRANT JT-SLIM

**2 - Fresagem dos perfis laterais para colocação das travessas superior e inferior.**

Lateral profiles milling for placing the upper and lower transoms.

Fraisage des profilés latéraux pour la mise en place des traverses supérieures et inférieures.

**Maquinação realizada no Cortante**  
Machining performed on Punching tool  
Usinage réalisée dans l'Outil

**JT 69**  
Travessa superior  
Upper transom | Traverse supérieur

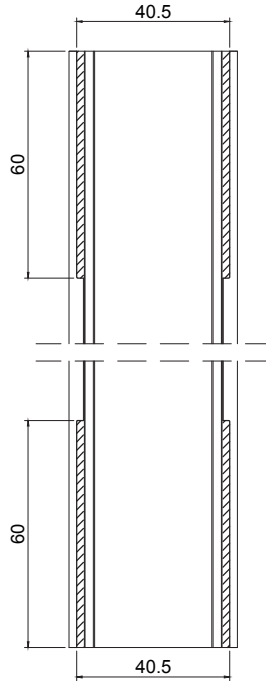
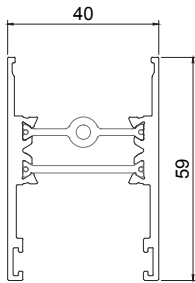
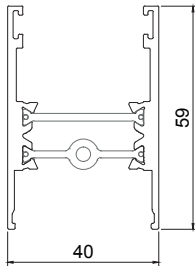

**É muito importante que esta maquinação seja feita depois da maquinação para os topos.**  
It is very important that this machining is done after the end-caps machining.  
Il est très important que cet usinage se fasse après l'usinage des embouts.

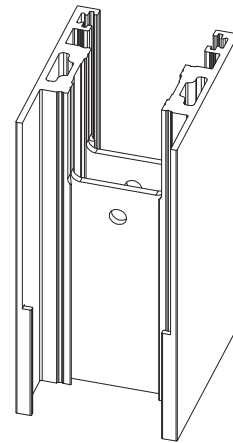

**JT 69**  
Travessa inferior  
Lower transom | Traverse inférieur

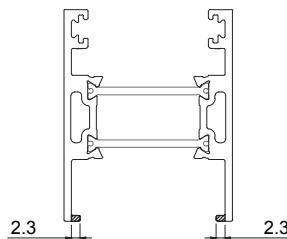

**JT 60**  
Perfil Lateral  
Lateral profile | Profilé latéral

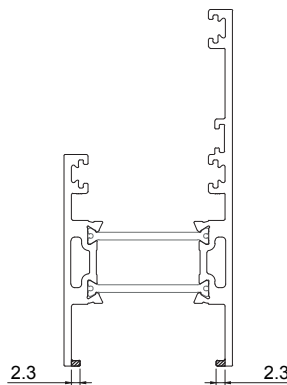
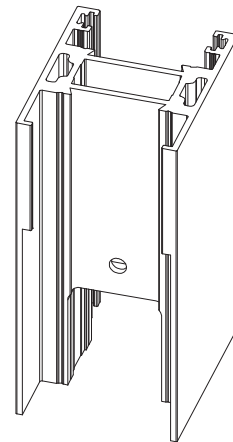

**JT 70**  
Perfil lateral canto 90°  
90° Corner lateral profile | Profilé latéral d'angle à 90°



**MAQUINAÇÕES DOS PERFIS ARO MÓVEL JT-SLIM**

JT-SLIM MOBILE FRAME PROFILES MACHINING

USINAGE DES PROFILÉS OUVRANT JT-SLIM

**3 - Fresagem de perfil central e junta central para colocação das travessas superior e inferior. Seguir este procedimento em todos os perfis centrais.**

Central profile and joint milling for placing the upper and lower transoms.

**Follow this procedure in all central profiles.**

Fraisage du profilé central et du joint central pour la mise en place des traverses supérieure et inférieure. **Suivre cette procédure sur tous les profilés centraux.**

Maquinação realizada no Cortante  
Machining performed on Punching tool  
Usinage réalisée dans l'Outil

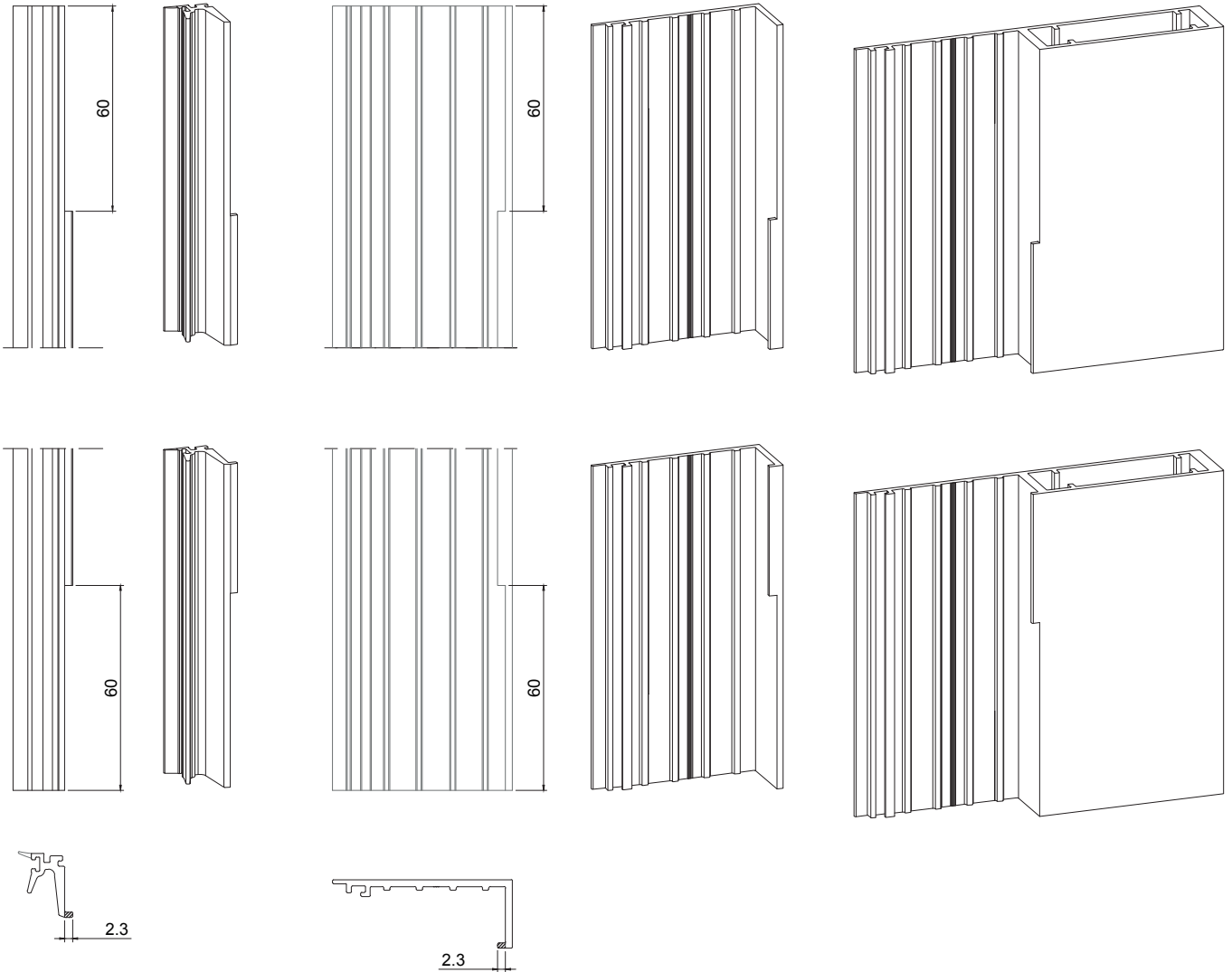

**JUNTA CENTRAL 2197 JT-SLIM**  
2197 JT-SLIM CENTRAL JOINT  
JOINT CENTRALE 2197 JT-SLIM

**JT 55**  
Perfil central  
Central profile | Profilé central

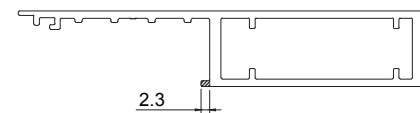

**JT 56**  
Perfil central reforçado  
Reinforced central profile | Profilé central renforcé

**MAQUINAÇÕES DOS PERFIS ARO MÓVEL JT-SLIM**

JT-SLIM MÓBILE FRAME PROFILES MACHINING

USINAGE DES PROFILÉS OUVRANT JT-SLIM

4 - Fresagem do perfil central para colocação dos topos centrais superiores e inferiores.

Maquinação realizada no Cortante  
Machining performed on Punching tool  
Usinage réalisée dans l'Outil

**Seguir este procedimento em todos os perfis centrais.**

Central profile milling for placing the central upper and lower end-caps.

**Follow this procedure in all central profiles.**

Fraisage du profilé central pour la mise en place des plateaux centraux supérieur et inférieur.

**Suivre cette procédure sur tous les profilés centraux.**

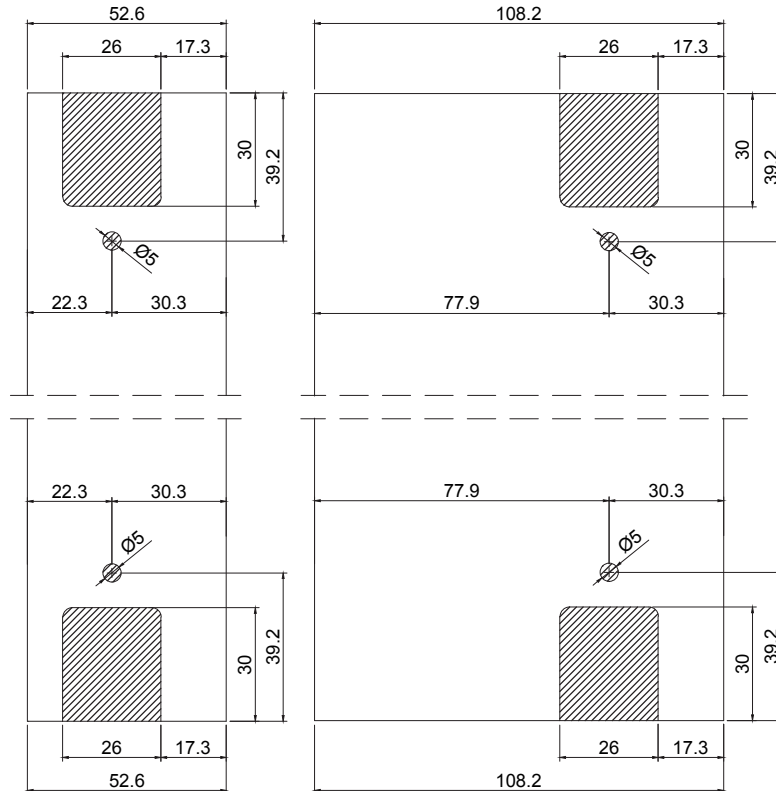

**JT 55**  
Perfil central  
Central profile | Profilé central

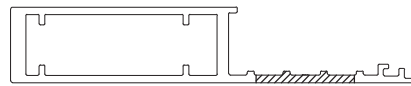

**JT 56**  
Perfil central reforçado  
Reinforced central profile | Profilé central renforcé

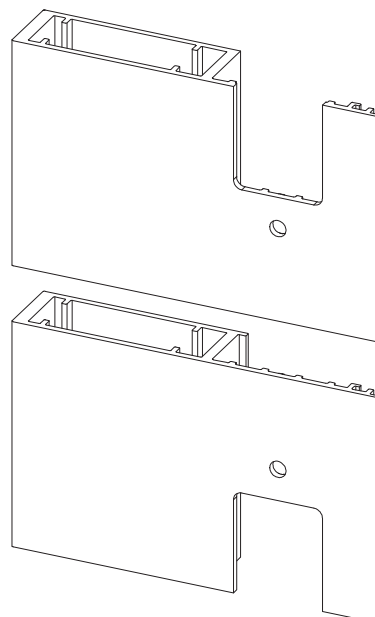
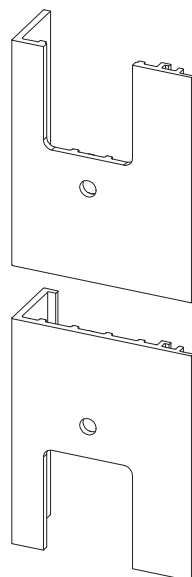

## MAQUINAÇÕES DOS PERFIS ARO MÓVEL JT-SLIM

JT-SLIM MOBILE FRAME PROFILES MACHINING

USINAGE DES PROFILÉS OUVRANT JT-SLIM

5 - Fresagem dos perfis centrais de reforço.

**Seguir este procedimento em todos os perfis centrais.**

Reinforcement central profile milling.

**Follow this procedure in all central profiles.**

Fraisage des profilés de renfort centraux.

**Suivre cette procédure sur tous les profilés centraux.**

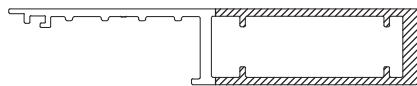
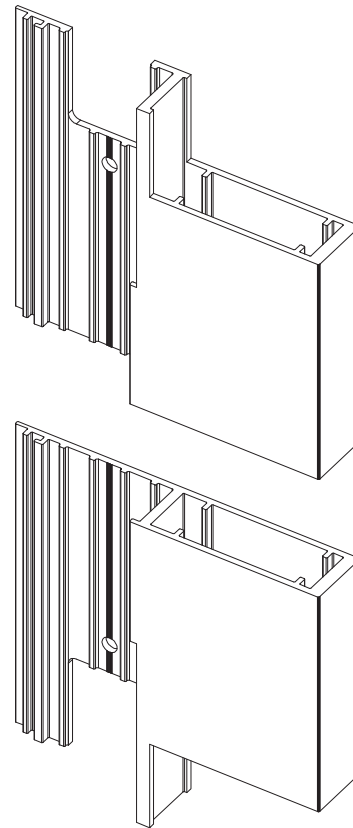
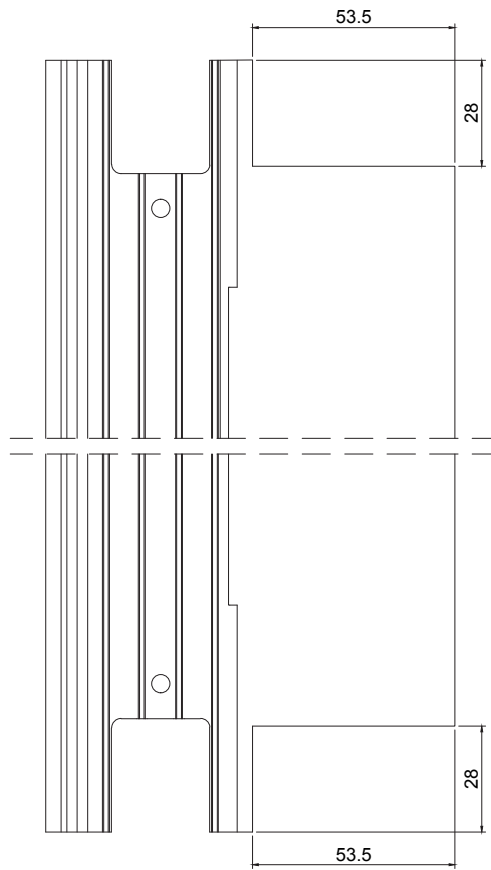

**JT 56**  
Perfil central reforçado  
Reinforced central profile | Profilé central renforcé

**MAQUINAÇÕES DOS PERFIS ARO MÓVEL JT-SLIM**

JT-SLIM MOBILE FRAME PROFILES MACHINING

USINAGE DES PROFILÉS OUVRANT JT-SLIM

**6 - Aplicação do limitador de abertura na travessa inferior JT 69.**

Opening limiter application on the lower transom JT 69.

Application du limiteur d'ouverture sur la traverse inférieure JT 69.

**6.1 - Furação para a fixação do limitador de abertura.**

Drilling for fixing the opening limiter.

Perçage pour fixation du limiteur d'ouverture.

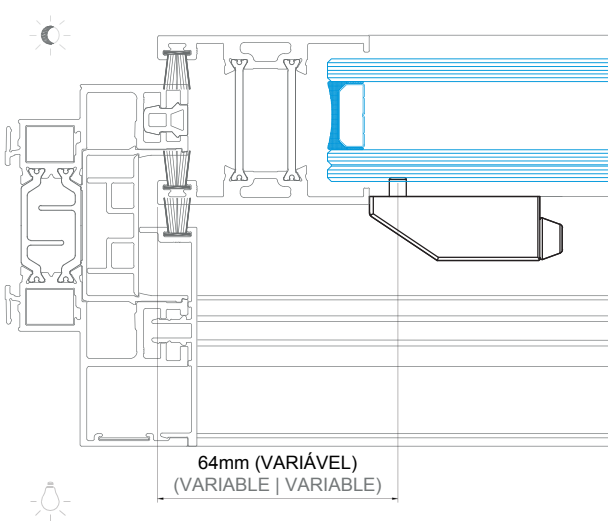
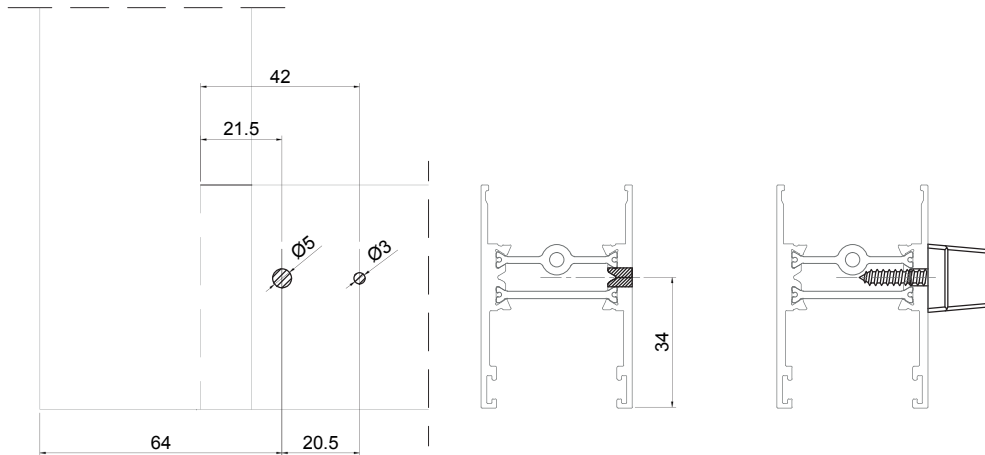
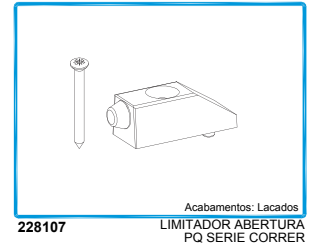

**Medida variável mediante cremone a aplicar.**

Variable measure by means of handle to be applied.

Mesure variable utilisant la crémonne à appliquer.

**6.2 - Aparafusar o limitador de abertura à travessa.**

Screw the opening limiter to the transom.

Visser le limiteur d'ouverture sur la traverse.

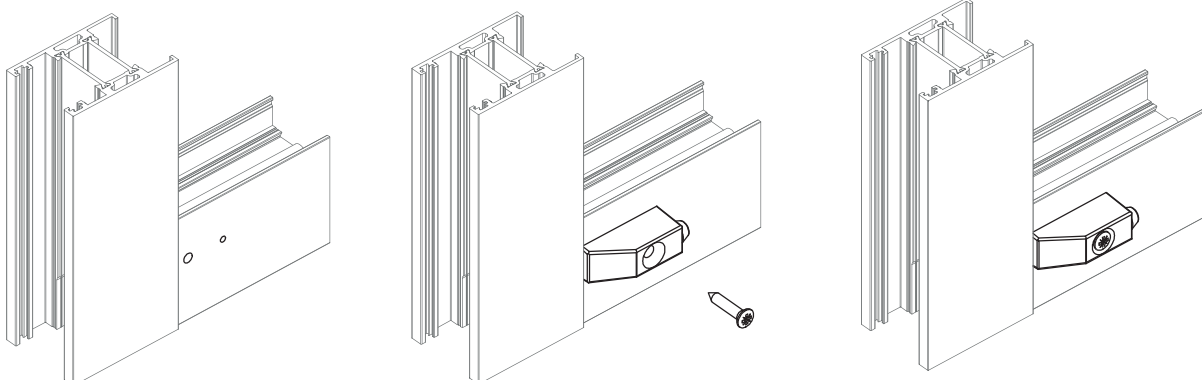

## MAQUINAÇÕES DOS PERFIS ARO MÓVEL JT-SLIM

JT-SLIM MOBILE FRAME PROFILES MACHINING

USINAGE DES PROFILÉS OUVRANT JT-SLIM

### 7 - Furação para drenagens e decompressão e aplicação dos carrinhos.

Drainage and decompression drilling and rollers application.

Perçage pour drainage et décompression et application des roulettes.

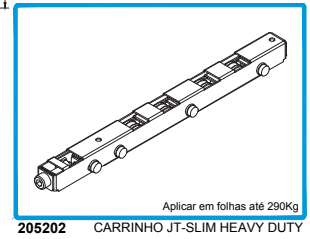
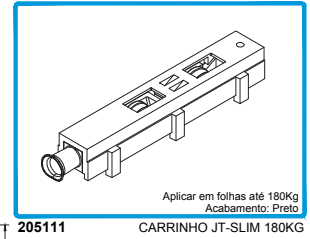
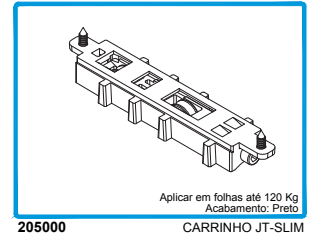
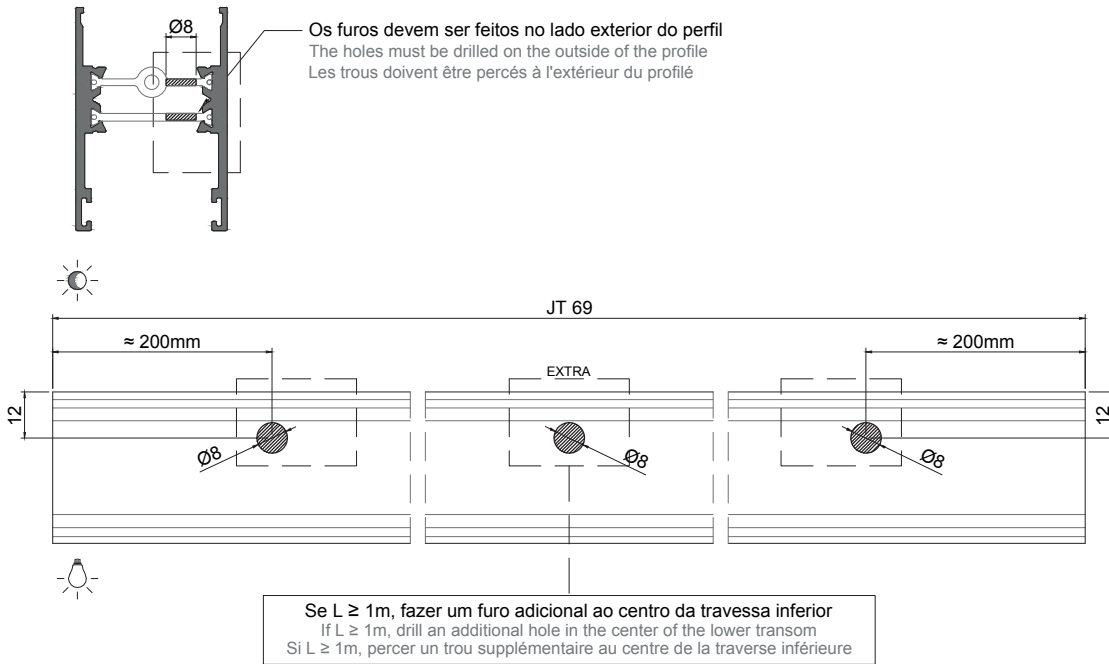

### 8 - Maquinação para aplicação de Carrinhos JT-Slim.

Machining for application of the JT-Slim rollers.

Usinage pour application de Roulettes JT-Slim.

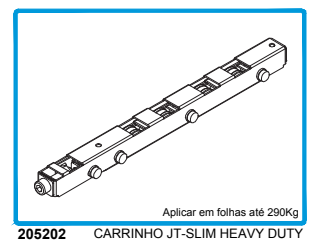
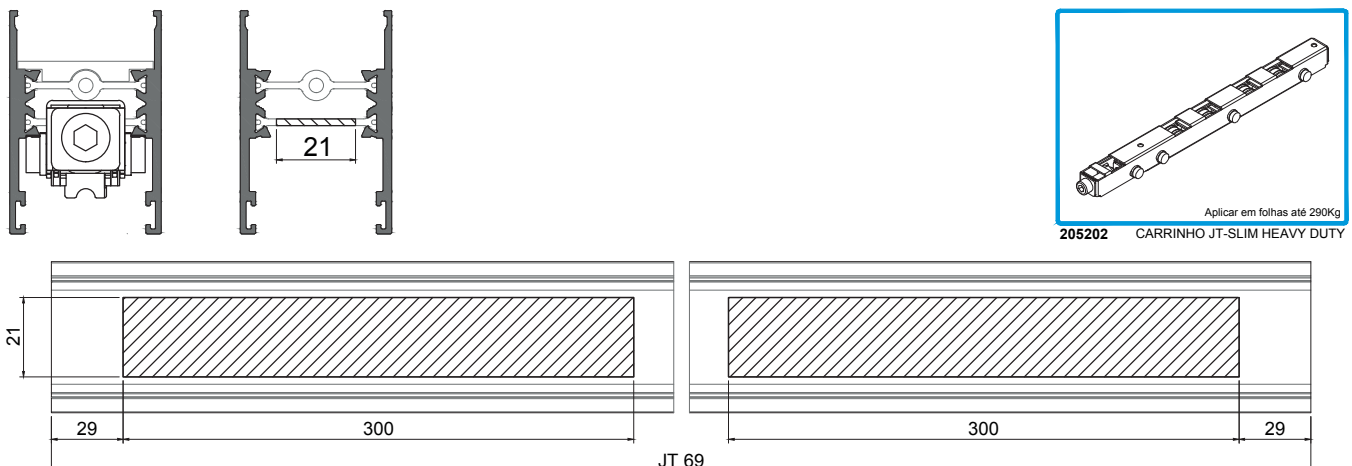
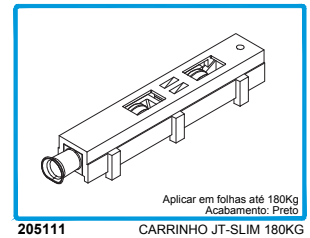
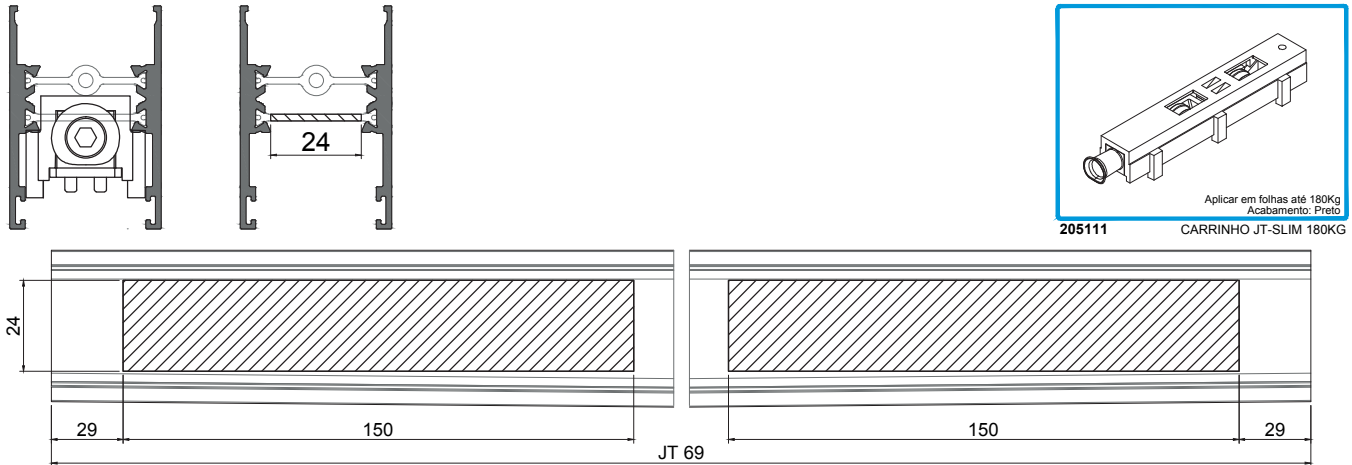

**MAQUINAÇÕES DOS PERFIS ARO MÓVEL JT-SLIM**

JT-SLIM MOBILE FRAME PROFILES MACHINING

USINAGE DES PROFILÉS OUVRANT JT-SLIM

**9 - Ferragens 1 Ponto e Multiponto.**

1 Point and Multipoint Hardwares.

Serrures 1 Point and Multipoint.

**9.1 - Altura do furo do cremone no perfil lateral, com aro fixo FR.**

Handle's hole height in the side profile, with FR fixed frame.

Hauteur du trou de crémonne dans le profilé latéral, avec dormant FR.

**Hcrem, pl = Hcrem, solo - 40mm**  
**Hhandle, lp = Hhandle, ground - 40mm**  
**Hcrem, pl = Hcrem, sol - 40mm**

**Exemplo | Example | Exemple:**

Para colocação do mecanismo de fecho a 1000mm relativamente ao solo, o centro da maquinação deverá ser feito no perfil lateral a uma altura de 1000-40=960mm.

For placing the closing mechanism at 1000mm in relation to the ground, the machining center should be made in the lateral profile at a height of 1000-40=960mm.

Pour placer le mécanisme de fermeture à 1000mm par rapport au sol, le centre d'usinage doit être réalisé dans le profilé latéral à une hauteur de 1000-40=960mm.

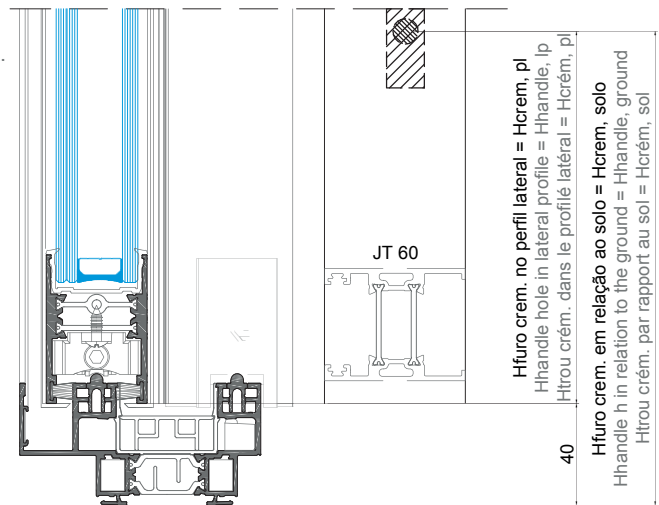

**9.2 - Altura do furo do cremone no perfil lateral, com aro fixo PT.**

Handle's hole height in the side profile, with PT fixed frame.

Hauteur du trou de crémonne dans le profilé latéral, avec dormant PT.

**Hcrem, pl = Hcrem, solo - 37mm**  
**Hhandle, lp = Hhandle, ground - 37mm**  
**Hcrem, pl = Hcrem, sol - 37mm**

**Exemplo | Example | Exemple:**

Para colocação do mecanismo de fecho a 1000mm relativamente ao solo, o centro da maquinação deverá ser feito no perfil lateral a uma altura de 1000-37=963mm.

For placing the closing mechanism at 1000mm in relation to the ground, the machining center should be made in the lateral profile at a height of 1000-37=963mm.

Pour placer le mécanisme de fermeture à 1000mm par rapport au sol, le centre d'usinage doit être réalisé dans le profilé latéral à une hauteur de 1000-37=963mm.

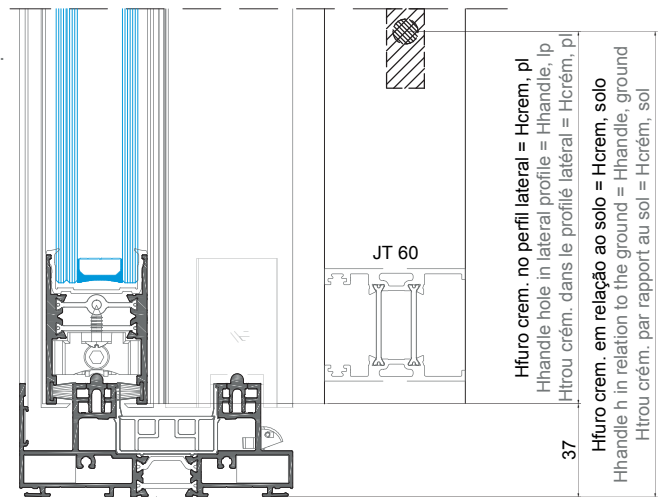

**9.3 - Altura do furo do cremone no perfil lateral, com soleira 30mm.**

Handle's hole height in the side profile, with 30mm sill.

Hauteur du trou de crémonne dans le profilé latéral, avec seuil 30mm.

**Hcrem, pl = Hcrem, solo - 22mm**  
**Hhandle, lp = Hhandle, ground - 22mm**  
**Hcrem, pl = Hcrem, sol - 22mm**

**Exemplo | Example | Exemple:**

Para colocação do mecanismo de fecho a 1000mm relativamente ao solo, o centro da maquinação deverá ser feito no perfil lateral a uma altura de 1000-22=978mm.

For placing the closing mechanism at 1000mm in relation to the ground, the machining center should be made in the lateral profile at a height of 1000-22=978mm.

Pour placer le mécanisme de fermeture à 1000mm par rapport au sol, le centre d'usinage doit être réalisé dans le profilé latéral à une hauteur de 1000-22=978mm.

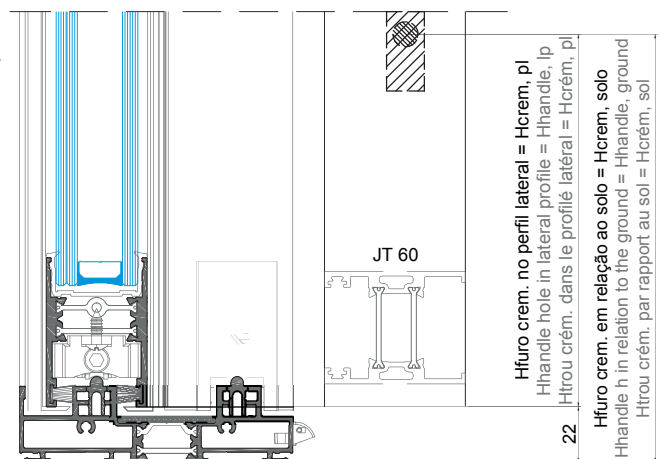

**MAQUINAÇÕES DOS PERFIS ARO MÓVEL JT-SLIM**

JT-SLIM MOBILE FRAME PROFILES MACHINING

USINAGE DES PROFILÉS OUVRANT JT-SLIM

**10 - Ferragens Multiponto MAC ALU.**

ALU MAC and Multipoint Hardwares.  
Serrures Multipoint MAC ALU.

**10.1 - Esquema de aplicação.**

Application scheme.  
Schéma d'application.

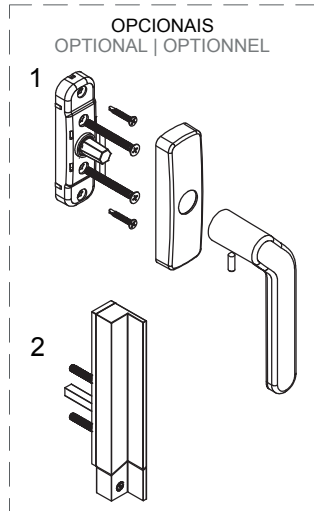
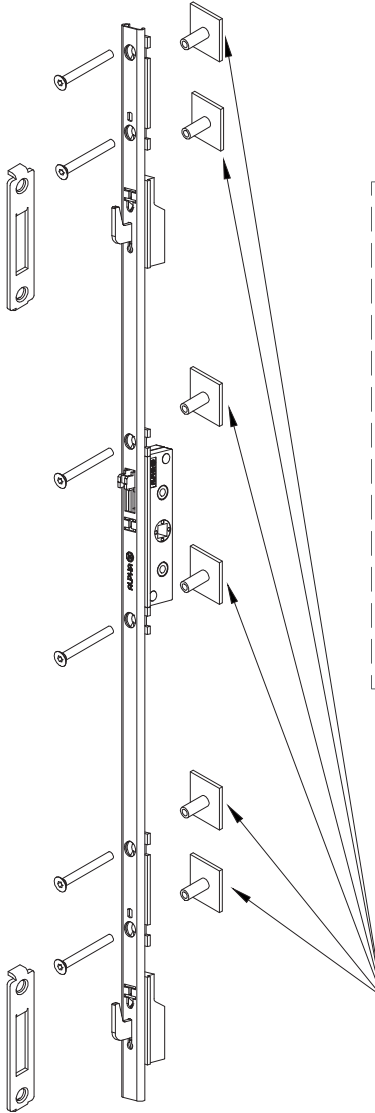

Estas peças devem ser coladas ao perfil móvel.  
These parts must be glued to the mobile profile.  
Ces pièces doivent être collées au profilé mobile.

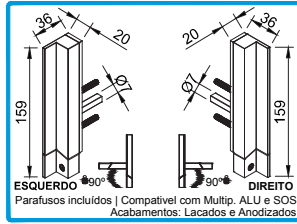
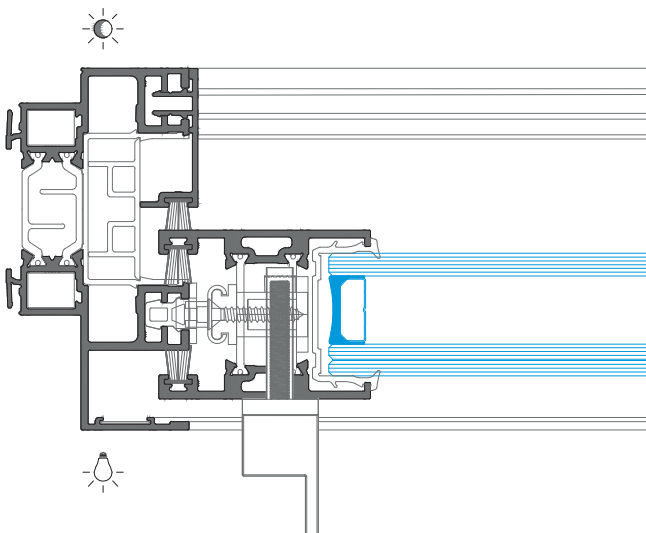

**200817** PUXADOR SLIM XS (Direito)  
**200819** PUXADOR SLIM XS (Esquerdo)  
Parafusos incluídos | Compatível com Multip. ALU e SOS  
Acabamentos: Lacados e Anodizados

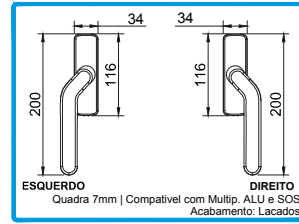

**200959** CREMONE MULT. DESVIADO DIR  
**200939** CREMONE MULT. DESVIADO ESQ  
Quadra 7mm | Compatível com Multip. ALU e SOS  
Acabamento: Lacados

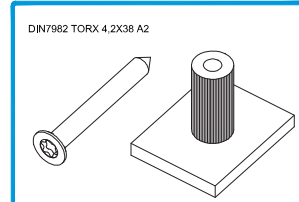

**212371** CONJ. FIXAÇÃO JT  
Para fixação das ferragens multiponto

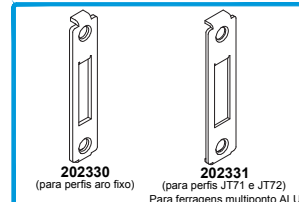

**202330** (para perfis aro fixo) **202331** (para perfis JT71 e JT72)  
Para ferragens multiponto ALU  
Material: Inox | Acabamento: Inox  
**202330** **202331** CONTRA-FECHO ALU  
CONTRA-FECHO Nº2 2F/90º ALU

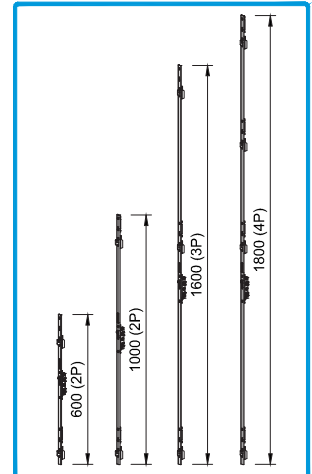

Material: Inox | Acabamento: Inox  
**211233** MULTIPONTO ALU MAC.600 (2P)  
**211234** MULTIPONTO ALU MAC.1000 (2P)  
**211235** MULTIPONTO ALU MAC.1600 (3P)  
**211236** MULTIPONTO ALU MAC.1800 (4P)

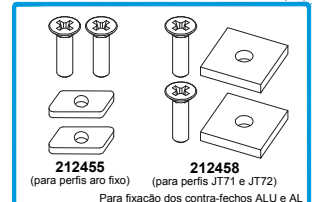

Para fixação dos contra-fechos ALU e AL  
Acabamentos: Inox (ref. 212455/58) e Preto (ref. 212455)  
**212455** (para perfis aro fixo) **212458** (para perfis JT71 e JT72)  
Para fixação dos contra-fechos ALU e AL  
Acabamentos: Inox (ref. 212455/58) e Preto (ref. 212455)  
**212455** **212458** CONJ. FIX. C.-FECHO AL MULTIP. JT  
CONJ. FIX. C.-FECHO 2F/90º JT

**CREMONE MULTIPONTO DESVIADO**  
DEVIATED MULTIPOINT HANDLE | CRÉMONE MULTIPOINT DÉVIÉ

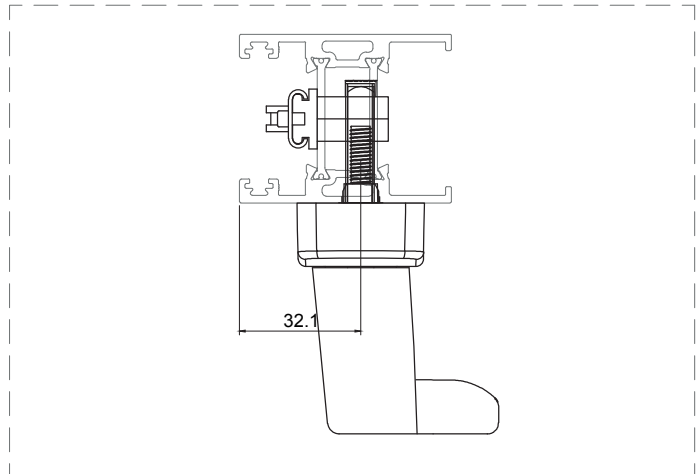

**PUXADOR SLIM XS**  
XS SLIM HANDLE | POIGNÉE SLIM XS

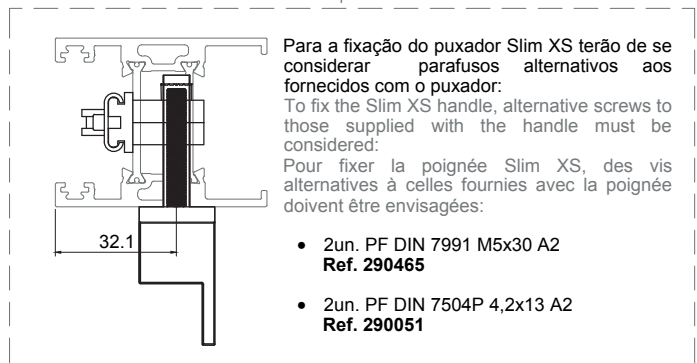





# VI

## MONTAGEM DOS PERFIS PROFILES ASSEMBLY | ASSEMBLAGE DES PROFILÉS

MONTAGEM DOS PERFIS ARO FIXO FR E PT (CORTE 45°) FR AND PT FIXED FRAME PROFILES ASSEMBLY (45° CUT) ASSEMBLAGE DES PROFILÉS DORMANT FR ET PT (COUPE 45°)	VI.1
MONTAGEM DOS PERFIS ARO FIXO PARA TIPOLOGIAS FIXAS (CORTE 45°) FIXED TYPOLOGIES FIXED FRAME PROFILES ASSEMBLY (45° CUT) ASSEMBLAGE DES PROFILÉS DORMANT POUR TYPOLOGIES FIXES (COUPE 45°)	VI.2
MONTAGEM DOS PERFIS ARO FIXO COM SOLEIRA 30MM (CORTE 90°) FIXED FRAME PROFILES ASSEMBLY WITH 30MM SILL PROFILE (90° CUT) ASSEMBLAGE DES PROFILÉS DORMANT AVEC SEUIL 30MM (COUPE 90°)	VI.3
MONTAGEM DOS PERFIS ARO FIXO PT (CORTE 45°) COM SOLEIRA 30MM (CORTE 90°) PT FIXED FRAME PROFILES ASSEMBLY (45° CUT) WITH 30MM SILL PROFILE (90° CUT) ASSEMBLAGE DES PROFILÉS DORMANT PT (COUPE 45°) AVEC SEUIL 30MM (COUPE 90°)	VI.4
MONTAGEM DE TIPOLOGIAS DE EMBUTIR HIDDEN SLIDING TYPOLOGIES ASSEMBLY ASSEMBLAGE DE TYPOLOGIES À GALANDAGE	VI.5
MONTAGEM DOS PERFIS ARO MÓVEL JT JT MOBILE FRAME PROFILES ASSEMBLY ASSEMBLAGE DES PROFILÉS OUVRANT JT	VI.6
MONTAGEM DOS PERFIS ARO MÓVEL JT-SLIM JT-SLIM MOBILE FRAME PROFILES ASSEMBLY ASSEMBLAGE DES PROFILÉS OUVRANT JT-SLIM	VI.7
MONTAGEM DE PERFIS DE CAPA COVER PROFILES ASSEMBLY ASSEMBLAGE DES PROFILÉS DE CAPOT	VI.8
MONTAGEM DO PERFIL DE REFOÇO/PUXADOR JE 35 + TAMPA OS 30 REINFORCEMENT PROFILE/HANDLE JE 35 + COVER OS 30 ASSEMBLY ASSEMBLAGE PROFILÉ DE RENFORCEMENT/POIGNÉE JE 35 + CAPOT OS 30	VI.9

**MONTAGEM DOS PERFIS ARO FIXO FR E PT (CORTE 45°)**  
FR E PT FIXED FRAME PROFILES ASSEMBLY (45° CUT)  
ASSEMBLAGE DES PROFILÉS DORMANT FR ET PT (COUPE 45°)

1 - Colocação do conjunto de estanqueidade para corta-vento nos aros fixos.  
Central waterproofing pile seal kit placing in fixed frames.  
Mise en place du kit brosse centrale d'étanchéité pour les cadres dormants.

1.1 - Colocar o Conjunto de estanqueidade, apenas em baixo, no cruzamento das folhas onde posteriormente levará o perfil PVC U e os corta-ventos. **Seguir este procedimento em todos os perfis de aro fixo FR e PT.**  
Place the central waterproofing pile seal kit, only on the bottom, at the intersection of the sashes where later the U PVC profile and the central gasket will be. **Follow this procedure in all fixed frame profiles FR and PT.**  
Placer le kit brosse centrale d'étanchéité à l'intersection des vantaux, juste en bas, où prendront plus tard le profilé PVC U et les brosses centrales d'étanchéité. **Suivre cette procédure sur tous les profilés dormant FR et PT.**

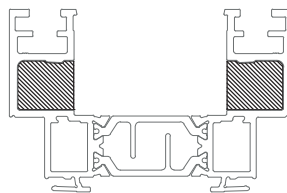
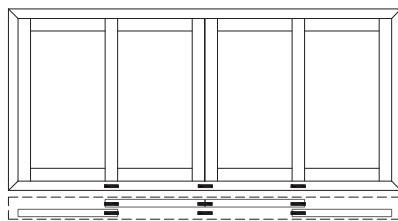
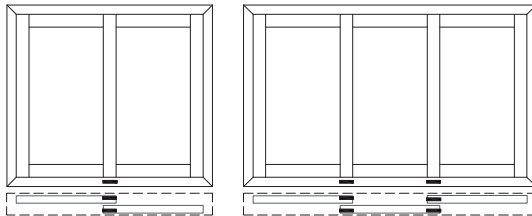
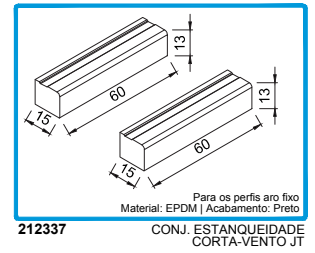

JT 01

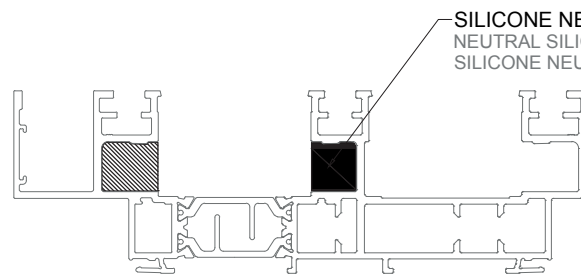

SILICONE NEUTRO  
NEUTRAL SILICONE  
SILICONE NEUTRE

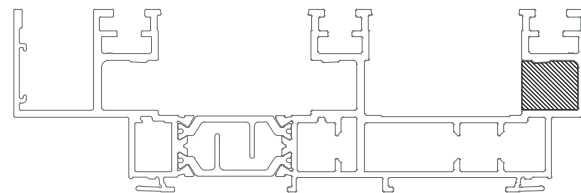

JT 03

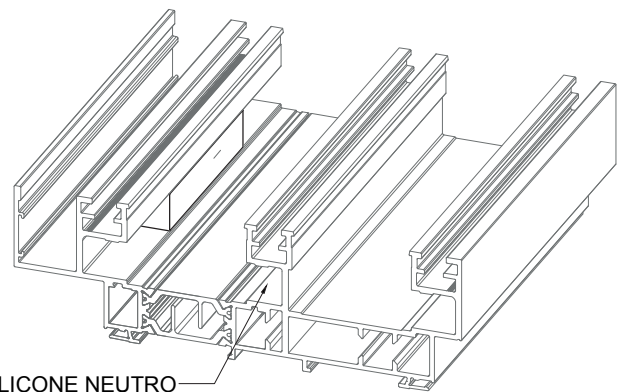
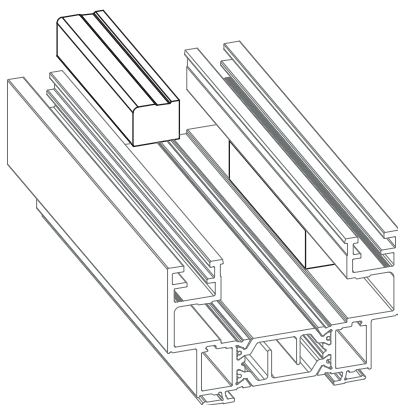

SILICONE NEUTRO  
NEUTRAL SILICONE  
SILICONE NEUTRE

1º Conj. estanqueidade (em baixo) Waterproofing kit (on the bottom) Kit d'étanchéité (en bas)	
2º Perfil PVC U PVC U Profile Profilé PVC U	
3º Corta-vento Central waterproofing pile seal Brosse centrale d'étanchéité	

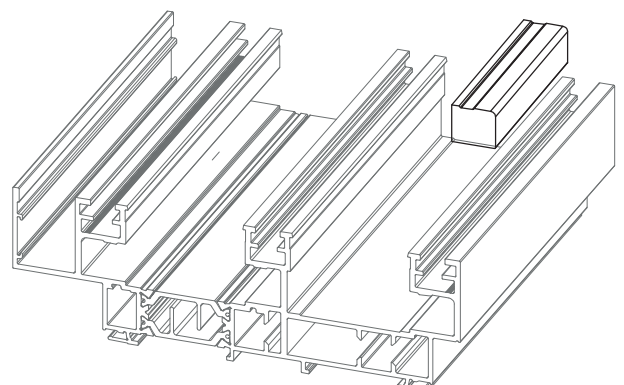

**MONTAGEM DOS PERFIS ARO FIXO FR E PT (CORTE 45°)**  
FR E PT FIXED FRAME PROFILES ASSEMBLY (45° CUT)  
ASSEMBLAGE DES PROFILÉS DORMANT FR ET PT (COUPE 45°)

**2 - Colocação de goteiras nos aros fixos.**

Drips placing in fixed frames.

Placement des clapets sur les cadres dormants.

**2.1 - Colocar as goteiras ocultas antes do perfil PVC U e fixá-las com pontos de silicone nas extremidades. Seguir este procedimento em todos os perfis de aro fixo FR.**

Place the hidden drips before the U PVC profile and fix them with silicone points at the edges. Follow this procedure in all FR fixed frame profiles.

Placer les clapets à volet cachées avant le profilé PVC U et fixer-les avec des points de silicone aux extrémités. Suivre cette procédure sur tous les profilés dormant FR.

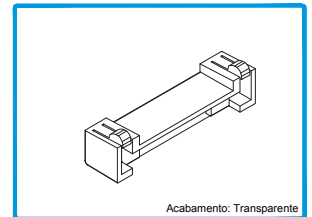

Acabamento: Transparente  
**210269** GOTEIRA OCULTA C/ VÁLV. SV-C13

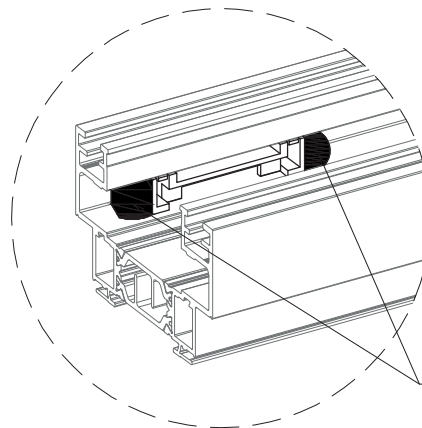
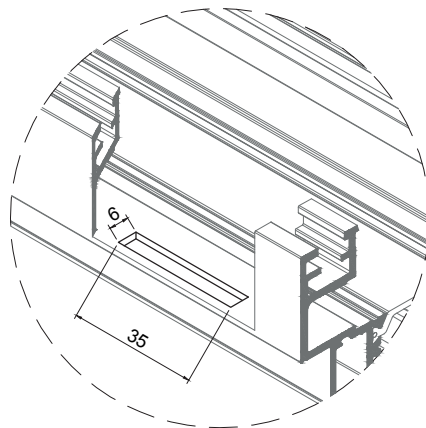
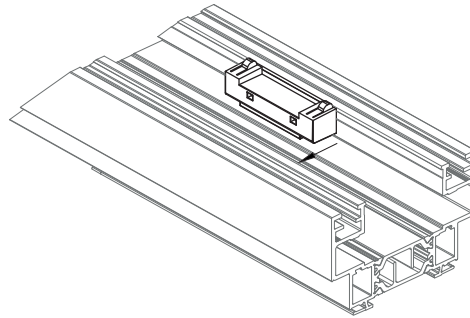
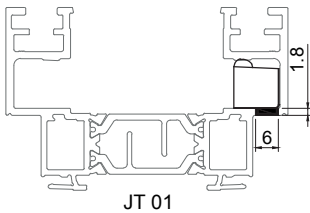

**SILICONE NEUTRO**  
NEUTRAL SILICONE  
SILICONE NEUTRE

**2.2 - Colocar as goteiras pelo exterior do perfil e fixá-las com pontos de cola. Seguir este procedimento em todos os perfis de aro fixo PT.**

Place the drips from the outside of the profile and fix them with glue points. Follow this procedure in all PT fixed frame profiles.

Placer les lapets à volet à l'extérieur du profilé et fixer-les avec des points de colle. Suivre cette procédure sur tous les profilés dormant PT.

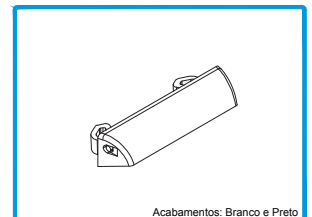

Acabamentos: Branco e Preto  
**210268** GOTEIRA C/ VÁLV. SVE

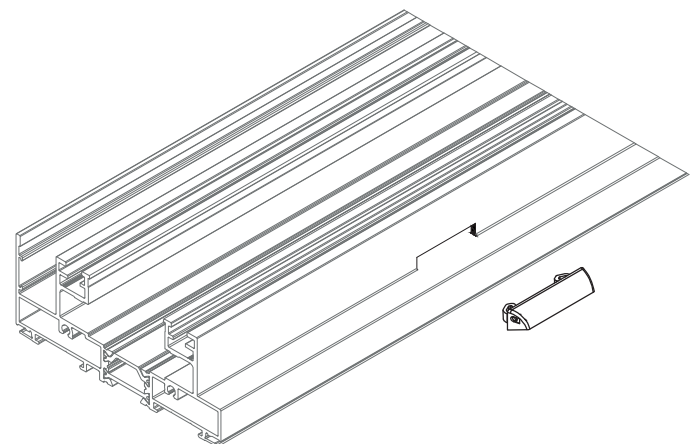
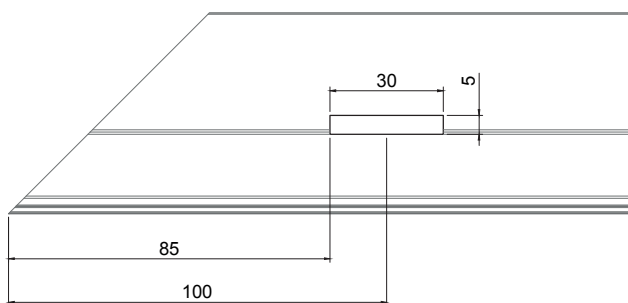
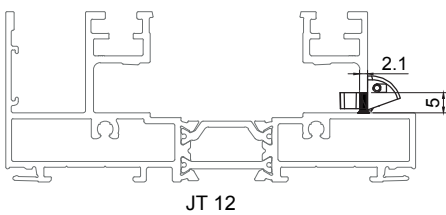

## MONTAGEM DOS PERFIS ARO FIXO FR E PT (CORTE 45°)

FR E PT FIXED FRAME PROFILES ASSEMBLY (45° CUT)

ASSEMBLAGE DES PROFILÉS DORMANT FR ET PT (COUPE 45°)

### 3 - Colocação dos perfis PVC U nos aros fixos. **Seguir este procedimento em todos os perfis de aro fixo FR e PT.**

U PVC profiles placing in fixed frames. **Follow this procedure in all fixed frame profiles FR and PT.**

Mise en place des profilés PVC U sur les cadres dormants. **Suivre cette procédure sur tous les profilés dormant FR et PT.**

#### PASSO | STEP | ÉTAPE 1:

Colocar os perfis PVC inferior e superior.

Place the lower and upper PVC profiles.

Placer les profilés PVC inférieures et supérieures.

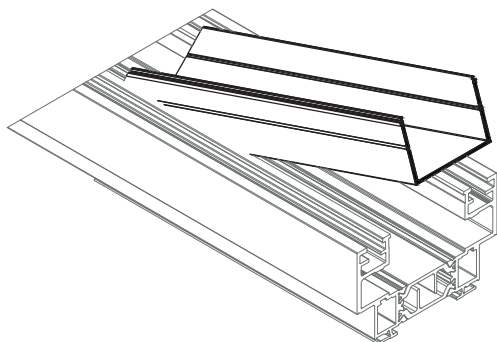

#### PASSO | STEP | ÉTAPE 2:

Colocar as alturas.

Place the heights.

Mettre les hauteurs.

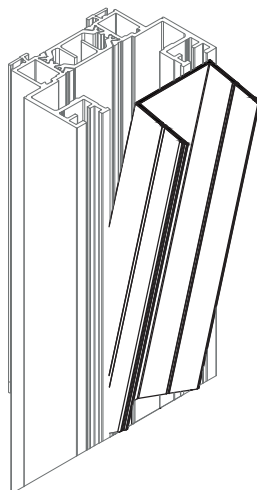

#### IMPORTANTE | IMPORTANT | IMPORTANT:

O conjunto de estanqueidade e as goteiras ocultas (no aro fixo FR) já deverão estar aplicadas na soleira antes desta operação.

Central waterproofing pile seal kit and flap valve (in the FR fixed frame) must already be applied in the sill profile before this operation.

Le kit brosse centrale d'étanchéité et les clapets à volet cachées (dans le cadre dormant FR) doivent déjà être appliqués sur le seuil avant cette opération.

### 4 - Aplicação de silicone nos aros fixos.

Silicone applying in fixed frames.

Application de silicone sur le cadre dormant.

#### 4.1 - Aplicar silicone à cor do perfil ou silicone neutro na zona das esquadrias.

**Seguir este procedimento em todos os perfis de aro fixo FR e PT.**

Apply silicone in the same color as the profiles or neutral silicone in the frame's areas. **Follow this procedure in all fixed frame FR and PT profiles.**

Appliquer du silicone sur la couler des profilés ou du silicone neutre dans la zone des cadres. **Suivre cette procédure sur tous les profilés dormant FR et PT.**

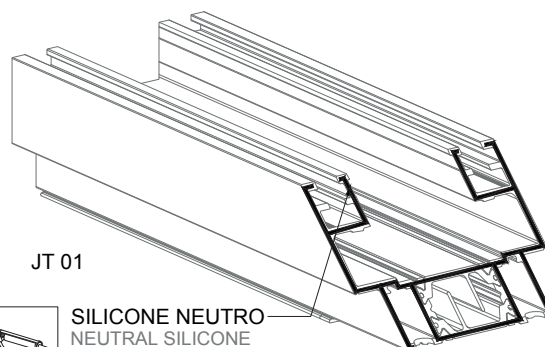
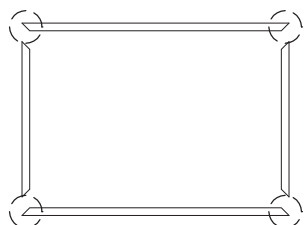

SILICONE NEUTRO  
NEUTRAL SILICONE  
SILICONE NEUTRE

#### 4.2 - Antes de colocar os esquadros, encher as câmaras dos perfis fixos com silicone neutro, de modo a ficarem seladas. **Seguir este procedimento em todos os perfis de aro fixo FR e PT, apenas na zona inferior do caixilho.**

Before placing the corner cleats, the fixed frame profiles chambers must be filled with neutral silicone, in order to be sealed. **Follow this procedure in all the fixed frame FR and PT profiles, only in the lower zone of the frame.**

Avant d'installer les équerres, les chambres des profilés dormants doivent être remplies de silicone neutre afin d'être scellées. **Suivre cette procédure sur tous les profilés dormant FR et PT, uniquement dans la zone inférieure du cadre.**

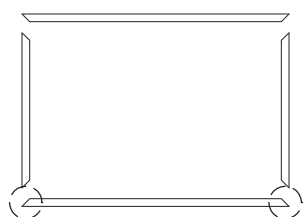

SILICONE NEUTRO  
NEUTRAL SILICONE  
SILICONE NEUTRE

**MONTAGEM DOS PERFIS ARO FIXO FR E PT (CORTE 45°)**  
FR E PT FIXED FRAME PROFILES ASSEMBLY (45° CUT)  
ASSEMBLAGE DES PROFILÉS DORMANT FR ET PT (COUPE 45°)

**5 - Aplicação de esquadros de aperto e cantos de alinhamento nos aros fixos.**  
Corner cleats and the alignment corners applying in fixed frames.  
Application des équerres et les angles d'alignement sur le cadre dormant.

**5.1 - Posicionamento de cada acessórios no respetivo local.**  
Positioning of each accessory in the respective location.  
Positionnement de chaque accessoire dans l'emplacement respectif.

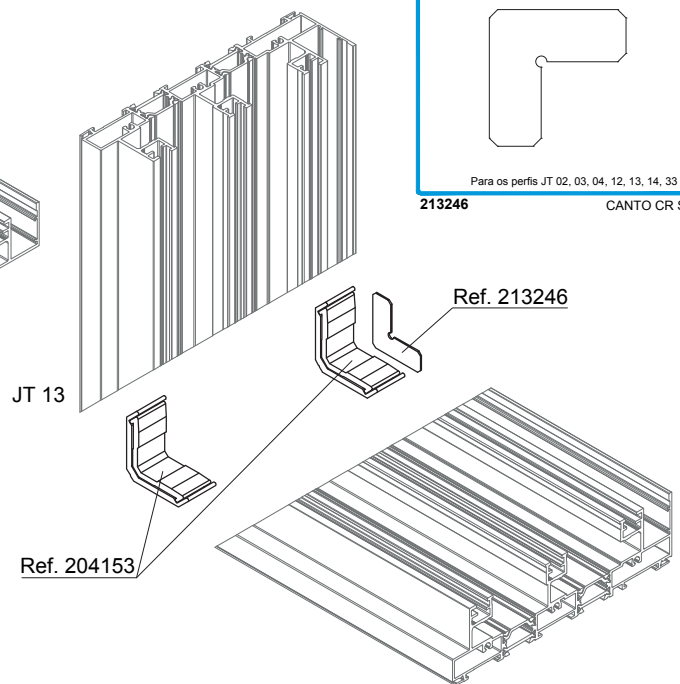
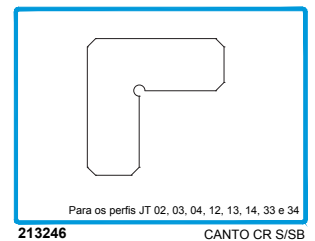
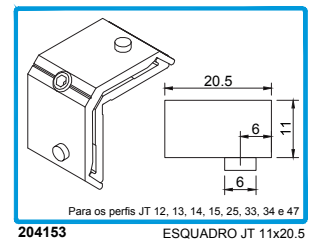
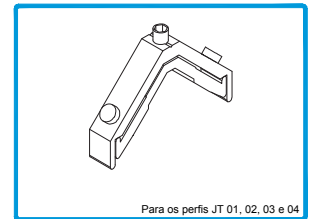
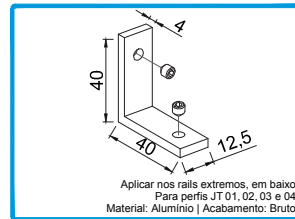
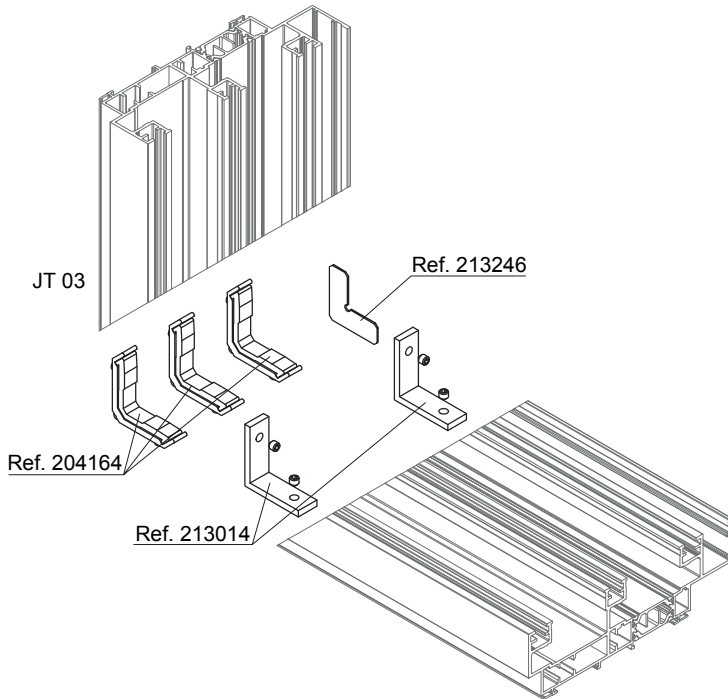

**5.2 - Aperto dos pernos dos cantos de alinhamento.**  
Tighten the alignment corner threaded pins.  
Serrage des bout cuvettes des équerres d'alignement.

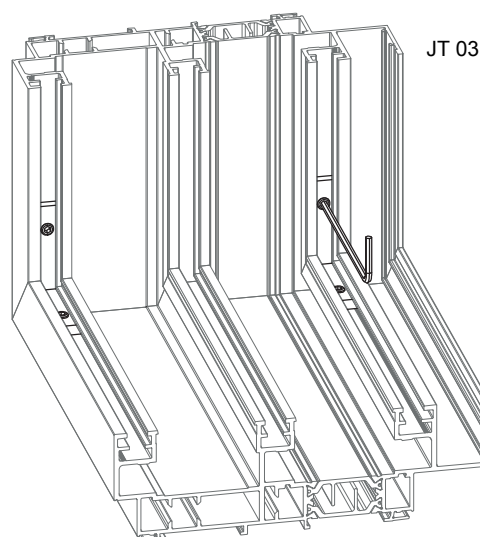



**MONTAGEM DOS PERFIS ARO FIXO FR E PT (CORTE 45°)**  
FR E PT FIXED FRAME PROFILES ASSEMBLY (45° CUT)  
ASSEMBLAGE DES PROFILÉS DORMANT FR ET PT (COUPE 45°)

**6 - Colocação dos corta-ventos nos aros fixos.**

Central waterproofing pile seal placing in fixed frames.  
Placement des brosses centrale d'étanchéité sur les cadres dormants.

Em primeiro colocar os corta-ventos na soleira. Os corta-ventos da padieira deverão ser colocados depois das folhas de correr já estarem aplicadas. **Seguir este procedimento em todos os perfis de aro fixo FR e PT.**

First place the lower central waterproofing pile seals on the sill. The lintel central waterproofing pile seals must be placed after the sliding sashes are already applied. Follow this procedure in all fixed frame FR and PT profiles.

En premier placer les brosses centrale d'étanchéité sur le seuil. Les brosses centrale d'étanchéité sur le linteau doivent être placés après que les vantaux coulissants sont déjà appliquées. **Suivre cette procédure sur tous les profilés dormant FR et PT.**

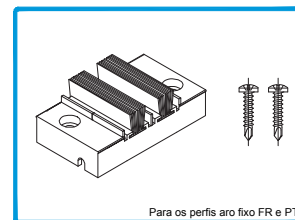

213286 Para os perfis aro fixo FR e PT CORTA-VENTO JT

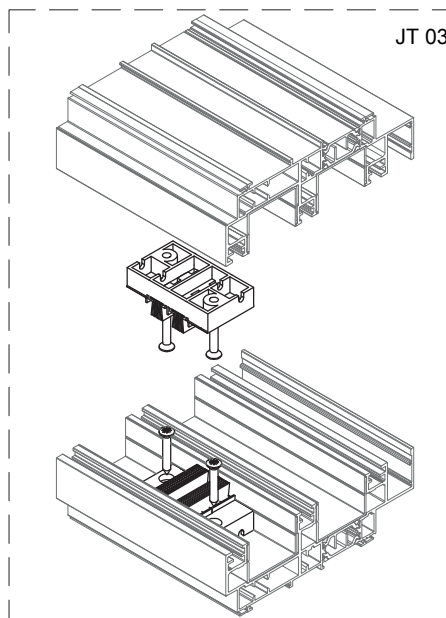
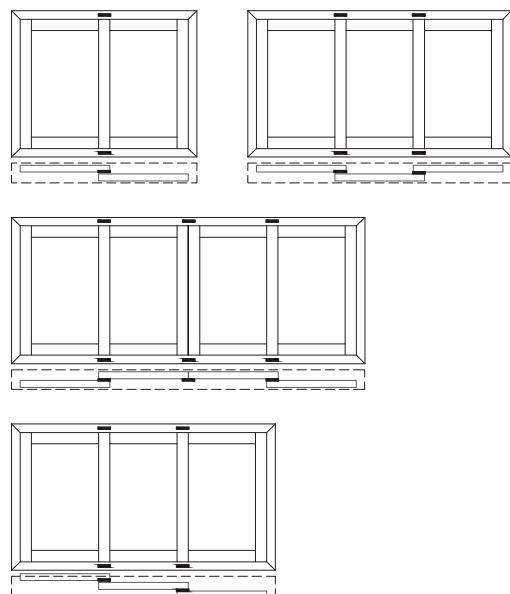

**7 - Colocação dos perfis PVC T nos aros fixos. Seguir este procedimento em todos os perfis de aro fixo FR e PT.**

T PVC profiles placing in fixed frames. Follow this procedure in all fixed frame profiles FR and PT.  
Mise en place des profilés PVC T sur les dormants. Suivre cette procédure sur tous les profilés dormant FR et PT.

**7.1 - Os perfis PVC T verticais são aplicados numa única peça, enquanto que os horizontais são divididos em várias peças.**

Vertical T PVC profiles are applied in a single piece, while the horizontal ones are divided into several pieces.  
Les profilés PVC T verticaux sont appliqués en une seule pièce, tandis que les profilés horizontaux sont divisés en plusieurs pièces.

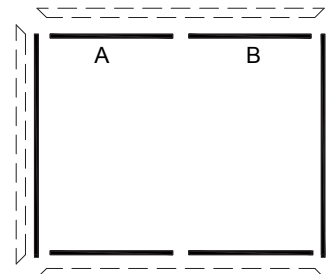

**7.2 - Colocar primeiro as alturas e só depois as larguras.**

Place the heights first and only then the widths  
Mettre d'abord les hauteurs, puis les largeurs.

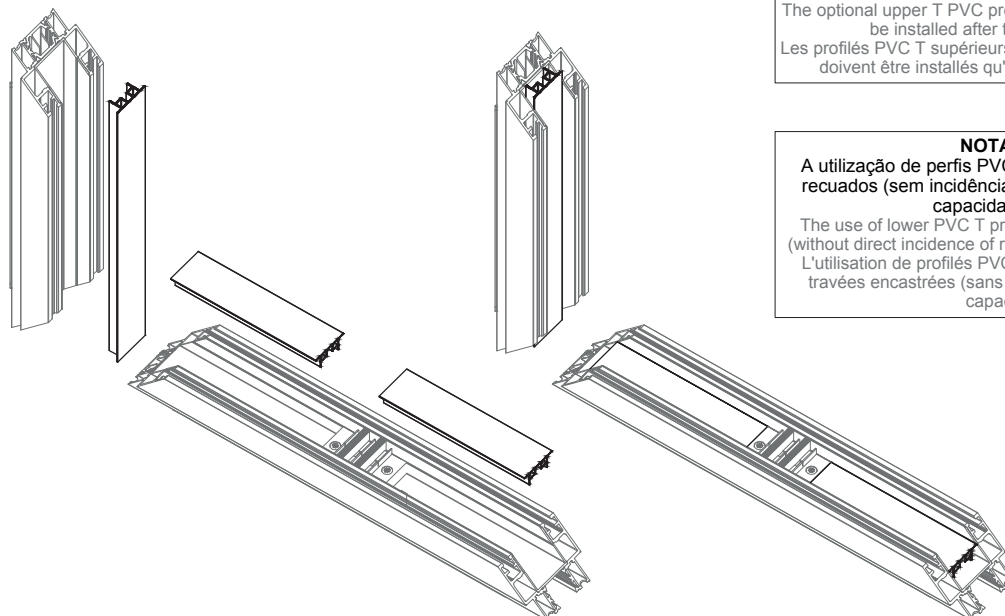

**IMPORTANTE | IMPORTANT | IMPORTANT:**  
Os perfis PVC T superiores opcionais (A e B, no esquema acima) só deverão ser colocados depois das folhas de correr já estarem aplicadas.  
The optional upper T PVC profiles (A and B, in the scheme above) should only be installed after the sliding sashes are already applied.  
Les profilés PVC T supérieurs en option (A et B, dans le schéma ci-dessus) ne doivent être installés qu'après l'application des plaques coulissantes.

**NOTA | NOTE | REMARQUE:**  
A utilização de perfis PVC T inferiores é apenas aconselhada em vãos recuados (sem incidência direta da chuva), uma vez que diminuem a capacidade de escoamento de água.  
The use of lower PVC T profiles is only recommended in recessed frames (without direct incidence of rain), as they reduce the water drainage capacity.  
L'utilisation de profilés PVC T inférieurs n'est recommandée que dans les travées encastrées (sans incidence directe de pluie), car ils réduisent la capacité d'évacuation de l'eau.



**MONTAGEM DOS PERFIS ARO FIXO FR E PT (CORTE 45°)**  
FR E PT FIXED FRAME PROFILES ASSEMBLY (45° CUT)  
ASSEMBLAGE DES PROFILÉS DORMANT FR ET PT (COUPE 45°)

**8 - Aplicação da pelúcia 7x10 Tri-Fin nos perfis de capa.**  
7x10 Tri-Fin pile seal application to cover profiles.  
Application de la joint brossse 7x10 Tri-Fin sur les profilés de capot.

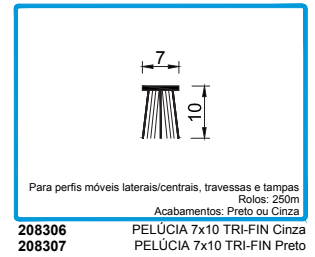
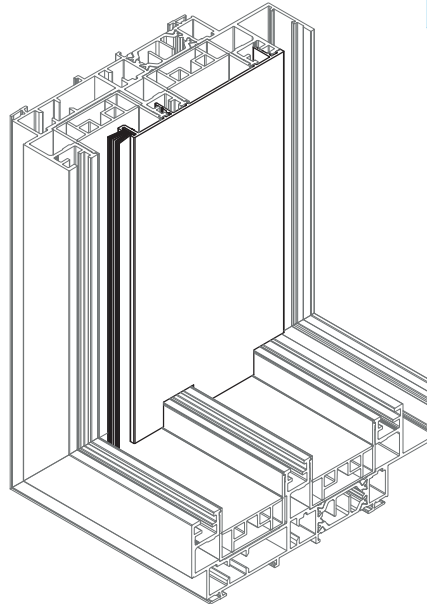
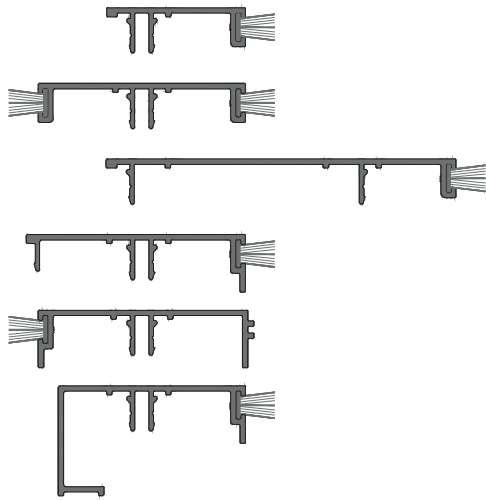

**9 - Aplicação do perfil guia JT87 nas soleiras.**  
Applying of JT87 rail profile in the sills.  
Appliquer le profilé de guide JT87 sur les seuils.

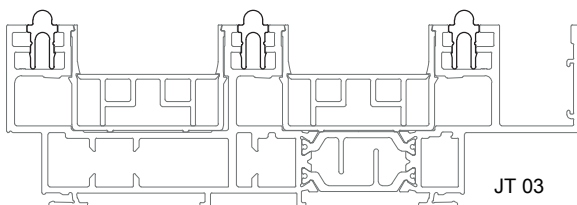

**NOTA | NOTE | REMARQUE:**  
Em perfis anodizados, a guia JT87 deverá ser aplicada com um cordão de silicone neutro.  
On anodised profiles the JT87 guide should be applied with a neutral silicone cord.  
Sur les profis anodisés, le guide JT87 doit être appliqué avec un cordon de silicone neutre.

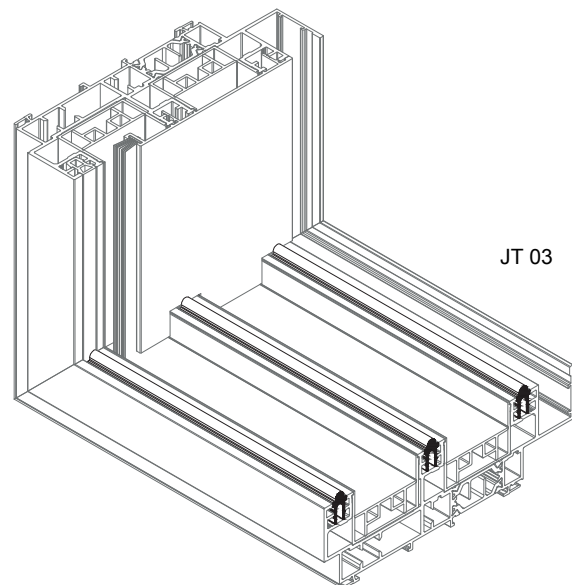
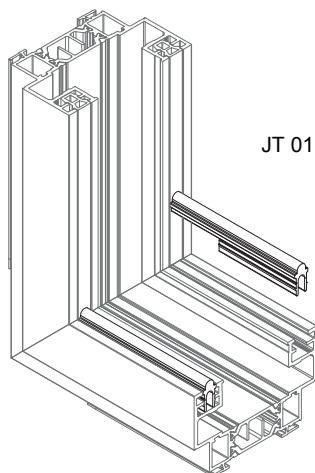

**MONTAGEM DOS PERFIS ARO FIXO FR E PT (CORTE 45°)**  
FR E PT FIXED FRAME PROFILES ASSEMBLY (45° CUT)  
ASSEMBLAGE DES PROFILÉS DORMANT FR ET PT (COUPE 45°)

10 - Aplicação frontal dos contra-fechos nos aros fixos.  
Locking plates frontal application in fixed frames.  
Application frontale des contre-fermetures sur les dormants.

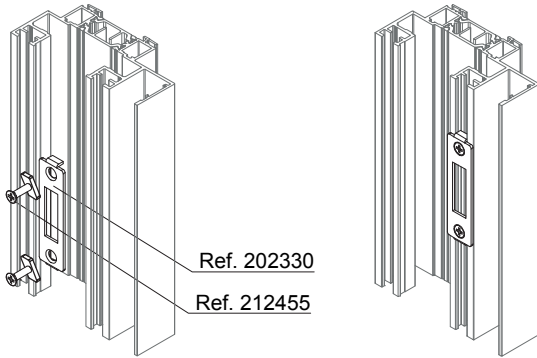

Ref. 202330  
Ref. 212455

**FERRAGEM 1 PONTO/MULTIPONTO ALU**  
1 POINT/MULTIPOINT HARDWARE | SERRURE 1 POINT/MULTIPOINT

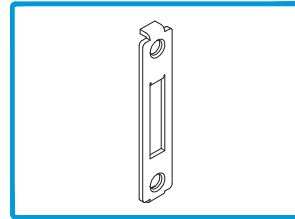

202330 CONTRA-FECHO ALU

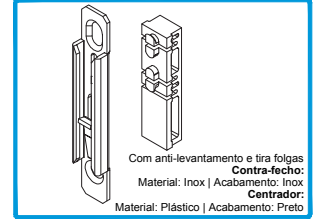

202491 CONTRA-FECHO ANTI-LEV. MULT.  
202487 CENTRADOR JT P/ G-FECHO AL M.

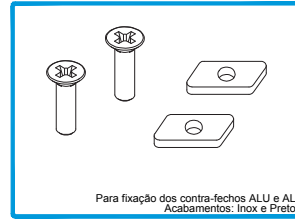

212455 CONJ. FIX. CONTRA-FECHO AL MULTIP. JT

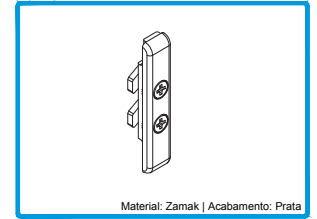

202492 CONTRA-FECHO SOT

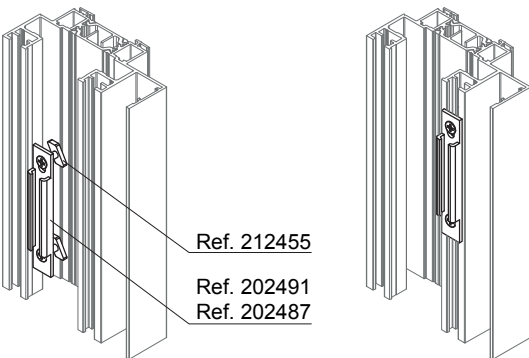

Ref. 212455  
Ref. 202491  
Ref. 202487

**FERRAGEM MULTIPONTO SOS**  
MULTIPOINT HARDWARE | SERRURE MULTIPOINT

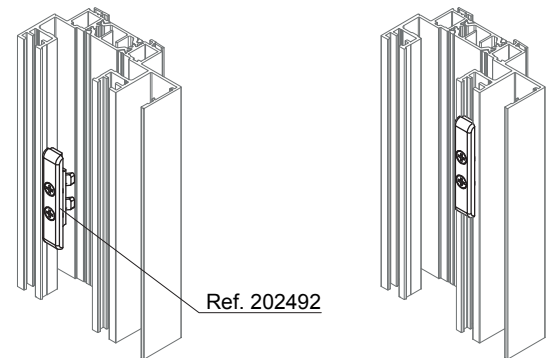

Ref. 202492

**FERRAGEM MULTIPONTO SOT**  
MULTIPOINT HARDWARE | SERRURE MULTIPOINT

11 - Aplicação da junta tapa canal 2116 nos aros fixos. Esta junta deverá ser aplicada na padieira e nas laterais. Nas zonas onde se localizarão os contra-fechos, a junta deverá ser interrompida.  
2116 channel cover joint applying in fixed frames. This joint must be applied in the lintel and the laterals. In the zones where the counter-locks will be located, the joint must be interrupted.  
Application de la joint de couverture du canal 2116 sur les cadres dormants. Ce joint doit être appliqué sur le linteau et les côtés. Dans les zones où seront situées les contre-serrures, le joint doit être interrompu.

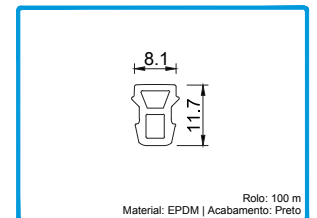

208348 JUNTA TAPA CANAL 2116 JT

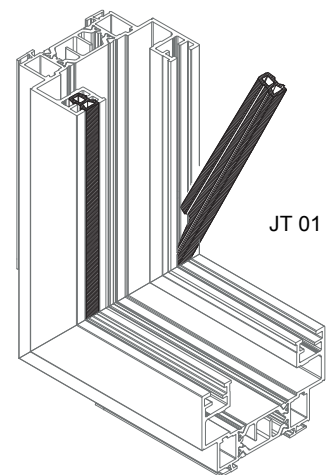
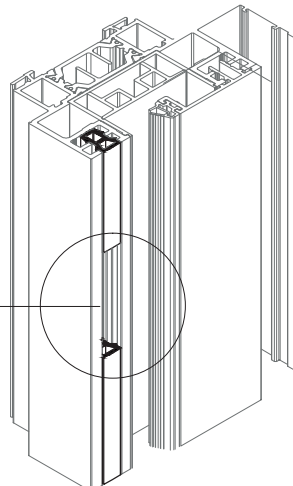
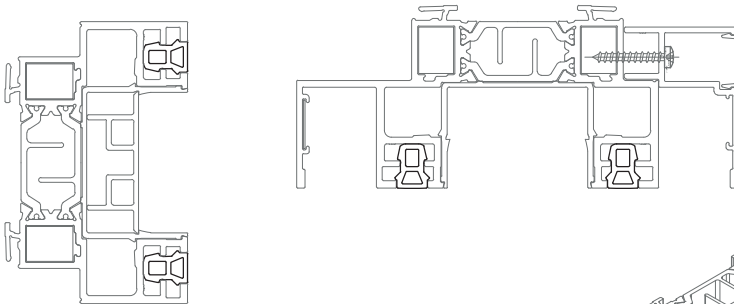

JT 01

**Zona de localização do contra-fecho** (a esta folga dever-se-à adicionar a altura de funcionamento do gancho, no caso da ferragem multiponto SOT)  
Locking plate location zone (to this gap must be added the working height of the hook, in the case of SOT multipoint hardware)  
**Zone d'emplacement de contre-verrouillage** (la hauteur du crochet doit être ajoutée à cet espace, dans le cas du matériel multipoint SOT)

**IMPORTANTE | IMPORTANT | IMPORTANT:**  
A zona de interrupção da junta deverá ser suficiente para permitir os movimentos do fecho multiponto SOT.  
The joint interruption zone must be sufficient to allow the movements of the SOT multipoint lock.  
La zone d'interruption de la joint doit être suffisante pour permettre les mouvements de la serrure multipoint SOT.

**MONTAGEM DOS PERFIS ARO FIXO FR E PT (CORTE 45°)**  
FR E PT FIXED FRAME PROFILES ASSEMBLY (45° CUT)  
ASSEMBLAGE DES PROFILÉS DORMANT FR ET PT (COUPE 45°)

12 - Montagem de aros fixos, em tipologias de canto 90°.  
Fixed frames assembly, in 90° corner typologies.  
Montage de cadres dormant, en types d'angle à 90°.

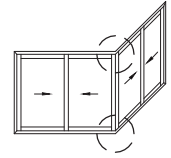

12.1 - Encher as câmaras com silicone e aplicar silicone à cor do perfil ou silicone neutro na zona das esquadrias. **Seguir este procedimento em todos os perfis de aros fixos.**

Fill the chambers with silicone and apply silicone in the same color as the profiles or neutral silicone in the frame's areas. **Follow this procedure in all fixed frame profiles.**

Remplir les chambres de silicone et appliquer du silicone sur la couleur du profilé ou du silicone neutre dans la zone des cadres. **Suivre cette procédure sur tous les profilés de cadre dormant.**

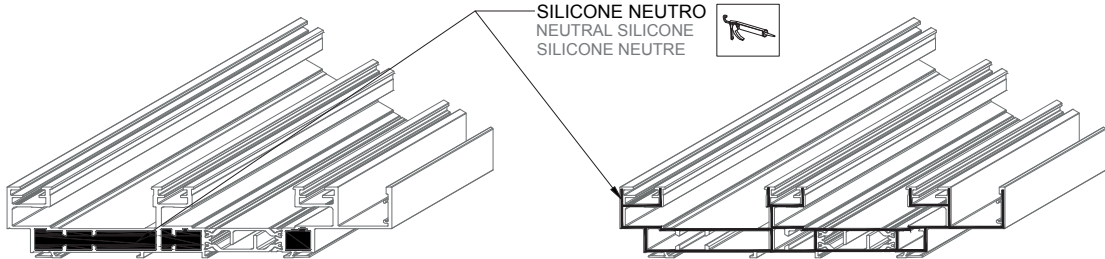

12.2 - Colocar as peças que constituem o conjunto união e os esquadros inox canto 90° nos perfis e fixá-los com pernos M4x16. **Seguir este procedimento em todos os perfis de aros fixos.**

Place the 90° corner union kit pieces and corners and fix them with M4x16 threaded pins. **Follow this procedure in all fixed frame profiles.**

Placer les pièces qui composent le kit d'union et les angles en acier inox à 90° sur les profilés et fixer-les avec des bout cuvettes M4x16. **Suivre cette procédure sur tous les profilés de cadre dormant.**

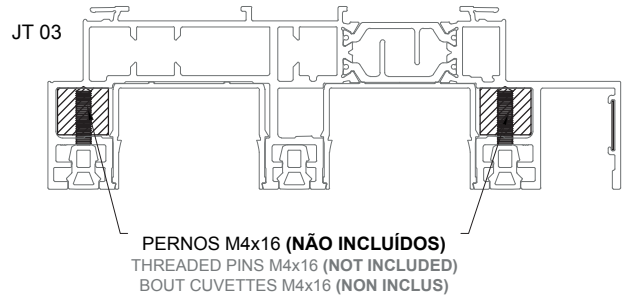
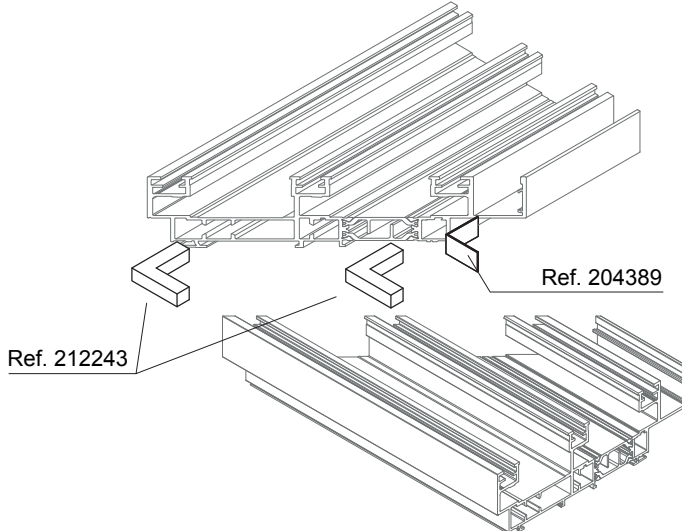
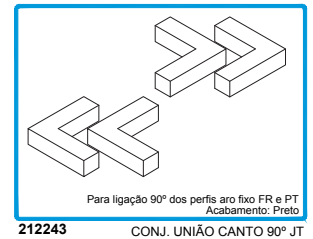
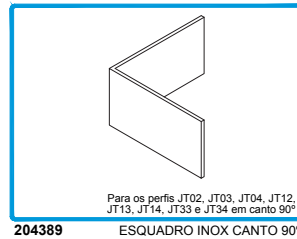

12.3 - Aplicar os Conjunto de estanqueidade na zona do corta-vento 90°. **Seguir este procedimento em todos os perfis de aro fixo FR e PT.**

Apply the Central waterproofing pile seal kits in the 90° Central gasket area. **Follow this procedure in all fixed frame profiles FR and PT.**

Appliquer les Kits brosse centrale d'étanchéité dans la zone du brosse centrale d'étanchéité à 90°. **Suivre cette procédure sur tous les profilés dormant FR et PT.**

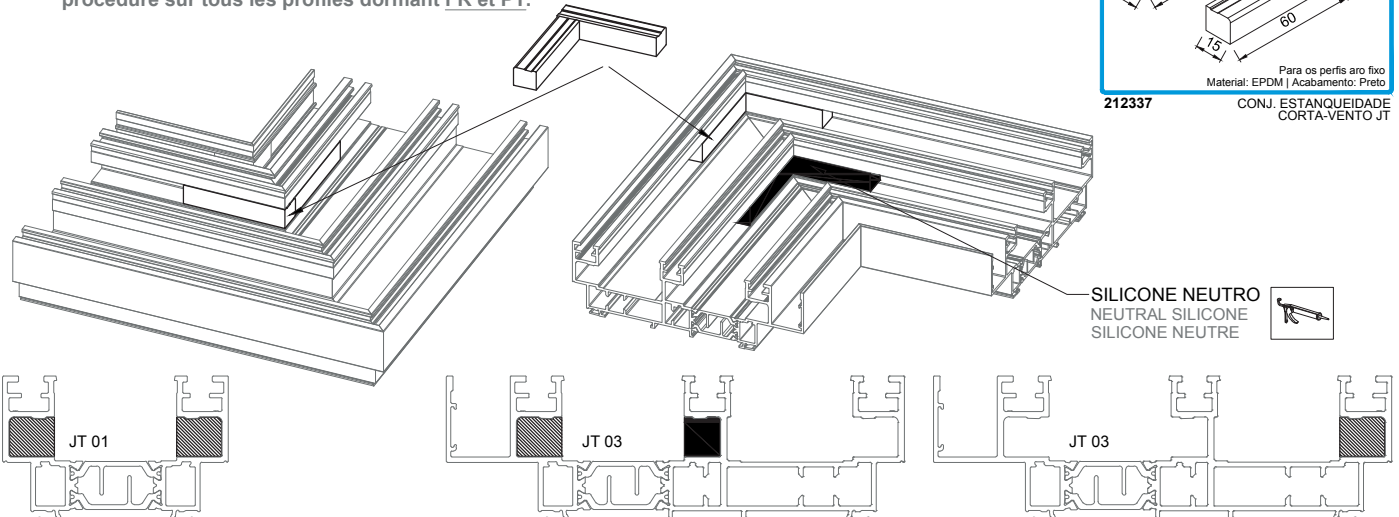
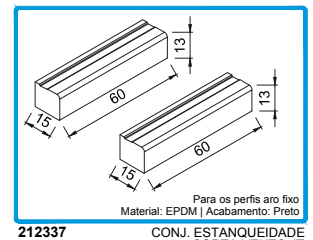

**MONTAGEM DOS PERFIS ARO FIXO FR E PT (CORTE 45°)**  
FR E PT FIXED FRAME PROFILES ASSEMBLY (45° CUT)  
ASSEMBLAGE DES PROFILÉS DORMANT FR ET PT (COUPE 45°)

12 - Montagem de aros fixos, em tipologias de canto 90°.  
Fixed frames assembly, in 90° corner typologies.  
Montage de cadres dormant, en types d'angle à 90°.

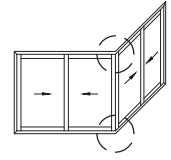

12.3 - Os perfis PVC U são cortados a 45° mas os perfis PVC T são cortados a 90°.  
PVC U profiles are cut at 45° but PVC T profiles are cut at 90°.  
Les profilés PVC U sont coupés à 45° mais les profilés PVC T sont coupés à 90°.

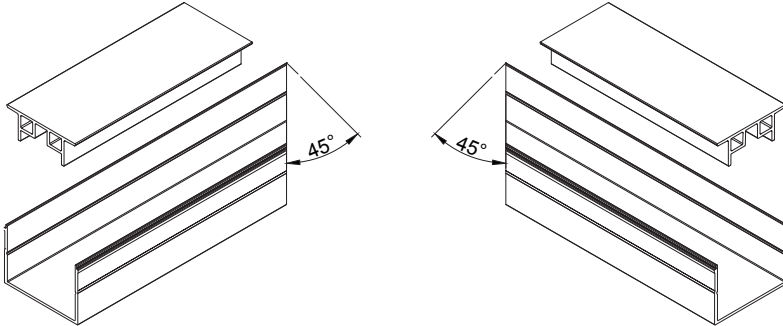

12.4 - Aplicar o corta-vento canto 90° JT no aro fixo.  
Apply the 90° corner insulation gasket in the fixed frame.  
Appliquer le brossse d'étanchéité angle 90°.

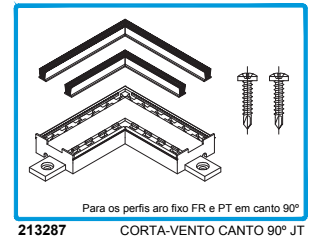

As medidas de corte dos perfis PVC T encontram-se no mapa de quantidades das tipologias de canto.  
The cutting measures of the T PVC profiles can be found in the corners typologies quantity map.  
Les mesures de coupe des profilés PVC T se trouvent dans la carte de quantité des typologies d'angle.

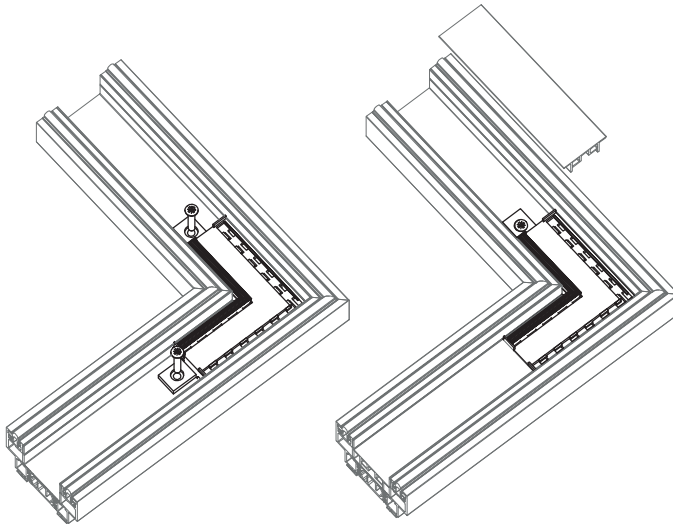

**IMPORTANTE | IMPORTANT | IMPORTANT:**  
Os perfis PVC T superiores só deverão ser colocadas depois de os aros móveis estarem aplicados.  
The upper T PVC profiles must only be installed after the mobile frames are applied.  
Les profilés PVC T supérieures ne doivent être installés qu'après la pose des cadres ouvrants.

13 - Aplicação do Conjunto união reta JT nos aros fixos, em emendas de perfis de aro fixo.  
Straight union kit and angles applying in fixed frames, in splicing of fixed frame profiles.  
Application de l'assemblage de joints droits JT sur les jantes fixes, dans l'épissage de profilés de cadre dormant.

13.1 - Colocar as peças que constituem o Conjunto união reta JT no interior dos perfis e fixá-las com pernos M4x16. Seguir este procedimento em todos os perfis de aros fixos.  
Place the pieces that constitute the straight union kit inside the profiles and fix them with M4x16 threaded pins.  
Follow this procedure in all fixed frame profiles.  
Placer les pièces qui composent le jeu d'union droite JT à l'intérieur des profilés et fixer-les avec des bout cuvettes M4x16. Suivre cette procédure sur tous les profilés de cadre dormant.

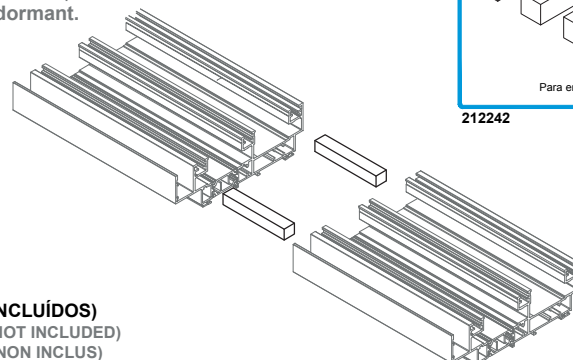
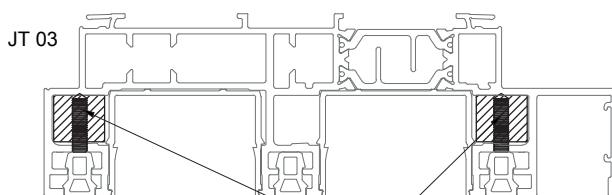
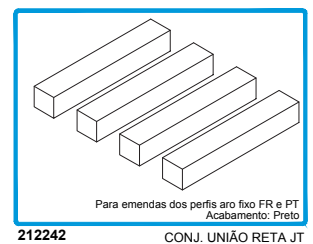

PERNOS M4x16 (NÃO INCLuíDOS)  
THREADED PINS M4x16 (NOT INCLUDED)  
BOUT CUVETTES M4x16 (NON INCLUS)

**MONTAGEM DOS PERFIS ARO FIXO PARA TIPOLOGIAS FIXAS (CORTE 45°)**

FIXED TYPOLOGIES FIXED FRAME PROFILES ASSEMBLY (45° CUT)

ASSEMBLAGE DES PROFILÉS DORMANT POUR TYPOLOGIES FIXES (COUPE 45°)

**1 - Colocação do conjunto de estanqueidade para corta-vento nos aros fixos.**

Central waterproofing pile seal kit placing in fixed frames.

Mise en place du kit brosse centrale d'étanchéité pour les cadres dormants.

Colocar o conj. de estanqueidade, apenas em baixo, no cruzamento das folhas onde posteriormente levará o perfil PVC U e os corta-ventos.

Place the central waterproofing pile seal kit, only on the bottom, at the intersection of the sashes where later the U PVC profile and the central gasket will be.

Placer le kit brosse centrale d'étanchéité, juste en bas, à l'intersection des vantaux où prendront plus tard le profilé PVC U et les brosses centrales d'étanchéité.

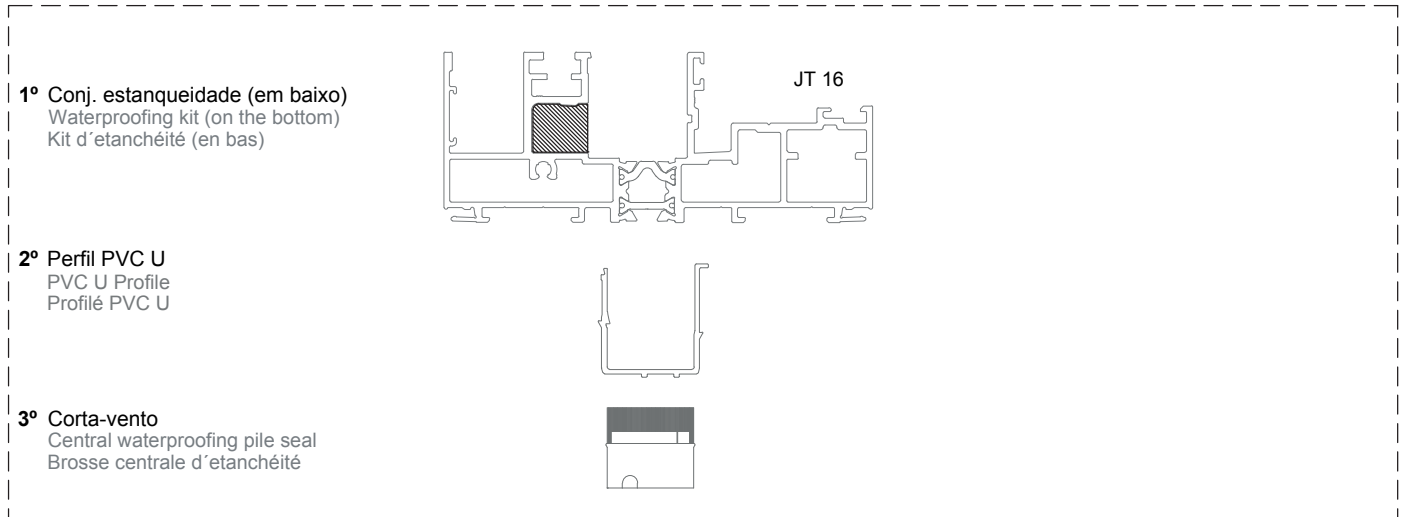
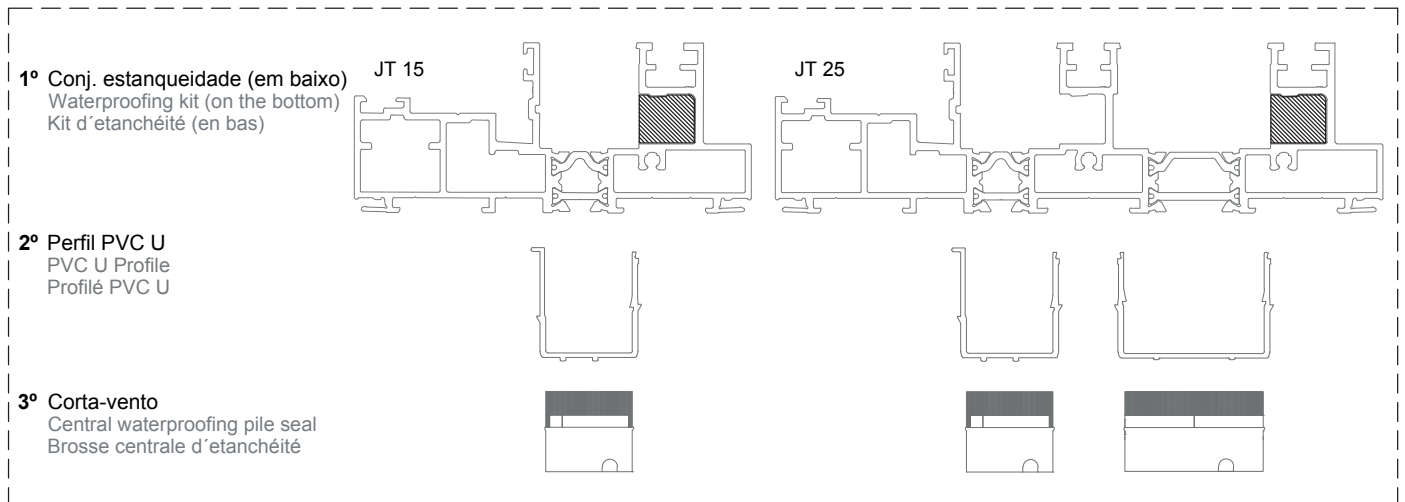
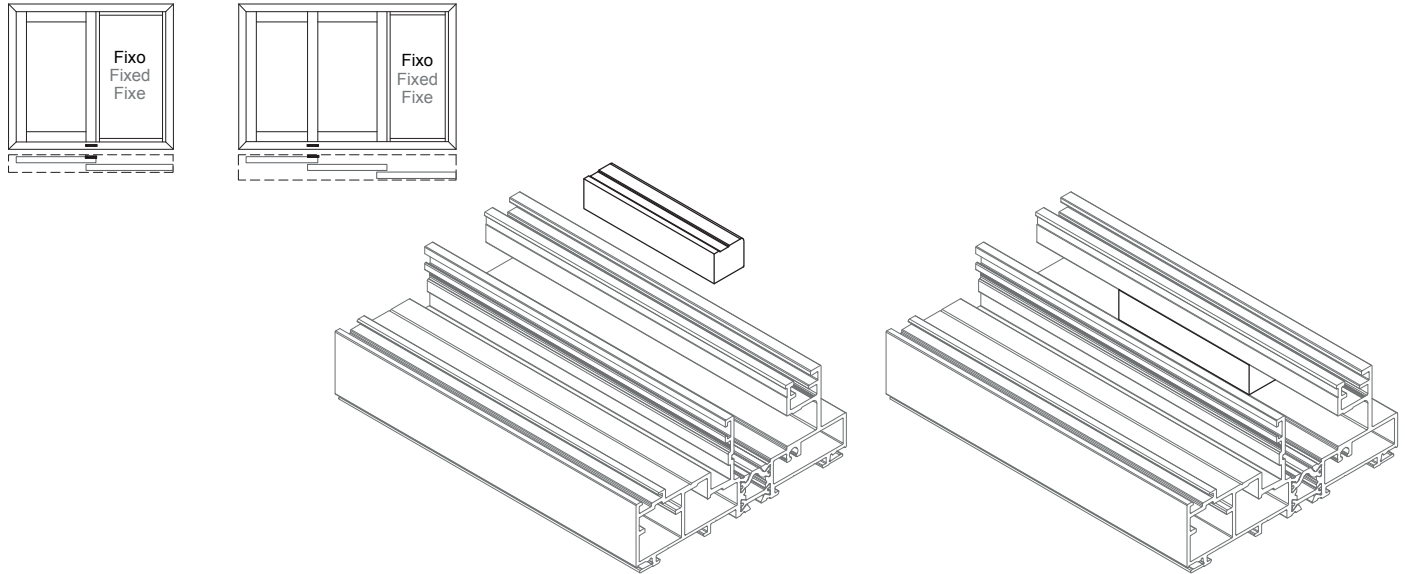
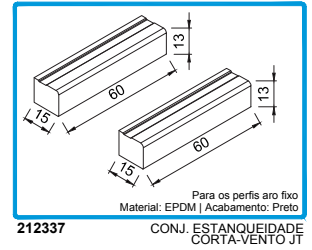



**MONTAGEM DOS PERFIS ARO FIXO PARA TIPOLOGIAS FIXAS (CORTE 45°)**  
FIXED TYPOLOGIES FIXED FRAME PROFILES ASSEMBLY (45° CUT)  
ASSEMBLAGE DES PROFILÉS DORMANT POUR TYPOLOGIES FIXES (COUPE 45°)

**2 - Colocação de goteiras nos aros fixos.**

Drips placing in fixed frames.  
Placement des clapets sur les cadres dormants.

Colocar as goteiras pelo exterior do perfil e fixá-las com pontos de silicone nas extremidades.  
Place the drips from the outside of the profile and fix them with silicone points at the edges.  
Placer les lapets à volet extérieur à l'extérieur du profilé et fixer-les avec des points de silicone aux extrémités.

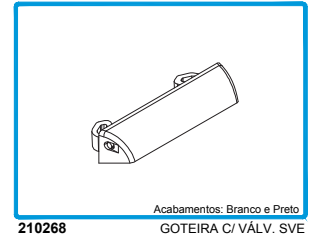

Acabamentos: Branco e Preto  
GOTEIRA C/ VÁLV. SVE

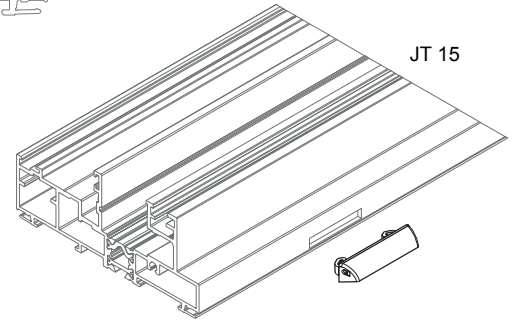
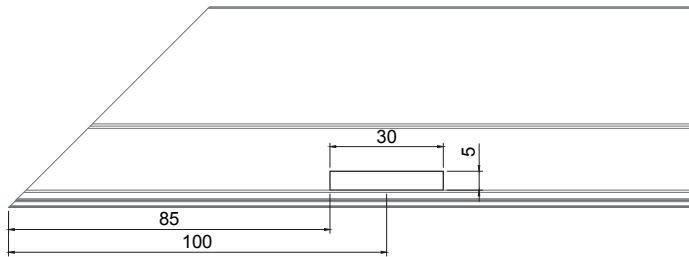
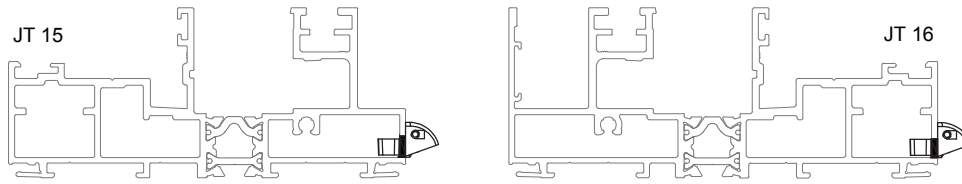

**3 - Colocação dos perfis PVC U no aro fixo.**

U PVC profiles placing to the fixed frame.  
Mise en place des profilés PVC U sur le cadre dormant.

**IMPORTANTE | IMPORTANT | IMPORTANT:**

O conjunto de estanqueidade já deverá estar aplicado na soleira antes desta operação.  
Central waterproofing pile seal kit must already be applied in the sill profile before this operation.  
Le kit brosse centrale d'étanchéité doit déjà être appliqué sur le seuil avant cette opération.

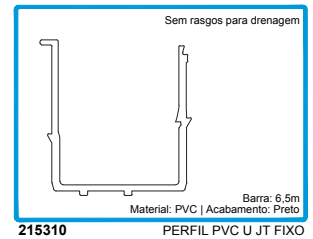
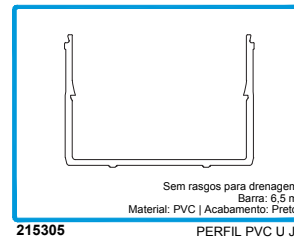

215305 PERFIL PVC U JT 215310 PERFIL PVC U JT FIXO

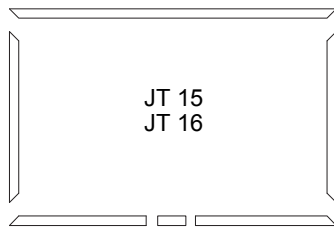

Perfil PVC U com 65mm  
PVC profile with 65mm  
Profilé PVC avec 65mm

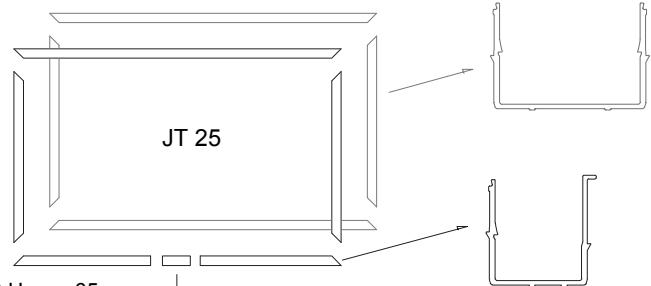

Perfil PVC U com 65mm  
PVC profile with 65mm  
Profilé PVC avec 65mm

**PASSO | STEP | ÉTAPE 1:**

Colocar os perfis PVC inferior e superior.  
Place the lower and upper PVC profiles.  
Placer les profilés PVC inférieures et supérieures.

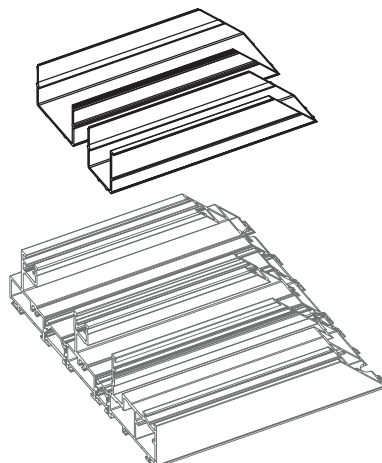

**PASSO | STEP | ÉTAPE 2:**

Colocar as alturas.  
Place the heights.  
Mettre les hauteurs.

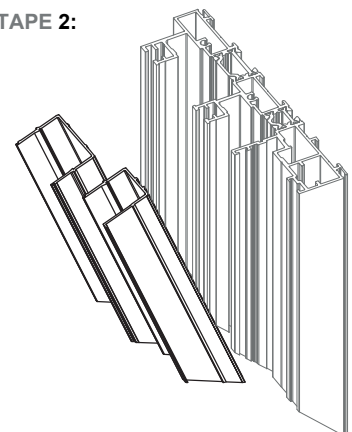

**MONTAGEM DOS PERFIS ARO FIXO PARA TIPOLOGIAS FIXAS (CORTE 45°)**

FIXED TYPOLOGIES FIXED FRAME PROFILES ASSEMBLY (45° CUT)

ASSEMBLAGE DES PROFILÉS DORMANT POUR TYPOLOGIES FIXES (COUPE 45°)

**4 - Aplicação de silicone nos aros fixos.**

Silicone applying in fixed frames.

Application de silicone sur le cadre dormant.

**4.1 - Aplicar silicone à cor do perfil ou silicone neutro na zona das esquadrias.**

Apply silicone in the same color as the profiles or neutral silicone in the frame's areas.

Appliquer du silicone sur la couler des profilés ou du silicone neutre dans la zone des cadres.

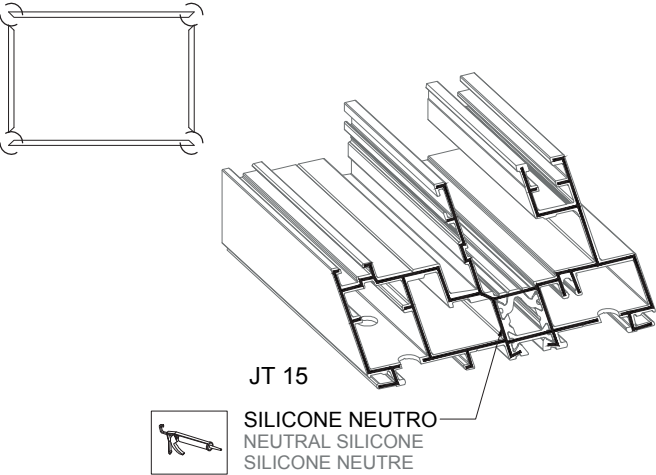

**4.2 - Antes de colocar os esquadros, encher as câmaras dos perfis fixos com silicone neutro, de modo a ficarem seladas.**

Before placing the corner cleats, the fixed frame profiles chambers must be filled with neutral silicone, in order to be sealed.

Avant d'installer les équerres, les chambres des profilés dormants doivent être remplies de silicone neutre afin d'être scellées.

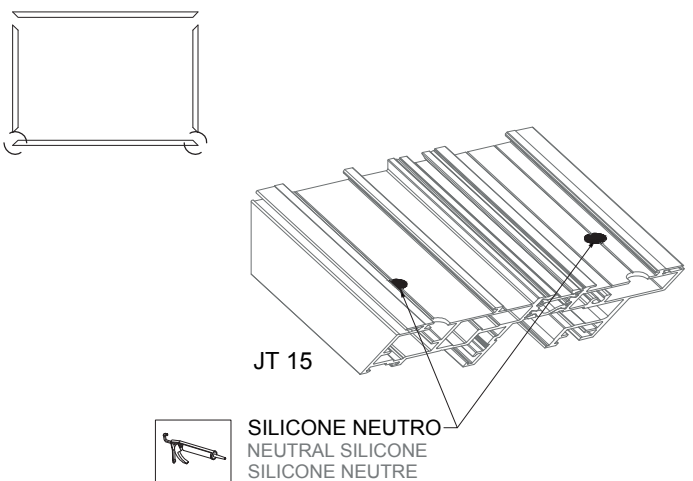

**5 - Aplicação de esquadros de aperto e cantos de alinhamento nos aros fixos.**

Corner cleats and the alignment corners applying in fixed frames.

Application des équerres et les angles d'alignement sur le cadre dormant.

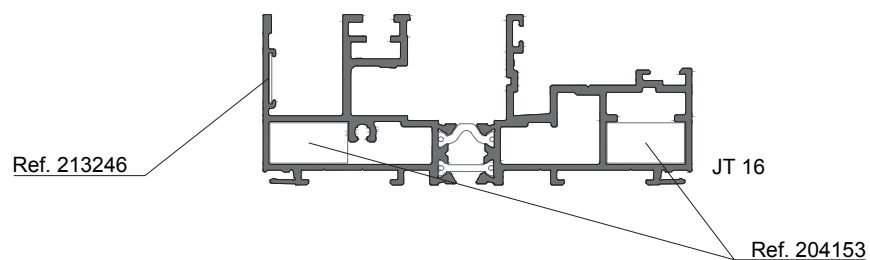
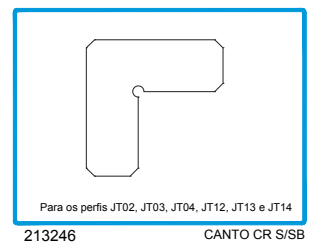
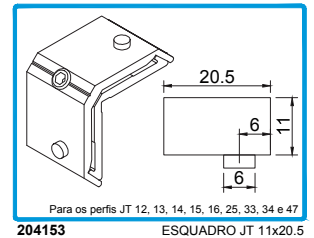
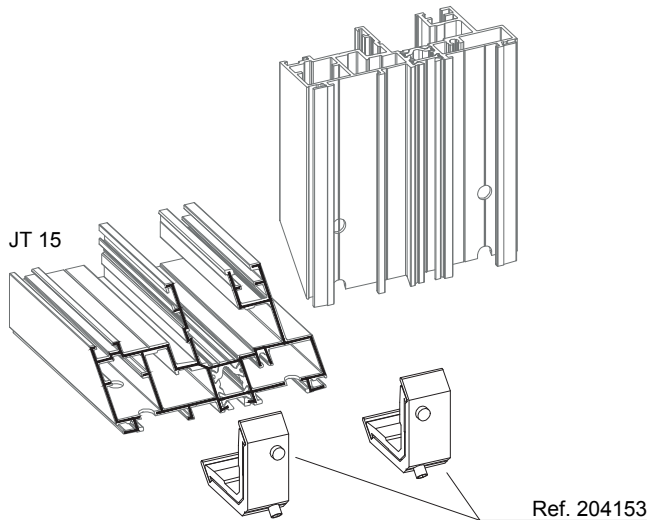



**MONTAGEM DOS PERFIS ARO FIXO PARA TIPOLOGIAS FIXAS (CORTE 45°)**

FIXED TYPOLOGIES FIXED FRAME PROFILES ASSEMBLY (45° CUT)

ASSEMBLAGE DES PROFILÉS DORMANT POUR TYPOLOGIES FIXES (COUPE 45°)

**6 - Colocação dos corta-ventos nos aros fixos.**

Central waterproofing pile seal placing in fixed frames.

Placement des brosses centrale d'étanchéité sur les cadres dormants.

Colocar os corta-ventos na soleira. Os corta-ventos da padieira deverão ser colocados depois das folhas já estarem aplicadas.

Place the lower central waterproofing pile seals on the sill. The lintel central waterproofing pile seals must be placed after the sashes are already applied.

Placer les brosses centrales d'étanchéité sur le seuil. Les brosses centrale d'étanchéité sur le linteau doivent être placés après que les vantaux sont déjà appliquées.

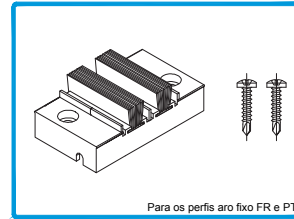

213286

CORTA-VENTO JT

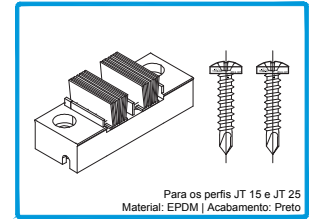

213303

CORTA VENTO JT FIXO

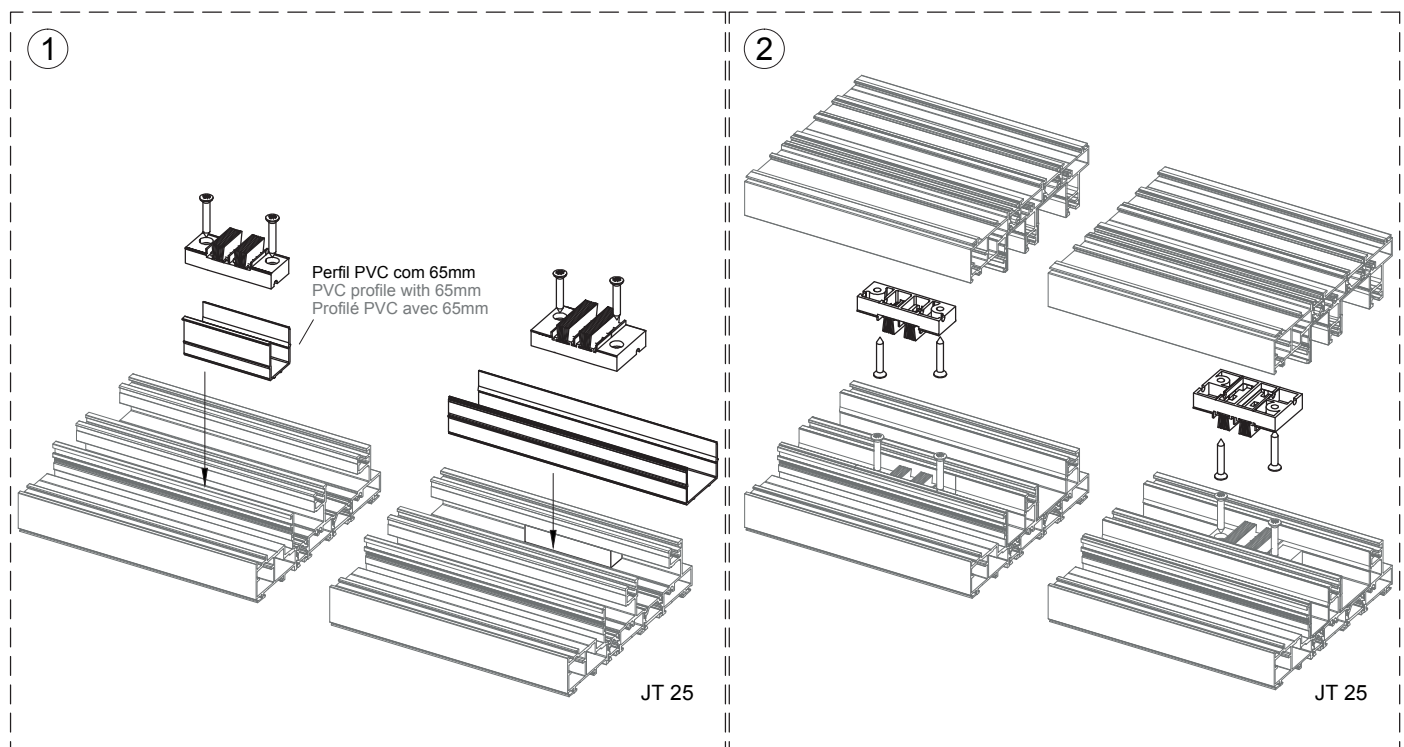
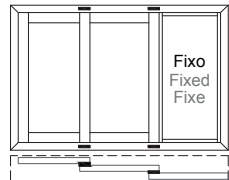

**7 - Aplicação da pelúcia 7x10 Tri-Fin na Junta central VD 2195 JT FIXO.**

7x10 Tri-Fin pile seal application to the Central joint VD 2195 FIXED JT.

Application de la joint brosse 7x10 Tri-Fin sur le Joint central VD 2195 JT FIXE.

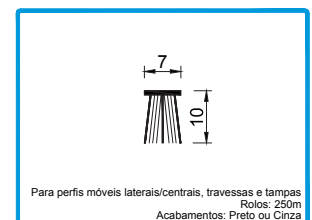
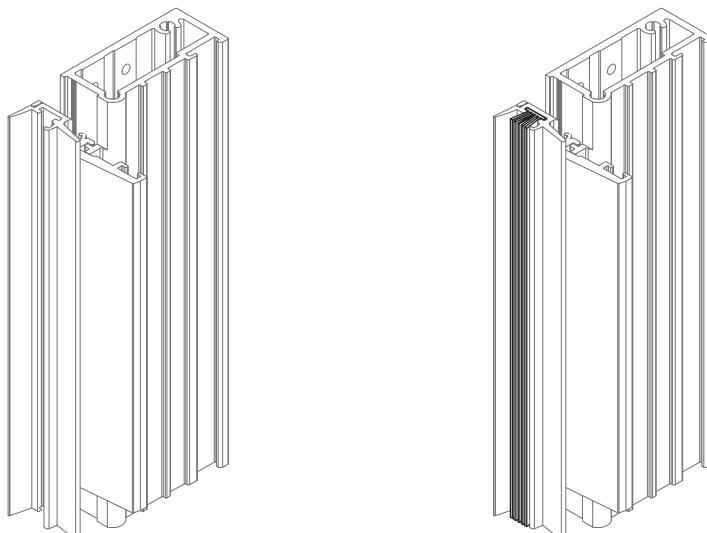

208306  
208307

Para perfis móveis laterais/centrais, travessas e tampas  
Rolos: 250m  
Acabamentos: Preto ou Cinza  
PELÚCIA 7x10 TRI-FIN Cinza  
PELÚCIA 7x10 TRI-FIN Preto

**MONTAGEM DOS PERFIS ARO FIXO PARA TIPOLOGIAS FIXAS (CORTE 45°)**

FIXED TYPOLOGIES FIXED FRAME PROFILES ASSEMBLY (45° CUT)

ASSEMBLAGE DES PROFILÉS DORMANT POUR TYPOLOGIES FIXES (COUPE 45°)

**8 - Aplicação do perfil JT 94 com o Conj. Fixação JT 94.**

JT 94 application using the JT 94 Fixing Kit application.

Application du profilé JT 94 en utilisant le Kit de Fixation JT 94.

**PASSO 1: Cortar o bite JE 95 conforme medida de corte determinada.**

STEP 1: Cut the JE 95 bead according to the determined cutting measure.

ÉTAPE 1: Couper le parclose JE 95 selon la mesure de coupe déterminée.

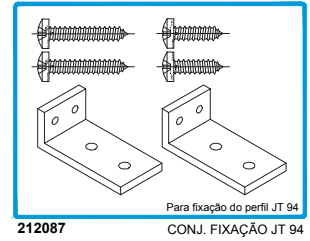
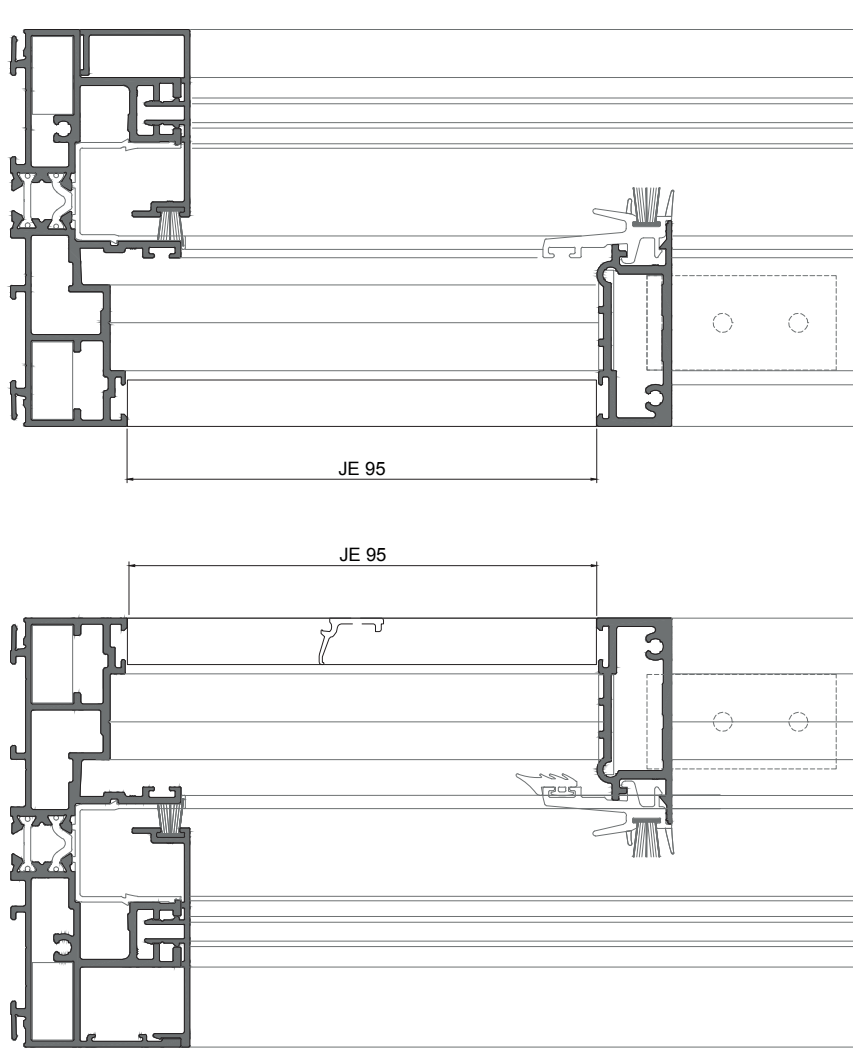

**PASSO 2: Colocação do Conj. Fixação JT 94 no perfil JT 94.**

STEP 2: JT 94 Fixing Kit placing into the JT 94 profile.

ÉTAPE 2: Placement du Kit de Fixation JT 94 sur le profilé JT 94.

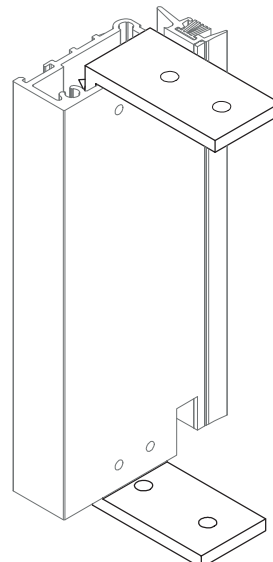
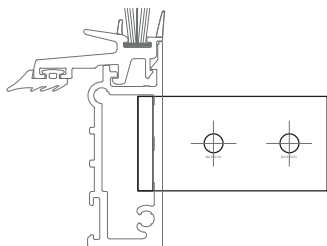

**MONTAGEM DOS PERFIS ARO FIXO PARA TIPOLOGIAS FIXAS (CORTE 45°)**

FIXED TYPOLOGIES FIXED FRAME PROFILES ASSEMBLY (45° CUT)

ASSEMBLAGE DES PROFILÉS DORMANT POUR TYPOLOGIES FIXES (COUPE 45°)

**8 - Aplicação do perfil JT 94 com o Conj. Fixação JT 94.**

JT 94 application using the JT 94 Fixing Kit application.

Application du profilé JT 94 en utilisant le Kit de Fixation JT 94.

**PASSO 3: Colocação do bite JE 95 e do perfil montante no aro fixo, com as cantoneiras no interior do perfil (por fixar).**

STEP 3: JE 95 and mullion profile application to the fixed frame, with the angles inside the profile (to be fixed).

ÉTAPE 3: Application du parciose JE 95 et du profilé de meneau sur le cadre dormant, avec les angles à l'intérieur du profilé (à fixer).

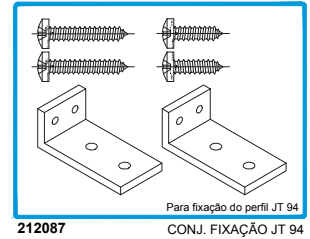

**PASSO 4: Fixação do Conj. Fixação JT 94.**

STEP 4: JT 94 Fixing Kit fixation into the JT 94 profile.

ÉTAPE 4: Fixation du Kit de Fixation JT 94 sur le profilé JT 94.

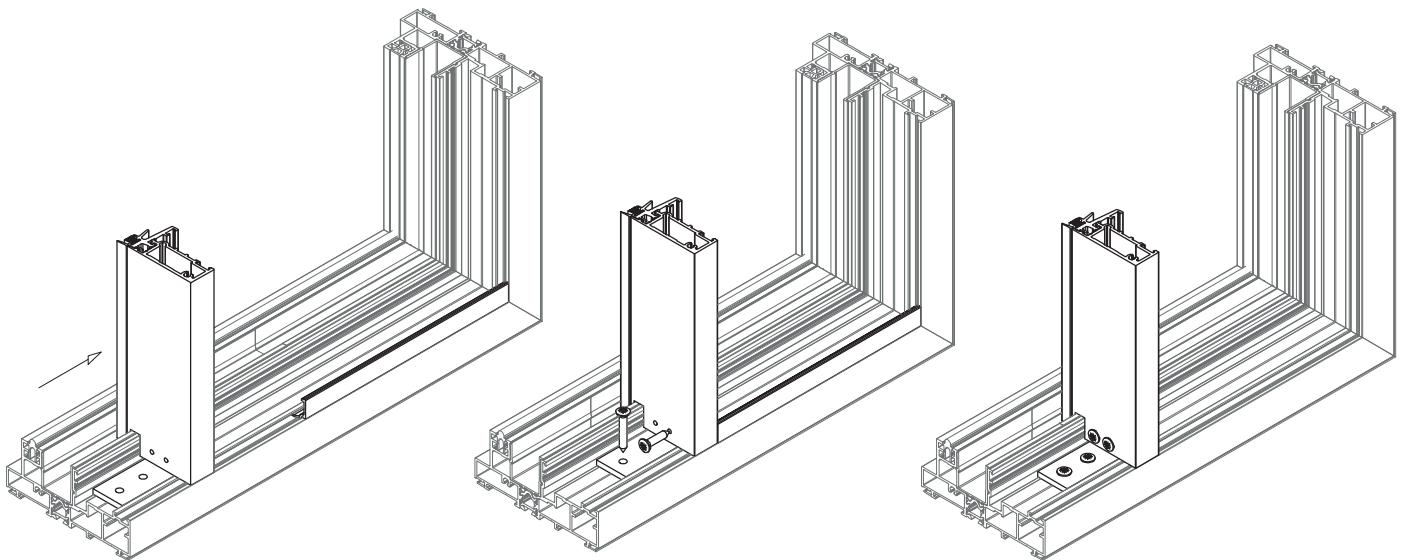
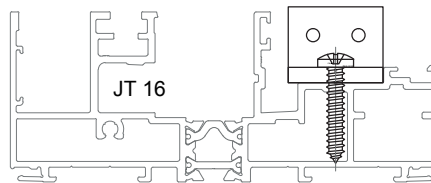
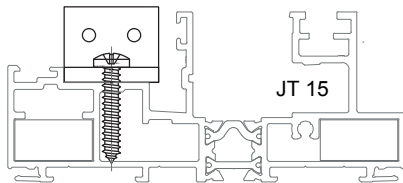

**PASSO 5: Aplicar silicone na zona de contacto entre os perfis aro fixo e montante, em cima e em baixo, antes de colocar as capas.**

STEP 5: Silicone application in the contact area between the fixed frame et mullion profile, at the top and bottom, before placing the covers.

ÉTAPE 5: Application de silicone dans la zone de contact entre les dormants et le profilé meneau, en haut et en bas, avant la pose des profilés de capot.

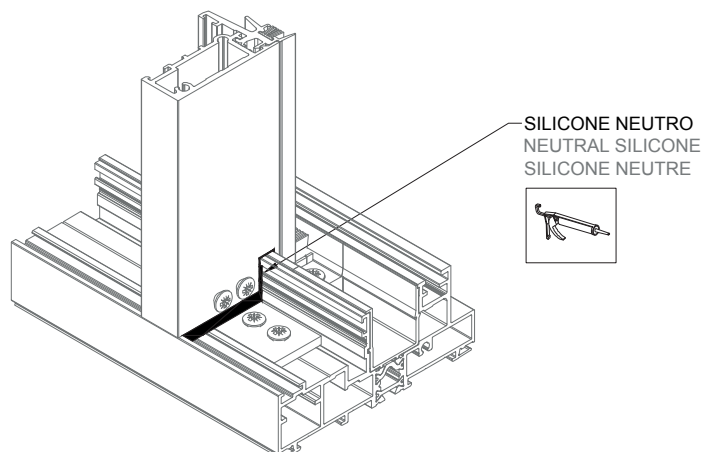

**MONTAGEM DOS PERFIS ARO FIXO PARA TIPOLOGIAS FIXAS (CORTE 45°)**  
FIXED TYPOLOGIES FIXED FRAME PROFILES ASSEMBLY (45° CUT)  
ASSEMBLAGE DES PROFILÉS DORMANT POUR TYPOLOGIES FIXES (COUPE 45°)

8 - Aplicação do perfil JT 94 com o Conj. Fixação JT 94.  
JT 94 application using the JT 94 Fixing Kit application.  
Application du profilé JT 94 en utilisant le Kit de Fixation JT 94.

**PASSO 6: Posicionamento e fixação dos corta-ventos.**  
**STEP 6: Positioning and fixing the central gaskets.**  
**ÉTAPE 6: Positionnement et fixation des joints d'étanchéité..**

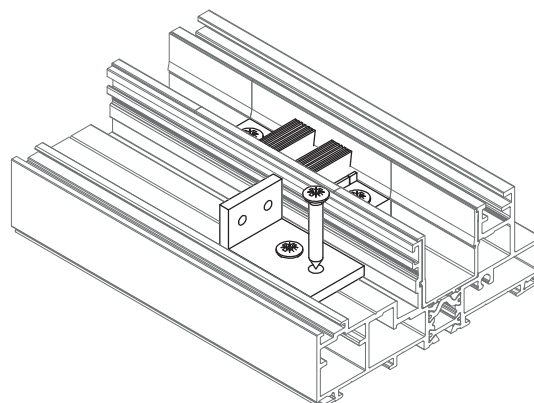
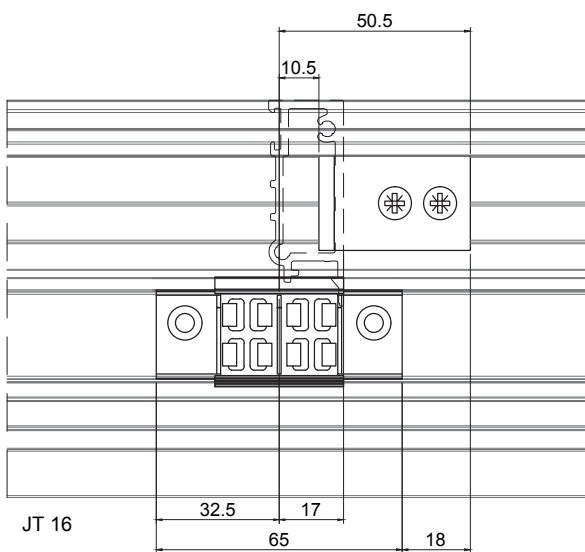
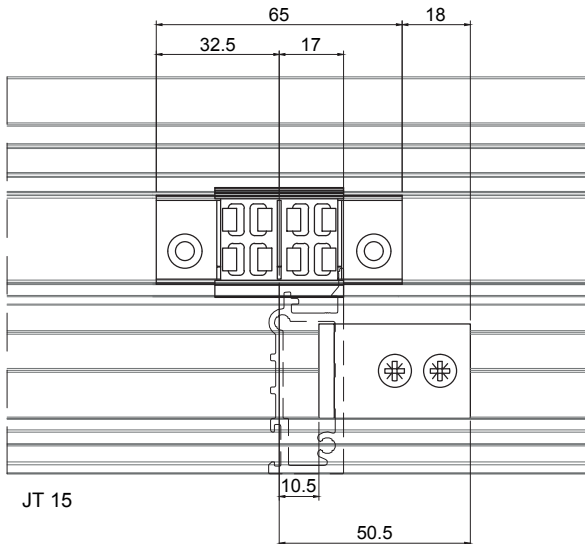
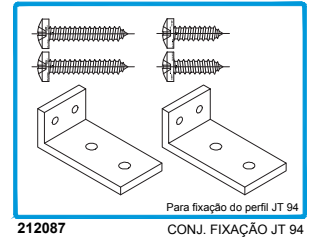

**MONTAGEM DOS PERFIS ARO FIXO PARA TIPOLOGIAS FIXAS (CORTE 45°)**

FIXED TYPOLOGIES FIXED FRAME PROFILES ASSEMBLY (45° CUT)

ASSEMBLAGE DES PROFILÉS DORMANT POUR TYPOLOGIES FIXES (COUPE 45°)

**9 - Aplicação do perfil JT 94 através de parafusos - APLICAÇÃO ALTERNATIVA.**

JT 94 application using the screws - **ALTERNATIVE APPLICATION.**

Application du profilé JT 94 en utilisant des vis - **APPLICATION ALTERNATIVE.**

**PASSO 1: Cortar o bite JE 95 conforme medida de corte determinada.**

**STEP 1: Cut the JE 95 bead according to the determined cutting measure.**

**ÉTAPE 1: Couper le parclose JE 95 selon la mesure de coupe déterminée.**

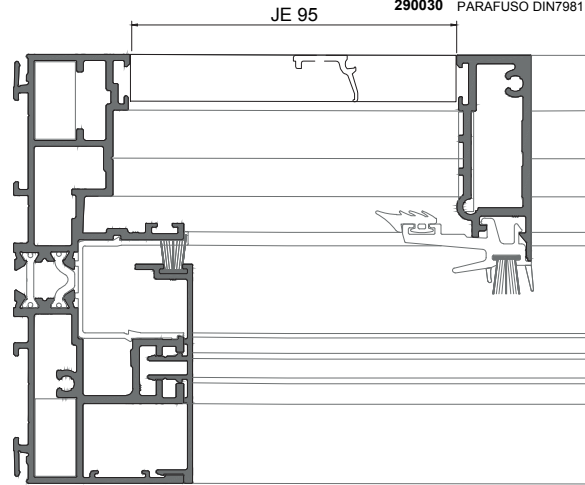
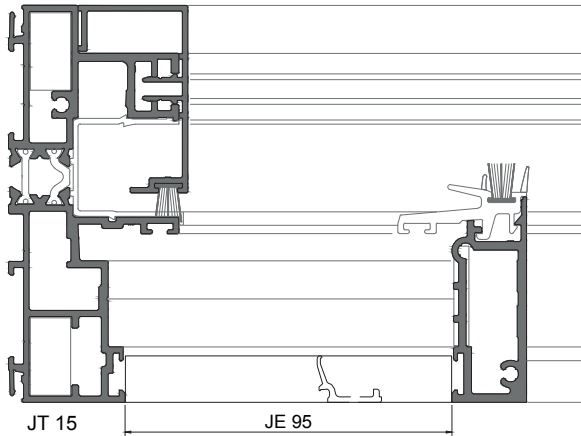
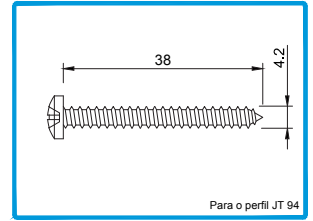

**PASSO 2: Determinar a posição dos parafusos e maquinar o aro fixo superior e inferior.**

**STEP 2: Determine the position of the screws and machine the upper and lower fixed frame.**

**ÉTAPE 2: Déterminer la position des vis et usiner le cadre fixe supérieur et inférieur.**

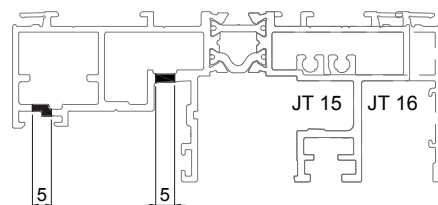
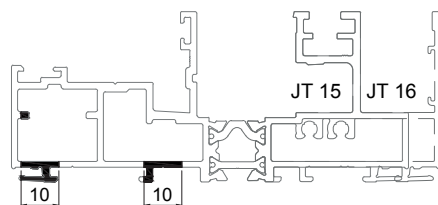
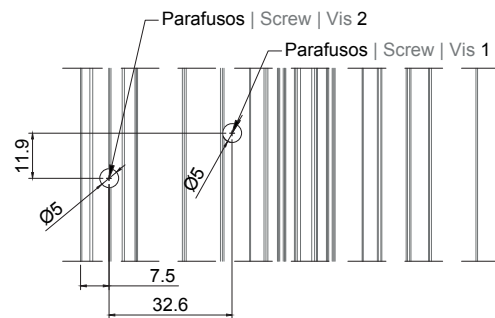
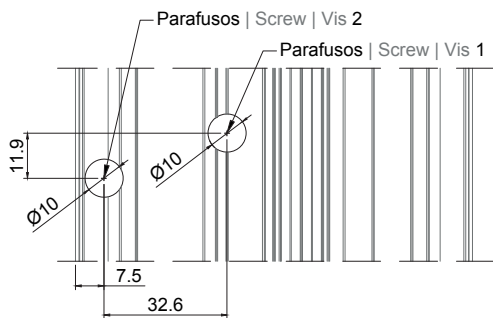
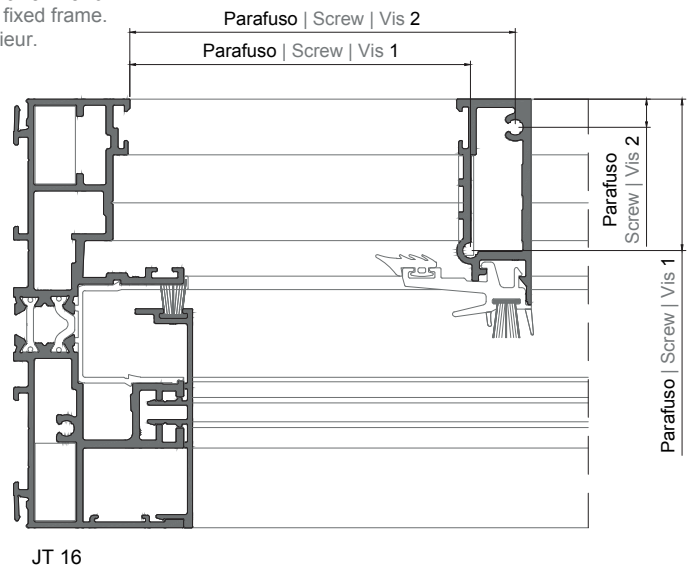
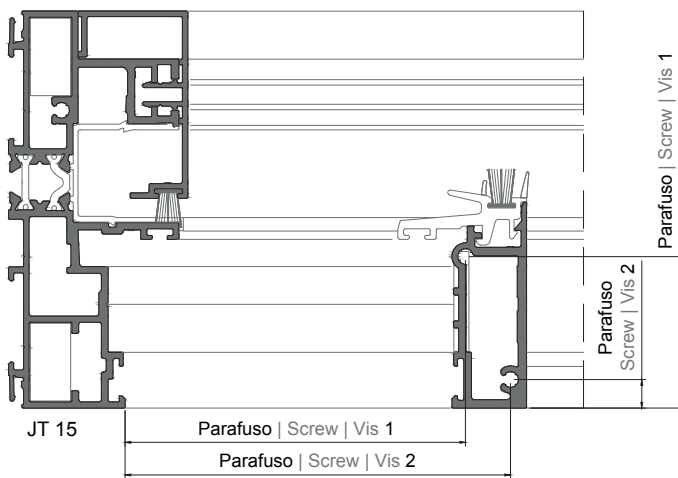

**MONTAGEM DOS PERFIS ARO FIXO PARA TIPOLOGIAS FIXAS (CORTE 45°)**

FIXED TYPOLOGIES FIXED FRAME PROFILES ASSEMBLY (45° CUT)

ASSEMBLAGE DES PROFILÉS DORMANT POUR TYPOLOGIES FIXES (COUPE 45°)

**9 - Aplicação do perfil JT 94 através de parafusos - APLICAÇÃO ALTERNATIVA.**

JT 94 application using the screws - **ALTERNATIVE APPLICATION.**

Application du profilé JT 94 en utilisant des vis - **APPLICATION ALTERNATIVE.**

**PASSO 3: Colocação do bite JE 95 e do perfil montante no aro fixo.**

**STEP 3: JE 95 and mullion profile application to the fixed frame.**

**ÉTAPE 3: Application du parclose JE 95 et du profilé de meneau sur le cadre dormant.**

**PASSO 4: Fixação do perfil usando os parafusos.**

**STEP 4: Profile fixing using screws.**

**ÉTAPE 4: Fixation du profilé à l'aide de vis.**

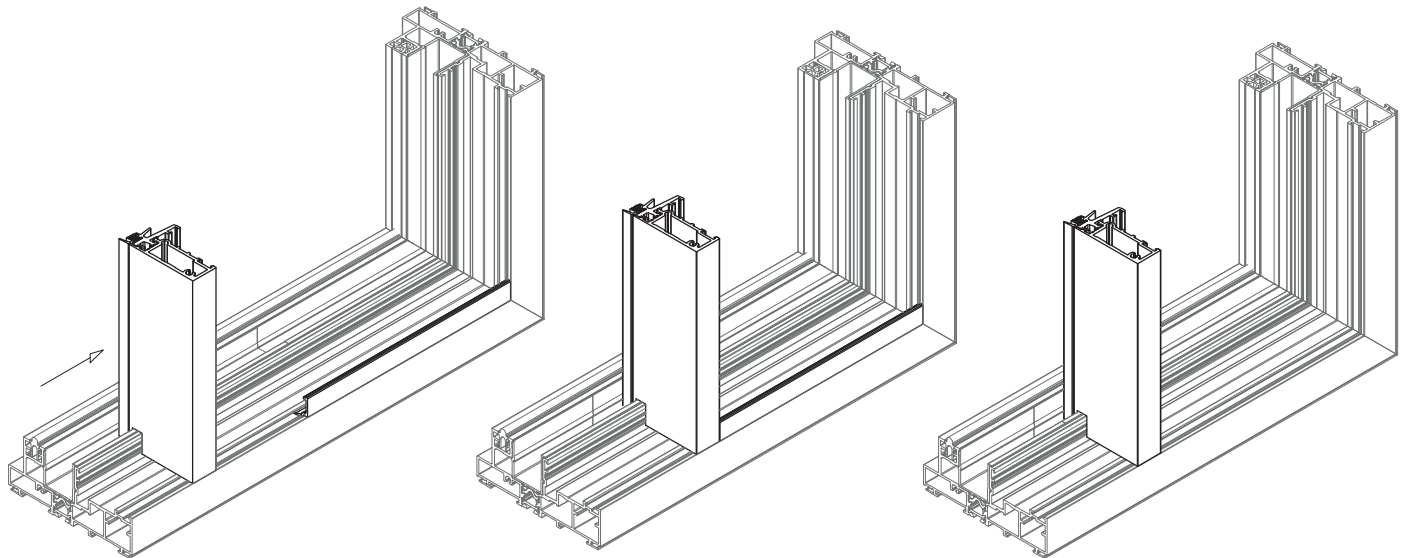
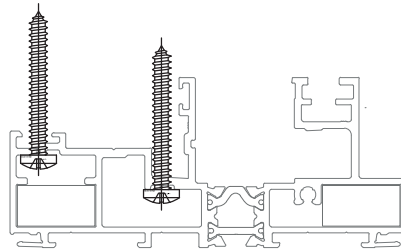
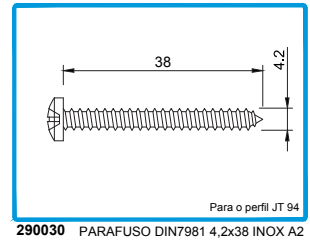

**PASSO 5: Aplicar silicone na zona de contacto entre os perfis aro fixo e montante, em cima e em baixo, antes de colocar as capas.**

**STEP 5: Silicone application in the contact area between the fixed frame and mullion profile, at the top and bottom, before placing the covers.**

**ÉTAPE 5: Application de silicone dans la zone de contact entre les dormants et le profilé meneau, en haut et en bas, avant la pose des profilés de capot.**

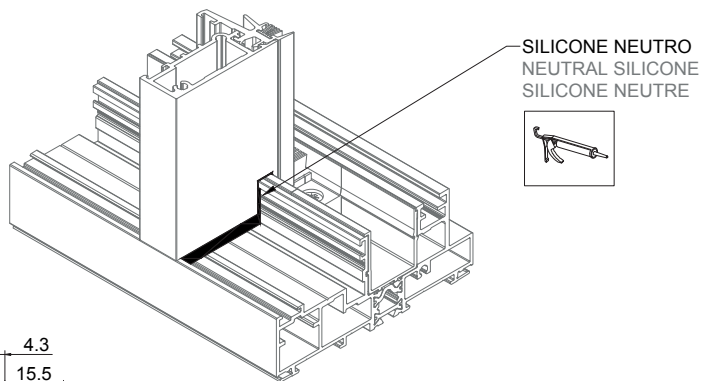

**PASSO 6: Posicionamento e fixação dos corta-ventos.**

**STEP 6: Positioning and fixing the central gaskets.**

**ÉTAPE 6: Positionnement et fixation des joints d'étanchéité..**

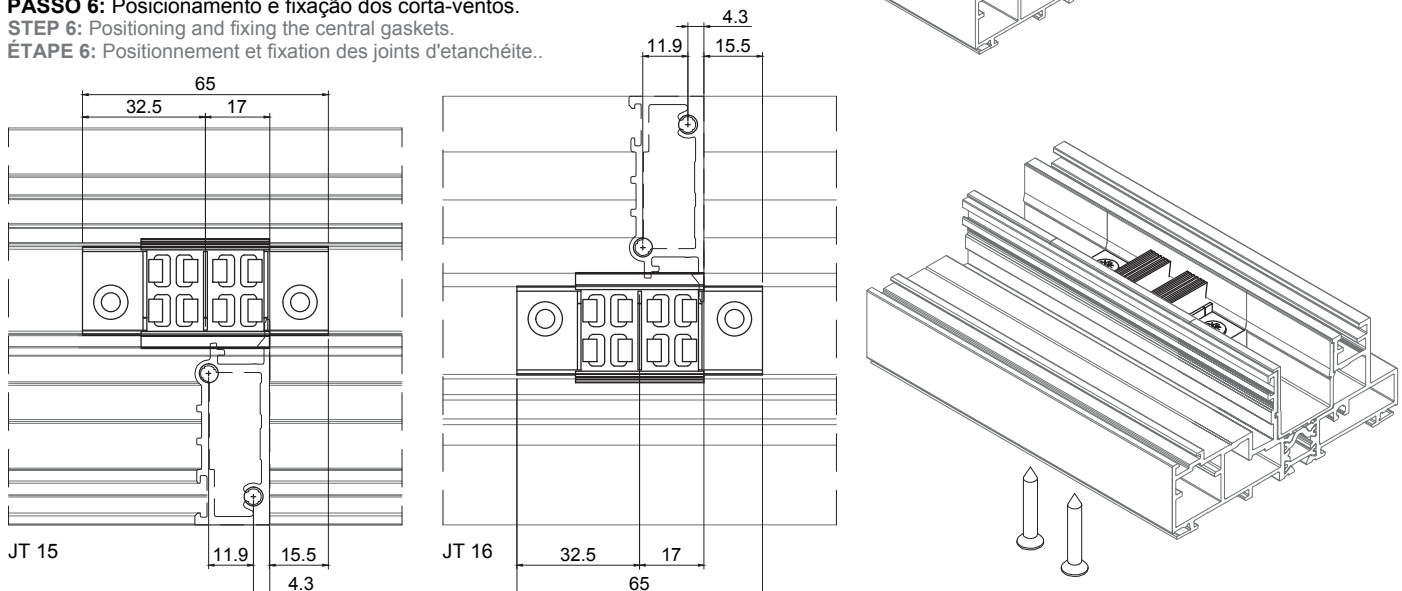



**MONTAGEM DOS PERFIS ARO FIXO PARA TIPOLOGIAS FIXAS (CORTE 45°)**

FIXED TYPOLOGIES FIXED FRAME PROFILES ASSEMBLY (45° CUT)

ASSEMBLAGE DES PROFILÉS DORMANT POUR TYPOLOGIES FIXES (COUPE 45°)

**10 - Aplicação da junta tapa canal 2116 nos aros fixos.**

2116 channel cover joint applying in fixed frames.

Application de la joint de couverture du canal 2116 sur les cadres dormants.

Esta junta deverá ser aplicada no aro fixo, na padieira e nas laterais. Nas zonas onde se localizarão os contra-fechos, a junta deverá ser interrompida.

This joint must be applied in the fixed frame, in the lintel and the laterals. In the zones where the counter-locks will be located, the joint must be interrupted.

Ce joint doit être appliqué sur le cadre dormant, le linteau et les côtés. Dans les zones où seront situées les contre-serrures, le joint doit être interrompu.

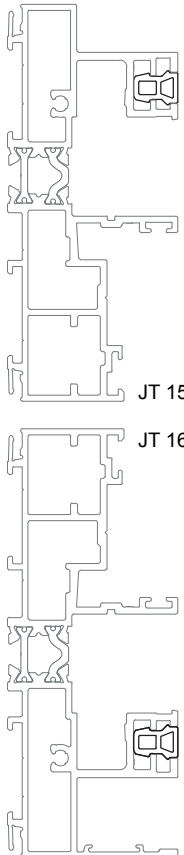
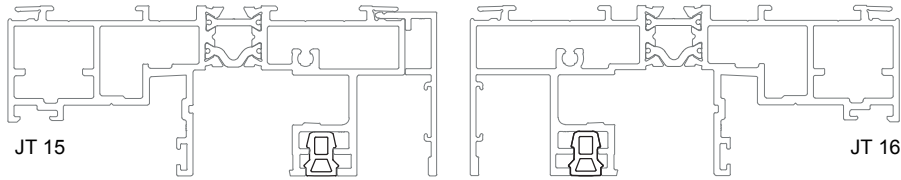
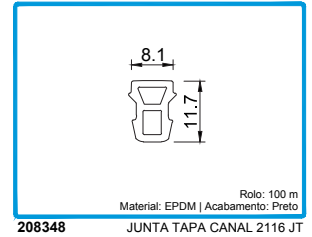

**Zona de localização do contra-fecho**  
(a esta folga dever-se-à adicionar a altura de funcionamento do gancho, no caso da ferragem multiponto SOT)

**Locking plate location zone**  
(to this gap must be added the working height of the hook, in the case of SOT multipoint hardware)

**Zone d'emplacement de contre-verrouillage**  
(la hauteur du crochet doit être ajoutée à cet espace, dans le cas du matériel multipoint SOT)

**IMPORTANTE | IMPORTANT | IMPORTANT:**  
A zona de interrupção da junta deverá ser suficiente para permitir os movimentos do fecho multiponto SOT.  
The joint interruption zone must be sufficient to allow the movements of the SOT multipoint lock.  
La zone d'interruption de la joint doit être suffisante pour permettre les mouvements de la serrure multipoint SOT.

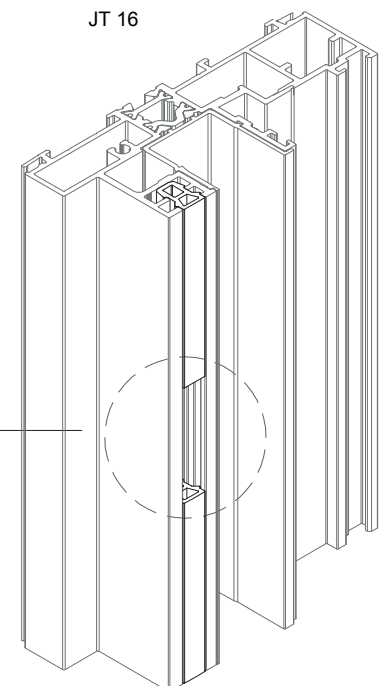

**11 - Corte e aplicação do perfil guia JT87 nos aros fixos.**

Cutting and applying of JT87 rail profile in fixed frames.  
Couper et appliquer le profilé de guide JT87 sur les cadres dormants.

O perfil JT87 deverá ser aplicado nas soleiras, conforme esquemas abaixo:

The JT87 profile must be applied in the sills, according to the schemes below:  
Le profilé JT87 doit être appliqué aux seuils, selon les schémas ci-dessous:

**NOTA | NOTE | REMARQUE:**  
Em perfis anodizados, a guia JT87 deverá ser aplicada com um cordão de silicone neutro.  
On anodised profiles the JT87 guide should be applied with a neutral silicone cord.  
Sur les profis anodisés, le guide JT87 doit être appliqué avec un cordon de silicone neutre.

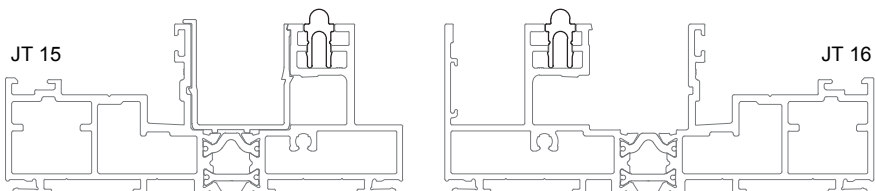
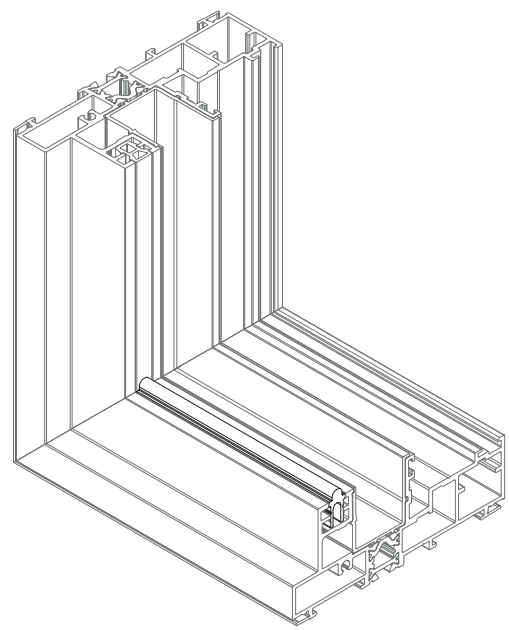



**MONTAGEM DOS PERFIS ARO FIXO PARA TIPOLOGIAS FIXAS (CORTE 45°)**

FIXED TYPOLOGIES FIXED FRAME PROFILES ASSEMBLY (45° CUT)

ASSEMBLAGE DES PROFILÉS DORMANT POUR TYPOLOGIES FIXES (COUPE 45°)

**12 - Aplicação da pelúcia 7x10 Tri-Fin nos perfis de capa JT89 e JT91.**

7x10 Tri-Fin pile seal application to the JT89 and JT91 cover profiles.

Application de la joint brosse 7x10 Tri-Fin sur le profilés de capot JT89 et JT91.

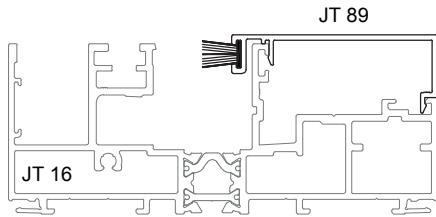
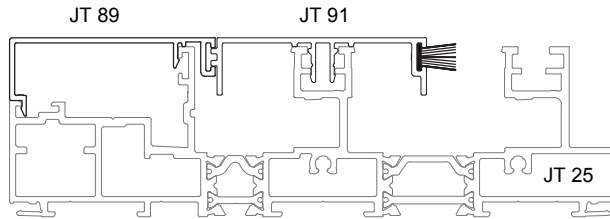
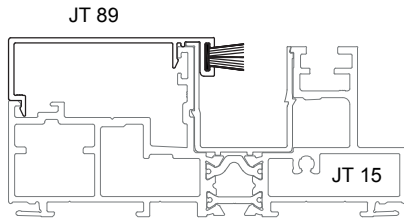
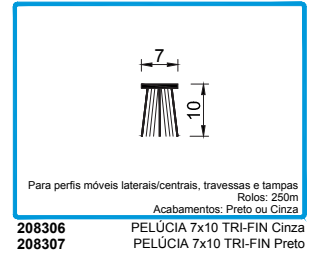

**IMPORTANTE | IMPORTANT | IMPORTANT:**  
Colocar a folha de correr antes de aplicar as capas.  
Place the sliding sash before applying the covers.  
Placer la feuille de glissement avant d'appliquer les capots.

**PASSO | STEP | ÉTAPE 1:**

Colocar os perfis verticais.

Place the vertical profiles.

Placer les profilés verticaux.

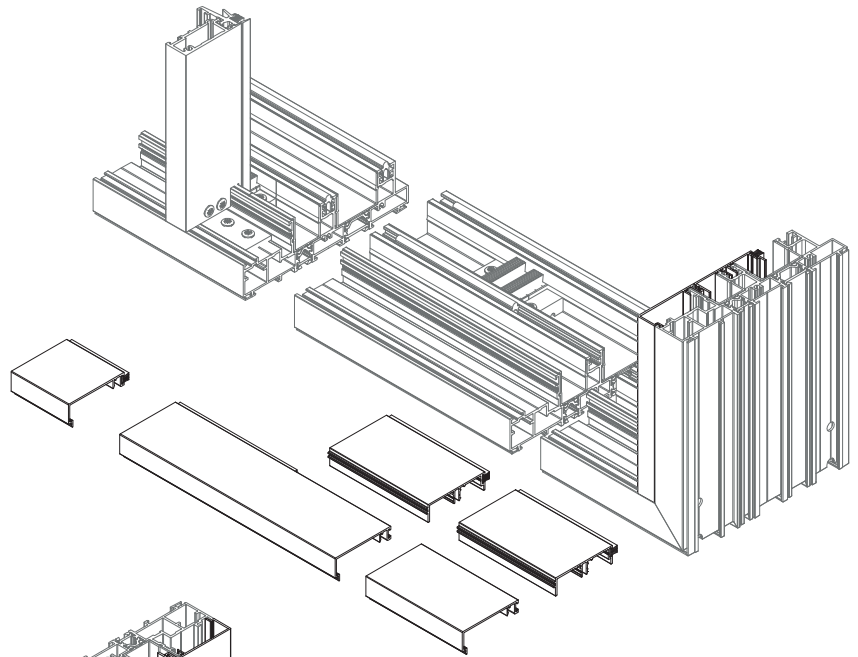
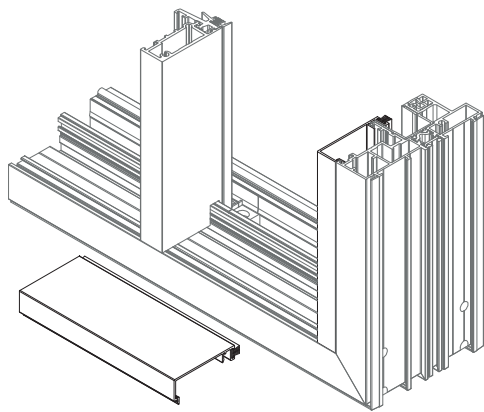

**PASSO | STEP | ÉTAPE 2:**

Colocar os perfis horizontais.

Place the horizontal profiles.

Placer les profilés horizontaux.

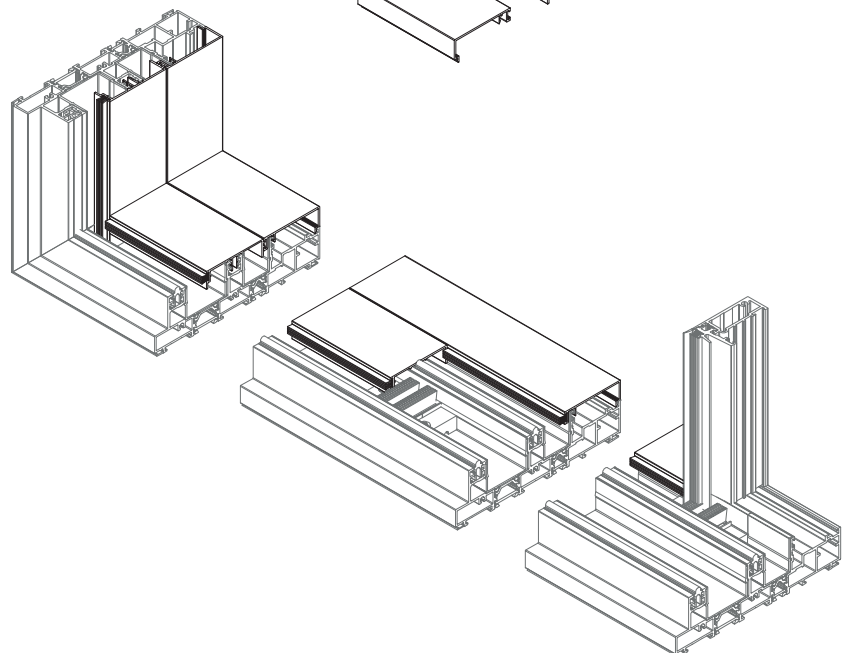
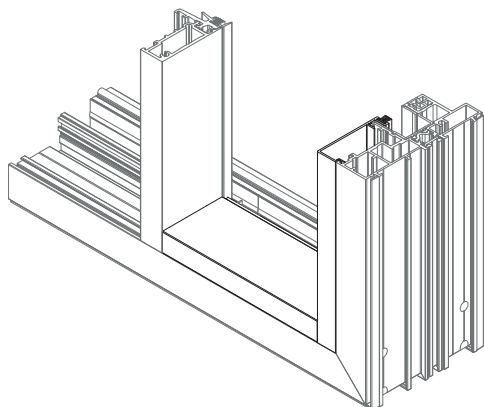

**MONTAGEM DOS PERFIS ARO FIXO PARA TIPOLOGIAS FIXAS (CORTE 45°)**

FIXED TYPOLOGIES FIXED FRAME PROFILES ASSEMBLY (45° CUT)

ASSEMBLAGE DES PROFILÉS DORMANT POUR TYPOLOGIES FIXES (COUPE 45°)

**13 - Aplicação do limitador de abertura nos perfis JT 15, JT 16 e JT 25.**

Opening limiter application on the JT 15, JT 16 and JT 25 profiles.

Application du limiteur d'ouverture sur les profilés JT 15, JT 16 et JT 25 .

A posição do limitador de abertura no rail, depende da largura da folha móvel em relação à folha fixa.

The position of the opening limiter on the rail depends on the width of the mobile sash in relation to the fixed sash.

La position du limiteur d'ouverture sur le rail dépend de la largeur de la vantail ouvrant par rapport à la vantail fixe.

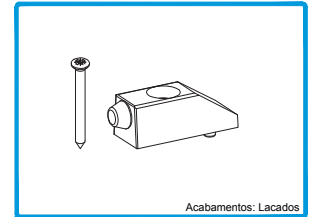

228107

Acabamentos: Lacados  
LIMITADOR ABERTURA  
PQ SERIE CORRER

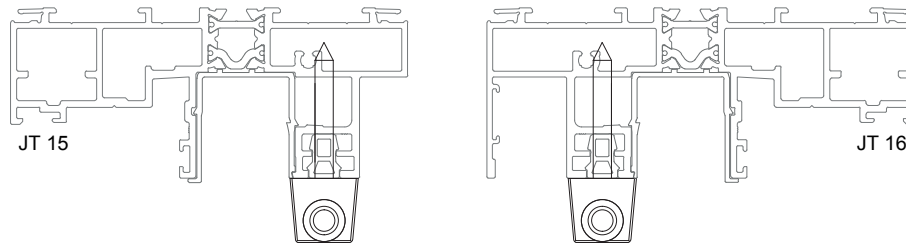

JT 15

JT 16

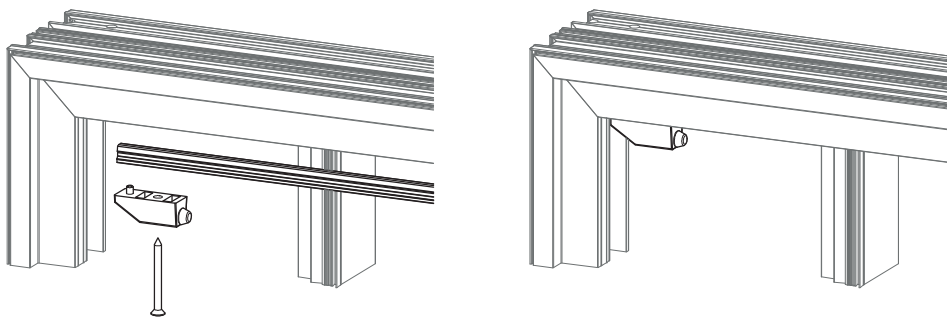

**13.1 - Tipologias 1 folha móvel + fixo.**

1 sliding sash + fix typologies.

Typologies 1 vantail coulissant + fixe.

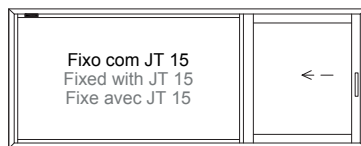

Fixo com JT 15  
Fixed with JT 15  
Fixe avec JT 15

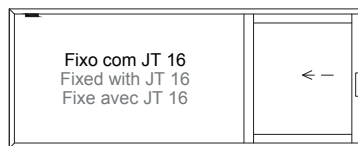

Fixo com JT 16  
Fixed with JT 16  
Fixe avec JT 16

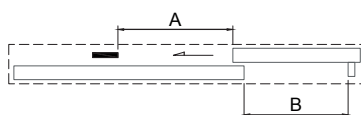

Opcional | Optional | Facultatif

**EXEMPLO**

EXAMPLE | EXEMPLE:

A distância de A tem de ser menor que a distância de B.

The distance from A must be less than the distance from B.

La distance de A doit être inférieure à la distance de B.

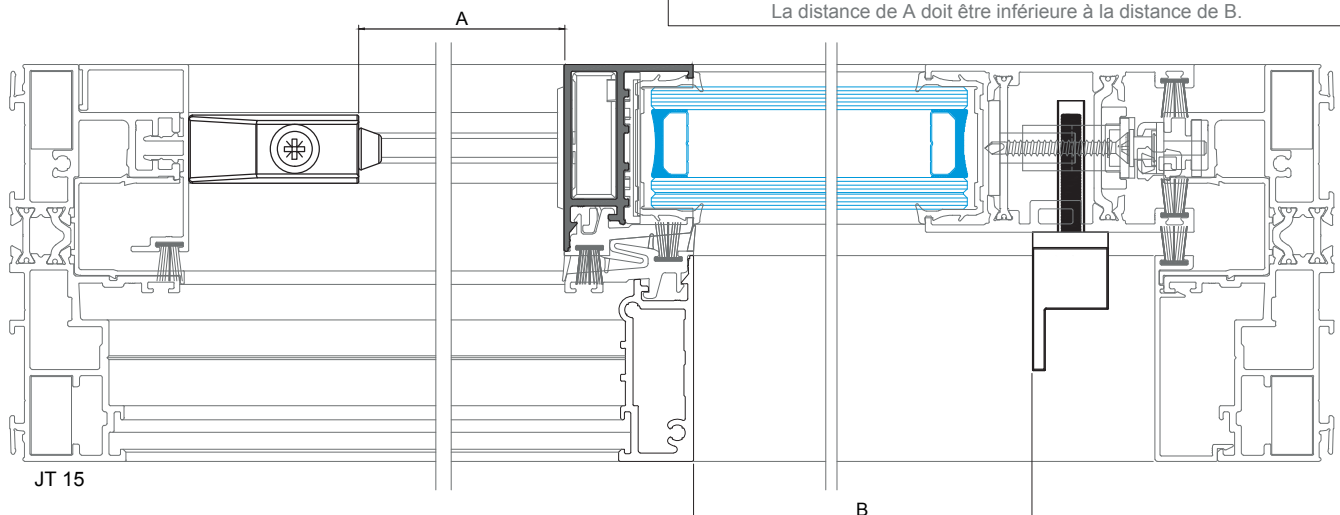

JT 15

B

**MONTAGEM DOS PERFIS ARO FIXO PARA TIPOLOGIAS FIXAS (CORTE 45°)**

FIXED TYPOLOGIES FIXED FRAME PROFILES ASSEMBLY (45° CUT)

ASSEMBLAGE DES PROFILÉS DORMANT POUR TYPOLOGIES FIXES (COUPE 45°)

**13 - Aplicação do limitador de abertura nos perfis JT 15 e JT 25.**

Opening limiter application on the JT 15 and JT 25 profiles.  
Application du limiteur d'ouverture sur les profilés JT 15 et JT 25.

**13.2.1 - Tipologias 2 folhas móveis + fixo, com JT 15 e JT 16.**

2 sliding sashes + fix typologies, with JT 15 and JT 16.  
Typologies 2 vantaux coulissants + fixe, avec JT 15 et JT 16.

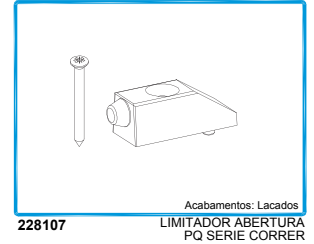
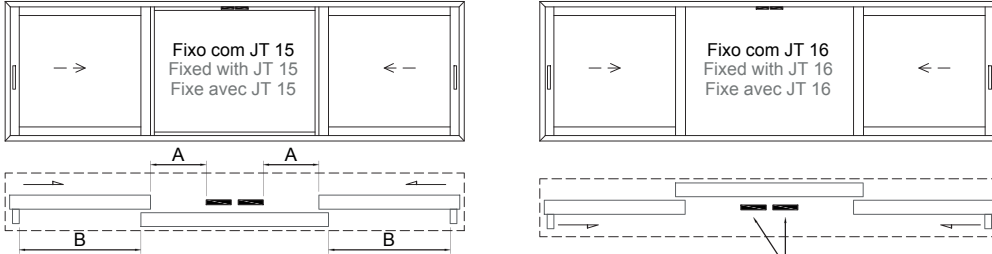

A distância de A tem de ser menor que a distância de B.  
The distance from A must be less than the distance from B.  
La distance de A doit être inférieure à la distance de B.

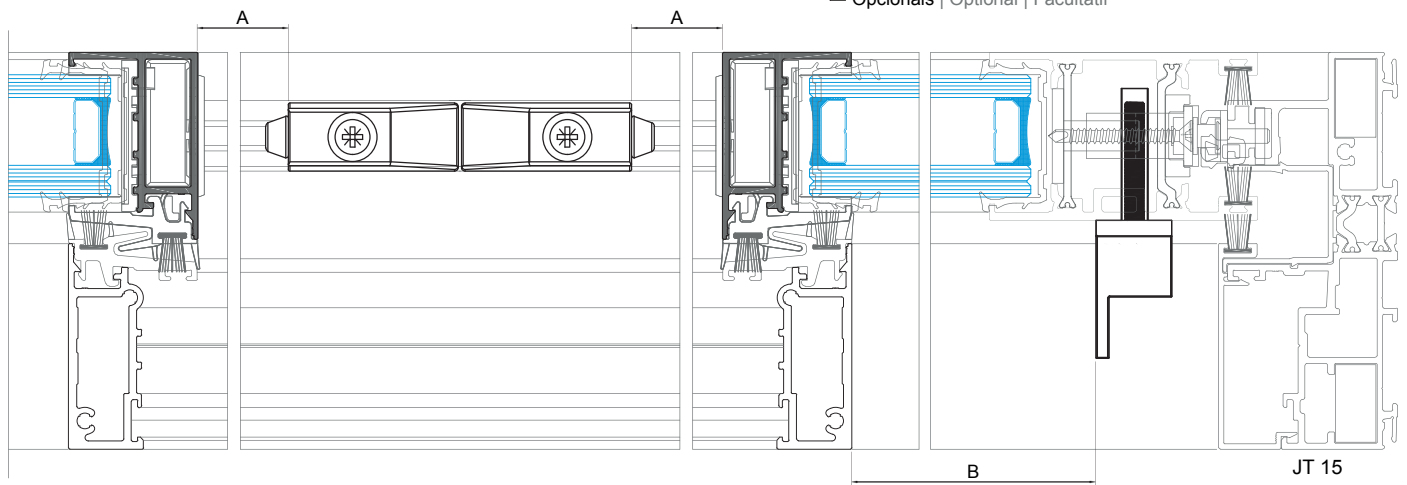

**13.2.2 - Tipologias 2 folhas móveis + fixo, com JT 25.**

2 sliding sashes + fix typologies, with JT 25.  
Typologies 2 vantaux coulissants + fixe, avec JT 25.

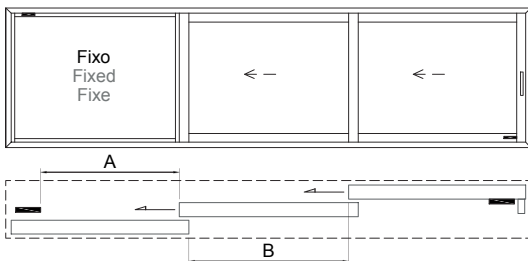

A distância A tem de ser menor que a distância B.  
The distance A must be less than the distance B.  
La distance A doit être inférieure à la distance B.

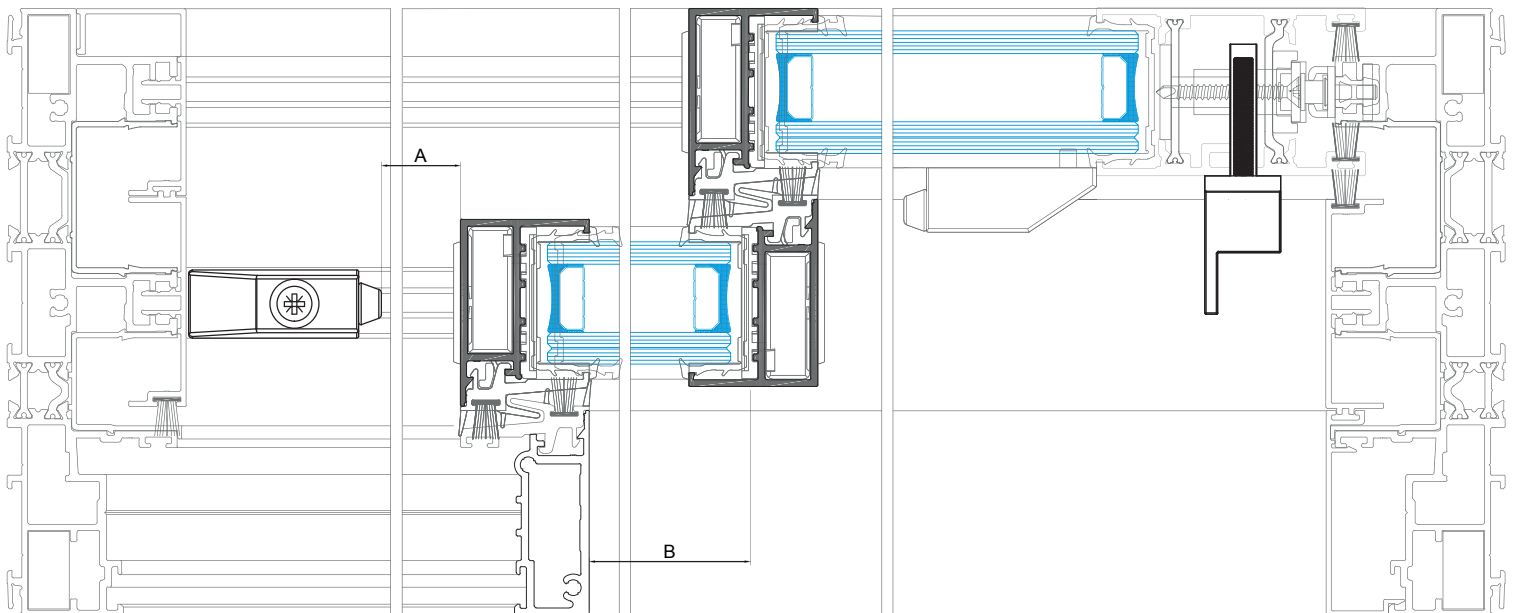

**MONTAGEM DOS PERFIS ARO FIXO PARA TIPOLOGIAS FIXAS (CORTE 45°)**

FIXED TYPOLOGIES FIXED FRAME PROFILES ASSEMBLY (45° CUT)

ASSEMBLAGE DES PROFILÉS DORMANT POUR TYPOLOGIES FIXES (COUPE 45°)

**14 - Assemblagem do vidro.**

Glass assembly.

Assemblage du verre.

**14.1 - Aplicação do vedante no perfil central PVC.**

Joint application on the central PVC profile.

Application de la joint dans le profilé central PVC.

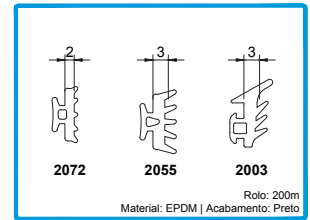
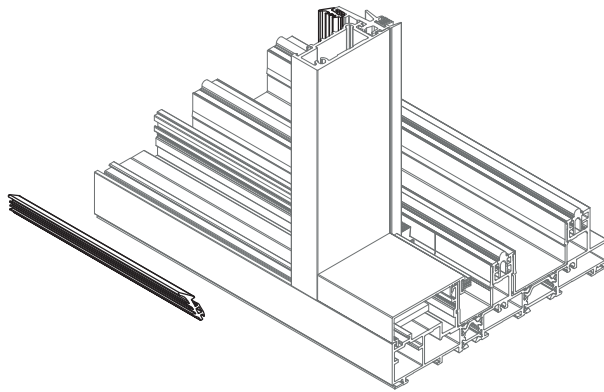

208224 JUNTA VD 2072  
208289 JUNTA DE BATEnte 2055  
208350 JUNTA DE VEDAÇÃO EXT. 2003

**14.2 - Preenchimento do canal do bite inferior com silicone e aparafusamento do perfil pré-furado.**

Filling the lower bead channel with silicone and screwing the pre-drilled profile.

Remplir le canal du parciose inférieur avec du silicone et visser le profilé pré-percé.

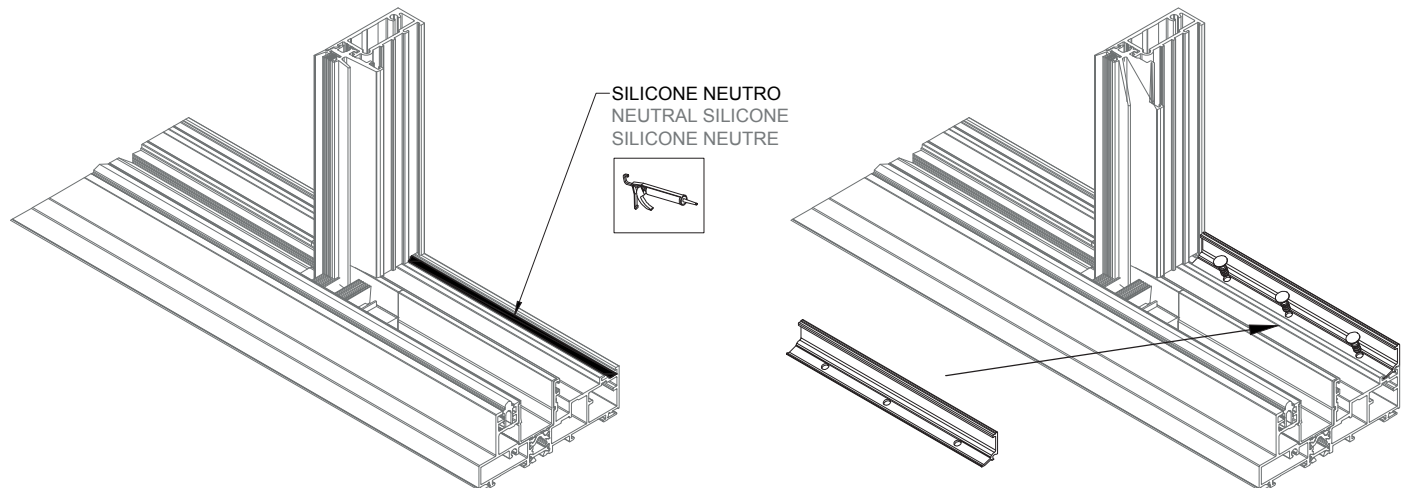
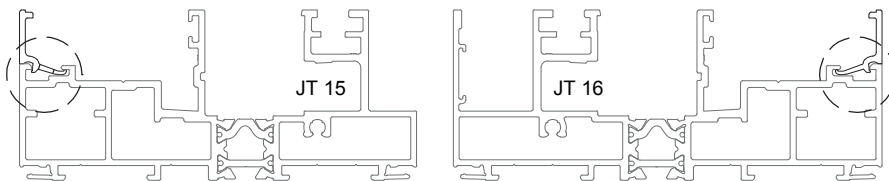

**MONTAGEM DOS PERFIS ARO FIXO PARA TIPOLOGIAS FIXAS (CORTE 45°)**  
FIXED TYPOLOGIES FIXED FRAME PROFILES ASSEMBLY (45° CUT)  
ASSEMBLAGE DES PROFILÉS DORMANT POUR TYPOLOGIES FIXES (COUPE 45°)

**14 - Assemblagem do vidro.**  
Glass assembly.  
Assemblage du verre.

**14.3 - Colocação do vidro e dos restantes bites (primeiro os horizontais e depois os verticais).**  
Placement of the glass and the remaining beads (first the horizontal and then the vertical ones).  
Placement du verre et des parclozes restants (d'abord les horizontaux et ensuite les verticaux).

**SILICONE NEUTRO**  
NEUTRAL SILICONE  
SILICONE NEUTRE

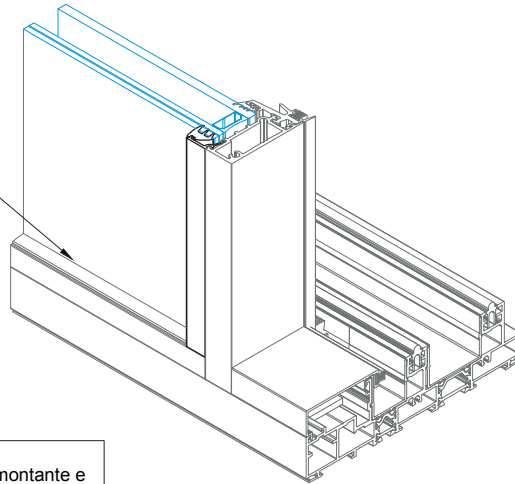

**Nos perfis JT 15, JT 16 e JT 25:**  
Recomenda-se a selagem inferior do perfil montante e das extremidades do bite inferior.  
In JT 15, JT 16 and JT 25 profiles:  
Bottom sealing of the riser profile and the ends of the bottom bead is recommended.  
**Dans les profilés JT 15, JT 16 et JT 25:**  
Il est recommandé de sceller le bas du profilé de la colonne montante et les extrémités du parcloze inférieur.

**No perfil JT 16:**  
Efetuar a colagem do bite superior com cola e veda previamente à colocação do vedante de cunha.  
In JT 25 and JT 25 profiles:  
Glue the upper bead with bond and seal before fitting the joint.  
**Dans les profilés JT 25 et JT 25:**  
Coller le parcloze supérieur avec de la mastic colle avant de poser le joint.

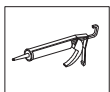

**COLA E VEDA**  
BOND AND SEAL  
MASTIC COLLE

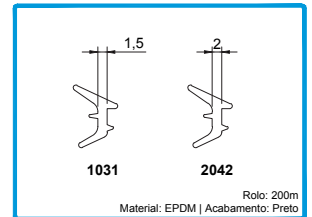
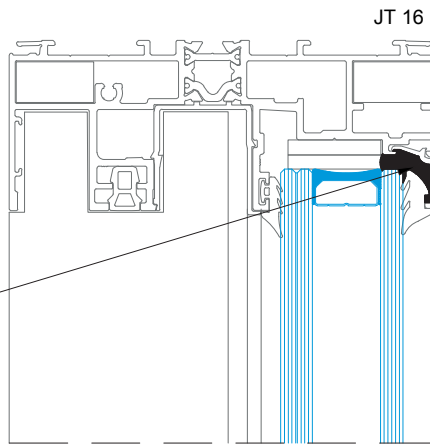

**208223**      JUNTA DE CUNHA 1031  
**208191**      JUNTA DE CUNHA 2042

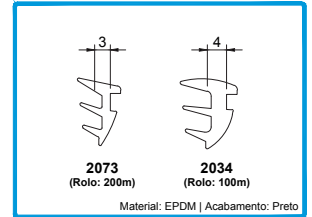

**208199**      JUNTA DE CUNHA 2073  
**208195**      JUNTA DE CUNHA 2034

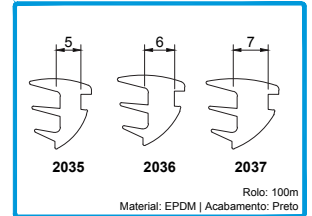

**208196**      JUNTA DE CUNHA 2035  
**208215**      JUNTA DE CUNHA 2036  
**208904**      JUNTA DE CUNHA 2037

**14.4 - Colocação do perfil de pingadeira JT 82.**  
Fitting the drip profile JT 82.  
Montage du larmier JT 82

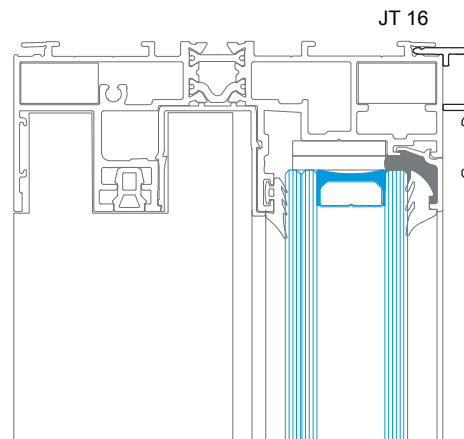
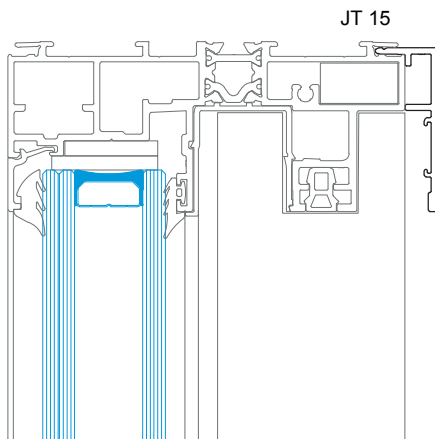

**MONTAGEM DOS PERFIS ARO FIXO COM SOLEIRA 30MM (CORTE 90°)**

FIXED FRAME PROFILES ASSEMBLY WITH 30MM SILL PROFILE (90° CUT)

ASSEMBLAGE DES PROFILÉS DORMANT AVEC SEUIL 30MM (COUPE 90°)

**1 - Colocação de goteiras nos aros fixos.**

Drips placing in fixed frames.

Placement des clapets sur les cadres dormants.

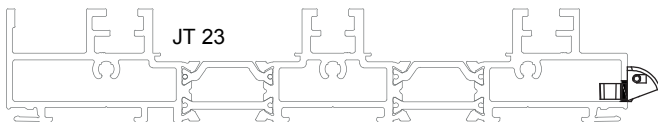
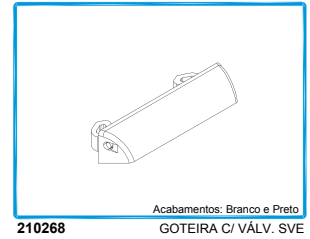
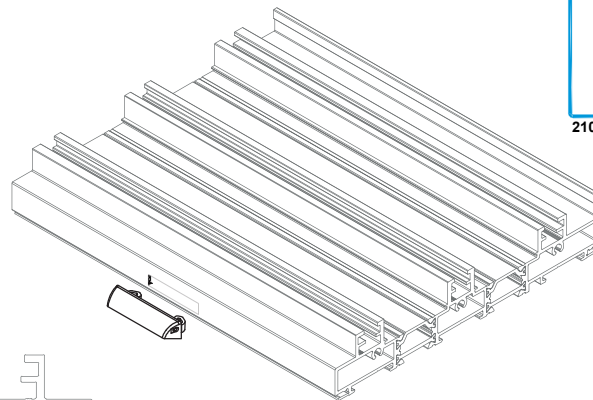
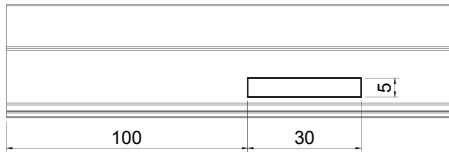

**2 - Colocação dos corta-ventos nos aros fixos.**

Central waterproofing pile seal placing in fixed frames.

Placement des brosses centrale d'étanchéité sur les cadres dormants.

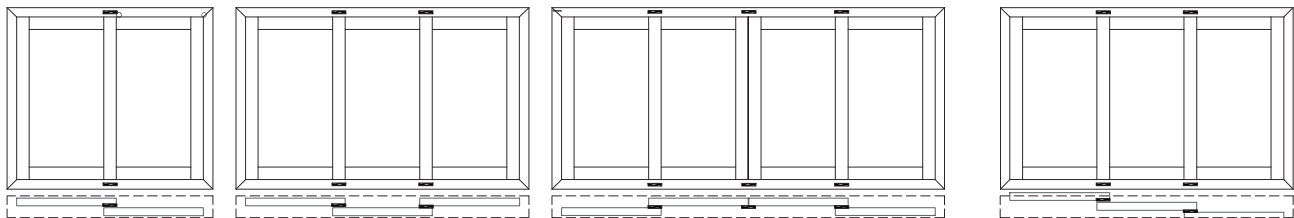
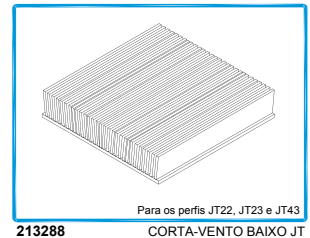
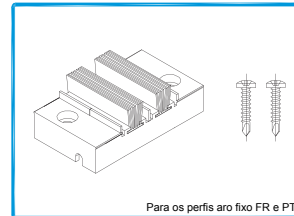

Aplicar os corta-ventos inferiores entre os perfis JE96, interrompendo-os em 35mm. **Os corta-ventos da padieira deverão ser colocados depois das folhas de correr já estarem aplicadas.**

Place the low central insulation gaskets between the JE96 profiles, interrupting it in 35mm. **The lintel central insulation gasket must be placed after the sliding sashes are already applied.**

Appliquer les brosses centrale d'étanchéité inférieures entre les profilés JE96, les arrête en 35mm. **Les brosses centrale d'étanchéité sur le linteau doivent être placés après que les feuilles coulissantes sont déjà appliquées.**

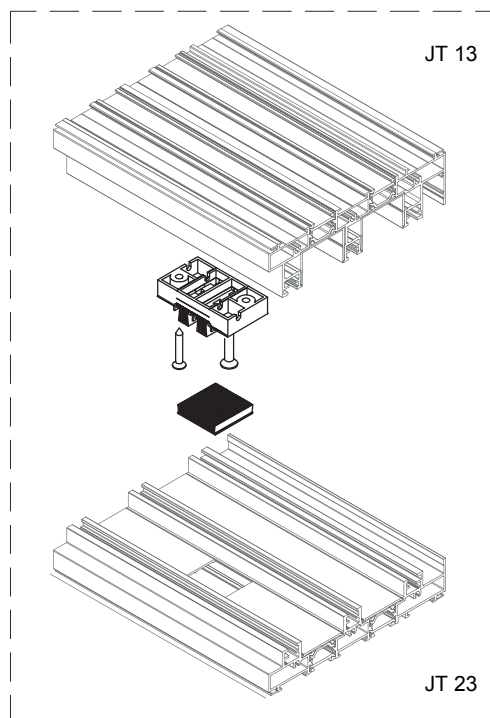
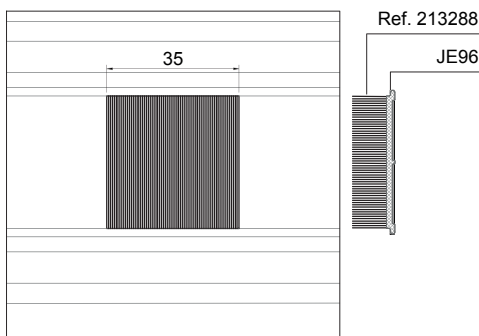



### MONTAGEM DOS PERFIS ARO FIXO COM SOLEIRA 30MM (CORTE 90°)

FIXED FRAME PROFILES ASSEMBLY WITH 30MM SILL PROFILE (90° CUT)

ASSEMBLAGE DES PROFILÉS DORMANT AVEC SEUIL 30MM (COUPE 90°)

#### 3 - Aplicação dos perfis JE96 e PVC U nos aros fixos.

JE96 e U PVC profiles application in fixed frames.

Application de profilés JE96 et PVC U sur les cadres dormant.

#### Passo | Step | Étape 1:

Aplicar os perfis JE96 nas ombreiras.

Place the JE96 profiles in jambs.

Appliquer les profilés JE96 sur les jambages.

#### Passo | Step | Étape 2:

Aplicar os perfis JE96 inferiores.

Place the bottom JE96 profiles.

Appliquer les profilés JE96 inférieures.

#### Passo | Step | Étape 3:

Aplicar as juntas adesivas nas extremidades dos perfis horizontais (em tipologias 4rail consultar a pág. seguinte).

Place the adhesive joints at the ends of the horizontal profiles (in 4rail typologies see the next page).

Placer les joints adhésifs aux extrémités des profilés horizontaux (en typologies de 4rails voir page suivante).

#### Passo | Step | Étape 4:

Fixar os perfis usando parafusos.

Fix the profiles using screws.

Fixer les profilés à l'aide de vis.

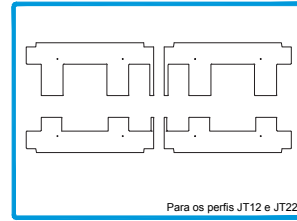

223105

KIT JUNTAS ADESIVAS Nº1 JT

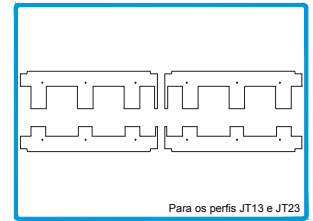

223106

KIT JUNTAS ADESIVAS Nº2 JT

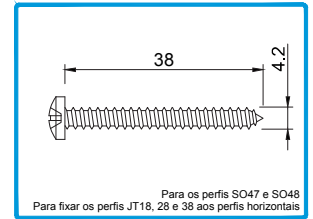

290030

Para os perfis SO47 e SO48  
Para fixar os perfis JT18, 28 e 38 aos perfis horizontais  
PARAFUSO DIN7981 4,2x38 INOX A2

#### IMPORTANTE | IMPORTANT | IMPORTANT:

O perfil PVC U superior só deverá ser aplicado depois de fechar o aro fixo.

The upper U PVC profile must be applied after the fixed frame is closed.

Le profilé en PVC U supérieur ne doit être appliqué qu'après la fermeture du cadre fixe.

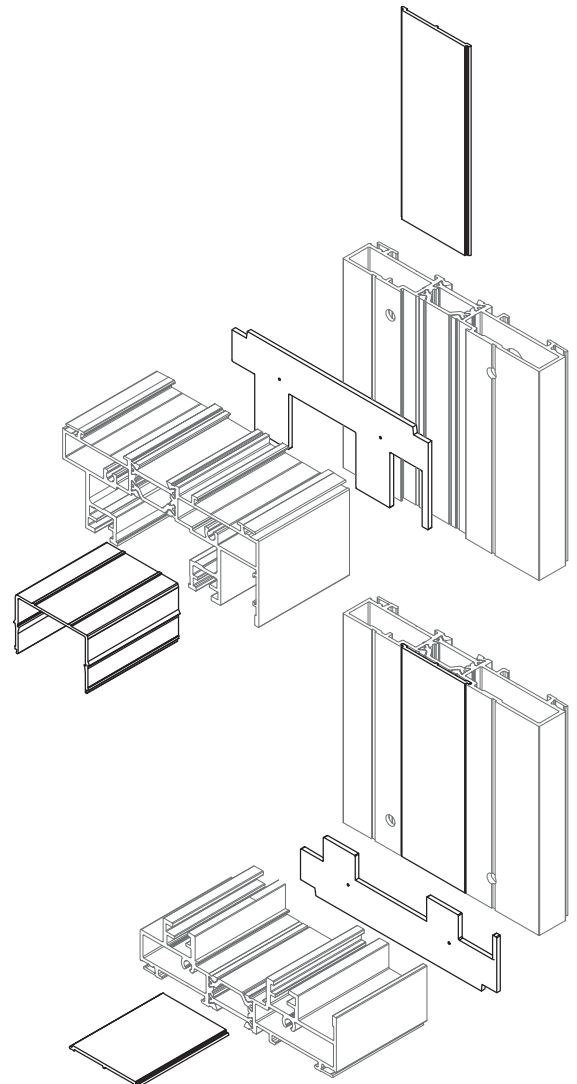
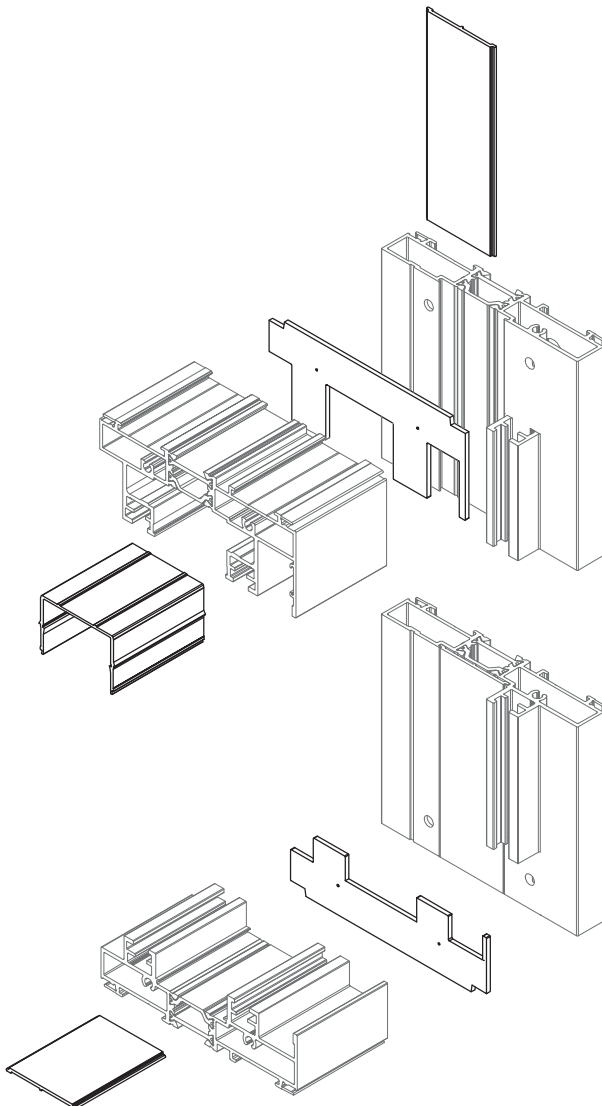



**MONTAGEM DOS PERFIS ARO FIXO COM SOLEIRA 30MM (CORTE 90°)**

FIXED FRAME PROFILES ASSEMBLY WITH 30MM SILL PROFILE (90° CUT)

ASSEMBLAGE DES PROFILÉS DORMANT AVEC SEUIL 30MM (COUPE 90°)

**3 - Aplicação dos perfis JE96 e PVC U nos aros fixos.**

JE96 e U PVC profiles application in fixed frames.

Application de profilés JE96 et PVC U sur les cadres dormant.

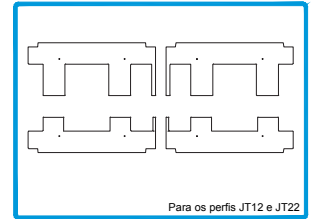
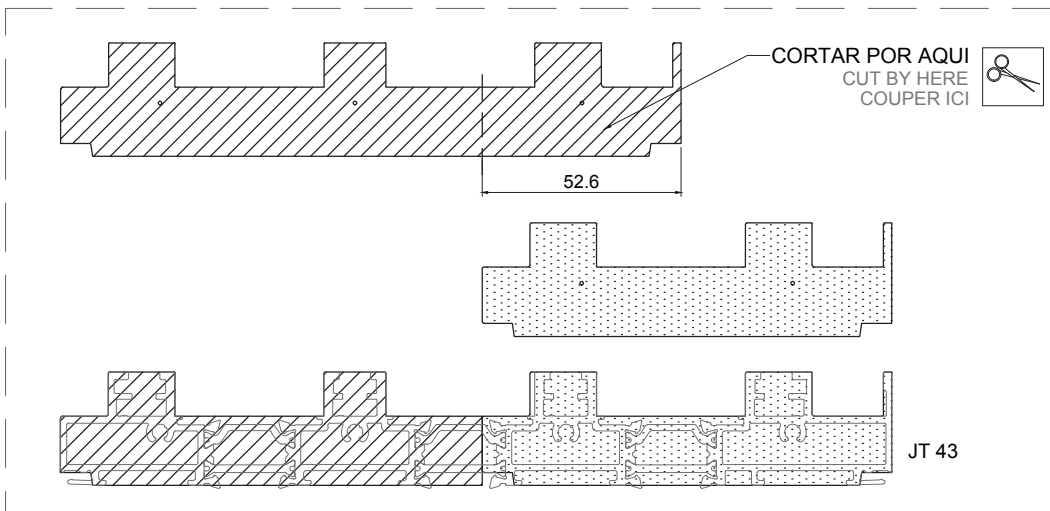
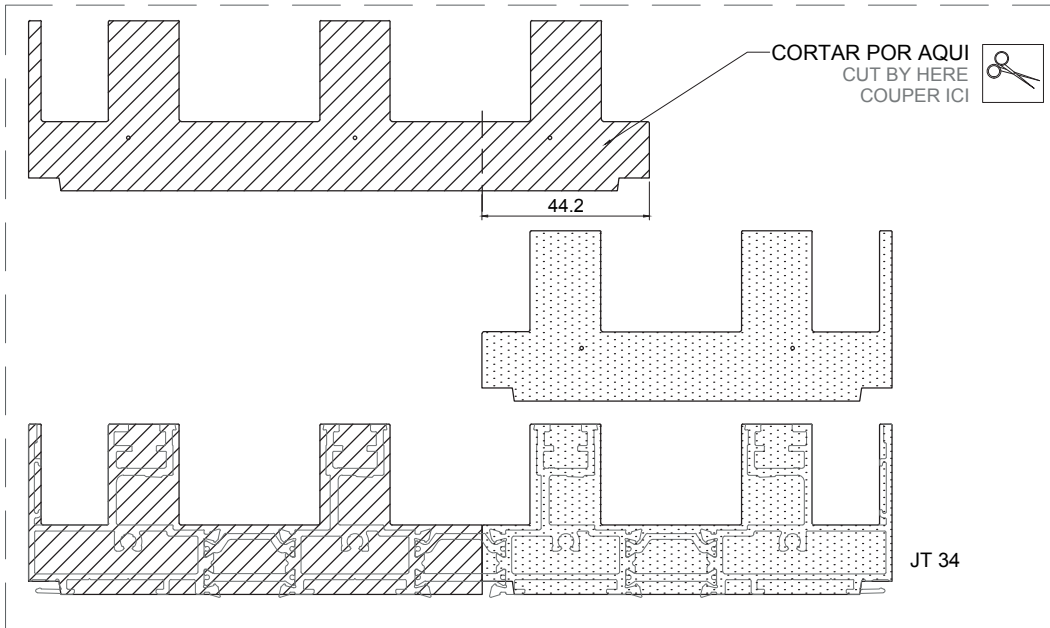
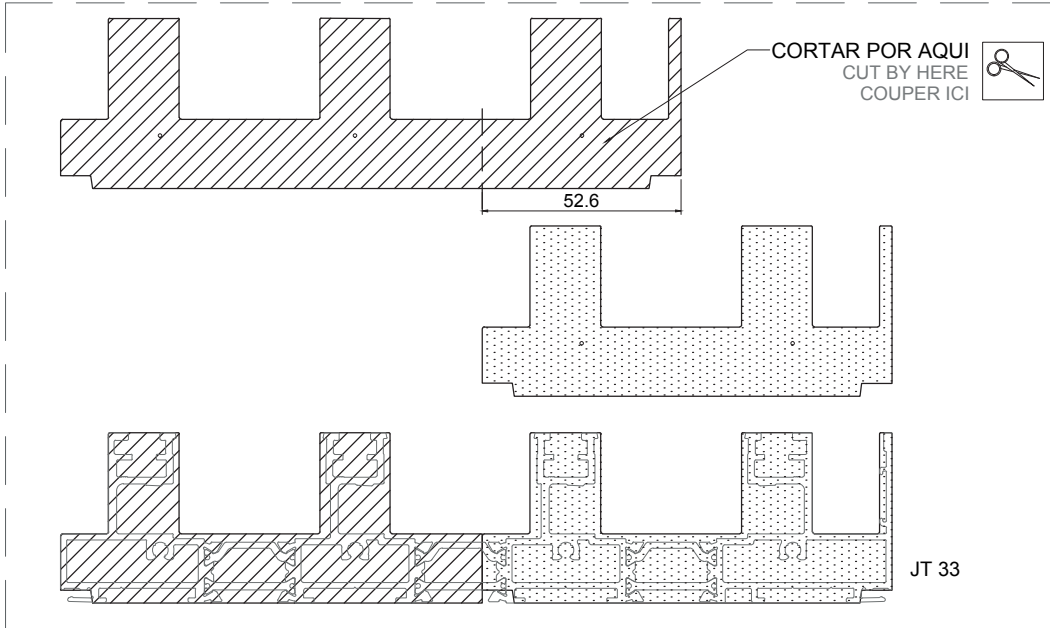

223105 KIT JUNTAS ADESIVAS Nº1 JT

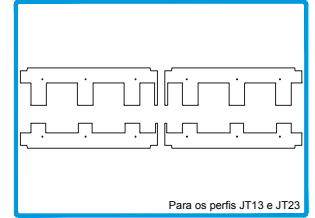

223106 KIT JUNTAS ADESIVAS Nº2 JT

**MONTAGEM DOS PERFIS ARO FIXO COM SOLEIRA 30MM (CORTE 90°)**

FIXED FRAME PROFILES ASSEMBLY WITH 30MM SILL PROFILE (90° CUT)

ASSEMBLAGE DES PROFILÉS DORMANT AVEC SEUIL 30MM (COUPE 90°)

**4 - Aplicação do perfil pingadeira JT82.**

JT82 drip profile application.  
Application du profilé larmier JT82.

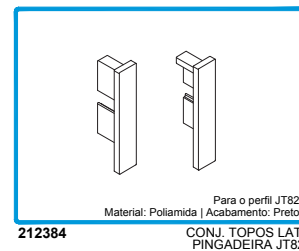
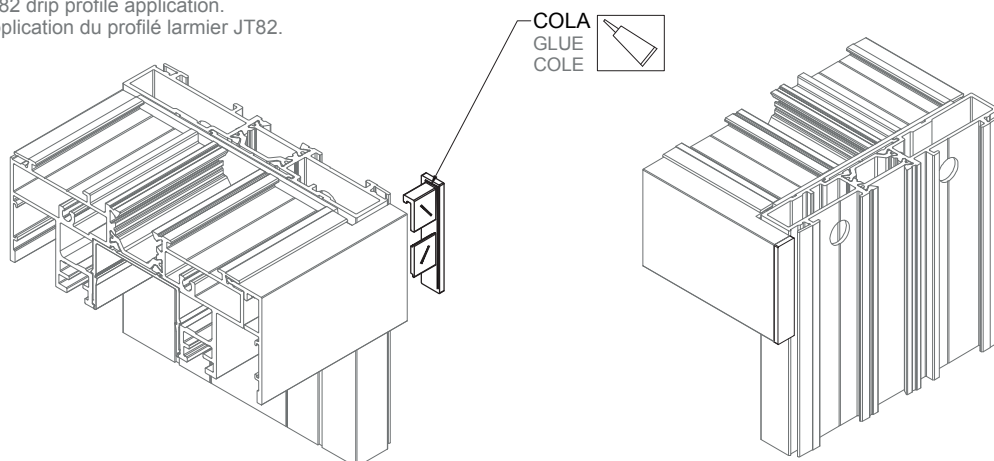

**5 - Enchimento das câmaras nos 4 lados do aro fixo e colocação do aro ao sítio.**

Filling the chambers on the 4 sides of the fixed frame and placing the frame in place.  
Remplissage des chambres sur les 4 côtés du cadre dormant et mise en place du cadre.

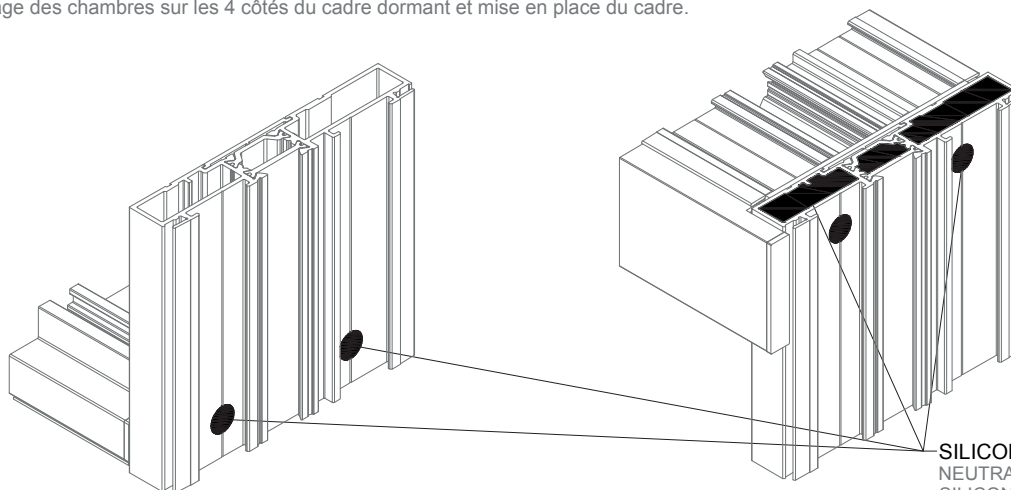

**6 - Aplicação dos perfis JT78 e JT79 nas ombreiras.**

JT78 and JT79 application in jamb profiles.  
Application des profilés JT78 et JT79 sur les jambages.

**Passo | Step | Étape 1:**

**Colocar o perfil guia lateral na ombreira.**  
Place the lateral guide profile in the jamb.  
Placer le de guidage latéral sur le jambage.

**Passo | Step | Étape 2:**

**Furar os perfis guia lateral e ombreira.**  
Drill the lateral guide and jamb profiles.  
Perçer le guide latéral et les profilés de jambage.

**Passo | Step | Étape 3:**

**Fixar a guia lateral à ombreira usando parafusos.**  
Fix the lateral guide into the jamb using screws.  
Fixer le guidage latéral au jambage à l'aide de vis.

**Passo | Step | Étape 4:**

**Aplicar o vedante tapa canal 2116.**  
Apply the 2116 channel cover joint.  
Appliquer le joint de couverture 2116.

**Passo | Step | Étape 5:**

**Aplicar os perfis guia inferiores JT87.**  
Apply the JT87 bottom guide profile.  
Appliquer les profilés de guide inférieures JT87.

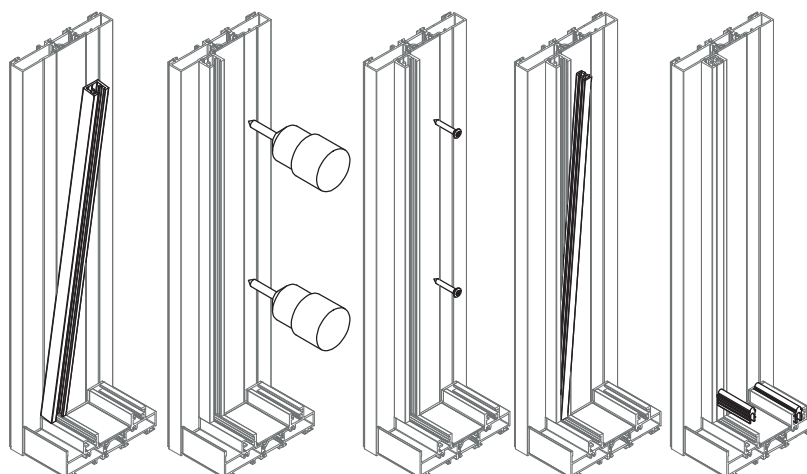
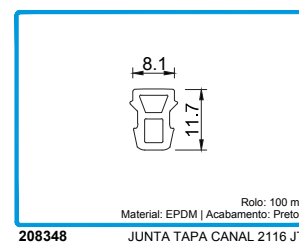
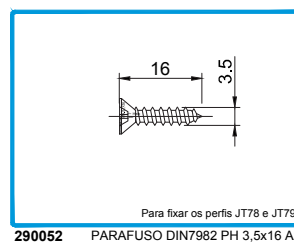

O vedante tem de ser interrompido onde se localizarão os contra-fechos (a zona de interrupção deverá ser suficiente para permitir os movimentos do fecho multiponto SOT).  
The joint must be interrupted where the counter-locks will be located (the interrupted zone must be sufficient to allow the movements of the SOT multipoint lock).  
Le joint doit être interrompu à l'endroit où seront situées les contre-serrures (la zone d'interruption doit être suffisante pour permettre les mouvements de la serrure multipoint SOT)

**MONTAGEM DOS PERFIS ARO FIXO COM SOLEIRA 30MM (CORTE 90°)**

FIXED FRAME PROFILES ASSEMBLY WITH 30MM SILL PROFILE (90° CUT)

ASSEMBLAGE DES PROFILÉS DORMANT AVEC SEUIL 30MM (COUPE 90°)

**7 - Aplicação dos conjunto união reta e canto 90° JT.**

Straight union kit and angles applying in fixed frames.

Application du kit d'union droit et angle 90° JT.

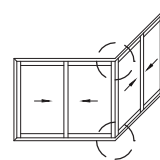

**IMPORTANT | IMPORTANT | IMPORTANT:**

Encher as câmaras com silicone antes de colocar as peças que constituem os conjuntos, fixá-las conforme esquemas abaixo e aplicar silicone à cor do perfil ou silicone neutro na zona das esquadrias.

Fill the chambers with silicone before placing the pieces that constitute the kits, fix them according to the following schemes and apply silicone in the same color as the profiles or neutral silicone in the frame's areas.

Remplir les chambres de silicone avant de placer les pièces qui composent les ensembles, fixer-les selon les schémas ci-dessous et appliquer du silicone sur la couleur du profilé ou du silicone neutre dans la zone des cadres.

**APLICAÇÃO NA PADIEIRA | LINTEL APPLICATION | APPLICATION DANS LE LINTEAU**

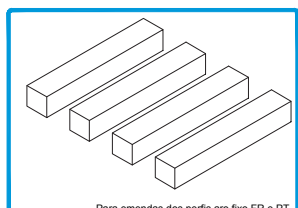

212242 CONJ. UNIÃO RETA JT

OU | OR | OU

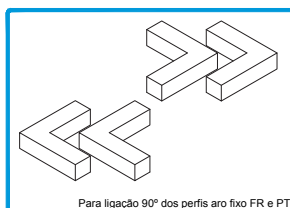

212243 CONJ. UNIÃO CANTO 90° JT

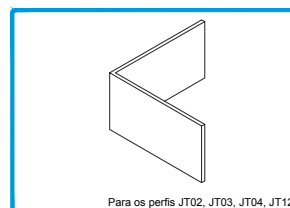

204389 ESQUADRO INOX CANTO 90°

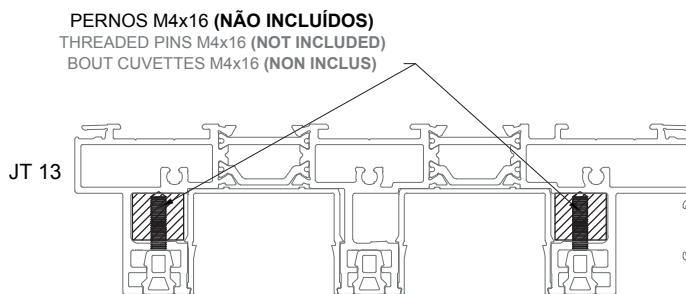
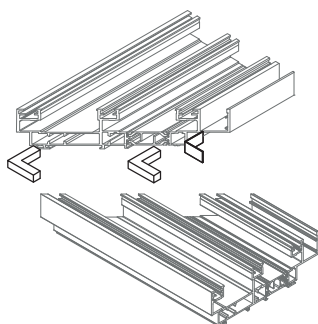

**PERNOS M4x16 (NÃO INCLUIDOS)**  
THREADED PINS M4x16 (NOT INCLUDED)  
BOUT CUVETTES M4x16 (NON INCLUS)

**APLICAÇÃO NA SOLEIRA | SILL APPLICATION | APPLICATION DANS LE SEUIL**

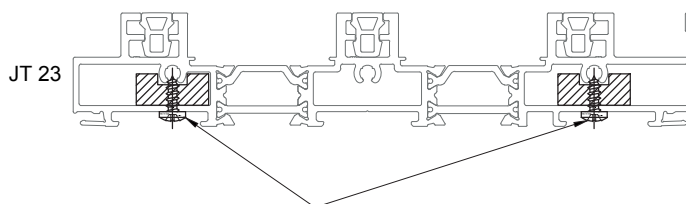
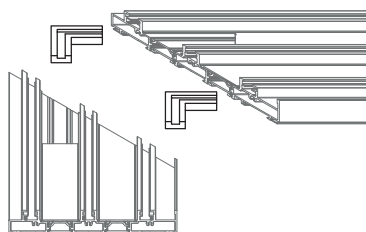

**PARAF. DIN7981 3,5x10 (NÃO INCLUIDOS)**  
SCREWS DIN7981 3,5x10 (NOT INCLUDED)  
VIS DIN7981 3,5x10 (NON INCLUS)

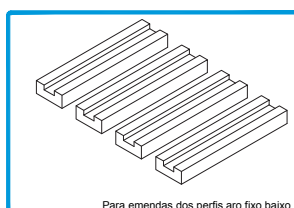

212083 CONJ. UNIÃO RETA ARO BAIXO JT

OU | OR | OU

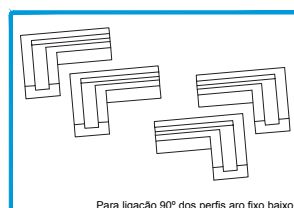

212084 CONJ. UNIÃO CANTO 90° ARO BAIXO JT

**MONTAGEM DOS PERFIS ARO FIXO COM SOLEIRA 30MM (CORTE 90°)**

FIXED FRAME PROFILES ASSEMBLY WITH 30MM SILL PROFILE (90° CUT)

ASSEMBLAGE DES PROFILÉS DORMANT AVEC SEUIL 30MM (COUPE 90°)

**8 - Montagem de aros fixos, em tipologias de canto 90°.**

Fixed frames assembly, in 90° corner typologies.

Montage de cadres dormant, en types d'angle à 90°.

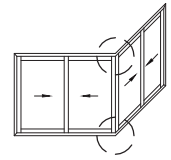

**8.1 - Colocar as peças que constituem o conj. união e os esquadros inox canto 90° nos perfis e fixá-los com pernos e parafusos (ver página anterior).**

Place the 90° corner union kit pieces and inox corners in to the profiles and fix them with threaded pins and screws (see previous page).

Placer les pièces qui composent le jeu d'union et les supports en acier inoxydable d'angle à 90° sur les profilés et les fixer avec des bout cuvettes and vis (voir page précédente).

**8.2 - Cortar os perfis JE96 antes de aplicar o corta-vento baixo.**

Cut the JE 96 profiles before applying the low central waterproofing pile seal.

Couper les profilés JE96 avant d'appliquer le brosse centrale d'étanchéité bas.

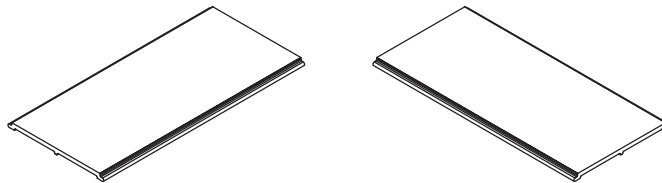

**8.3 - Aplicar o corta-vento canto 90° JT no aro fixo.**

Apply the 90° corner insulation gasket in the fixed frame.

Appliquer le brosse d'étanchéité angle 90°.

As medidas de corte dos perfis PVC T encontram-se no mapa de quantidades das tipologias de canto.

The cutting measures of the T PVC profiles can be found in the corners typologies quantity map.

Les mesures de coupe des profilés PVC T se trouvent dans la carte de quantité des typologies d'angle.

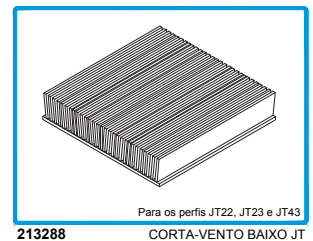

213288

Para os perfis JT22, JT23 e JT43  
CORTA-VENTO BAIXO JT

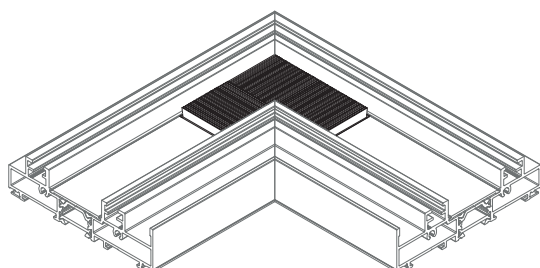
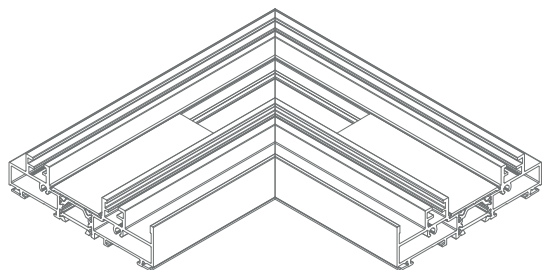
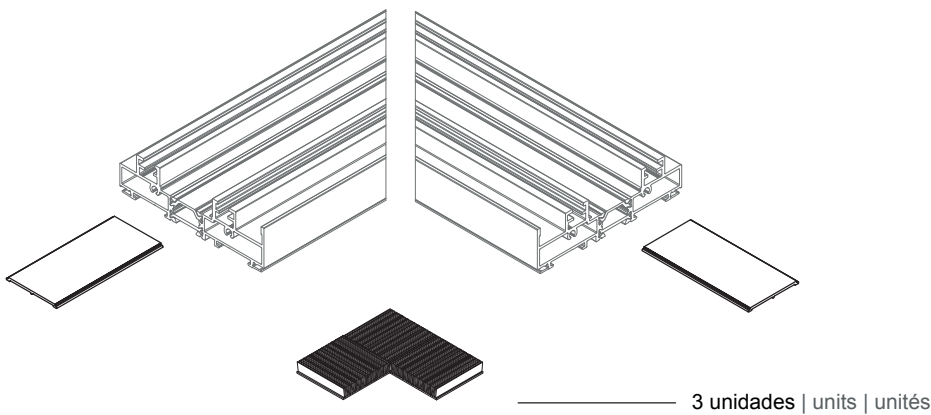

**IMPORTANTE | IMPORTANT | IMPORTANT:**  
Os perfis PVC T superiores só deverão ser colocadas depois de os aros móveis estarem aplicados.  
The upper T PVC profiles must only be installed after the mobile frames are applied.  
Les profilés PVC T supérieures ne doivent être installés qu'après la pose des cadres ouvrants.

**MONTAGEM DOS PERFIS ARO FIXO PT (CORTE 45°) COM SOLEIRA 30MM (CORTE 90°)**

PT FIXED FRAME PROFILES ASSEMBLY (45° CUT) WITH 30MM SILL PROFILE (90° CUT)

ASSEMBLAGE DES PROFILÉS DORMANT PT (COUPE 45°) AVEC SEUIL 30MM (COUPE 90°)

**1 - Ligação entre aros fixos.**

Fixed frames connection.  
Connexions sur les cadres dormants.

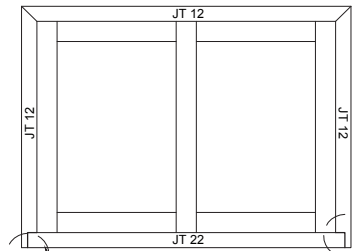
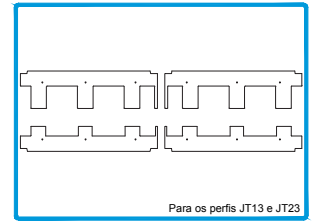
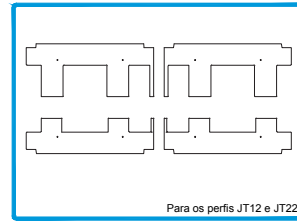

KIT JUNTAS ADESIVAS Nº1 JT  
Nº1 JT ADHESIVE JOINTS KIT  
JOINTS ADHÉSIFS KIT Nº1 JT

KIT JUNTAS ADESIVAS Nº1 JT  
Nº1 JT ADHESIVE JOINTS KIT  
JOINTS ADHÉSIFS KIT Nº1 JT

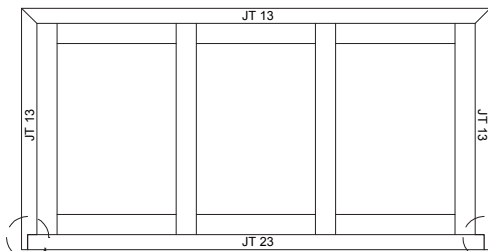

KIT JUNTAS ADESIVAS Nº2 JT  
Nº2 JT ADHESIVE JOINTS KIT  
JOINTS ADHÉSIFS KIT Nº2 JT

KIT JUNTAS ADESIVAS Nº2 JT  
Nº2 JT ADHESIVE JOINTS KIT  
JOINTS ADHÉSIFS KIT Nº2 JT

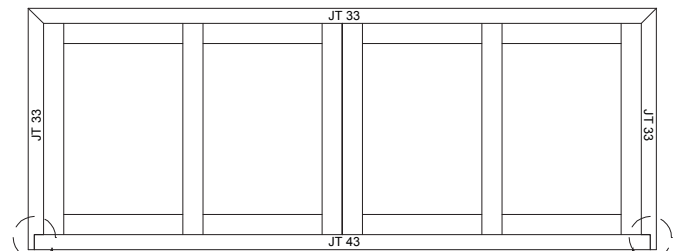

KIT JUNTAS ADESIVAS Nº1 + Nº2 JT  
Nº1 + Nº2 JT ADHESIVE JOINTS KIT  
JOINTS ADHÉSIFS KIT Nº1 + Nº2 JT

KIT JUNTAS ADESIVAS Nº1 + Nº2 JT  
Nº1 + Nº2 JT ADHESIVE JOINTS KIT  
JOINTS ADHÉSIFS KIT Nº1 + Nº2 JT

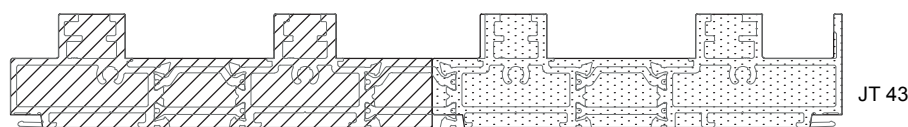
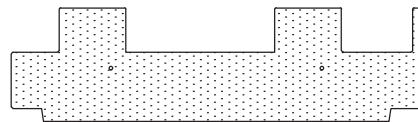
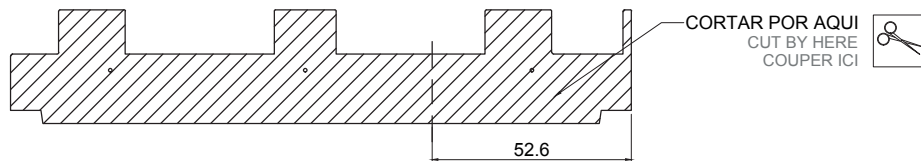

**2 - Fixação dos perfis Ombreira/Soleira**

Fixing the profiles Jamb/Sill  
Fixation des profilés Jambage/Seuil

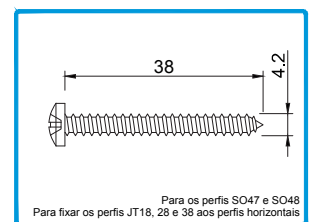
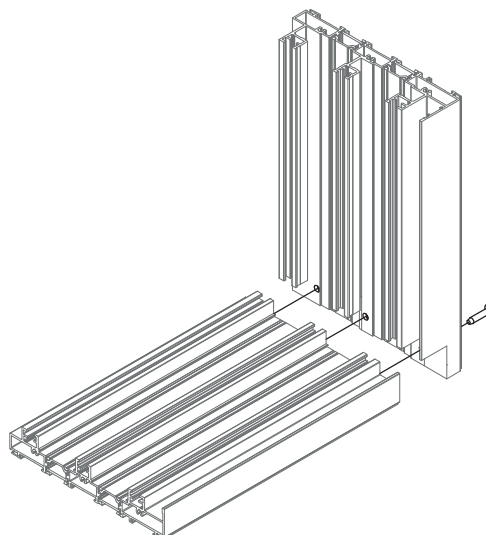
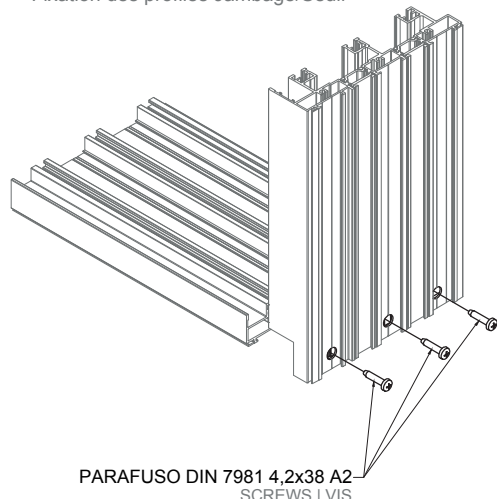

290030 PARAFUSO DIN7981 4,2x38 INOX A2

**MONTAGEM DE TIPOLOGIAS DE EMBUTIR**  
HIDDEN SLIDING TYPOLOGIES ASSEMBLY  
ASSEMBLAGE DE TYPOLOGIES À GALANDAGE

**1 - Pormenores de aplicação.**  
Application details.  
Détails de l'application.

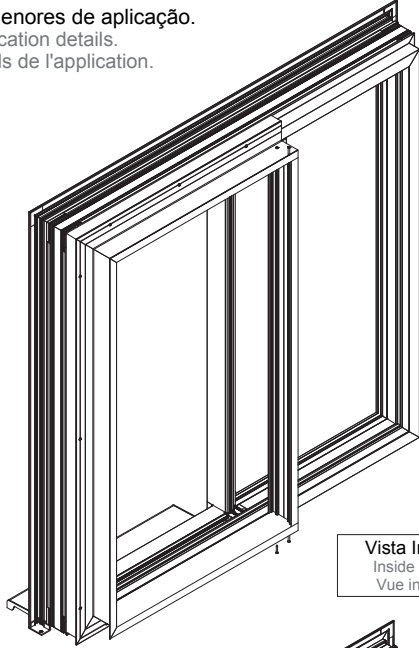

**Vista Interior - Aro Fixo FR**  
Inside View - FR Fixed frame  
Vue intérieure - Dormant FR

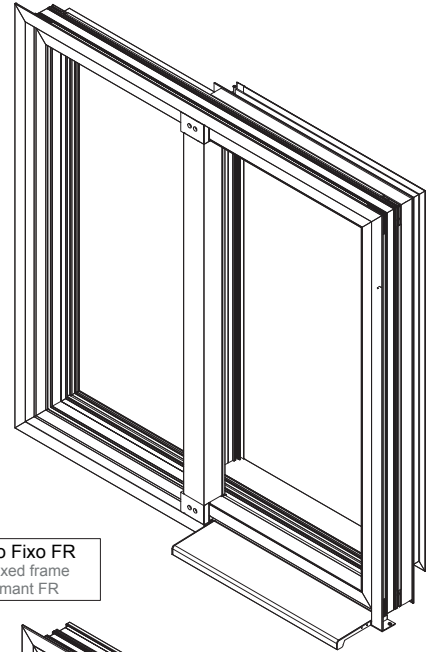

**Vista Exterior - Aro Fixo FR**  
Outside View - FR Fixed frame  
Vue extérieure - Dormant FR

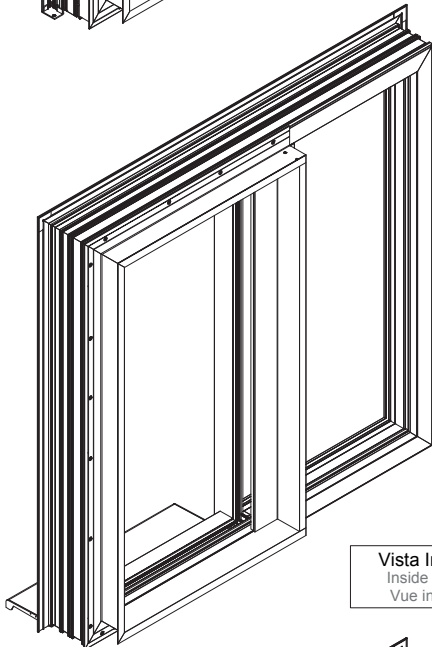

**Vista Interior - Aro Fixo PT**  
Inside View - PT Fixed frame  
Vue intérieure - Dormant PT

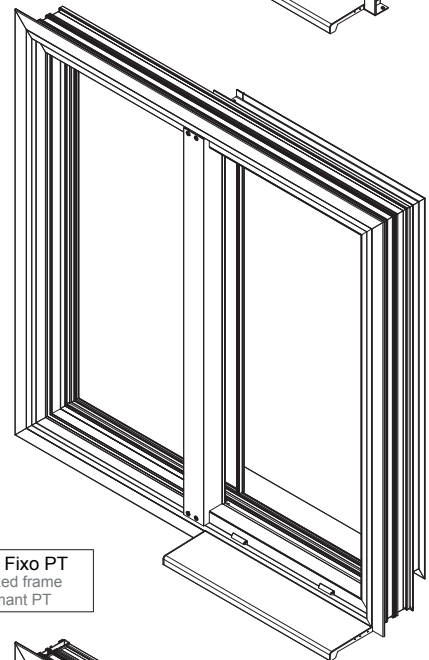

**Vista Exterior - Aro Fixo PT**  
Outside View - PT Fixed frame  
Vue extérieure - Dormant PT

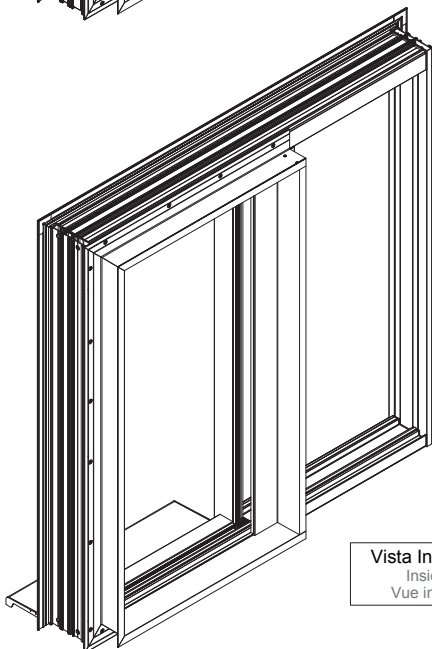

**Vista Interior - Soleira 30mm**  
Inside View - 30mm Sill  
Vue intérieure - Seuil 30mm

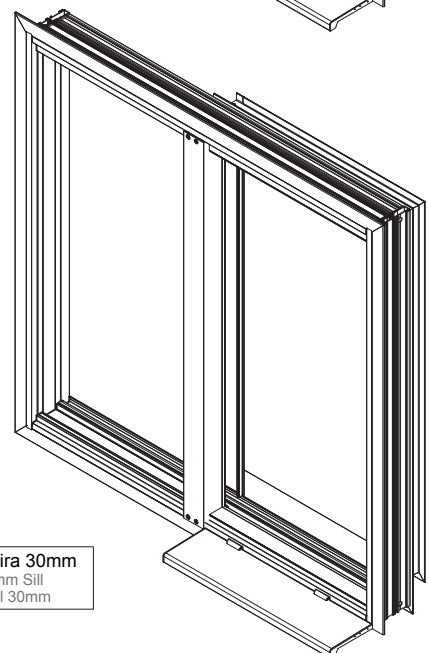

**Vista Exterior - Soleira 30mm**  
Outside View - 30mm Sill  
Vue extérieure - Seuil 30mm



**MONTAGEM DE TIPOLOGIAS DE EMBUTIR**  
HIDDEN SLIDING TYPOLOGIES ASSEMBLY  
ASSEMBLAGE DE TYPOLOGIES À GALANDAGE

**2 - Aplicação de acessórios para perfis KE 71 e KE 90 / KE 60.**

Accessories application for KE 71 and KE 90 / KE 60 profiles.  
Application des accessoires pour les profilés KE 71 et KE 90 / KE 60.

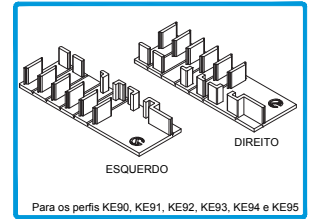
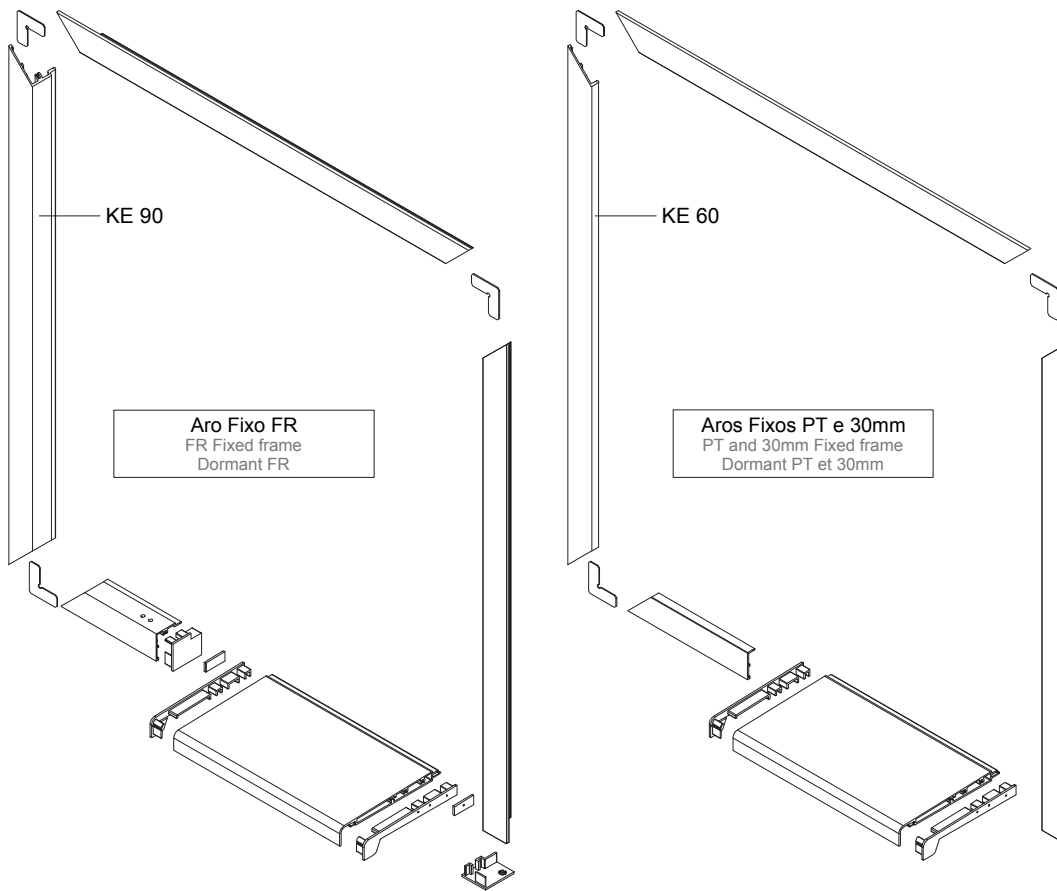

212223 CONJ. TOPOS INFERIORES RENOVATIO

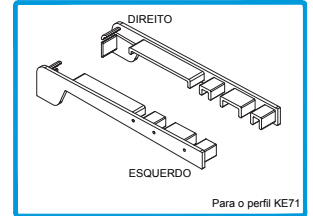

212221 CONJUNTO TAPA TOPOS KE 71

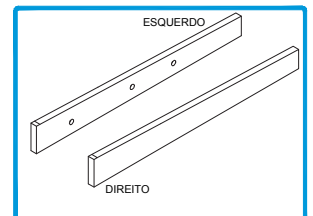

212227 CONJ. JUNTAS ADESIVAS P/ TOPOS PERFIL SOLEIRA KE 71

**3 - Medidas de corte e maquinações dos perfis KE 90 / KE 60 horizontais.**

Cutting measures and machining for KE 90 / KE 60 horizontal profiles.  
Mesures de coupe et usinage des profilés horizontaux KE 90 / KE 60.

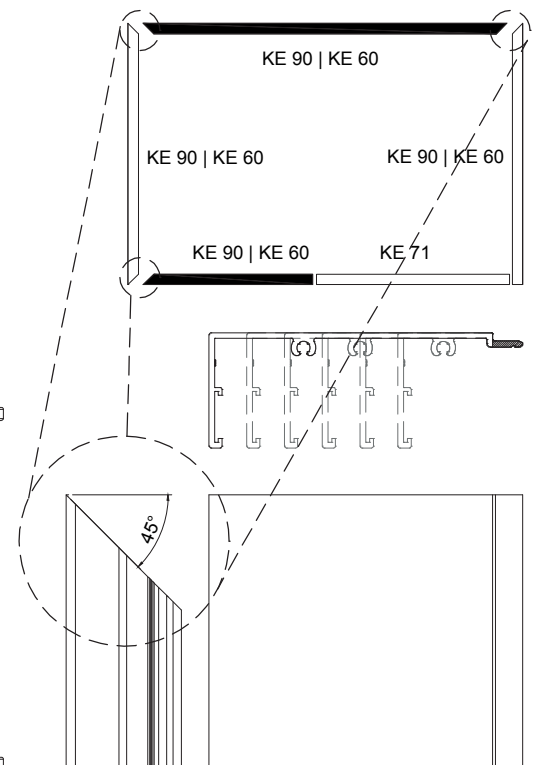
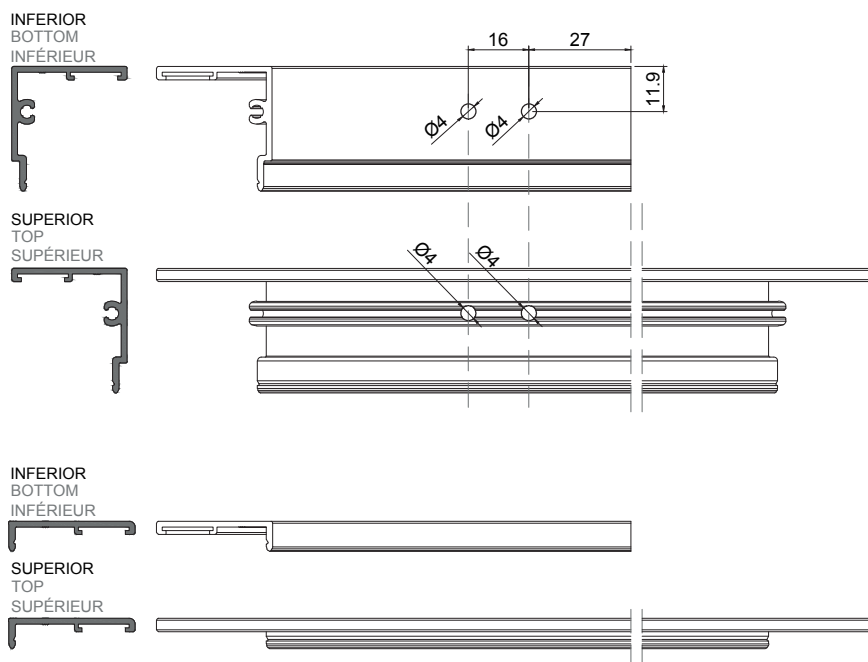



**MONTAGEM DE TIPOLOGIAS DE EMBUTIR**  
HIDDEN SLIDING TYPOLOGIES ASSEMBLY  
ASSEMBLAGE DE TYPOLOGIES À GALANDAGE

- 4 - Colocar o perfil KE 71 no aro fixo e colocar os seus topos nas extremidades, utilizando cola.  
Place the KE 71 profile in the fixed frame and place their tops at the ends, using glue.  
Placer le profilé KE 71 dans le cadre fixe et placer leurs sommets aux extrémités, à l'aide de colle.

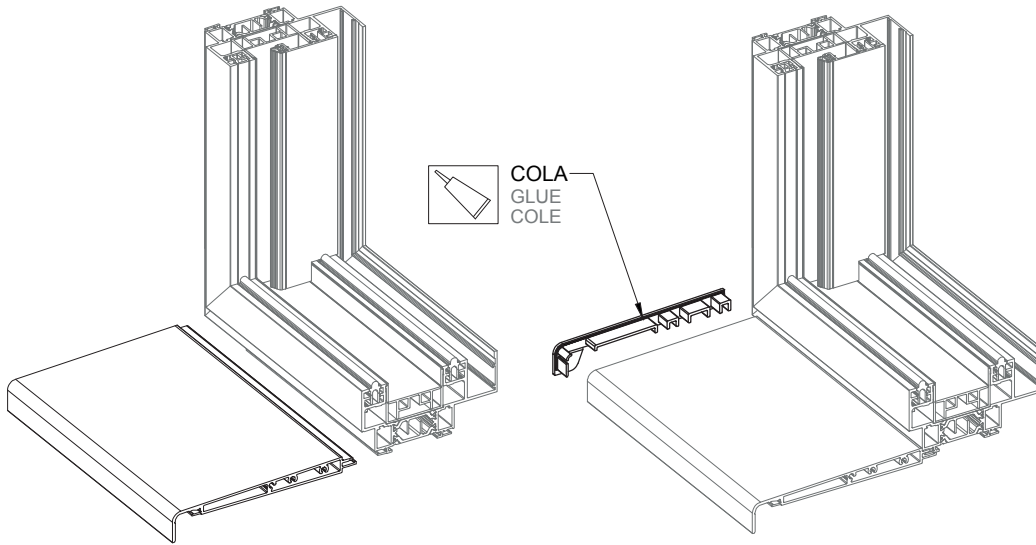
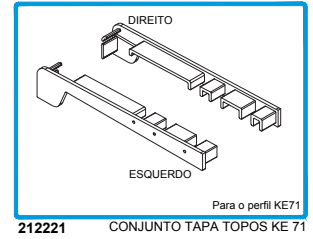

- 5 - **Em vãos FR**, aplicar a junta adesiva no topo KE 71 e colocar posteriormente os perfis de remate.  
**In FR fixed frames**, apply the adhesive joint at the KE 71 end-cap and then place the finishing profiles.  
**Dans les dormants FR**, appliquer le joint adhésif sur le embout KE 71 et puis placer les profilés de finition.

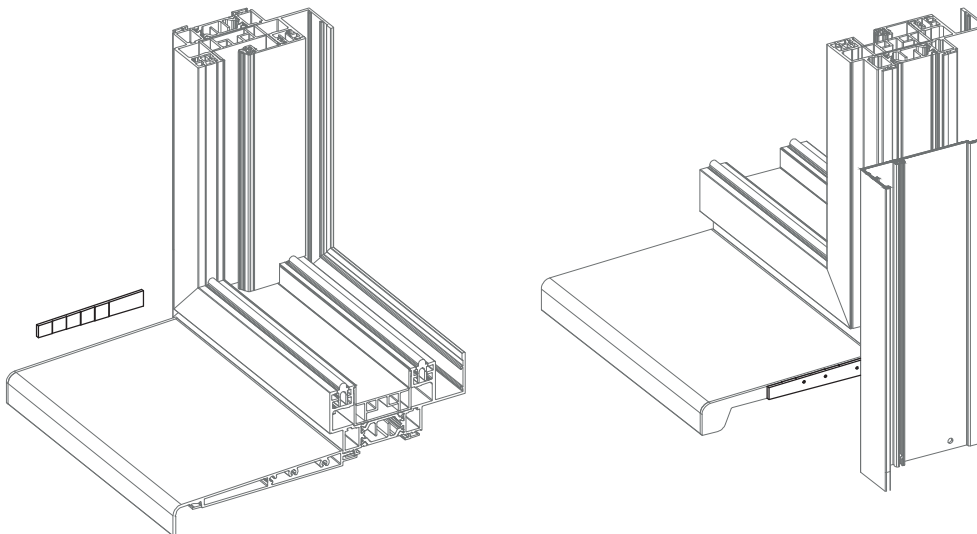
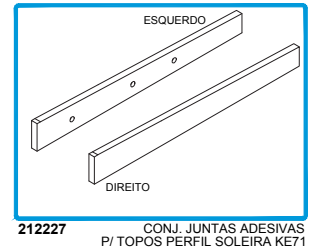

- 6 - **Em vãos FR**, cortar o Conj. de topos inferiores renovatio na utilização dos perfis KE90, KE91, KE92, KE93, KE94 e KE95 e aplicar cola no topo antes de o aplicar.  
**In FR fixed frames**, cut the renovatio lower end-caps kit when using KE90, KE91, KE92, KE93, KE94 and KE95 profiles and apply glue in the end-cap before applying it.  
**Dans les dormants FR**, couper le jeu de dessus inférieurs renovatio lors de l'utilisation des profilés KE90, KE91, KE92, KE93, KE94 et KE95 et appliquer de la colle sur le dessus avant de l'appliquer.

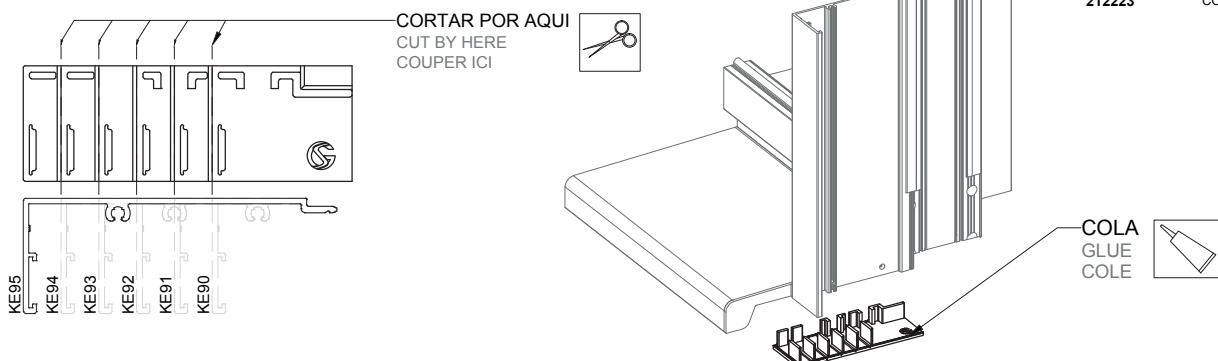
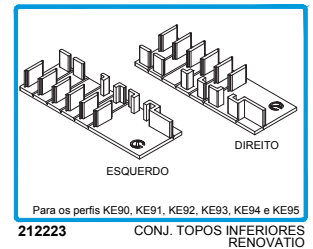

**MONTAGEM DE TIPOLOGIAS DE EMBUTIR**  
HIDDEN SLIDING TYPOLOGIES ASSEMBLY  
ASSEMBLAGE DE TYPOLOGIES À GALANDAGE

**7 - Em vãos FR,** fixar o topo e o perfil lateral de remate à soleira KE 71e preencher com silicone.  
**In FR fixed frames,** fix the end-cap and the lateral finishing profile to the KE 71 sill and fill with silicone.  
**Dans les dormants FR,** fixer les profilés supérieur et latéral au seuil KE 71 et remplir de silicone.

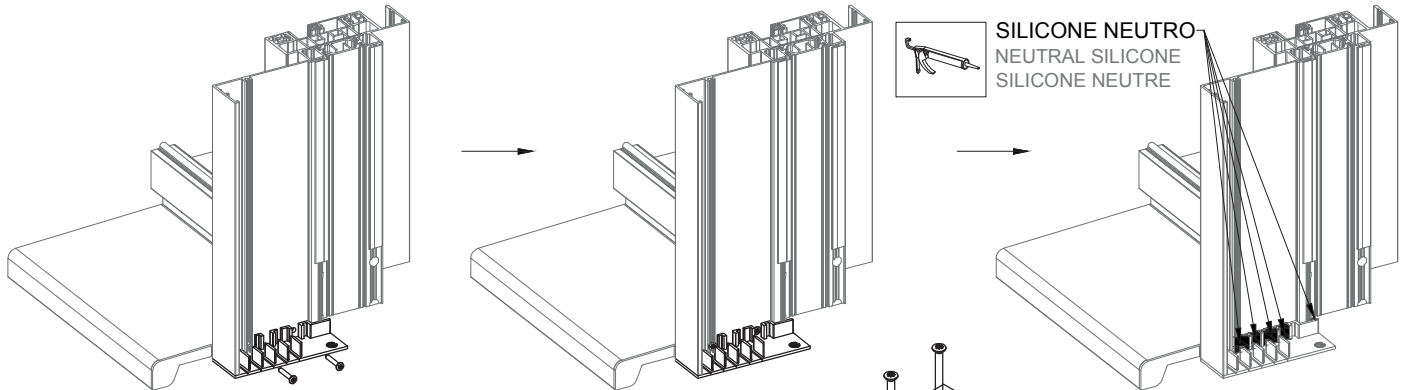

**8 - Aplicação do perfil montante para solução de embutir JT 93 e acessórios.**  
JT 93 mullion profile for pocket solution and accessories application.  
Application du profilé de meneau pour galandage JT 93 et accessoires.

**8.1 - Aro fixo FR.**  
FR fixed frame.  
Dormant FR.

**Passo | Step | Étape 1:**  
**Aplicar cola nas extremidades do perfil JT93.**  
Apply glue to the ends of the profile.  
Perçer le guide latéral et les profilés de jambage.

**Passo | Step | Étape 2:**  
**Aparafusar os topos ao perfil.**  
Screw the end-caps to the profile.  
Fixer le guidage latéral au jambage à l'aide de vis.

**Passo | Step | Étape 3:**  
**Fixar o perfil JT93 ao aro fixo.**  
Fix the JT93 profile to the fixed frame.  
Fixer le profilé JT93 au le cadre dormant.

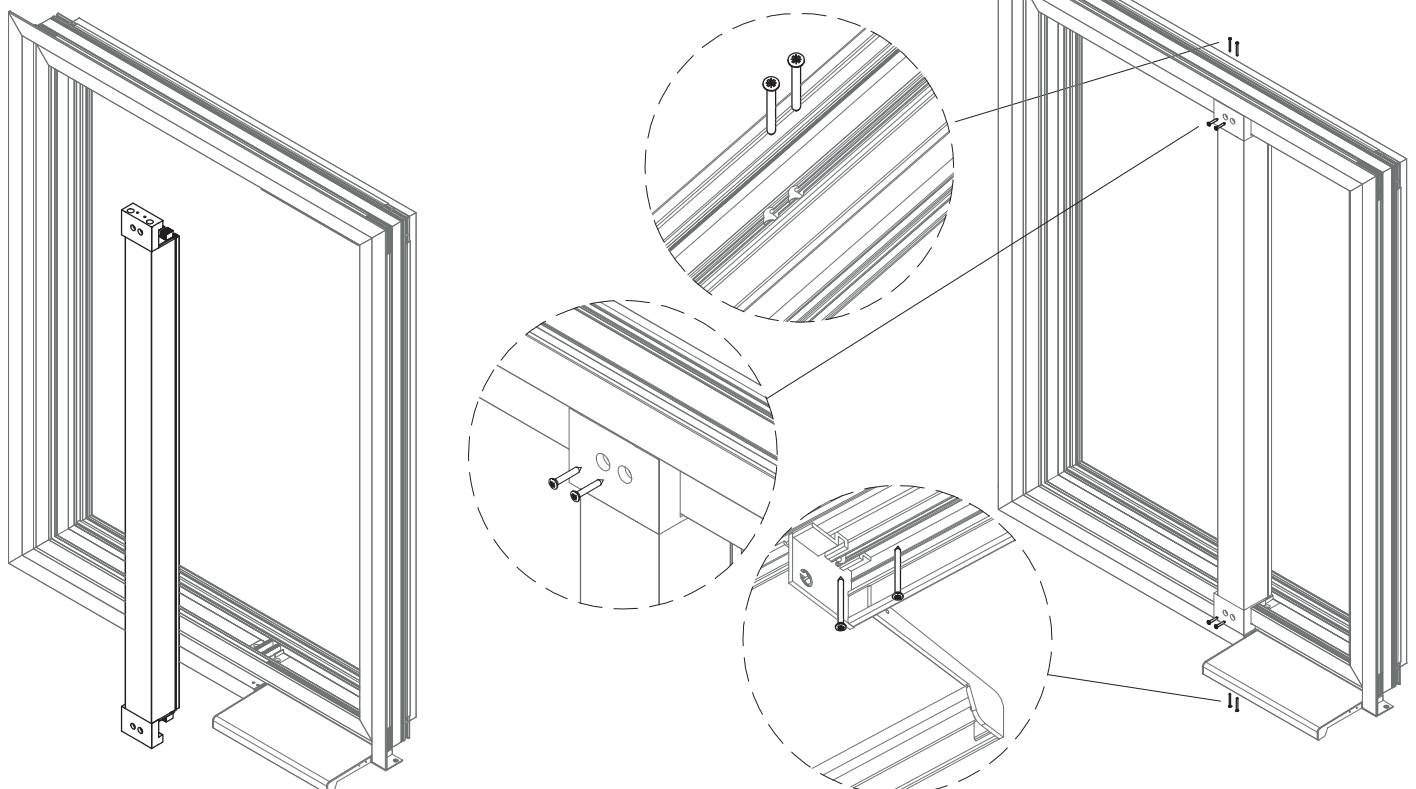
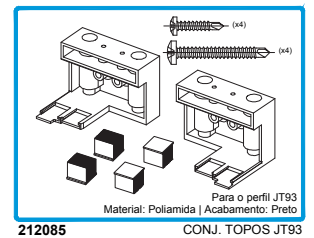
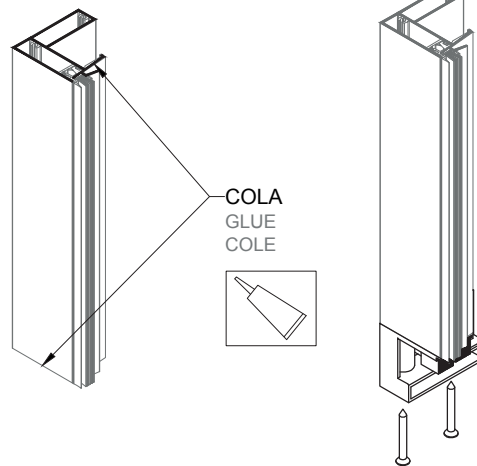

**MONTAGEM DE TIPOLOGIAS DE EMBUTIR**  
HIDDEN SLIDING TYPOLOGIES ASSEMBLY  
ASSEMBLAGE DE TYPOLOGIES À GALANDAGE

**8 - Aplicação do perfil montante para solução de embutir JT 93 e acessórios.**  
JT 93 mullion profile for pocket solution and accessories application.  
Application du profilé de meneau pour galandage JT 93 et accessoires.

**8.2 - Aros fixo PT e 30mm.**  
PT and 30mm fixed frame.  
Dormants PT et 30mm.

**Passo | Step | Étape 1:**  
Posicionar o perfil JT 93 no aro fixo.  
Position the JT 93 profile on the fixed frame.  
Positionner le profilé JT 93 sur le dormant.

**Passo | Step | Étape 2:**  
Fixar o perfil JT93 ao aro fixo.  
Fix the JT93 profile to the fixed frame.  
Fixer le profilé JT93 au le cadre dormant.

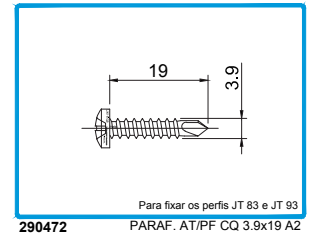
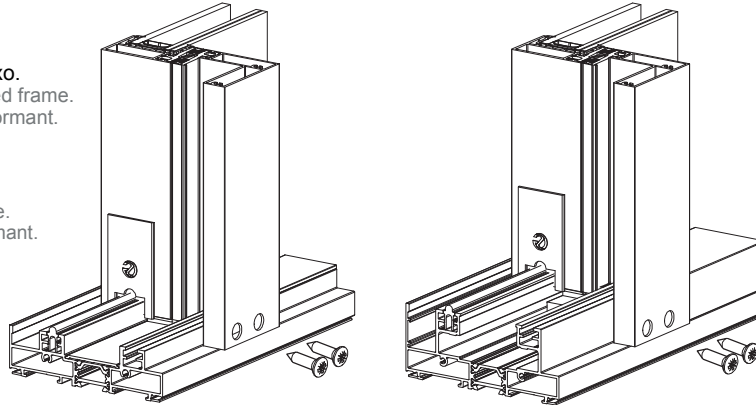

**9 - Aplicação da Junta tapa canal 2116 JT e dos perfis guia JT87.**  
2116 channel cover joint and JT87 guide profiles application.  
Application du joint de recouvrement de canal 2116 JT et des profilés de guide JT87.

**Aplicação superior e inferior da Junta tapa canal no rail vazio e no rail superior da folha móvel**  
Upper and lower application of the channel cover joint on the empty rail and upper application on the mobile frame upper rail  
Application supérieure et inférieure du joint de couvercle de canal sur le rail vide et le rail supérieur de la feuille mobile

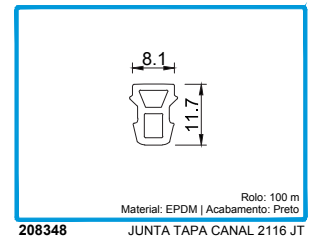
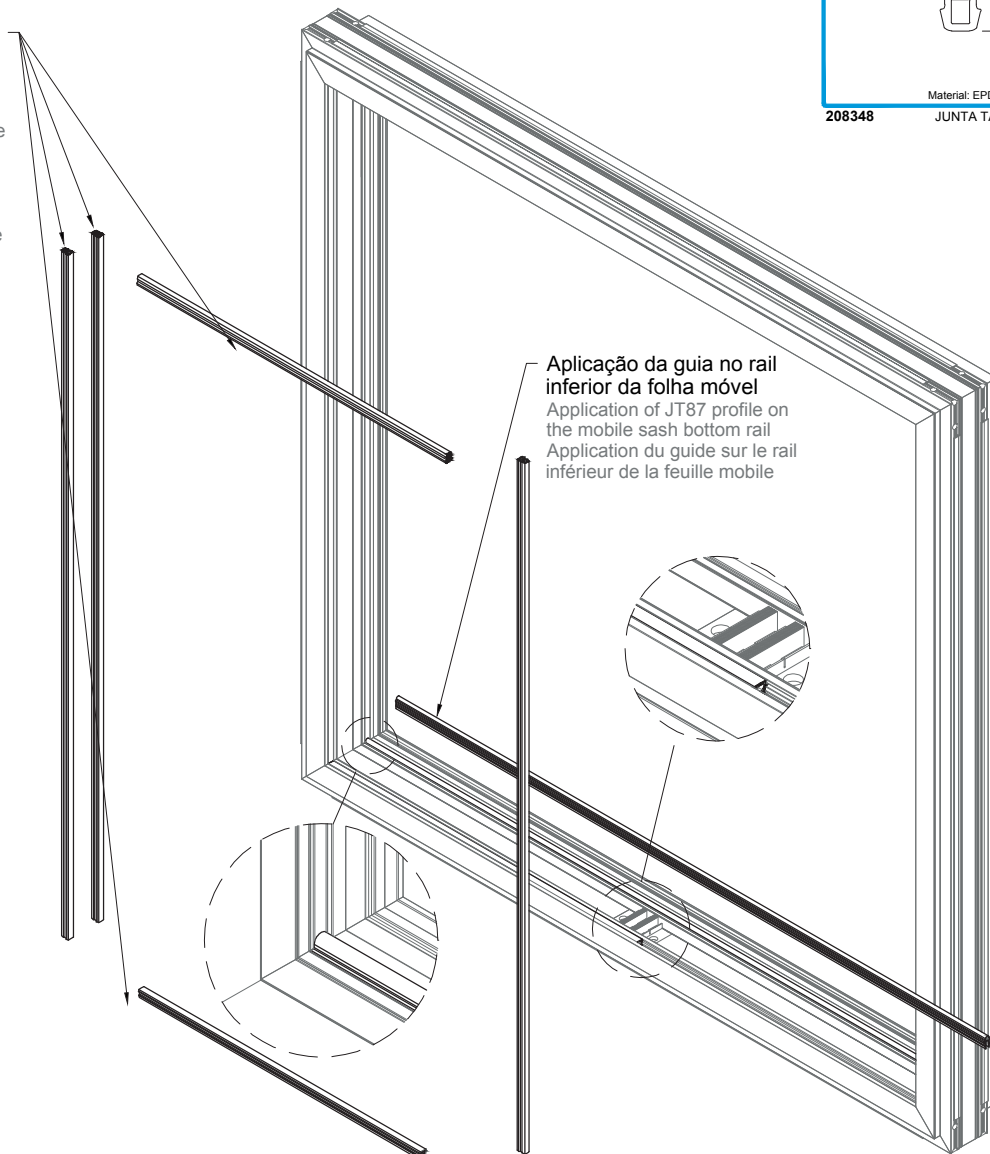

**MONTAGEM DE TIPOLOGIAS DE EMBUTIR**  
HIDDEN SLIDING TYPOLOGIES ASSEMBLY  
ASSEMBLAGE DE TYPOLOGIES À GALANDAGE

10 - Aplicação dos perfis capa JT85 e JT88.  
JT85 and JT88 cover profiles application.  
Application des profilés de capot JT85 et JT88.

**IMPORTANTE | IMPORTANT | IMPORTANT:**

As pelúcias já deverão estar colocadas nos perfis de capa antes da sua aplicação e deverão ser aplicadas primeiro as alturas e só depois as larguras.

The pile seals must already be placed on the cover profiles before application and the heights must be applied first and only then the widths.

Les joint brosses doivent déjà être placées sur les profilés de capot avant d'être appliquées et doivent être appliquées d'abord en hauteurs puis en largeurs.

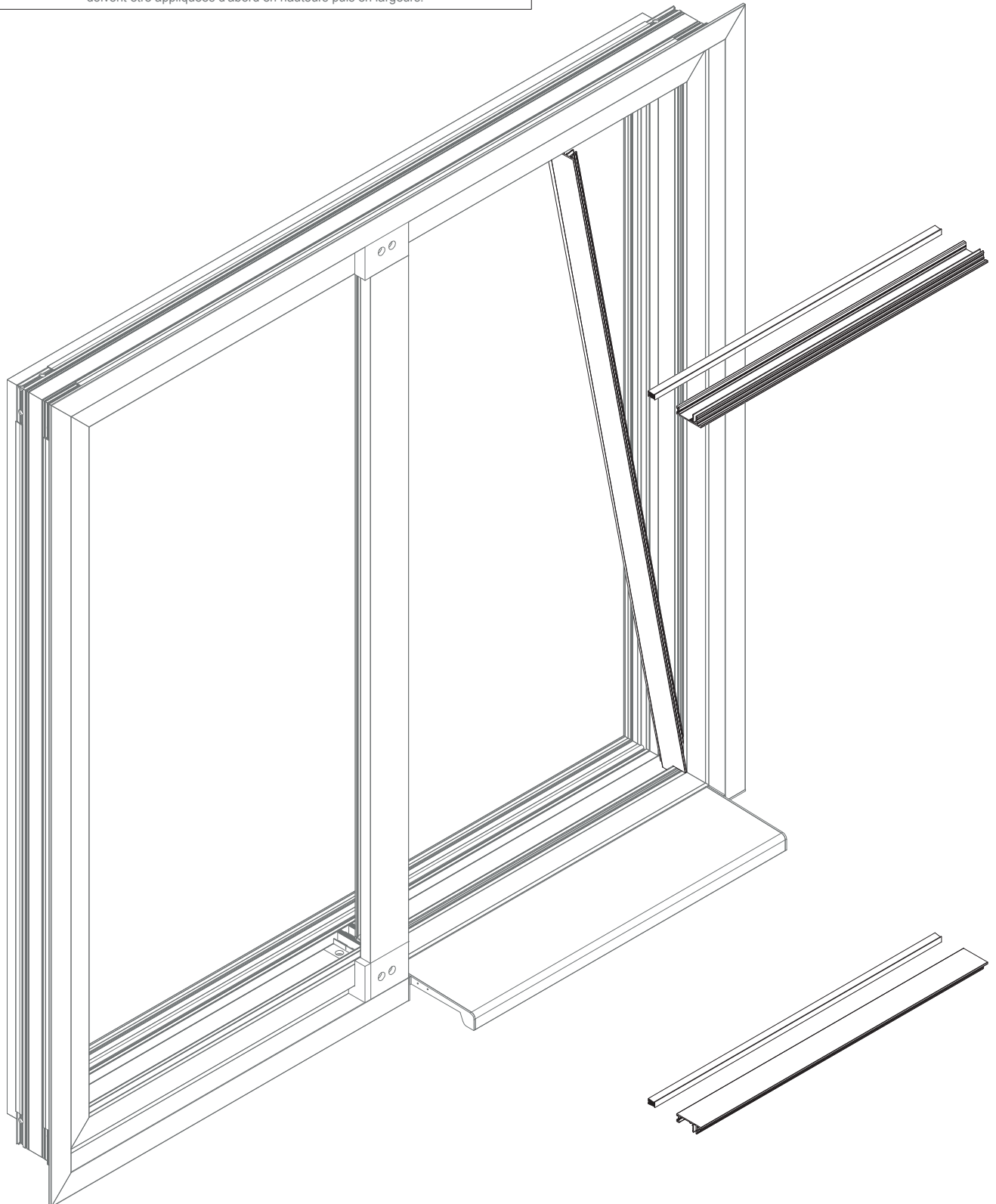

**MONTAGEM DE TIPOLOGIAS DE EMBUTIR**  
HIDDEN SLIDING TYPOLOGIES ASSEMBLY  
ASSEMBLAGE DE TYPOLOGIES À GALANDAGE

**11 - Corte e maquinações dos perfis de remate.**  
Finishing profiles cutting and milling.  
Découpe et usinage des profilés de finition.

**IMPORTANT | IMPORTANT | IMPORTANT:**  
As medidas de corte podem variar consoante a tipologia do vão.  
The cutting measures may vary according to the typology of the frame.  
Les mesures de coupe peuvent varier en fonction du type de travée.

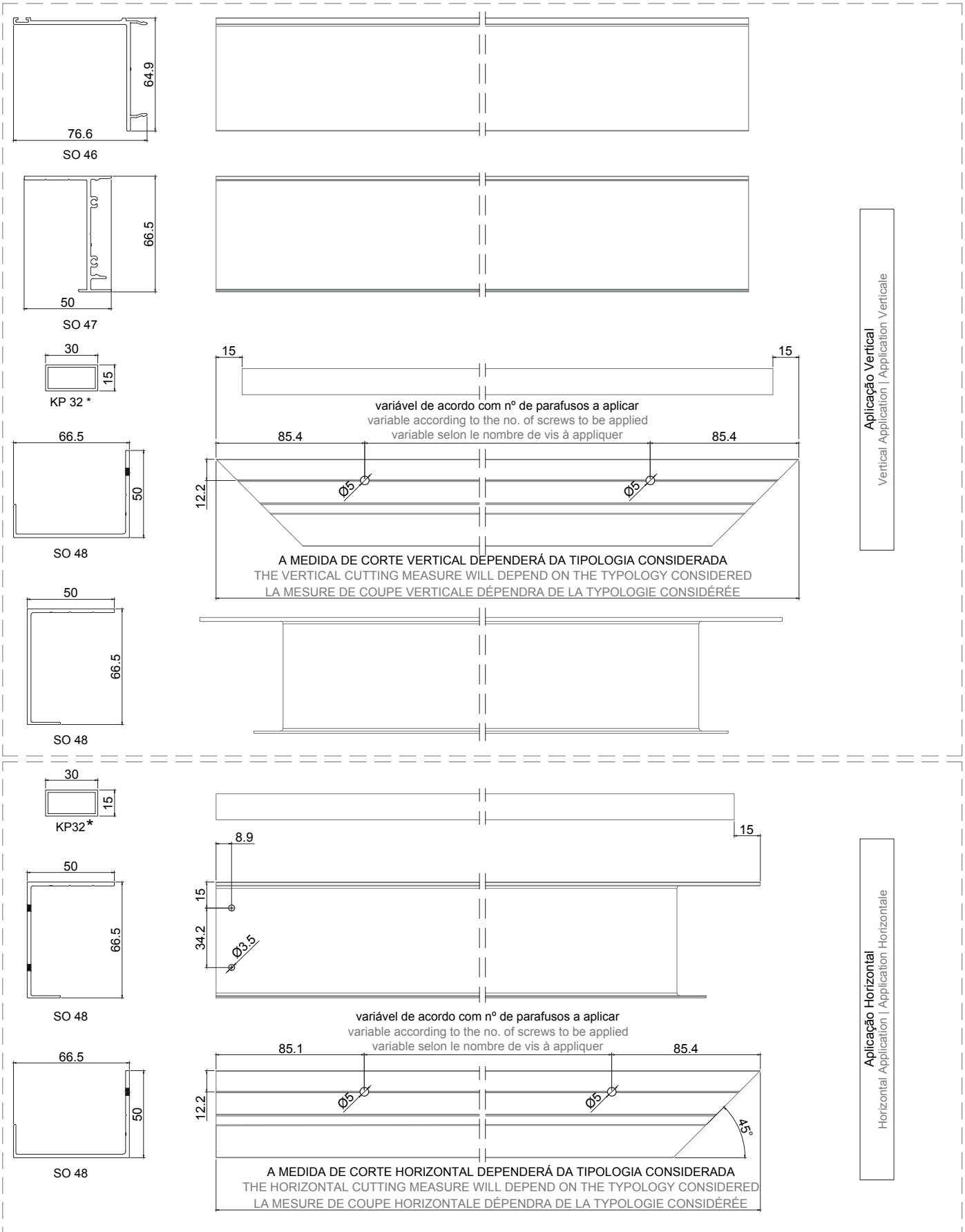

\* Considerar apenas em tipologias FR. | Consider only in FR typologies. | À considérer uniquement dans les typologies FR.

**MONTAGEM DE TIPOLOGIAS DE EMBUTIR**  
HIDDEN SLIDING TYPOLOGIES ASSEMBLY  
ASSEMBLAGE DE TYPOLOGIES À GALANDAGE

12 - Sequência de montagem.  
Assembly sequencyence.  
Séquence d'assemblage.

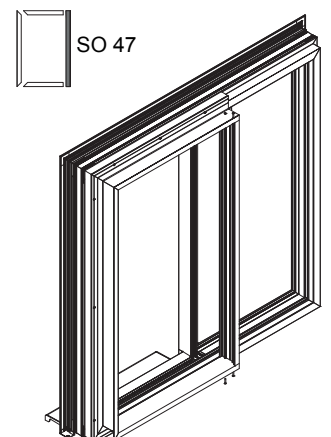
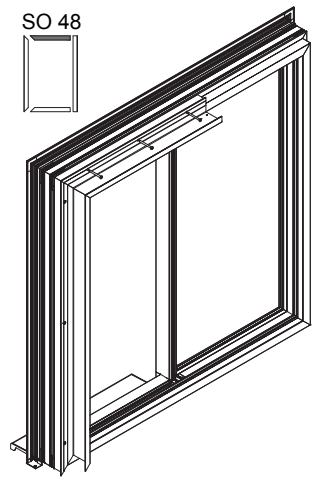
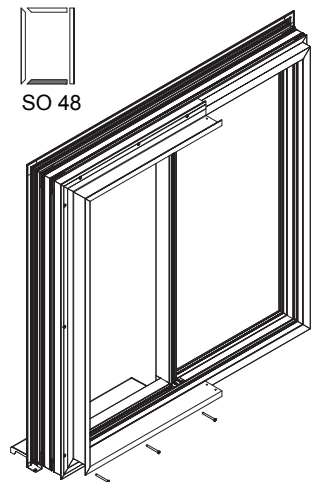
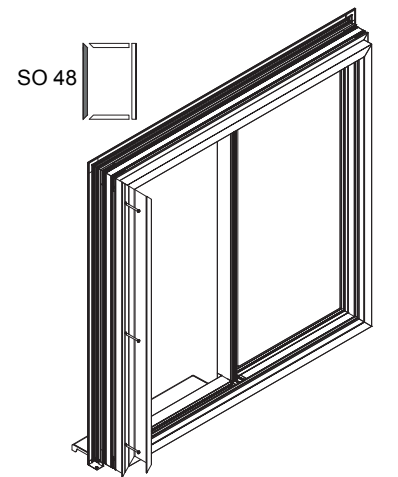
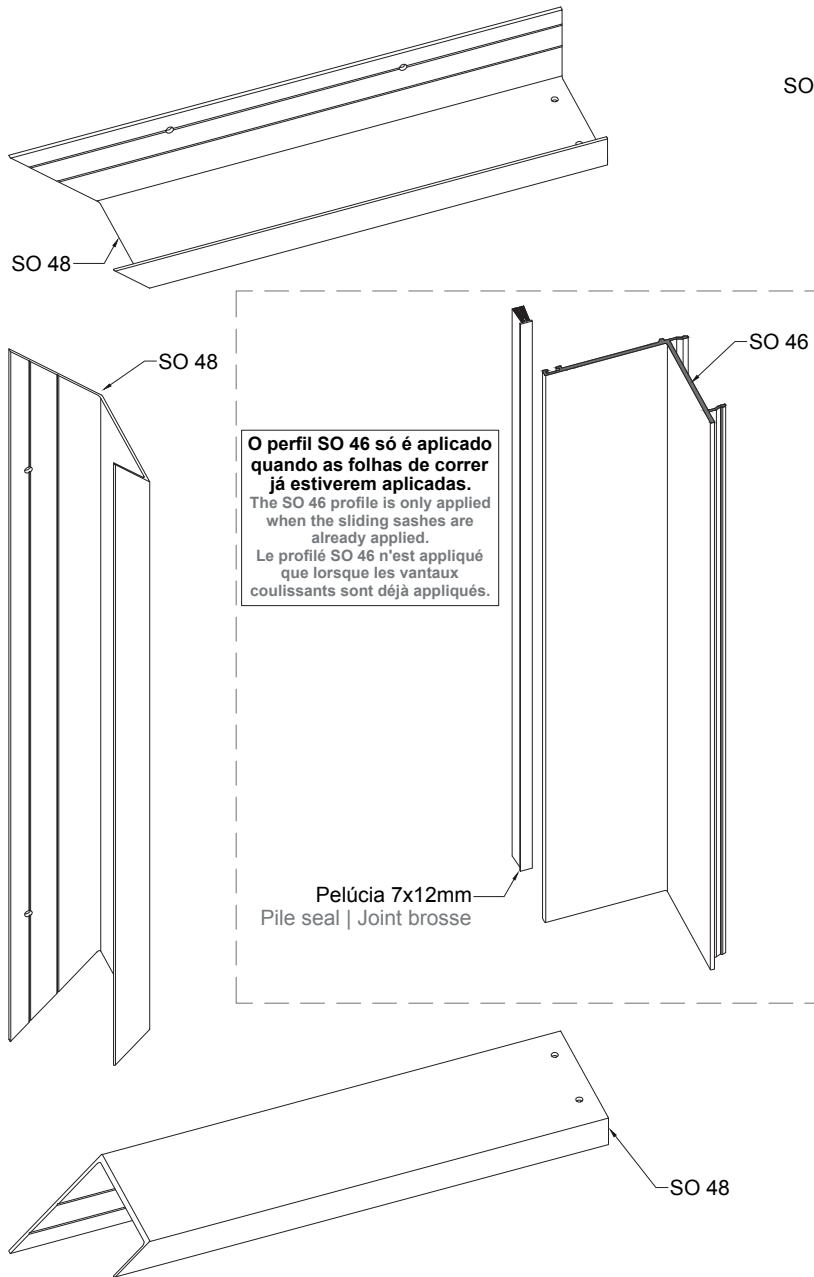

**MONTAGEM DOS PERFIS ARO MÓVEL JT**  
JT MOBILE FRAME PROFILES ASSEMBLY  
ASSEMBLAGE DES PROFILÉS OUVRANT JT

1 - Montagem do vidro.  
Glass assembly.  
Assemblage du verre.

1.1 - Corte dos cantos da junta de vidro U.  
U glazing gasket corners cutting.  
Couper de les coins du joint du verre U.

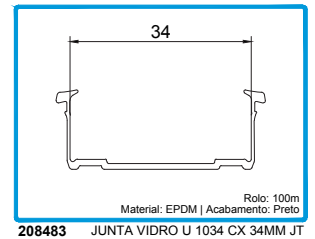
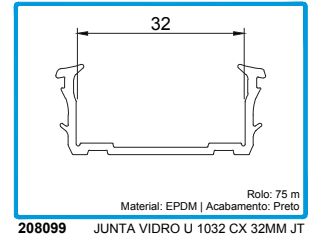
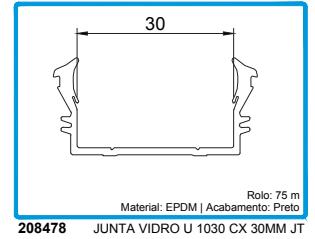
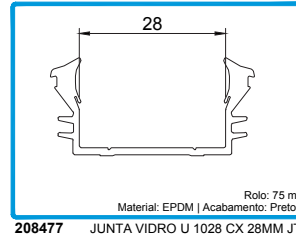
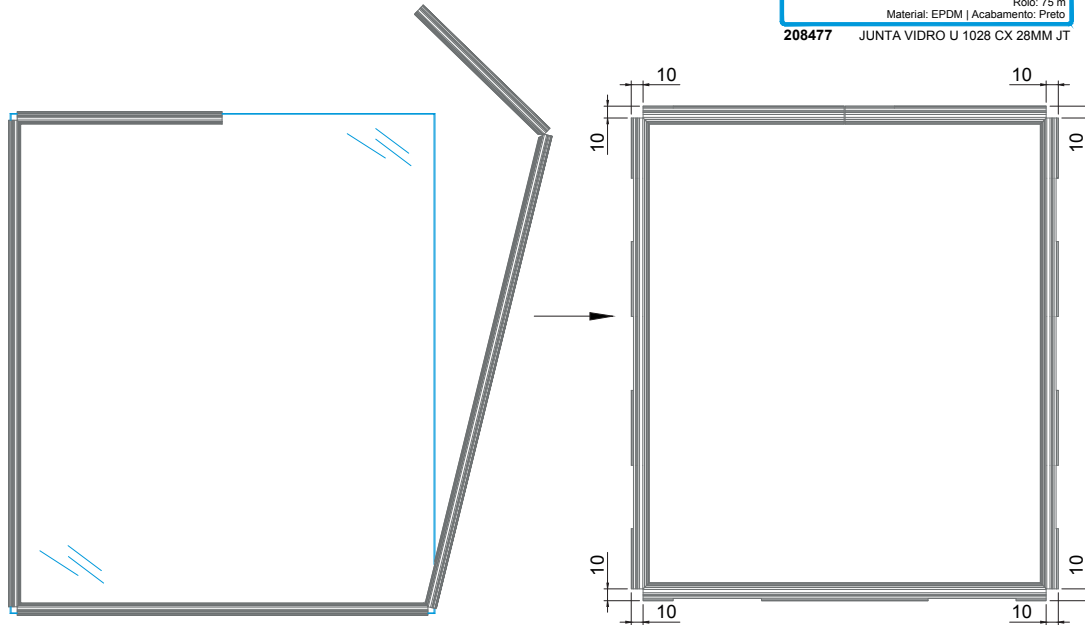

**IMPORTANTE | IMPORTANT | IMPORTANT:**  
As operações a efetuar na junta deverão ser feitas com esta já aplicada no vidro, mas antes de se colocarem os perfis de alumínio.  
The operations to be carried out on the joint must be done with it already applied in the glass, but before placing the aluminum profiles.  
Les opérations à effectuer sur le joint doivent être effectuées avec celui-ci déjà appliqué sur le verre, mais avant la pose des profilés en aluminium.

1.2 - Corte adicional da junta de vidro U para colocação de calços de reforço horizontal.  
U glazing gasket additional cutting for placing the reinforcement shims.  
Coupe supplémentaire du joint du verre U pour la mise en place des cales de renforcement horizontal.

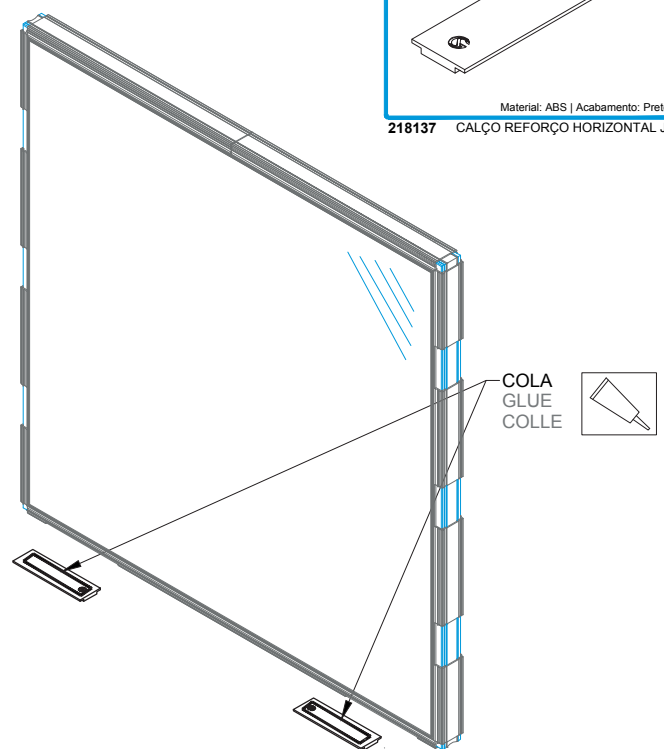
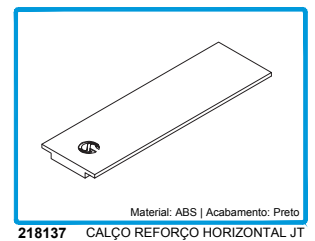
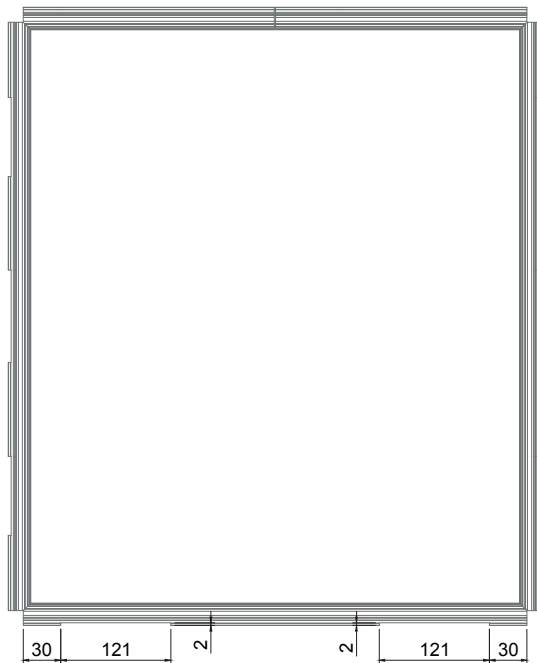

**IMPORTANTE | IMPORTANT | IMPORTANT:**  
Esta operação apenas será necessária em vidros com mais de 80Kg.  
This operation will only be necessary for glasses with more than 80Kg.  
Cette opération ne sera nécessaire que pour les verres de plus de 80Kg.



**MONTAGEM DOS PERFIS ARO MÓVEL JT**  
JT MOBILE FRAME PROFILES ASSEMBLY  
ASSEMBLAGE DES PROFILÉS OUVRANT JT

1 - Montagem do vidro.  
Glass assembly.  
Assemblage du verre.

1.3 - Corte da junta de vidro U e furação dos perfis laterais e centrais, para colagem estrutural do vidro.  
U glazing gasket cutting and drilling the lateral and central profiles, for structural bonding of the glass.  
Couper le joint de verre en U et percer les profilés latéraux et centraux pour le collage structurel du verre.

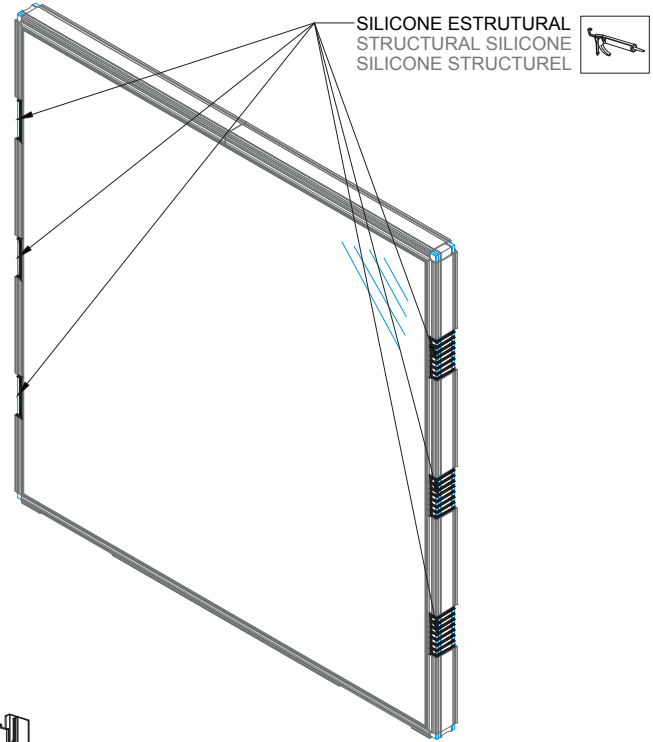
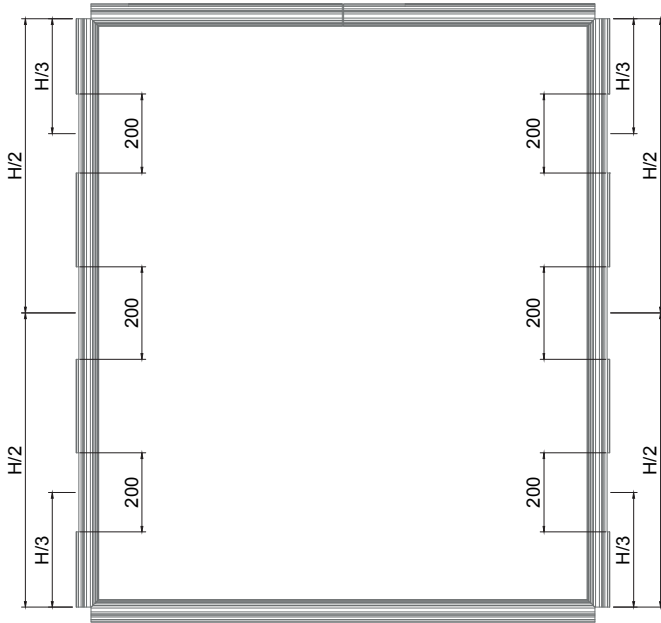

**IMPORTANTE | IMPORTANT | IMPORTANT:**  
Esta operação terá de ser feita em todos os vidros, H>1500mm.  
This operation must be done on all glasses, H>1500mm.  
Cette opération devra être effectuée sur toutes les verres, H>1500mm.

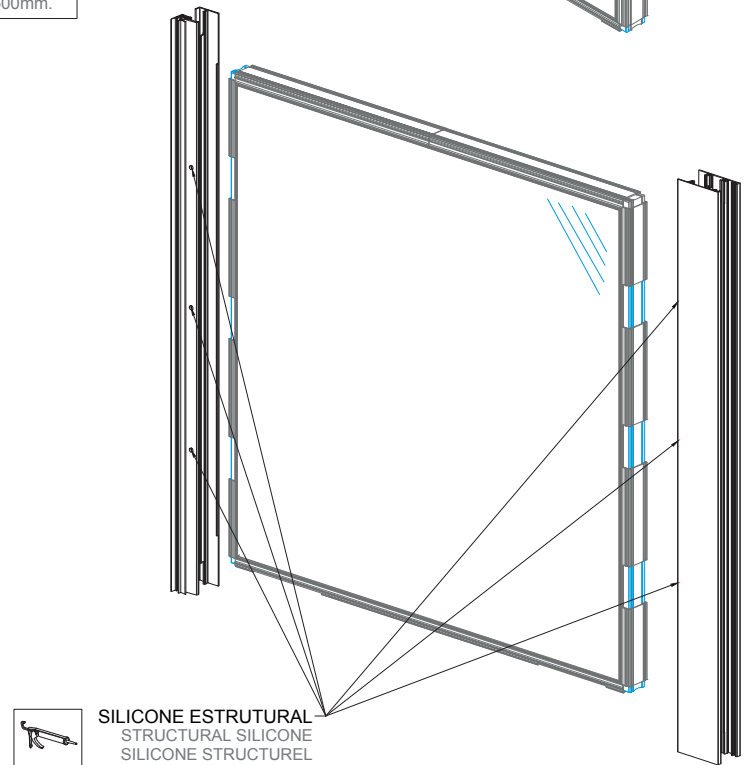
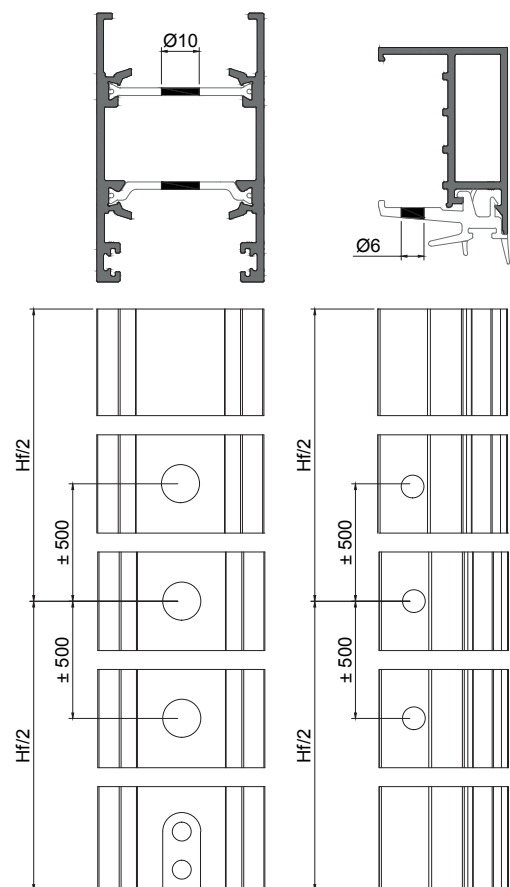

**IMPORTANTE | IMPORTANT | IMPORTANT:**  
Preencher na totalidade o espaço entre o vidro e o perfil com silicone estrutural. Estudar a capacidade de adesão perfil-vidro com o fornecedor de silicone estrutural.  
Completely fill the space between the glass and the profile with structural silicone. Study the profile-glass adhesion capacity with the structural silicone supplier.  
Remplir complètement l'espace entre le verre et le profilé avec du silicone structurel. Étudier la capacité d'adhésion profilé-verre avec le fournisseur de silicone structurel.

MONTAGEM DOS PERFIS ARO MÓVEL JT  
 JT MOBILE FRAME PROFILES ASSEMBLY  
 ASSEMBLAGE DES PROFILÉS OUVRANT JT

2 - Colocação dos carrinhos nas travessas inferiores.  
 Rollers placement on the bottom transoms.  
 Placement des roulettes sur les traverses inférieures.

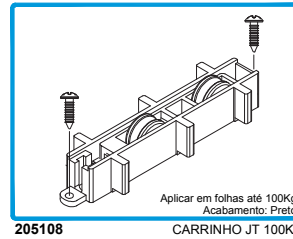

Aplicar em folhas até 100Kg  
 Acabamento: Preto

OU  
 OR | OU

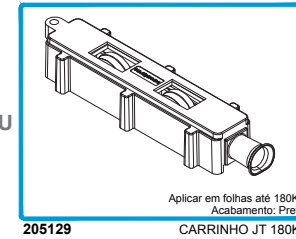

Aplicar em folhas até 180Kg  
 Acabamento: Preto

OU  
 OR | OU

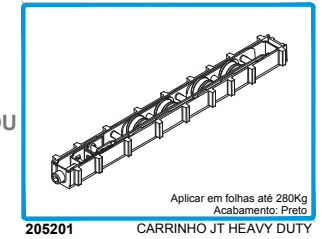

Aplicar em folhas até 280Kg  
 Acabamento: Preto

2 mm  
 Para afinação do carrinho  
 For roller tuning | Pour le réglage du chariot

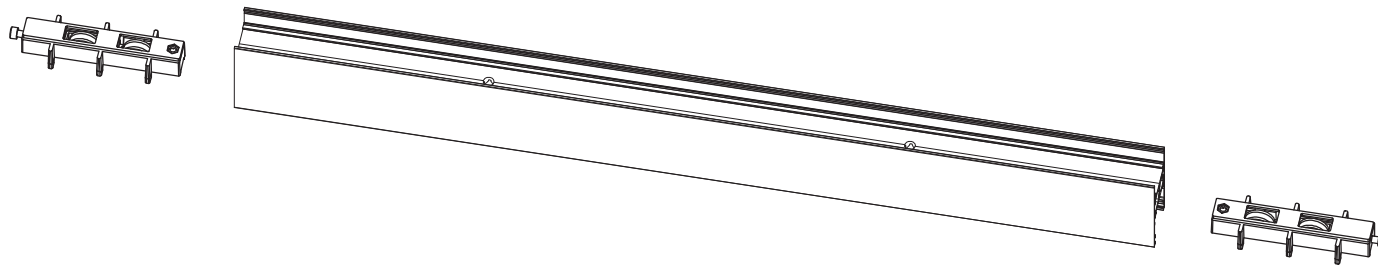
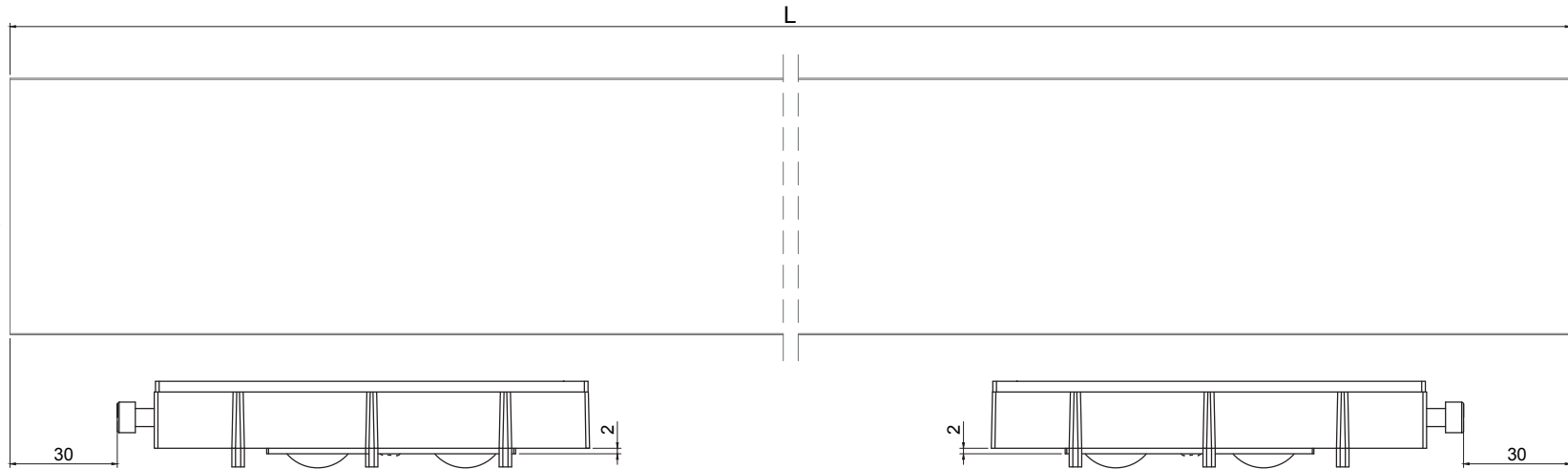

**IMPORTANTE | IMPORTANT | IMPORTANT:**  
 Os carrinhos devem ser aplicados nas travessas inferiores antes de fechar o aro móvel.  
 The rollers must be applied on the lower transoms before closing the mobile frame.  
 Les roulettes doivent être appliqués sur les traverses inférieures avant de fermer le cadre ouvrant.

## MONTAGEM DOS PERFIS ARO MÓVEL JT

JT MOBILE FRAME PROFILES ASSEMBLY

ASSEMBLAGE DES PROFILÉS OUVRANT JT

### 3 - Montagem e fixação do aro móvel.

Mobile frame assembling and fixing.

Montage et fixation de le cadre ouvrant.

#### 3.1 - Colar as pelúcias nos topos laterais e centrais, antes de os colocar nos perfis.

Glue the pile seals of the lateral and central end-caps before placing them in the profiles.

Coller les joint brosses sur les embouts latéraux et centraux avant de les placer sur les profilés.

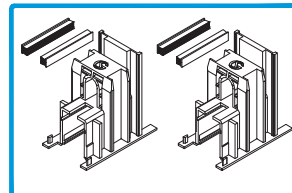

212199 CONJ. TOPOS LAT. JT N°1  
Para os perfis JT 61, 62, 64, 65, 66, 67 e 68  
Material: Poliamida | Acabamento: Preto

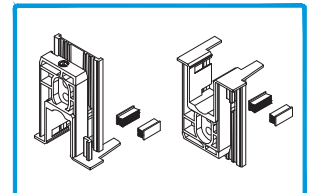

212231 CONJ. TOPOS CENTRAIS JT  
Para os perfis JT 51, 52, 53 e 54  
Material: Poliamida | Acabamento: Preto

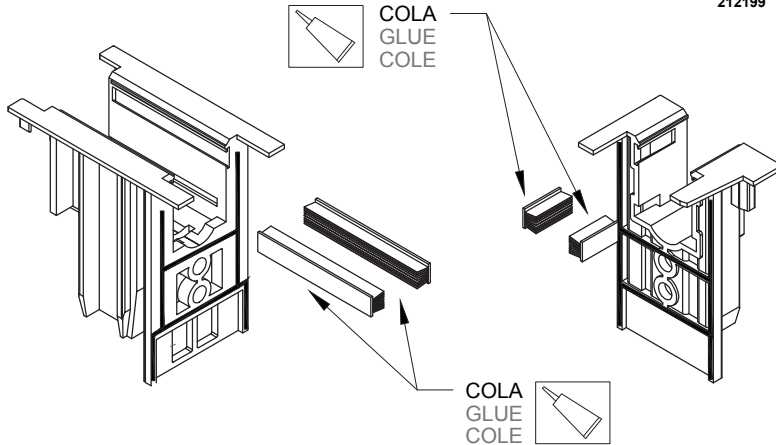

#### 3.2 - Colar as peças de poliamida ao perfil móvel, para aplicação de ferragens multiponto.

Glue the polyamide parts to the mobile profile, for application of multipoint hardware.

Coller les pièces en polyamide sur le profilé mobile, pour l'application de la serrure multipoint.

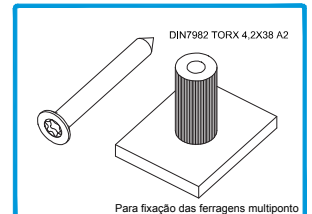

212371 CONJ. FIXAÇÃO JT  
Para fixação das ferragens multiponto

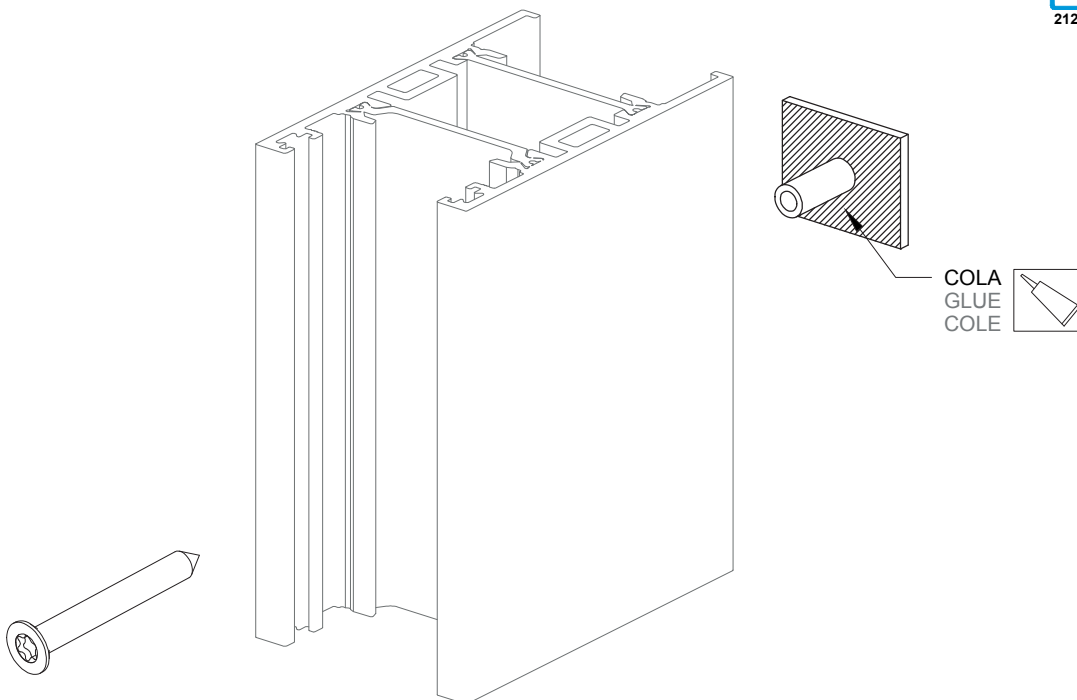

**MONTAGEM DOS PERFIS ARO MÓVEL JT**  
JT MOBILE FRAME PROFILES ASSEMBLY  
ASSEMBLAGE DES PROFILÉS OUVRANT JT

**3 - Montagem e fixação do aro móvel.**

Mobile frame assembling and fixing.

Montage et fixation de le cadre ouvrant.

**3.3 - Aplicar silicone nas zonas de sobreposição dos perfis móveis verticais/horizontais e nos topos de fixação.**

Apply silicone in the overlapping areas of the vertical/horizontal mobile profiles and in the fixing end-caps.

Appliquer du silicone sur les zones de chevauchement des profilés ouvrant verticaux/horizontaux et des embouts de fixation.

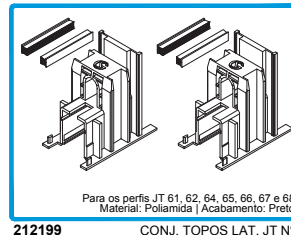

212199

CONJ. TOPOS LAT. JT N°1

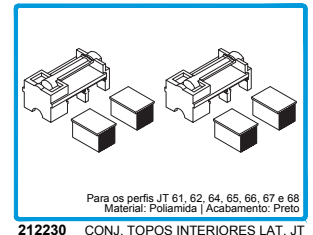

212230

CONJ. TOPOS INTERIORES LAT. JT

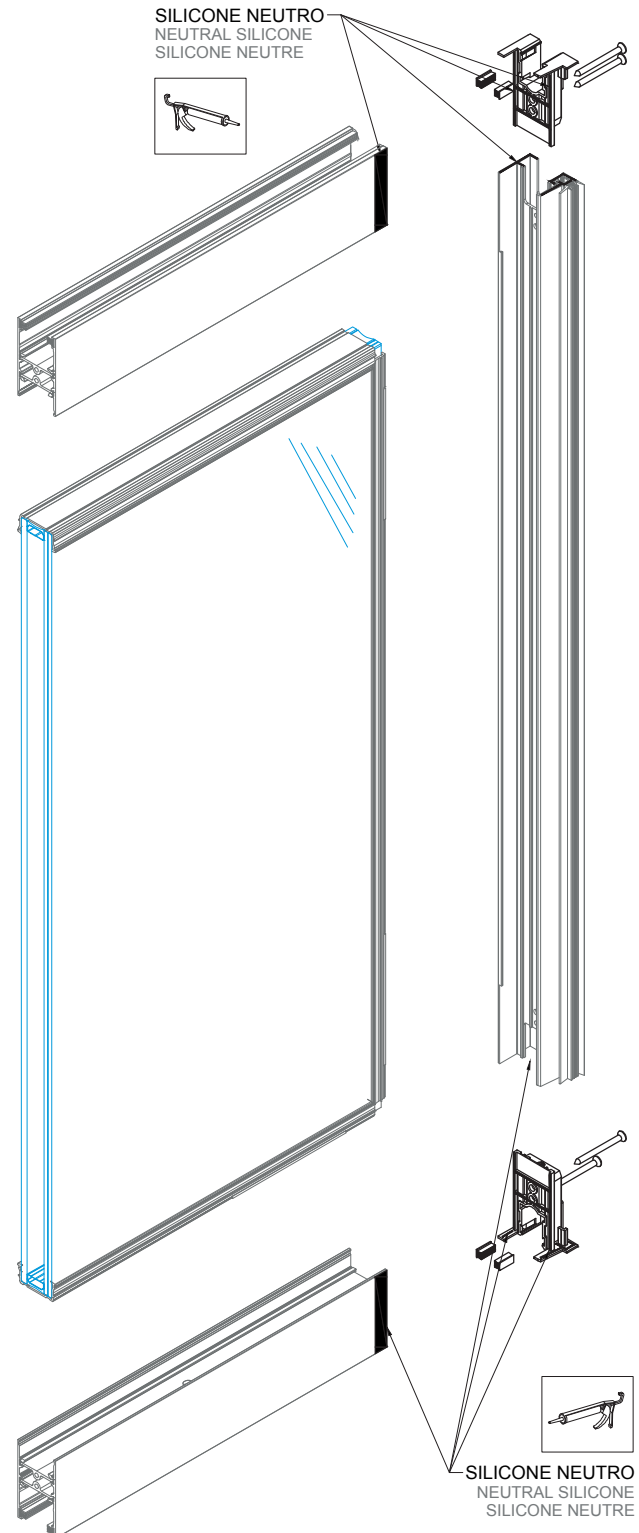
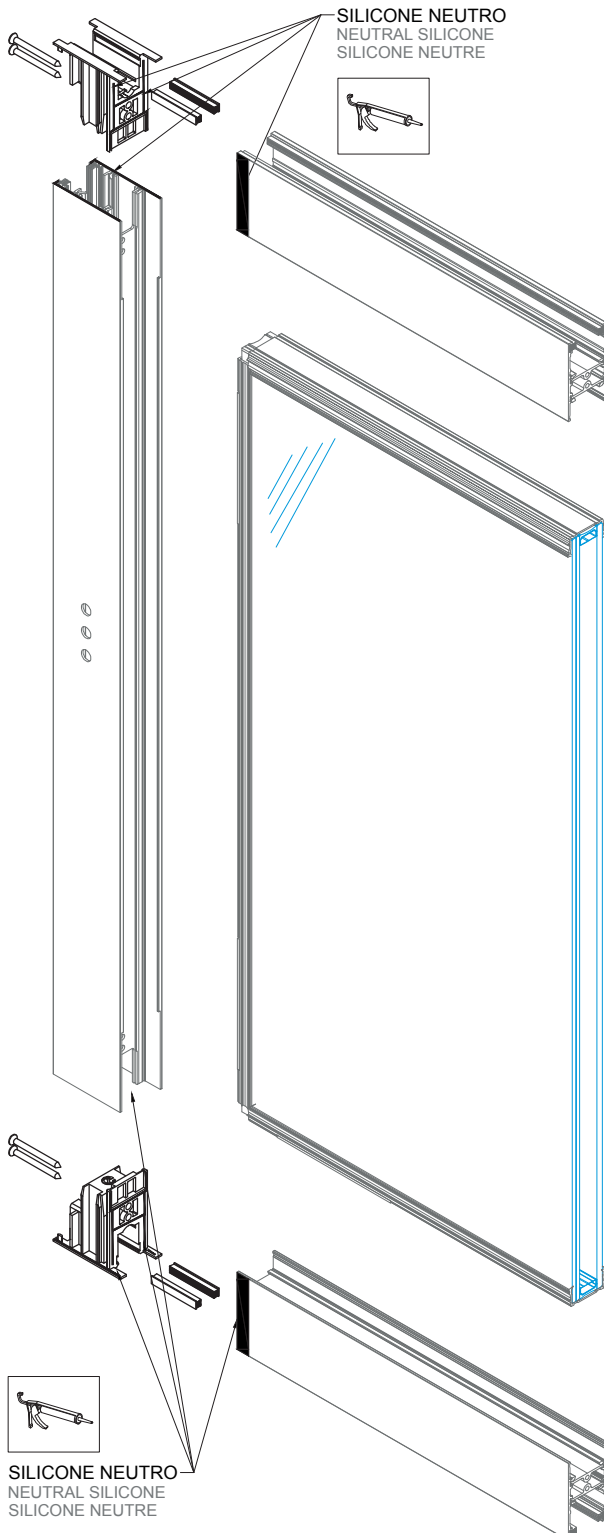

**MONTAGEM DOS PERFIS ARO MÓVEL JT**  
JT MOBILE FRAME PROFILES ASSEMBLY  
ASSEMBLAGE DES PROFILÉS OUVRANT JT

**3 - Montagem e fixação do aro móvel.**

Mobile frame assembling and fixing.  
Montage et fixation de le cadre ouvrant.

**3.4 - Etapas de montagem.**

Assembly steps.  
Étapes d'assemblage.

**Passo | Step | Étape 1:**

**Colocar as travessas inferior e superior no vidro**

Place the upper and lower transoms on the glass  
Placer les traverses supérieure et inférieure sur le verre

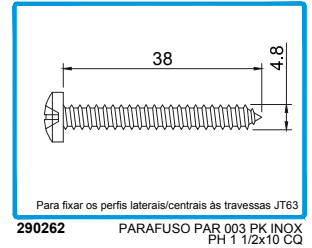
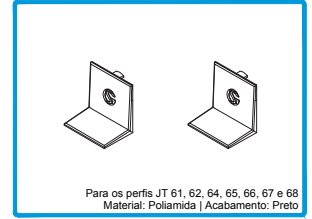
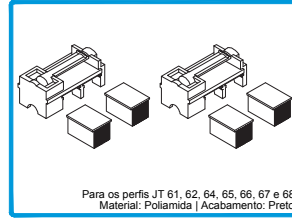
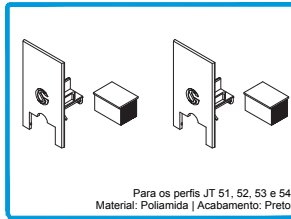

**Passo | Step | Étape 2:**

**Colocar o perfil lateral juntamente com os topos e encaixar nas travessas**

Place the lateral profile together with the end-caps and fit it on the transoms  
Placer le profilé latéral avec les embouts et monter sur les traverses

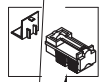
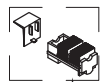

Estes acessórios deverão ser colocados quando a folha já estiver aplicada no vão.  
These accessories should be placed when the sash is already applied in the frame.  
Ces accessoires doivent être placés lorsque la vantail est déjà appliquée sur le cadre.

**Passo | Step | Étape 3:**

**Colocar o perfil central com os topos e encaixar nas travessas.**

Place the central profile with the end-caps and fit in the transoms.  
Placer le profilé central avec les embouts et placer sur les traverses.

Estes acessórios deverão ser colocados quando a folha já estiver aplicada no vão.  
These accessories should be placed when the sash is already applied in the frame.  
Ces accessoires doivent être placés lorsque la vantail est déjà appliquée sur le cadre.

**Passo | Step | Étape 4:**

**Fixar os perfis através do aparafusamento dos topos.**

Fix the profiles by screwing the end-caps.  
Fixer les profilés en vissant les embouts.

**MONTAGEM DOS PERFIS ARO MÓVEL JT**  
JT MOBILE FRAME PROFILES ASSEMBLY  
ASSEMBLAGE DES PROFILÉS OUVRANT JT

**4 - Perfis móveis laterais.**

Lateral mobile profiles.  
Profils ouvrants latéraux.

**4.1 - Os topos JT64/JT65 N°1 e N°2 devem ser aplicados conforme a referência e fresagem do perfil:**

The end-caps that constitute the JT64/JT65 Lateral End-caps Kit must be applied according to the profile's reference and milling:

Les embouts qui composent le Kit d'embouts latéraux JT64/JT65 doivent être appliqués selon la référence et le fraisage du profilé:

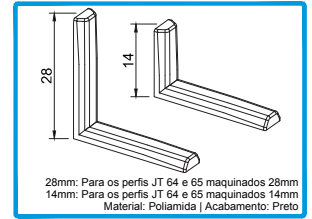

**210239** TOPO JT64/JT65 28MM  
**210240** TOPO JT64/JT65 14MM

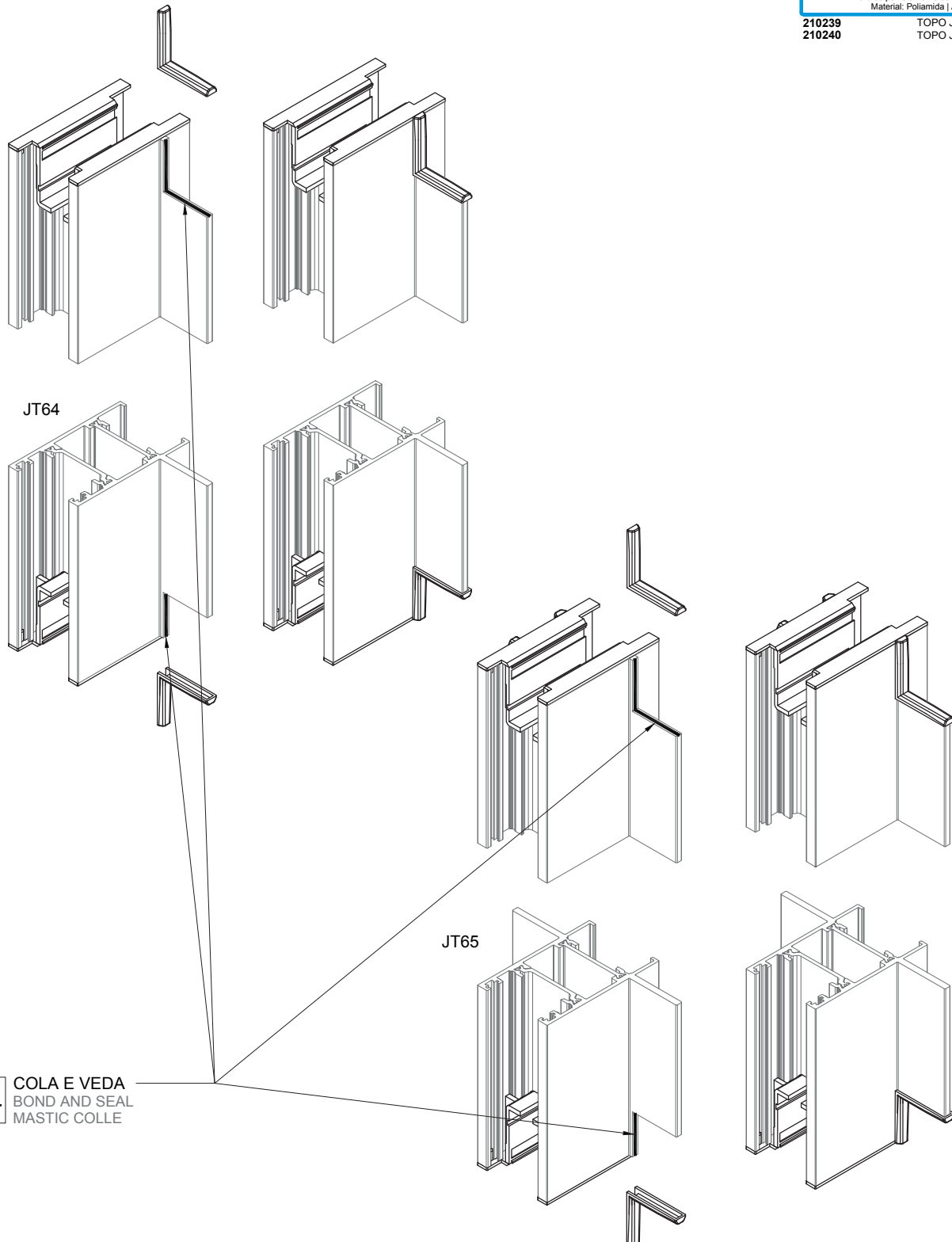

**MONTAGEM DOS PERFIS ARO MÓVEL JT**  
JT MOBILE FRAME PROFILES ASSEMBLY  
ASSEMBLAGE DES PROFILÉS OUVRANT JT

**4 - Perfis móveis laterais.**

Lateral mobile profiles.  
Profils ouvrants latéraux.

**4.2 - Os topos que constituem o Conjunto de Topos Laterais JT68 e/ou devem ser aplicados conforme a referência e fresagem do perfil:**

The end-caps that constitute the JT68 Lateral End-caps Kit must be applied according to the profile's reference and milling:

Les embouts qui composent le Kit d'embouts latéraux JT68 doivent être appliqués selon la référence et le fraisage du profilé:

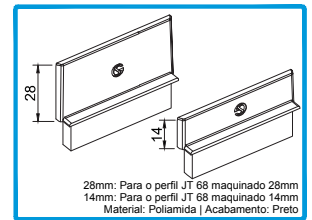

**210288**  
**210289**

**TOPO LATERAL JT68 28MM**  
**TOPO LATERAL JT68 14MM**

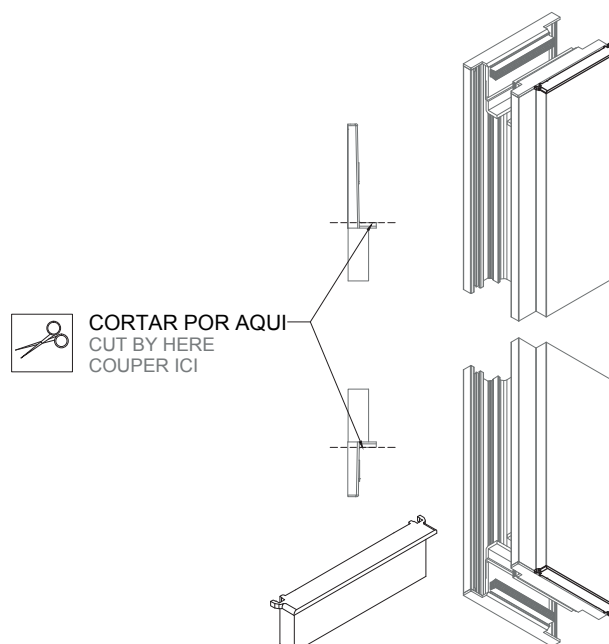
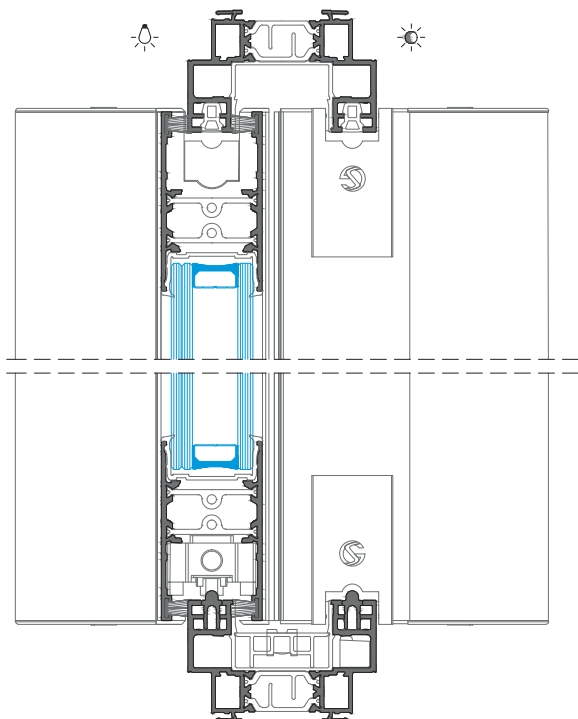
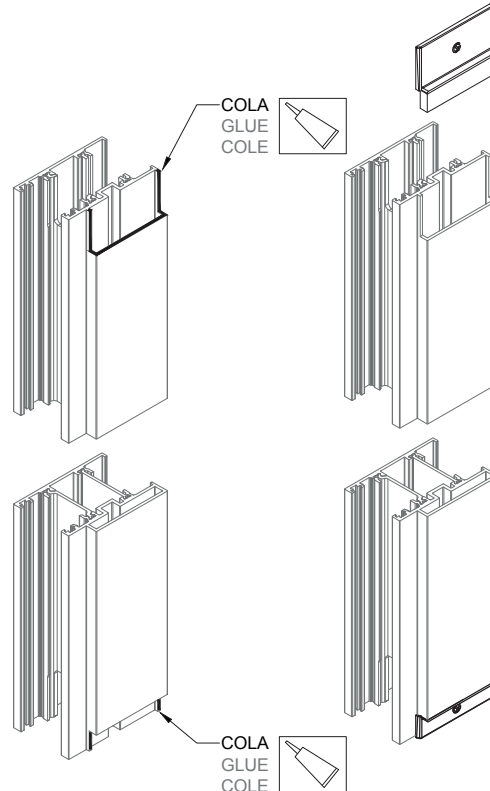
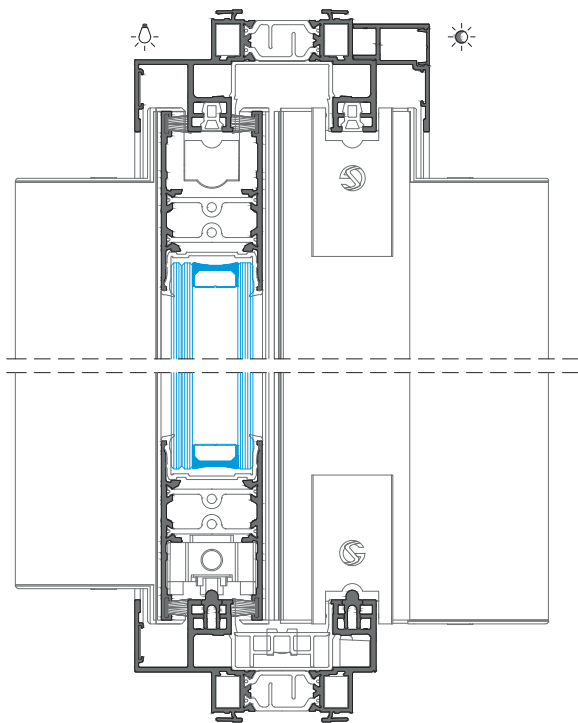



## MONTAGEM DOS PERFIS ARO MÓVEL JT

JT MOBILE FRAME PROFILES ASSEMBLY

ASSEMBLAGE DES PROFILÉS OUVRANT JT

### 5 - Perfis móveis centrais.

Central mobile profiles.

Profils ouvrants centraux.

Os topos que constituem o Conjunto de Topos Centrais devem ser aplicados conforme a referência e frezagem do perfil:

The end-caps that constitute the Central End-caps Kit must be applied according to the profile's reference and milling:

Les embouts qui composent le Kit d'embouts centraux doivent être appliqués selon la référence et le fraisage du profilé:

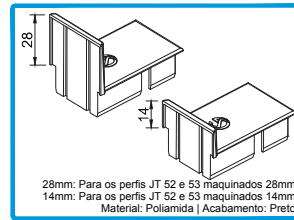

**210241** TOPO CENTRAL REFORÇADO 28MM  
**210242** TOPO CENTRAL REFORÇADO 14MM

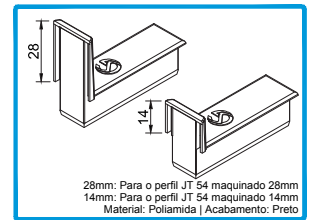

**210243** TOPO CENTRAL REFORÇ. JT54 28MM  
**210244** TOPO CENTRAL REFORÇ. JT54 14MM

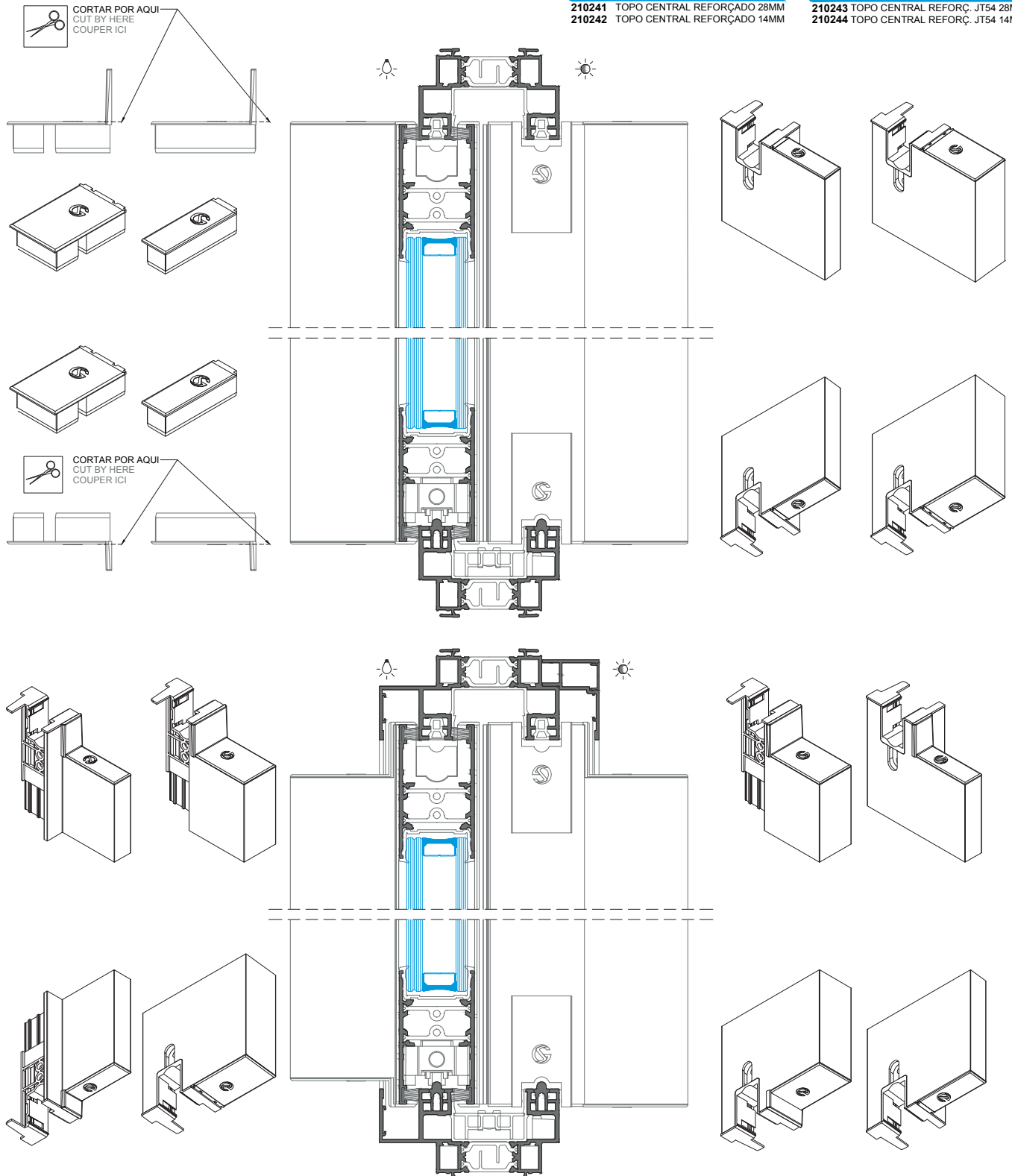

**MONTAGEM DOS PERFIS ARO MÓVEL JT**  
JT MOBILE FRAME PROFILES ASSEMBLY  
ASSEMBLAGE DES PROFILÉS OUVRANT JT

6 - Montagem de tipologia de canto 90° - **FOLHA A.**  
Assembly of 90° corner typology - **A SASH.**  
Assemblage d'une typologie d'angle à 90° - **VANTAIL A.**

6.1 - Fixação dos perfis JT62 e JT72.  
JT62 and JT72 fixation.  
Fixation des profilés JT62 et JT72.

FOLHA | SASH | VANTAIL A

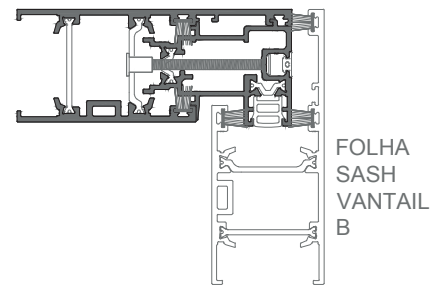

**IMPORTANTE | IMPORTANT | IMPORTANT:**  
Colocar os rebites antes de se fazer o fecho das esquadrias da folha móvel.  
**Utilizar no mínimo 4 conjuntos para fixação do perfil JT72.**  
Place the rivets before closing the frames of the mobile sash.  
**Use at least 4 sets for fixing the JT72 profile.**  
Placer les rivets avant de fermer les cadres de la cadre ouvrant.  
**Utiliser au moins 4 kit pour la fixation du profilé JT72.**

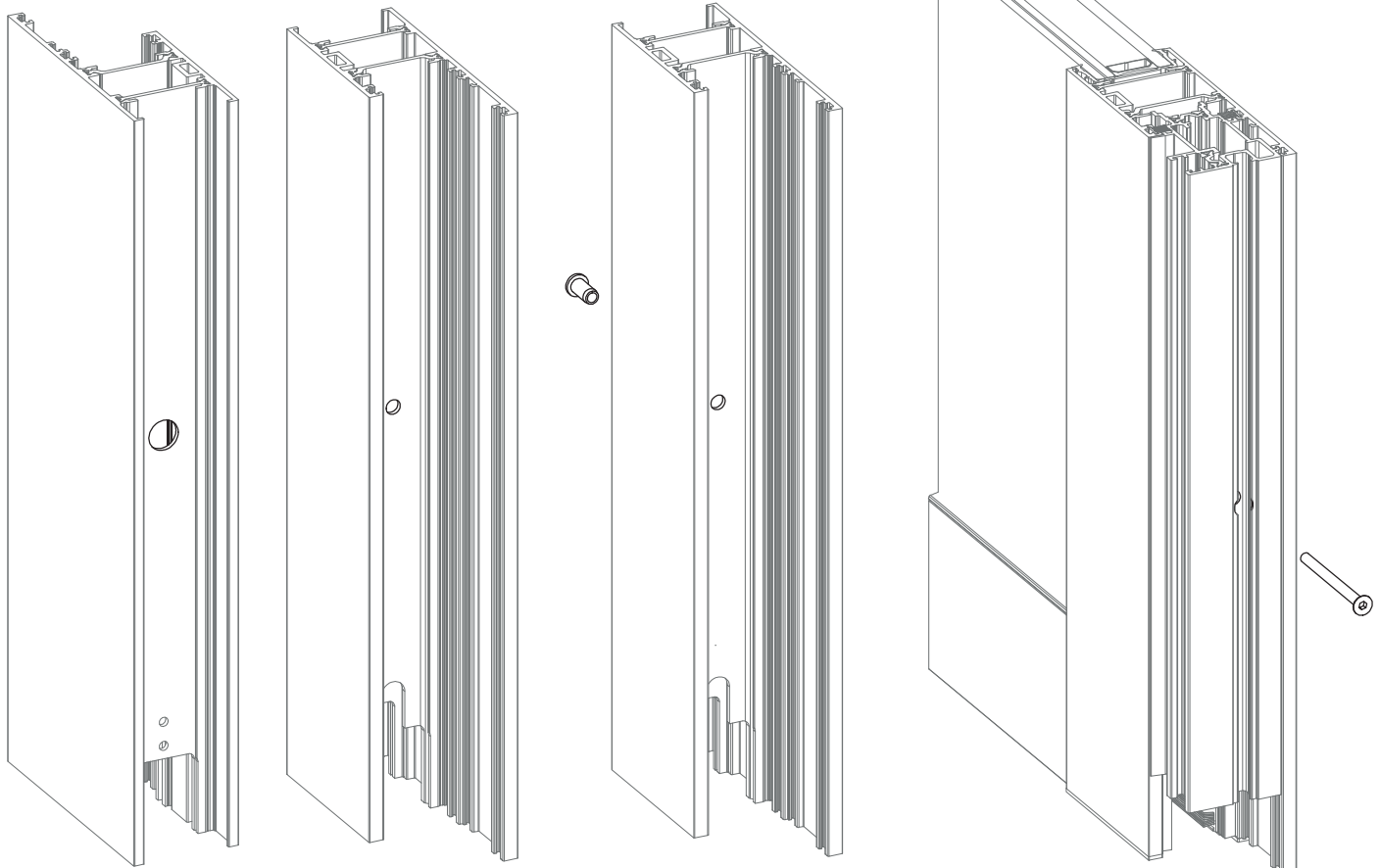
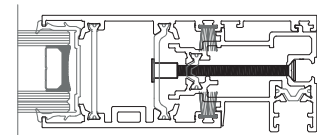
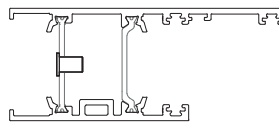
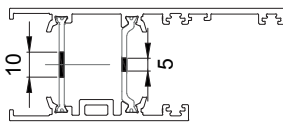
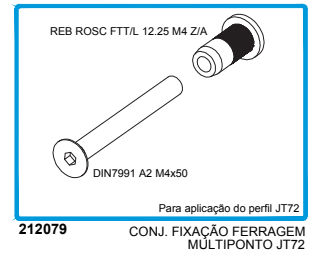

## MONTAGEM DOS PERFIS ARO MÓVEL JT

JT MOBILE FRAME PROFILES ASSEMBLY

ASSEMBLAGE DES PROFILÉS OUVRANT JT

6 - Montagem de tipologia de canto 90° - **FOLHA A.**

Assembly of 90° corner typology - **A SASH.**

Assemblage d'une typologie d'angle à 90° - **VANTAIL A.**

6.2 - Posicionar os calços para contra-fecho antes de se colocar a folha no vão.

Fit the locking plate shims before placing the sash in the frame.

Positionner les cales pour la contre-fermeture avant de placer le vantail dans le cadre.

FOLHA | SASH | VANTAIL A

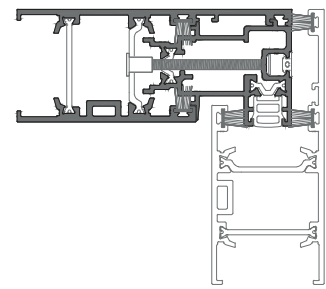

FOLHA  
SASH  
VANTAIL  
B

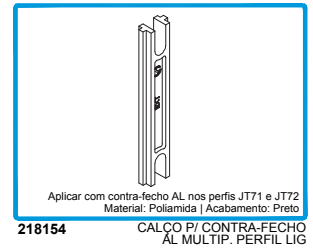
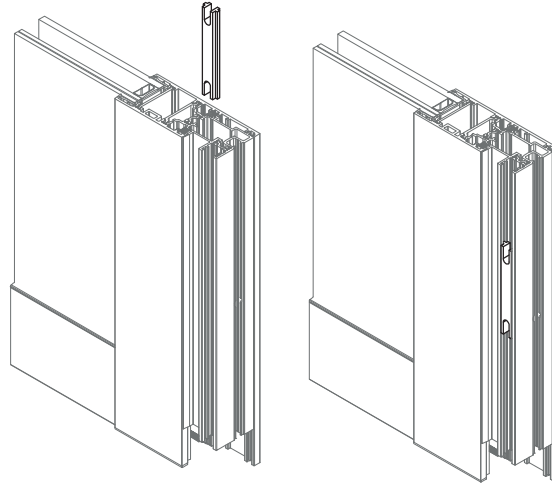
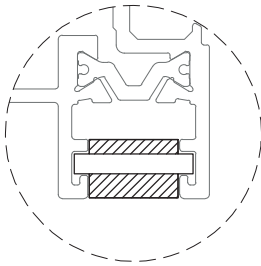
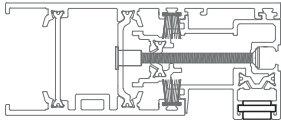

Este passo só se efetua quando se usa a ferragem multiponto SOS.

This step is only performed when using SOS multipoint hardware.

Cette étape n'est effectuée que lors de l'utilisation de serrure multipoint SOS.

6.3 - Colocar os contras-ferchos na posição final.

Place the locking plates in its final position.

Placer les contre-fermeture en position finale.

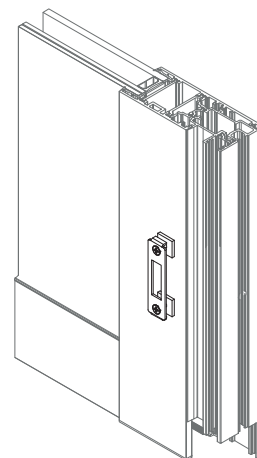
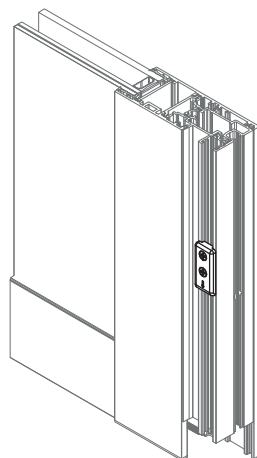
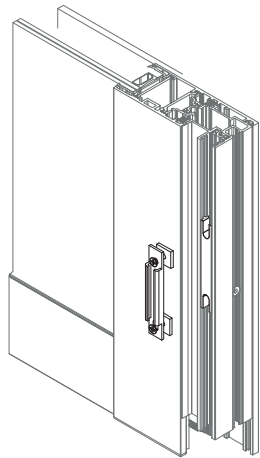
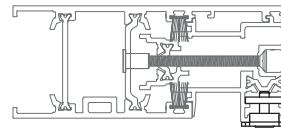
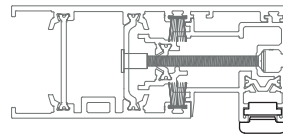
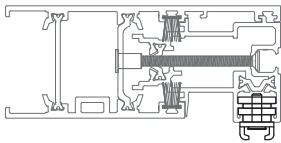

**FERRAGEM MULTIPONTO**  
MULTIPOINT HARDWARE  
SERRURE MULTIPOINT  
SOS

**FERRAGEM MULTIPONTO**  
MULTIPOINT HARDWARE  
SERRURE MULTIPOINT  
SOT

**FERRAGEM MULTIPONTO**  
MULTIPOINT HARDWARE  
SERRURE MULTIPOINT  
ALU

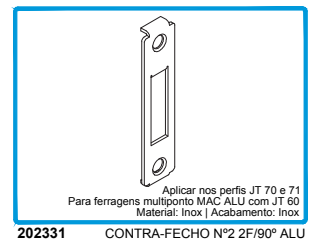
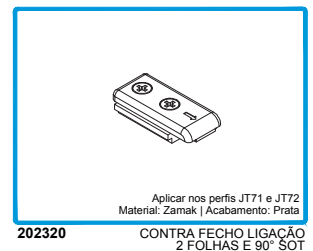
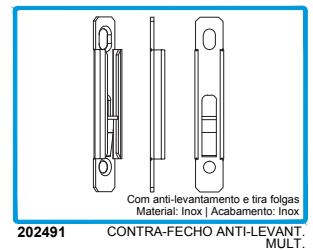
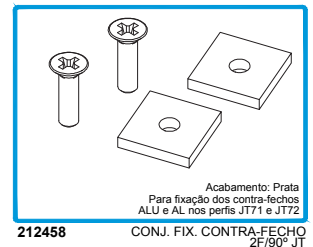

**MONTAGEM DOS PERFIS ARO MÓVEL JT**  
JT MOBILE FRAME PROFILES ASSEMBLY  
ASSEMBLAGE DES PROFILÉS OUVRANT JT

6 - Montagem de tipologia de canto 90° - **FOLHA A.**  
Assembly of 90° corner typology - **A SASH.**  
Assemblage d'une typologie d'angle à 90° - **VANTAIL A.**

6.4 - Colocar a folha no vão.  
Place the sash in the frame.  
Placer la vantail dans le cadre.

FOLHA | SASH | VANTAIL A

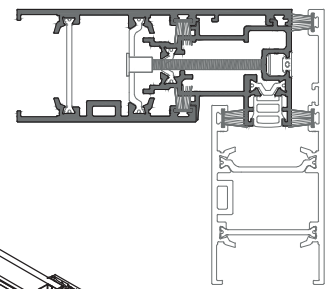

FOLHA  
SASH  
VANTAIL  
B

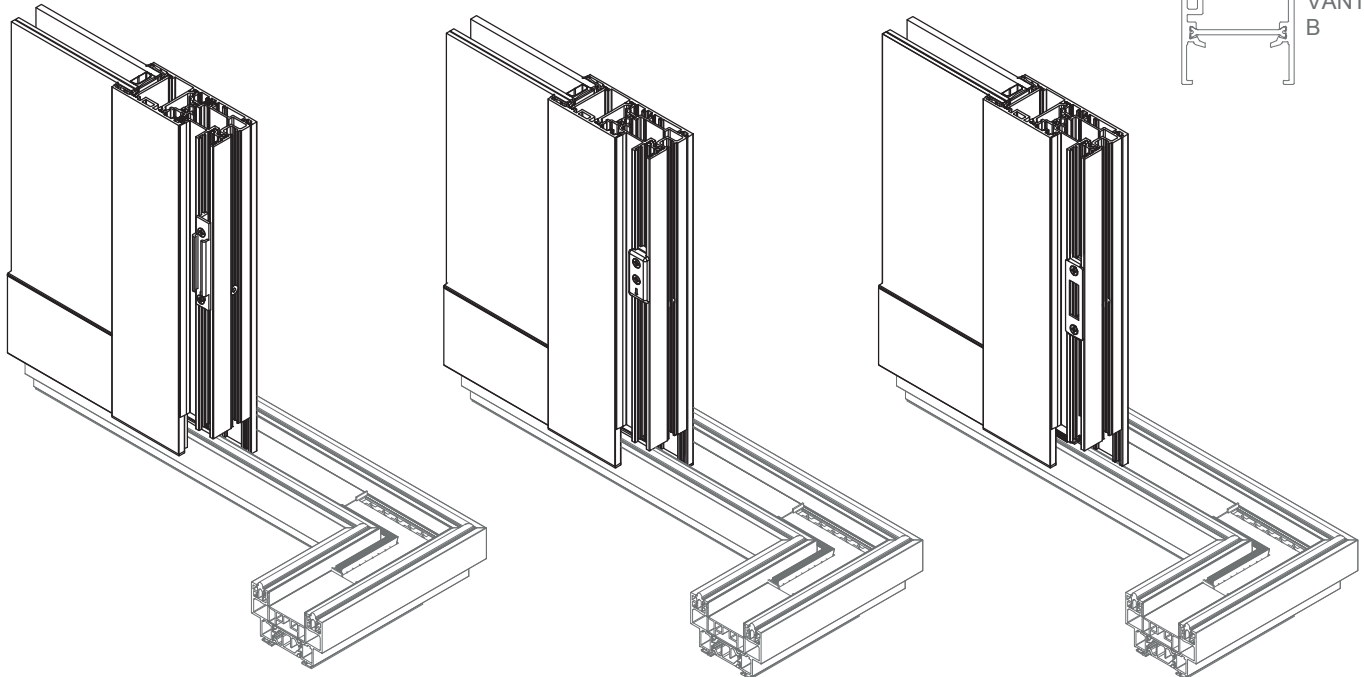

**FERRAGEM MULTIPONTO**  
MULTIPOINT HARDWARE  
SERRURE MULTIPOINT  
**SOS**

**FERRAGEM MULTIPONTO**  
MULTIPOINT HARDWARE  
SERRURE MULTIPOINT  
**SOT**

**FERRAGEM MULTIPONTO**  
MULTIPOINT HARDWARE  
SERRURE MULTIPOINT  
**ALU**

6.5 - Colocar o conjunto topos canto 90° JT.  
Place the 90° corner end-caps kit.  
Placer le kit d'embouts pour angle 90°.

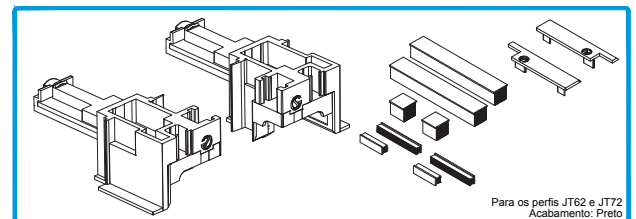

212109

Para os perfis JT62 e JT72  
Acabamento: Preto  
CONJ. TOPOS CANTO 90° JT

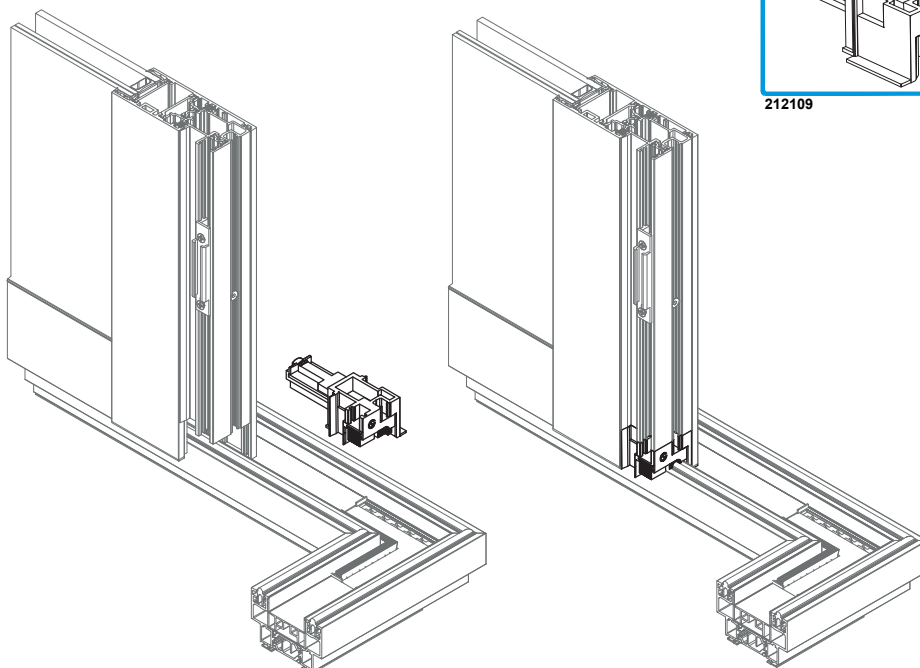

**MONTAGEM DOS PERFIS ARO MÓVEL JT**  
JT MOBILE FRAME PROFILES ASSEMBLY  
ASSEMBLAGE DES PROFILÉS OUVRANT JT

6 - Montagem de tipologia de canto 90° - **FOLHA A.**  
Assembly of 90° corner typology - **A SASH.**  
Assemblage d'une typologie d'angle à 90° - **VANTAIL A.**

6.6 - Colocar a junta tapa canal perfil lig. 2117 JT.  
Place the 2117 channel cover joint.  
Monter le joint de couvercle de canal du profilé de liaison 2117 JT.

FOLHA | SASH | VANTAIL A

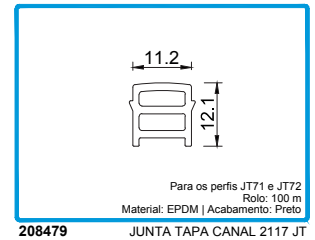
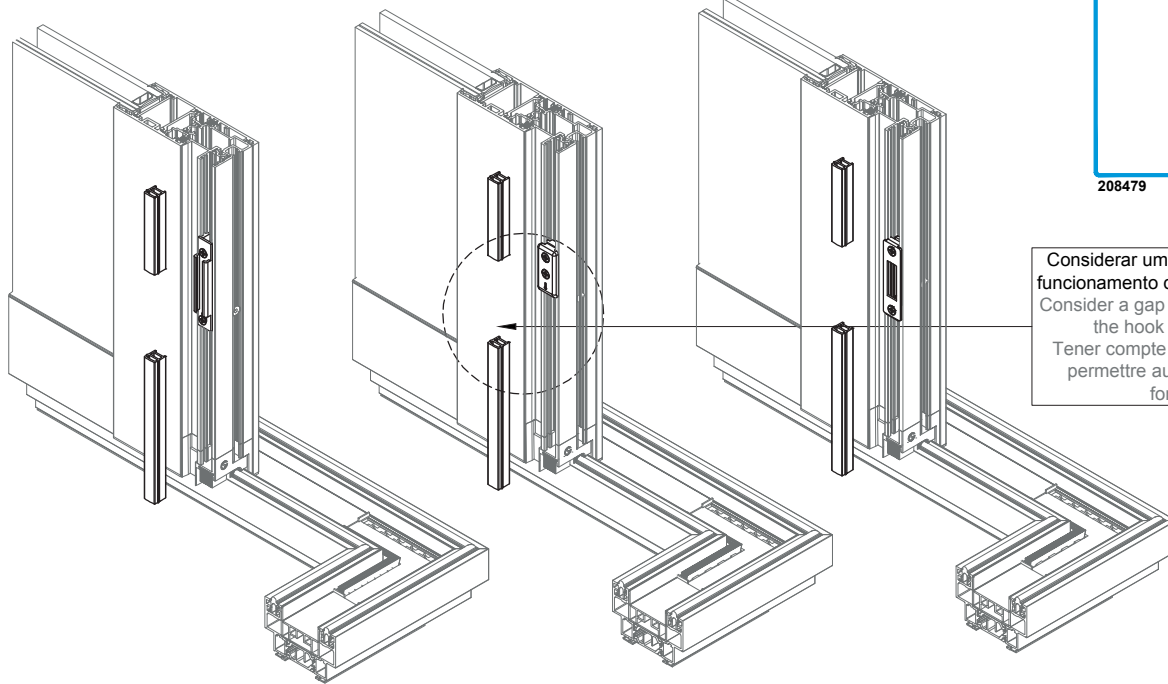
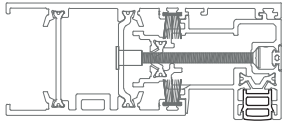
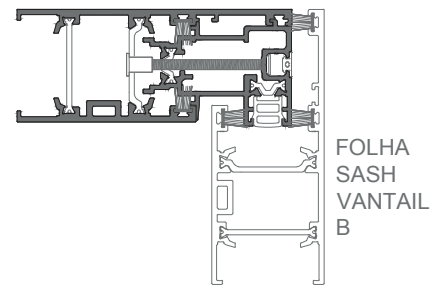

Considerar uma folga para permitir o funcionamento do gancho da ferragem.  
Consider a gap to allow the function of the hook of the hardware.  
Tener compte du dégagement pour permettre au crochet serrure de fonctionner.

**FERRAGEM MULTIPONTO**  
MULTIPOINT HARDWARE  
SERRURE MULTIPONT  
**SOS**

**FERRAGEM MULTIPONTO**  
MULTIPOINT HARDWARE  
SERRURE MULTIPONT  
**SOT**

**FERRAGEM MULTIPONTO**  
MULTIPOINT HARDWARE  
SERRURE MULTIPONT  
**ALU**

6.7 - Colocar a junta VD 2415.  
Place the VD 2415 joint.  
Placer le joint VD 2415.

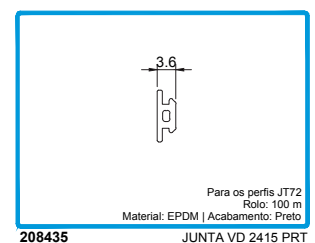
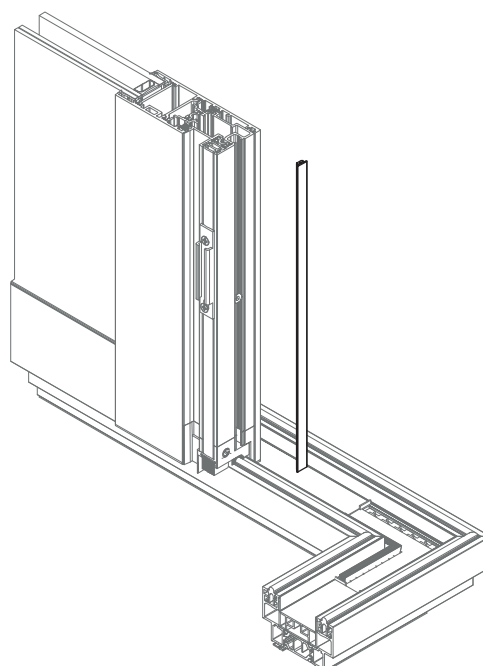
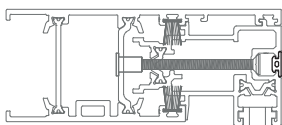

**MONTAGEM DOS PERFIS ARO MÓVEL JT**  
JT MOBILE FRAME PROFILES ASSEMBLY  
ASSEMBLAGE DES PROFILÉS OUVRANT JT

**7 - Montagem de tipologia de canto 90° - FOLHA B.**

Assembly of 90° corner typology - **B SASH.**

Assemblage d'une typologie d'angle à 90° - **VANTAIL B.**

**7.1 - Colar os topos que sobraram do Conjunto de topos canto 90° JT.**

Paste the remaining end-caps from the 90° corner end-caps kit.

Coller les embouts restants du kit d'embouts pour angle 90° JT.

FOLHA | SASH | VANTAIL A

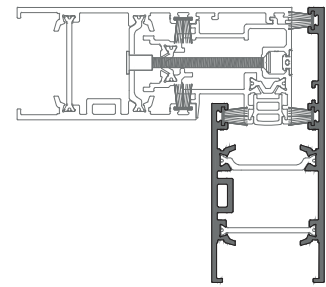

FOLHA  
SASH  
VANTAIL  
B

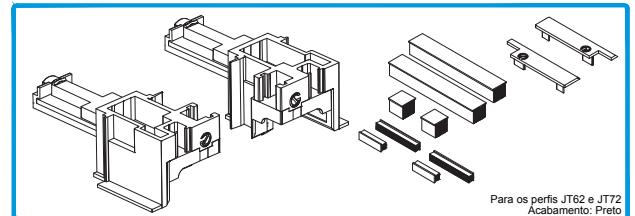

212109

Para os perfis JT62 e JT72  
Acabamento: Preto  
CONJ. TOPOS CANTO 90° JT

COLA  
GLUE  
COLE

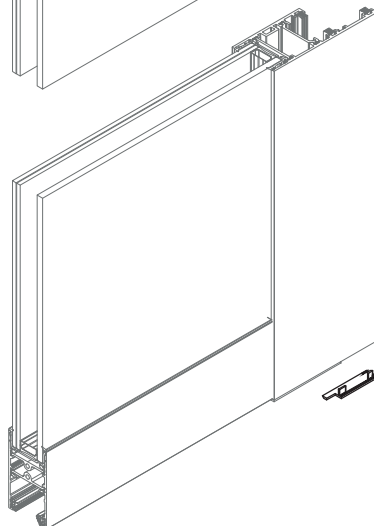
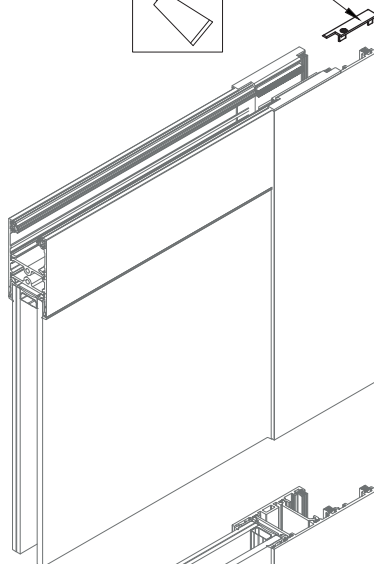

COLA  
GLUE  
COLE



## MONTAGEM DOS PERFIS ARO MÓVEL JT

JT MOBILE FRAME PROFILES ASSEMBLY

ASSEMBLAGE DES PROFILÉS OUVRANT JT

### 8 - Montagem de tipologia de ligação 2 folhas - FOLHA A.

Assembly of 2 sashes connection typology - **A SASH.**

Assemblage d'une typologie de liaison centrale 2 vantaux - **VANTAIL A.**

#### 8.1 - Fixação dos perfis JT61 e JT71.

JT61 and JT71 fixation.

Fixation des profilés JT61 et JT71.

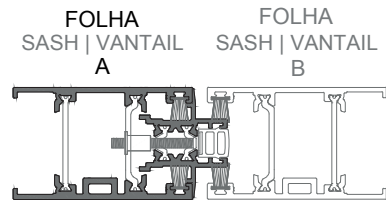

#### IMPORTANT | IMPORTANT | IMPORTANT:

Colocar os rebites antes de se fazer o fecho das esquadrias da folha móvel.

**Utilizar no mínimo 4 conjuntos para fixação do perfil JT72.**

Place the rivets before closing the frames of the mobile sash.

**Use at least 4 sets for fixing the JT72 profile.**

Placer les rivets avant de fermer les cadres de la cadre ouvrant.

**Utiliser au moins 4 kit pour la fixation du profilé JT72.**



212017

Para aplicação do perfil JT71  
CONJUNTO FIXAÇÃO  
FERRAGEM MÚLT.

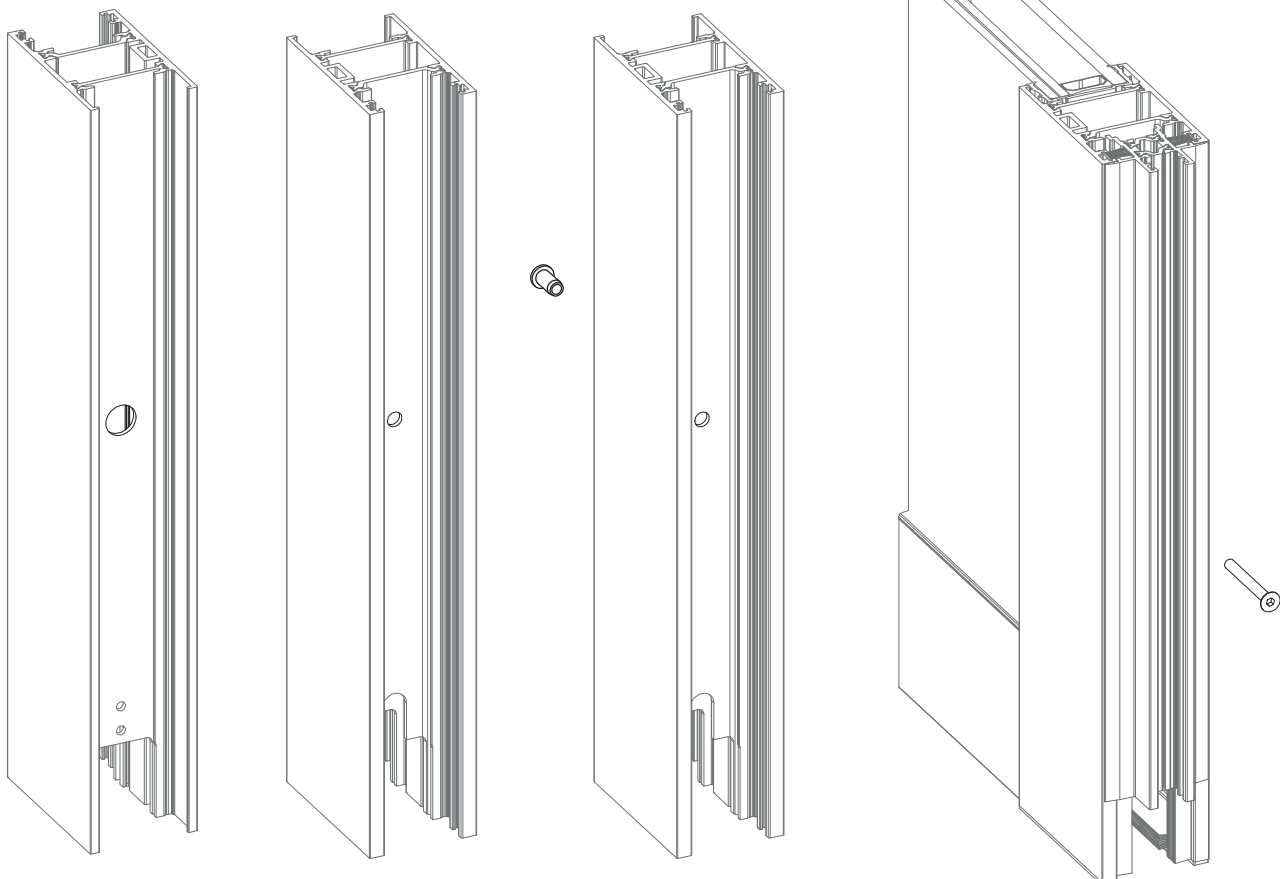
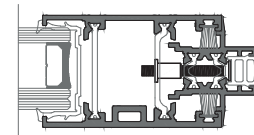
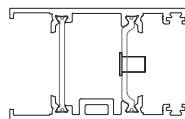
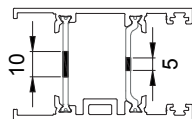



## MONTAGEM DOS PERFIS ARO MÓVEL JT

JT MOBILE FRAME PROFILES ASSEMBLY

ASSEMBLAGE DES PROFILÉS OUVRANT JT

### 8 - Montagem de tipologia de ligação 2 folhas - FOLHA A.

Assembly of 2 sashes connection typology - A SASH.

Assemblage d'une typologie de liaison centrale 2 vantaux - VANTAIL A.

#### 8.2 - Posicionar os calços para contra-fecho antes de se colocar a folha no vão.

Fit the locking plate shims before placing the sash in the frame.

Positionner les cales pour la contre-fermeture avant de placer le vantail dans le cadre.

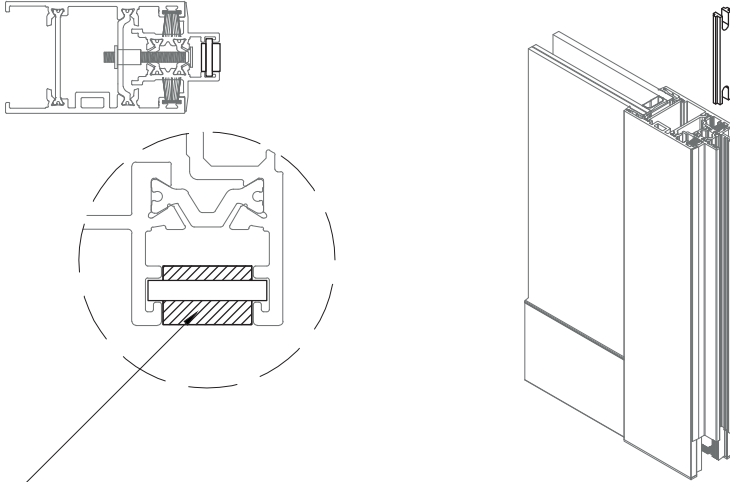
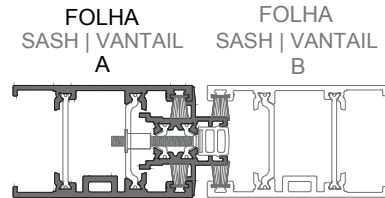

#### CALÇO NÃO SIMÉTRICO

(A referência "EXT" e o logotipo deverão ficar para a frente de forma a alinhar com o alumínio)

NOT SYMMETRICAL SHIM

(The "EXT" reference and the logo must stand in the front in alignment with the aluminium)

CALE NON SYMÉTRIQUE

(La référence "EXT" et le logo doivent être en avant pour s'aligner avec l'aluminium)

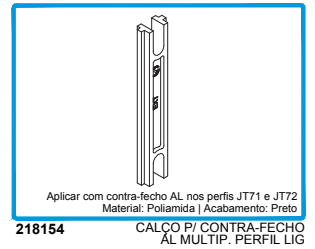

Este passo só se efetua quando se usa a ferragem multiponto SOS.

This step is only performed when using SOS multipoint hardware.

Cette étape n'est effectuée que lors de l'utilisation de serrure multipoint SOS.

#### 8.3 - Colocar os contras-ferchos na posição final.

Place the locking plates in its final position.

Placer les contre-fermeture en position finale.

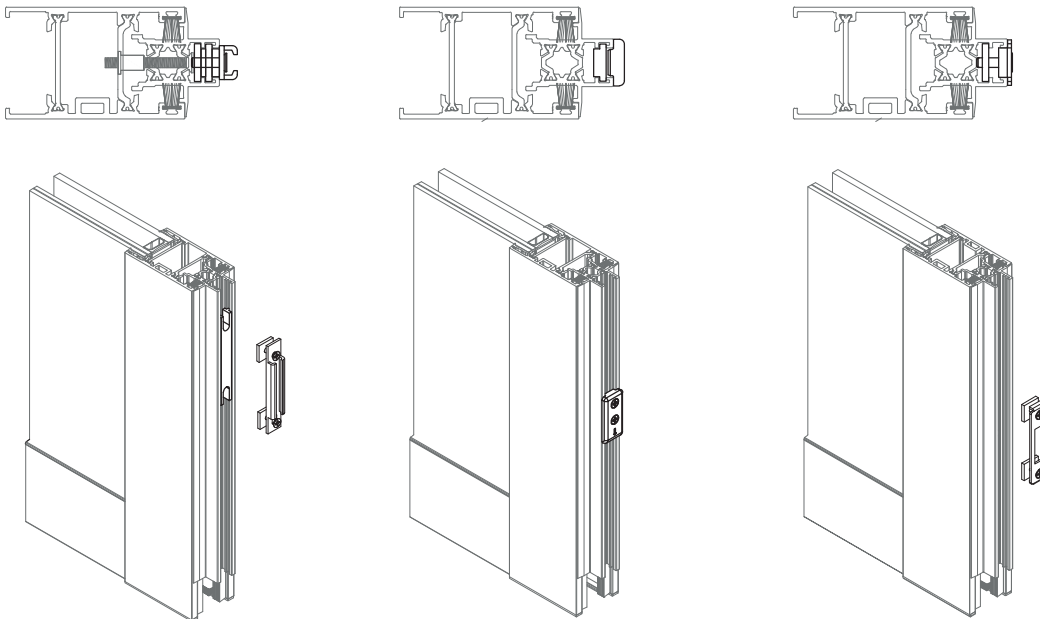

**FERRAGEM MULTIPONTO**  
MULTIPOINT HARDWARE  
SERRURE MULTIPOINT  
**SOS**

**FERRAGEM MULTIPONTO**  
MULTIPOINT HARDWARE  
SERRURE MULTIPOINT  
**SOT**

**FERRAGEM MULTIPONTO**  
MULTIPOINT HARDWARE  
SERRURE MULTIPOINT  
**ALU**

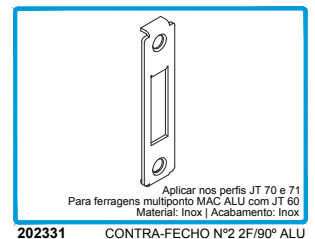
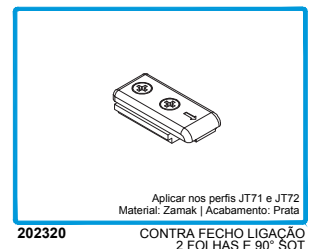
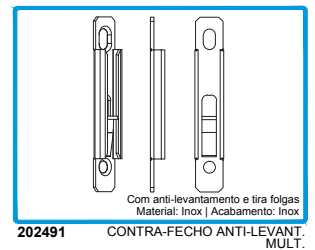
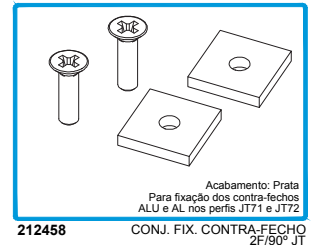

## MONTAGEM DOS PERFIS ARO MÓVEL JT

JT MOBILE FRAME PROFILES ASSEMBLY

ASSEMBLAGE DES PROFILÉS OUVRANT JT

### 8 - Montagem de tipologia de ligação 2 folhas - FOLHA A.

Assembly of 2 sashes connection typology - A SASH.

Assemblage d'une typologie de liaison centrale 2 vantaux - VANTAIL A.

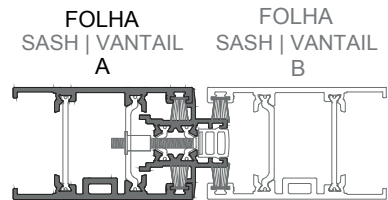

#### 8.4 - Colocar a folha no vão.

Place the sash in the frame.

Placer la vantail dans le cadre.

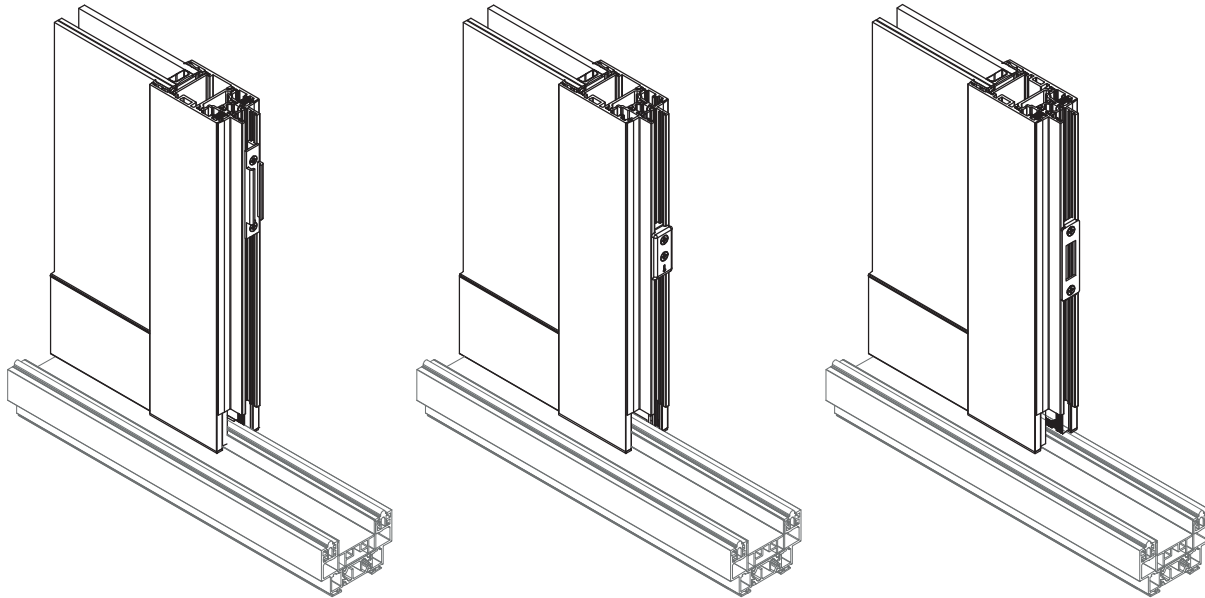

**FERRAGEM MULTIPONTO**  
MULTIPOINT HARDWARE  
SERRURE MULTIPONTO  
SOS

**FERRAGEM MULTIPONTO**  
MULTIPOINT HARDWARE  
SERRURE MULTIPONTO  
SOT

**FERRAGEM MULTIPONTO**  
MULTIPOINT HARDWARE  
SERRURE MULTIPONTO  
ALU

#### 8.5 - Colocar o conjunto topos ligação 2 folhas JT.

Place the JT 2 sashes connection end-caps kit.

Placer le kit d'embouts de connexion 2 vantaux JT.

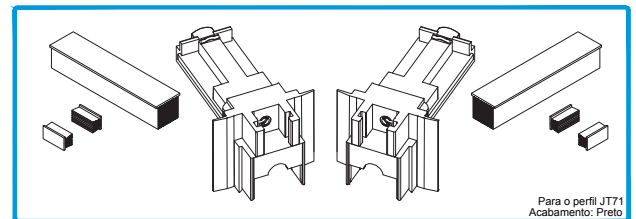

212104

CONJ. TOPOS LIGAÇÃO 2 FOLHAS JT

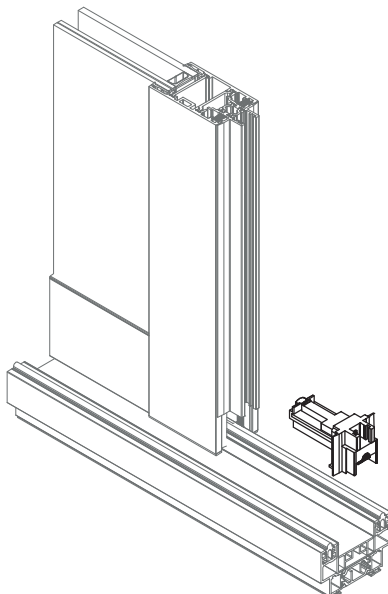

**MONTAGEM DOS PERFIS ARO MÓVEL JT**  
JT MOBILE FRAME PROFILES ASSEMBLY  
ASSEMBLAGE DES PROFILÉS OUVRANT JT

**8 - Montagem de tipologia de ligação 2 folhas - FOLHA A.**

Assembly of 2 sashes connection typology - **A SASH.**

Assemblage d'une typologie de liaison centrale 2 vantaux - **VANTAIL A.**

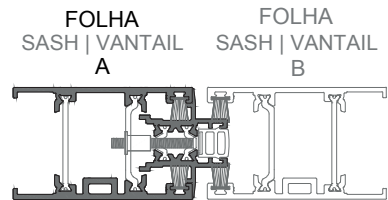

**8.6 - Colocar a junta tapa canal perfil lig. 2117 JT.**

Place the 2117 channel cover joint.

Monter le joint de couvercle de canal du profilé de liaison 2117 JT.

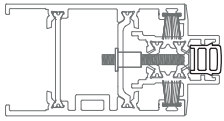

Considerar uma folga para permitir o funcionamento do gancho da ferragem.  
Consider a gap to allow the function of the hook of the hardware.  
Tener compte du dégagement pour permettre au crochet serrure de fonctionner.

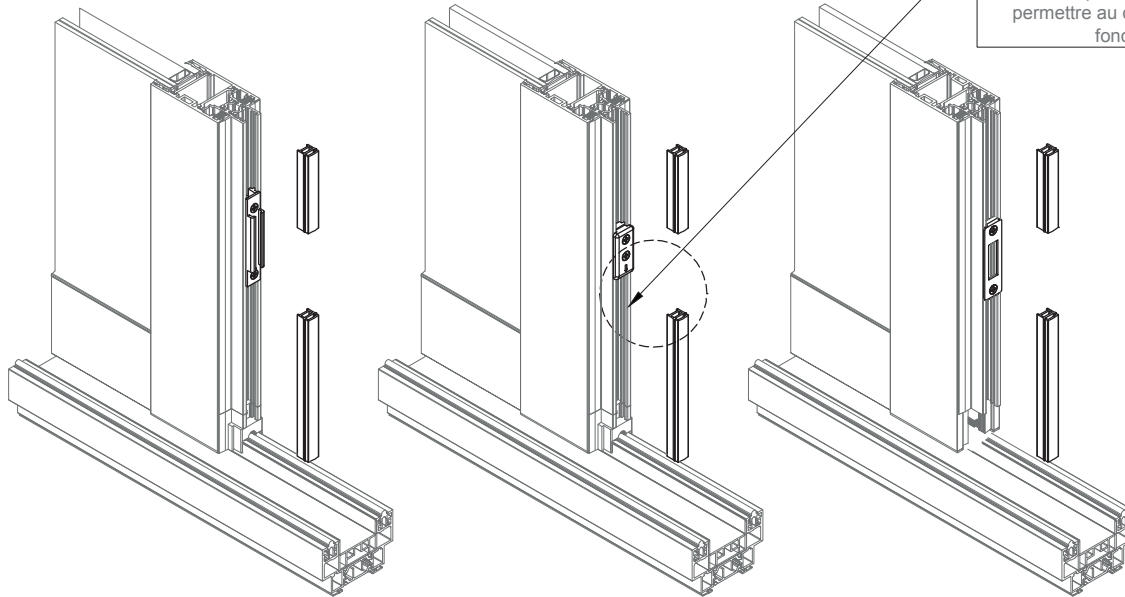

**FERRAGEM MULTIPONTO**  
MULTIPOINT HARDWARE  
SERRURE MULTIPOINT  
**SOS**

**FERRAGEM MULTIPONTO**  
MULTIPOINT HARDWARE  
SERRURE MULTIPOINT  
**SOT**

**FERRAGEM MULTIPONTO**  
MULTIPOINT HARDWARE  
SERRURE MULTIPOINT  
**ALU**

**8.7 - Pormenor final da colocação do perfil JT71 e dos seus acessórios.**

JT71 and its accessories final assembly detail.

Détail final du placement du profilé JT71 et de ses accessoires.

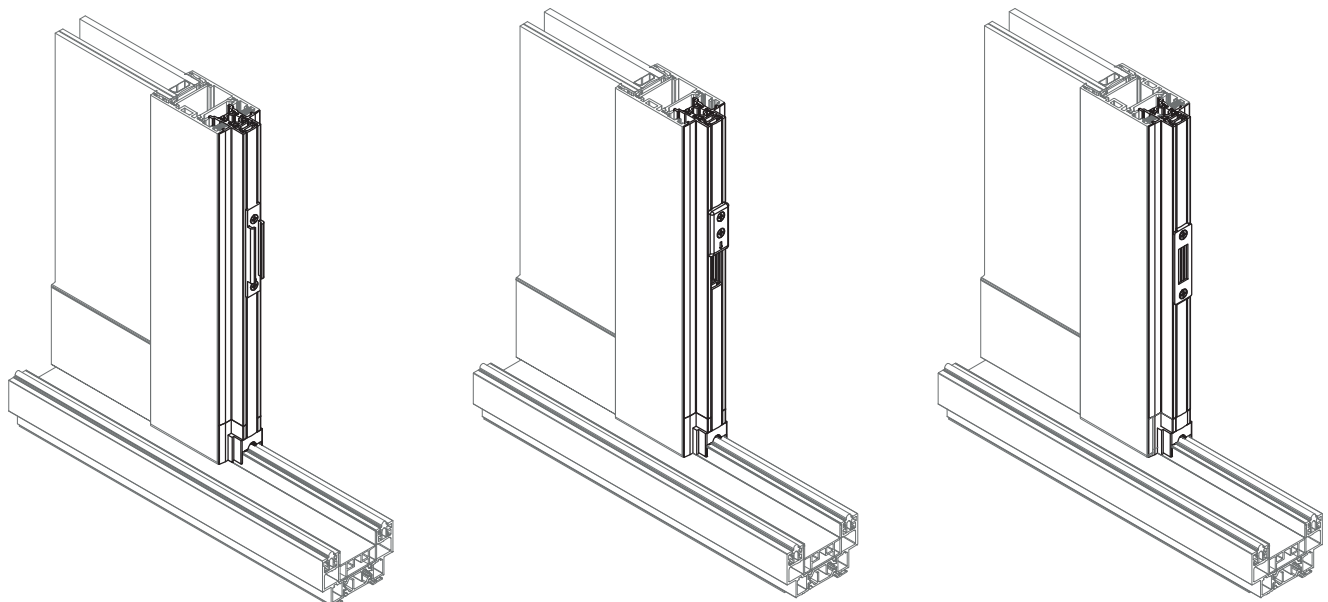

**FERRAGEM MULTIPONTO**  
MULTIPOINT HARDWARE  
SERRURE MULTIPOINT  
**SOS**

**FERRAGEM MULTIPONTO**  
MULTIPOINT HARDWARE  
SERRURE MULTIPOINT  
**SOT**

**FERRAGEM MULTIPONTO**  
MULTIPOINT HARDWARE  
SERRURE MULTIPOINT  
**ALU**

## MONTAGEM DOS PERFIS ARO MÓVEL JT-SLIM

JT-SLIM MOBILE FRAME PROFILES ASSEMBLY  
ASSEMBLAGE DES PROFILÉS OUVRANT JT-SLIM

1 - Montagem do vidro.  
Glass assembly.  
Assemblage du verre.

1.1 - Corte dos cantos da junta de vidro U.  
U glazing gasket corners cutting.  
Couper de les coins du joint du verre U.

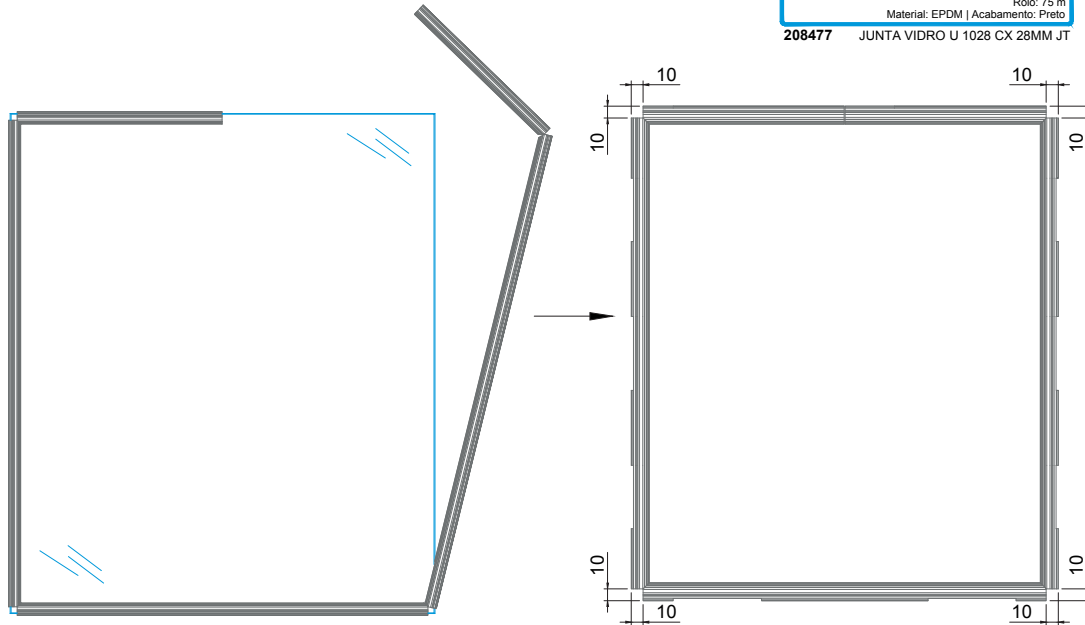

**IMPORTANTE | IMPORTANT | IMPORTANT:**

As operações a efetuar na junta deverão ser feitas com esta já aplicada no vidro, mas antes de se colocarem os perfis de alumínio.

The operations to be carried out on the joint must be done with it already applied in the glass, but before placing the aluminum profiles.

Les opérations à effectuer sur le joint doivent être effectuées avec celui-ci déjà appliqué sur le verre, mais avant la pose des profilés en aluminium.

1.2 - Corte adicional da junta de vidro U para colocação de calços de reforço horizontal JT-Slim.

U glazing gasket additional cutting for placing the JT-Slim reinforcement shims.

Coupe supplémentaire du joint du verre U pour la mise en place des cales de renforcement horizontal JT-Slim.

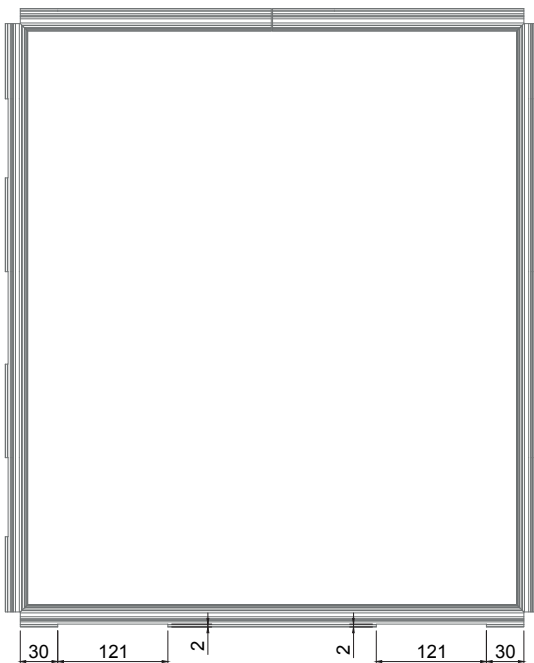
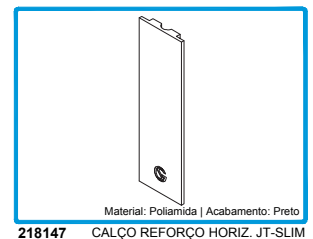

COLA  
GLUE  
COLLE



**IMPORTANTE | IMPORTANT | IMPORTANT:**

Esta operação apenas será necessária em vidros com mais de 80Kg.

This operation will only be necessary for glasses with more than 80Kg.

Cette opération ne sera nécessaire que pour les verres de plus de 80Kg.

## MONTAGEM DOS PERFIS ARO MÓVEL JT-SLIM

JT-SLIM MOBILE FRAME PROFILES ASSEMBLY

ASSEMBLAGE DES PROFILÉS OUVRANT JT-SLIM

### 1 - Montagem do vidro.

Glass assembly.

Assemblage du verre.

### 1.3 - Corte da junta de vidro U e furação dos perfis laterais e centrais, para colagem estrutural do vidro.

U glazing gasket cutting and drilling the lateral and central profiles, for structural bonding of the glass.

Couper le joint de verre en U et percer les profilés latéraux et centraux pour le collage structurel du verre.

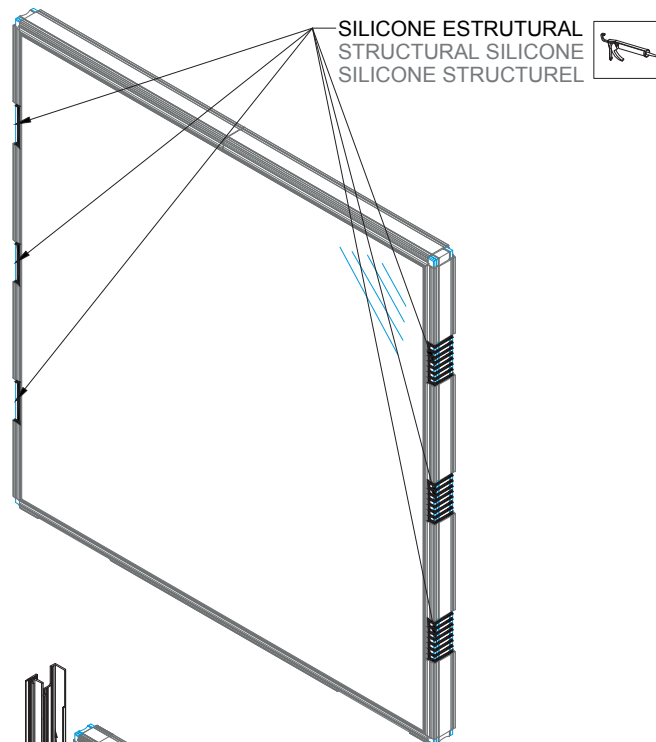
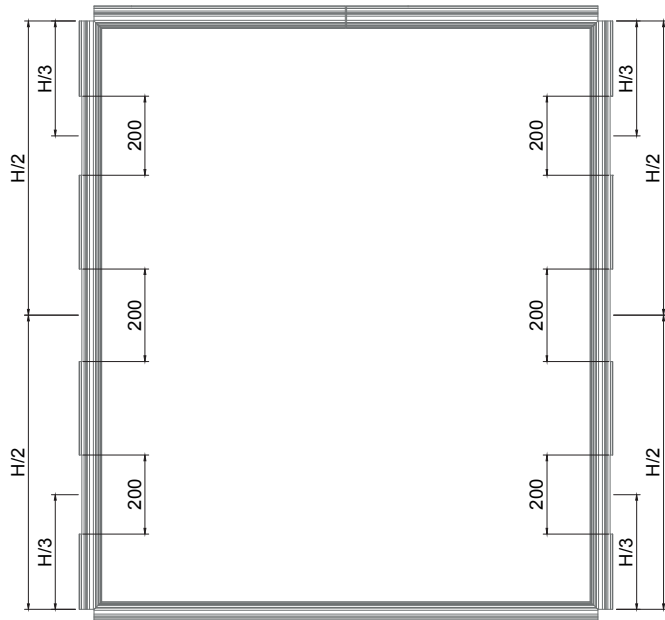

**IMPORTANTE | IMPORTANT | IMPORTANT:**  
Esta operação terá de ser feita em todos os vidros, para qualquer altura.  
This operation must be done on all glasses, for any height.  
Cette opération devra être effectuée sur toutes les verres, pour toute hauteur.

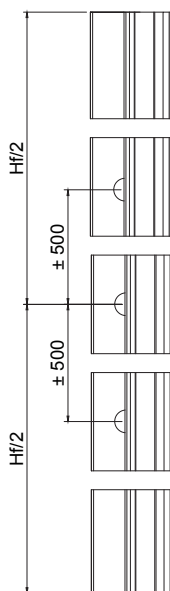
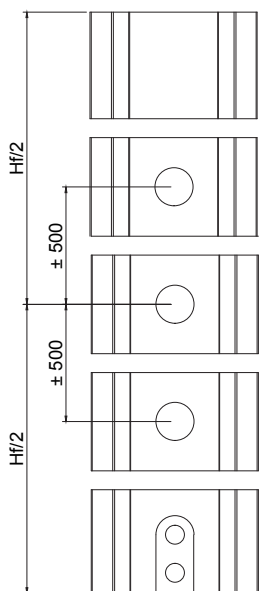
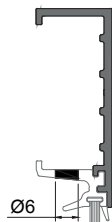
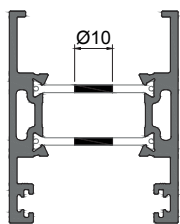

**SILICONE ESTRUTURAL**  
STRUCTURAL SILICONE  
SILICONE STRUCTUREL

**IMPORTANTE | IMPORTANT | IMPORTANT:**  
Preencher na totalidade o espaço entre o vidro e o perfil com silicone estrutural. Estudar a capacidade de adesão perfil-vidro com o fornecedor de silicone estrutural.  
Completely fill the space between the glass and the profile with the structural silicone.  
Study the profile-glass adhesion capacity with the structural silicone supplier.  
Remplir complètement l'espace entre le verre et le profilé avec du silicone structurel.  
Étudier la capacité d'adhésion profilé-verre avec le fournisseur de silicone structurel.

# MONTAGEM DOS PERFIS ARO MÓVEL JT-SLIM

JT-SLIM MOBILE FRAME PROFILES ASSEMBLY

ASSEMBLAGE DES PROFILÉS OUVRANT JT-SLIM

## 2 - Colocação dos carrinhos nas travessas inferiores.

Rollers placement on the bottom transoms.

Placement des roulettes sur les traverses inférieures.

### 2.1 - Carrinhos JT-Slim.

JT-Slim Rollers.

Roulettes JT-Slim.

**IMPORTANTE | IMPORTANT | IMPORTANT:**

Os carrinhos devem ser aplicados nas travessas inferiores antes de fechar o aro móvel.  
The rollers must be applied on the lower transoms before closing the mobile frame.  
Les roulettes doivent être appliqués sur les traverses inférieures avant de fermer le cadre ouvrant.

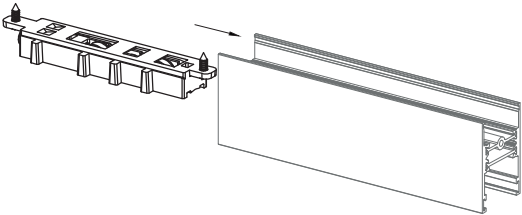
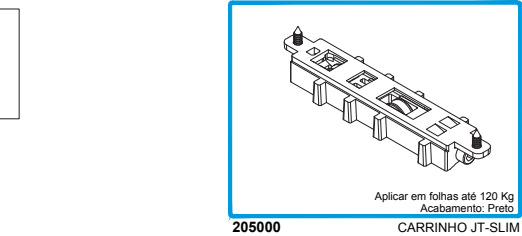
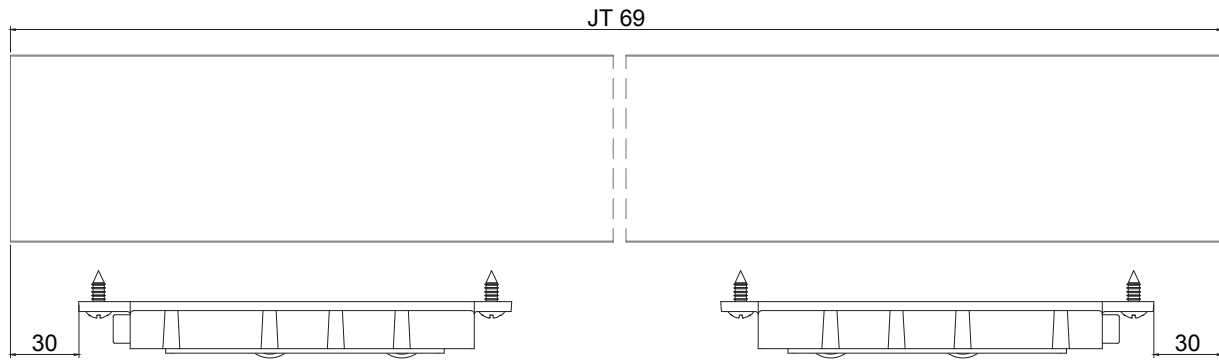
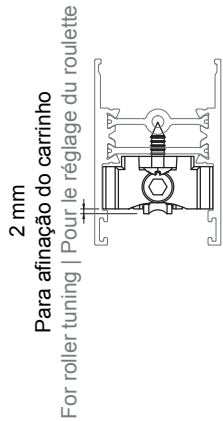

### 2.2 - Carrinhos JT-Slim 180kg.

180kg JT-Slim Rollers.

Roulettes JT-Slim 180kg.

**IMPORTANTE | IMPORTANT | IMPORTANT:**

Os carrinhos devem ser aplicados nas travessas inferiores, no interior da maquinação da poliamida e fixos nos 2 parafusos, antes de colocar a pelúcia e fechar o aro móvel.  
The rollers must be applied to the lower transoms, inside the polyamide machining and fixed to the 2 screws, before placing the pile seal and closing the mobile frame.  
Les roulettes doivent être appliqués sur les traverses inférieures, à l'intérieur de l'usinage polyamide et fixés aux 2 vis, avant de placer le joint brosse et de fermer le cadre ouvrant.

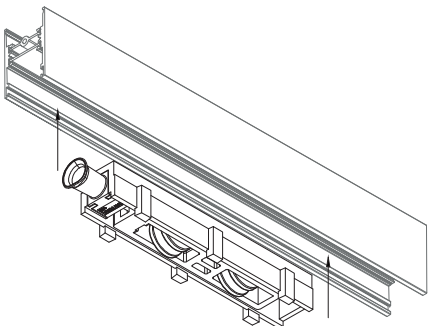
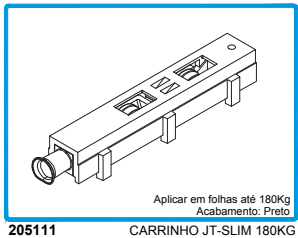
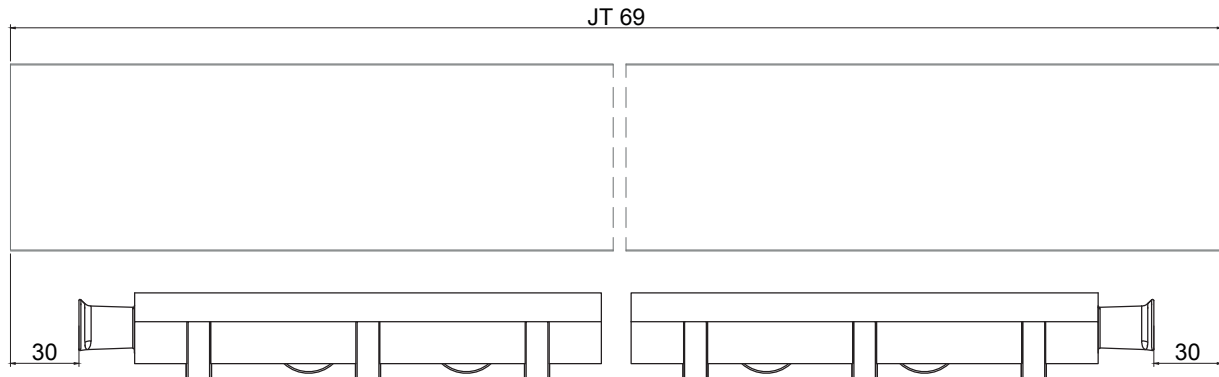
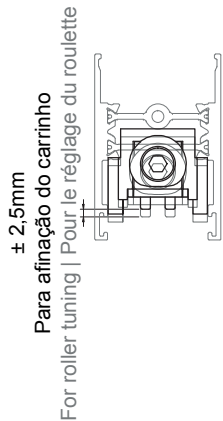

# MONTAGEM DOS PERFIS ARO MÓVEL JT-SLIM

JT-SLIM MOBILE FRAME PROFILES ASSEMBLY

ASSEMBLAGE DES PROFILÉS OUVRANT JT-SLIM

## 2 - Colocação dos carrinhos nas travessas inferiores.

Rollers placement on the bottom transoms.

Placement des roulettes sur les traverses inférieures.

## 2.3 - Carrinhos JT-Slim Heavy Duty.

Heavy Duty JT-Slim Rollers.

Roulettes JT-Slim Heavy Duty.

### IMPORTANTE | IMPORTANT | IMPORTANT:

Os carrinhos devem ser aplicados nas travessas inferiores, no interior da maquinação da poliamida e fixos nos 2 parafusos, antes de colocar a pelúcia e fechar o aro móvel.

The rollers must be applied to the lower transoms, inside the polyamide machining and fixed to the 2 screws, before placing the pile seal and closing the mobile frame.

Les roulettes doivent être appliqués sur les traverses inférieures, à l'intérieur de l'usinage polyamide et fixés aux 2 vis, avant de placer le joint brossse et de fermer le cadre ouvrant.

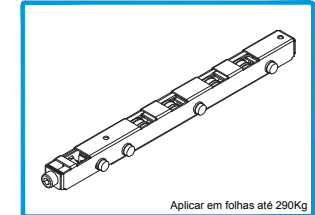

Aplicar em folhas até 290Kg

205202 CARRINHO JT-SLIM HEAVY DUTY

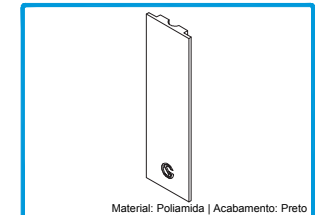

Material: Poliamida | Acabamento: Preto

218147 CALÇO REFORÇO HORIZ. JT-SLIM

**Obrigatório** colocar os calços  
**Mandatory** to put on the shims  
**Obligatoire** de mettre les cales

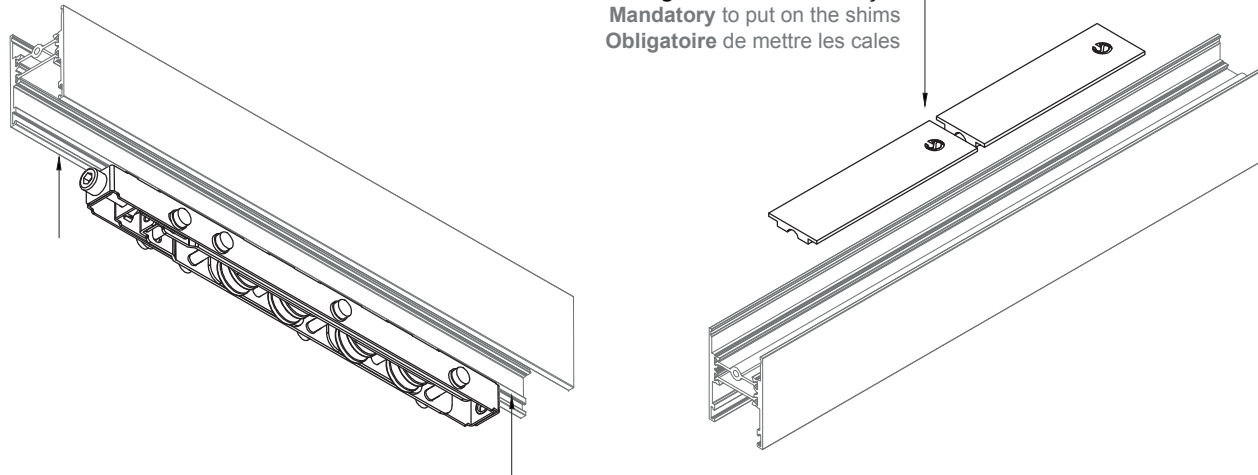

JT 69

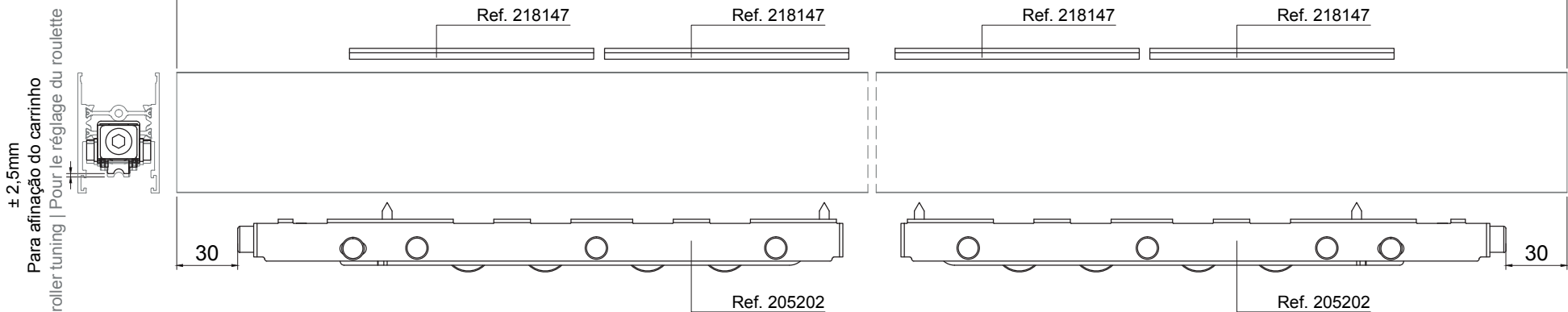



**MONTAGEM DOS PERFIS ARO MÓVEL JT-SLIM**  
JT-SLIM MOBILE FRAME PROFILES ASSEMBLY  
ASSEMBLAGE DES PROFILÉS OUVRANT JT-SLIM

**3 - Montagem e fixação do aro móvel.**

Mobile frame assembling and fixing.

Montage et fixation de le cadre ouvrant.

**3.1 - Colar as pelúcias nos topos laterais e centrais, antes de os colocar nos perfis.**

Glue the pile seals of the lateral and central end-caps before placing them in the profiles.

Coller les joint brosses sur les embouts latéraux et centraux avant de les placer sur les profilés.

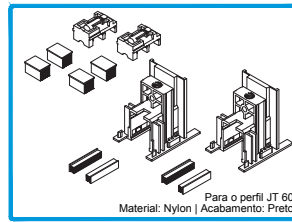

212131 CONJ. TOPOS LATERAL JT-SLIM

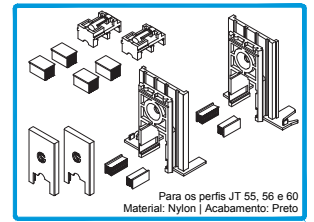

212133 CONJ. TOPOS CENTRAL JT-SLIM

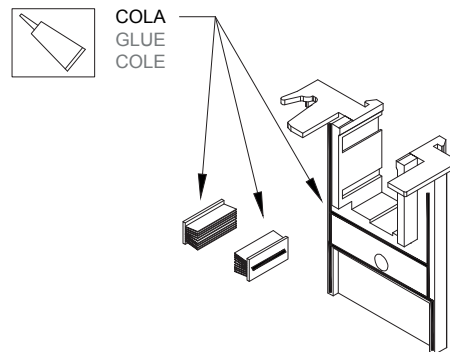
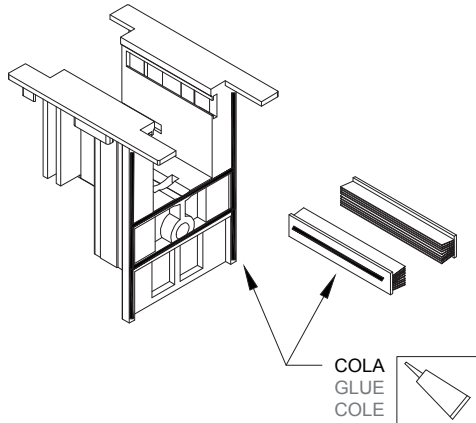

**3.2 - Colar as peças de poliamida ao perfil móvel.**

Glue the polyamide parts to the movable profile..

Coller les pièces en polyamide sur le profilé mobile.

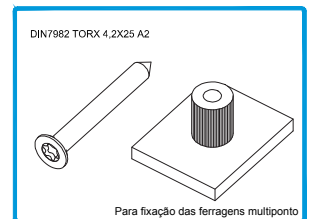

212373 CONJ. FIXAÇÃO JT-SLIM

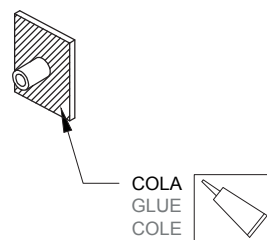
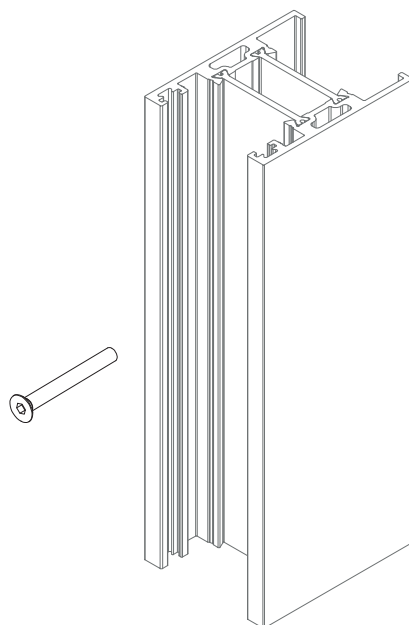

**MONTAGEM DOS PERFIS ARO MÓVEL JT-SLIM**  
JT-SLIM MOBILE FRAME PROFILES ASSEMBLY  
ASSEMBLAGE DES PROFILÉS OUVRANT JT-SLIM

**3 - Montagem e fixação do aro móvel.**

Mobile frame assembling and fixing.

Montage et fixation de le cadre ouvrant.

**3.3 - Aplicar silicone nas zonas de sobreposição dos perfis móveis verticais/horizontais e nos topos de fixação.**

Apply silicone in the overlapping areas of the vertical/horizontal mobile profiles and in the fixing end-caps.

Appliquer du silicone sur les zones de chevauchement des profilés ouvrant verticaux/horizontaux et des embouts de fixation.

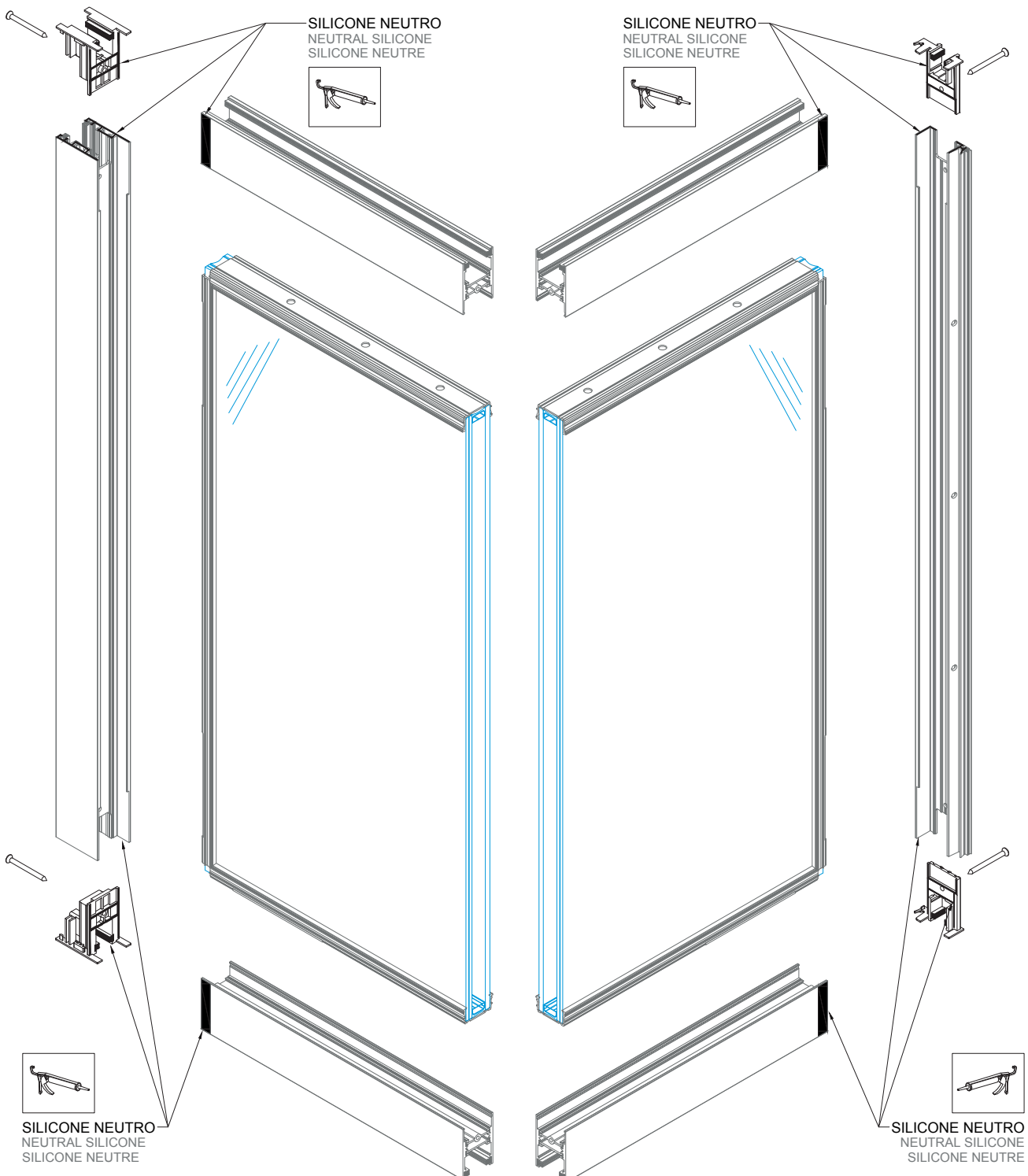
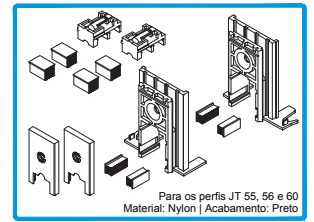
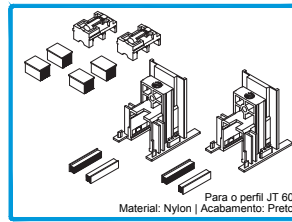

## MONTAGEM DOS PERFIS ARO MÓVEL JT-SLIM

JT-SLIM MOBILE FRAME PROFILES ASSEMBLY

ASSEMBLAGE DES PROFILÉS OUVRANT JT-SLIM

### 3 - Montagem e fixação do aro móvel.

Mobile frame assembling and fixing.

Montage et fixation de le cadre ouvrant.

### 3.4 - Etapas de montagem.

Assembly steps.

Étapes d'assemblage.

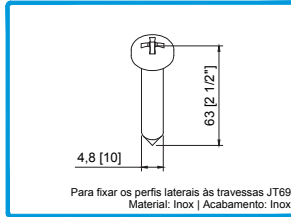

290087 PARAF. DIN7981 PH 4,8x63 INOX A2

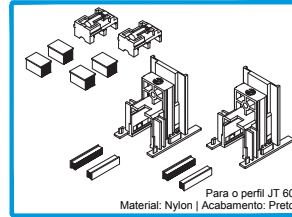

212131 CONJ. TOPOS LATERAL JT-SLIM

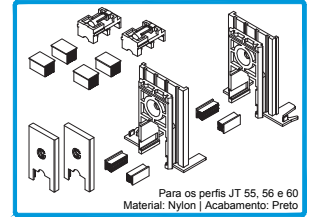

212133 CONJ. TOPOS CENTRAL JT-SLIM

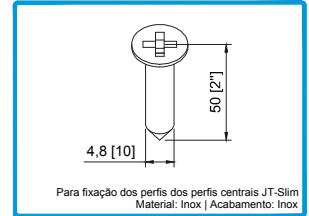

290091 PARAFUSO DIN7982 PH 4,8x50 A2

#### Passo | Step | Étape 1:

Colocar as travessas inferior e superior no vidro

Place the upper and lower transoms on the glass

Placer les traverses supérieure et inférieure sur le verre

#### Passo | Step | Étape 2:

Colocar o perfil lateral juntamente com os topos e encaixar nas travessas

Place the lateral profile together with the end-caps and fit it on the transoms

Placer le profilé latéral avec les embouts et monter sur les traverses

#### Passo | Step | Étape 3:

Colocar o perfil central com os topos e encaixar nas travessas.

Place the central profile with the end-caps and fit in the transoms.

Placer le profilé central avec les embouts et placer sur les traverses.

Estes acessórios deverão ser colocados quando a folha já estiver aplicada no vão.

These accessories should be placed when the sash is already applied in the frame.

Ces accessoires doivent être placés lorsque la vantail est déjà appliquée sur le cadre.

#### Passo | Step | Étape 4:

Fixar os perfis através do aparafusamento dos topos.

Fix the profiles by screwing the end-caps.

Fixer les profilés en vissant les embouts.

Estes acessórios deverão ser colocados quando a folha já estiver aplicada no vão.

These accessories should be placed when the sash is already applied in the frame.

Ces accessoires doivent être placés lorsque la vantail est déjà appliquée sur le cadre.

**MONTAGEM DOS PERFIS ARO MÓVEL JT-SLIM**  
JT-SLIM MOBILE FRAME PROFILES ASSEMBLY  
ASSEMBLAGE DES PROFILÉS OUVRANT JT-SLIM

**4 - Perfis móveis centrais.**

Central mobile profiles.  
Profils ouvrants centraux.

**4.1 - Aplicação dos Topos Centrais.**

Central End-caps application.  
Application des Embouts Centraux.

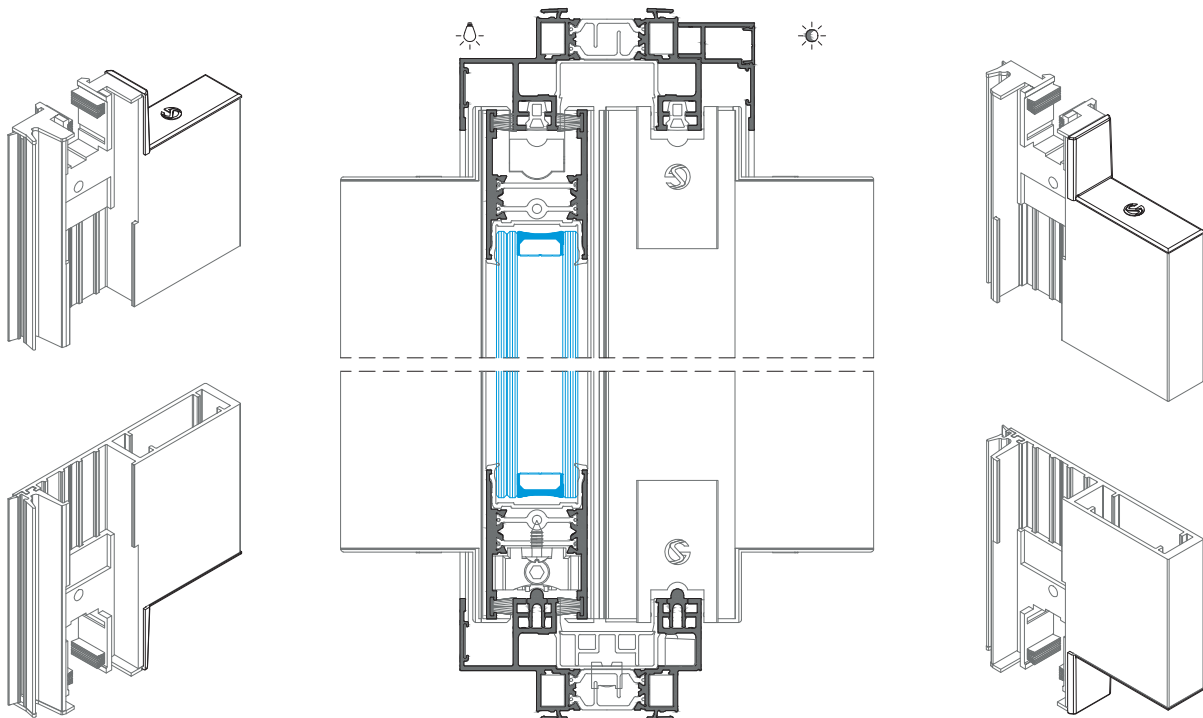
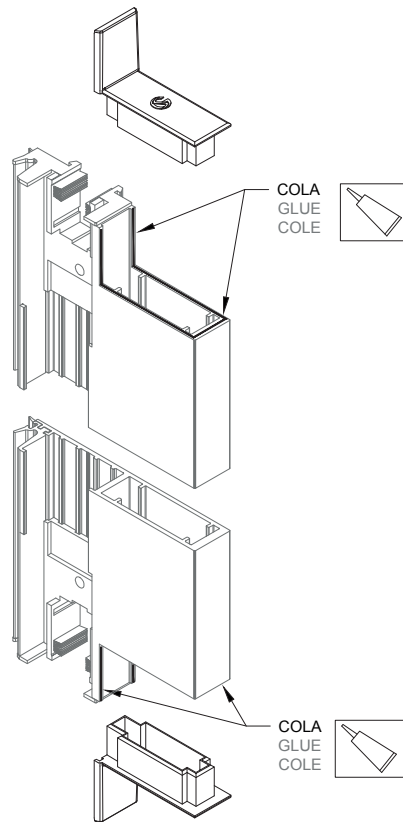
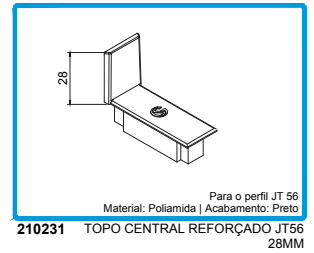

## MONTAGEM DOS PERFIS ARO MÓVEL JT-SLIM

JT-SLIM MOBILE FRAME PROFILES ASSEMBLY

ASSEMBLAGE DES PROFILÉS OUVRANT JT-SLIM

### 5 - Aplicação de contra-fechos no aro fixo.

Locking plates application in the fixed frame.

Application des contre-fermeture dans le cadre dormant.

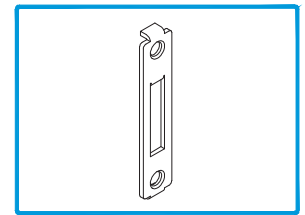
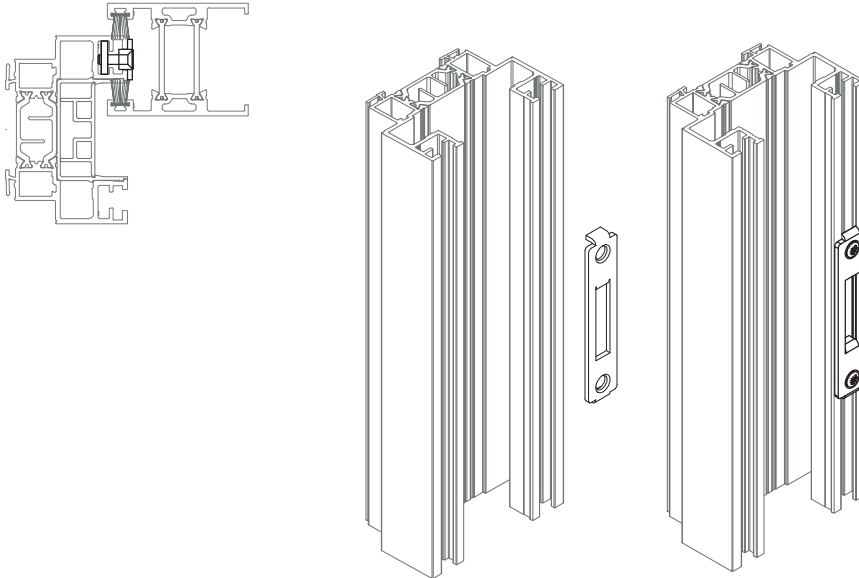

202330 CONTRA-FECHO ALU

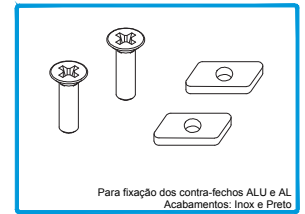

Para fixação dos contra-fechos ALU e AL  
Acabamentos: Inox e Preto  
212455 CONJ. FIX. CONTRA-FECHO  
AL MULTIP. JT

### 6 - Aplicação da junta tapa canal 2116 nos aros fixos. Esta junta deverá ser aplicada na padieira e nas laterais. Nas zonas onde se localizarão os contra-fechos, a junta deverá ser interrompida.

2116 channel cover joint applying in fixed frames. This joint must be applied in the lintel and the laterals. In the zones where the counter-locks will be located, the joint must be interrupted.

Application de la joint de couverture du canal 2116 sur les cadres dormants. Ce joint doit être appliqué sur le linteau et les côtés. Dans les zones où seront situées les contre-serrures, le joint doit être interrompu.

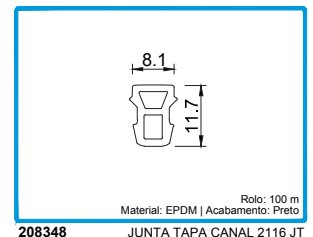
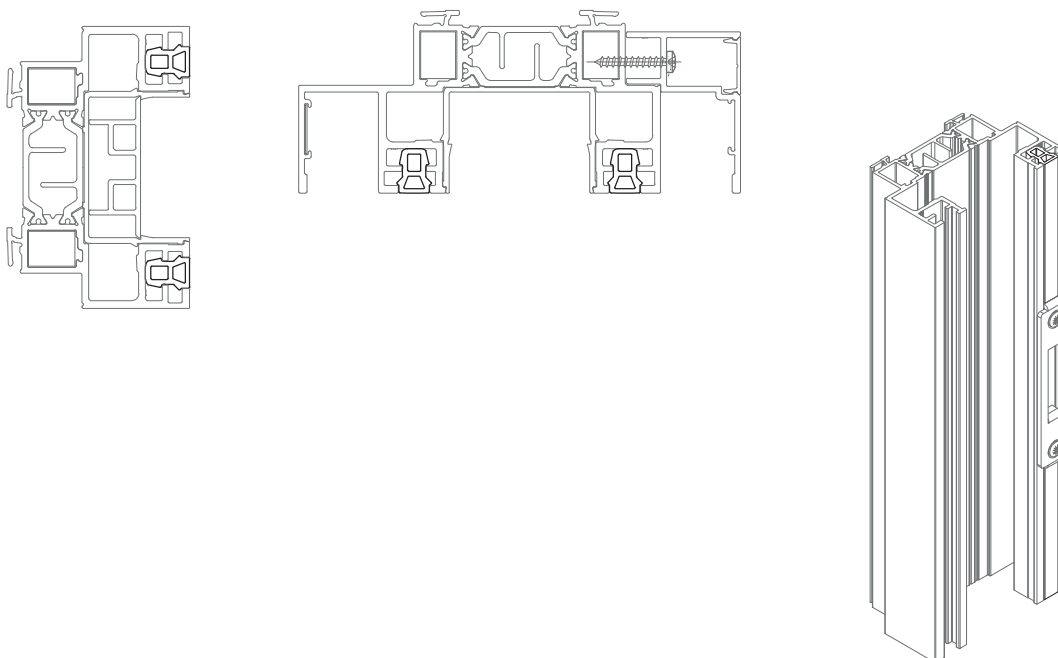

208348 JUNTA TAPA CANAL 2116 JT

Rolo: 100 m  
Material: EPDM | Acabamento: Preto

**MONTAGEM DOS PERFIS ARO MÓVEL JT-SLIM**  
JT-SLIM MOBILE FRAME PROFILES ASSEMBLY  
ASSEMBLAGE DES PROFILÉS OUVRANT JT-SLIM

**7 - Montagem de tipologia de canto 90° - FOLHA A.**

Assembly of 90° corner typology - **A SASH.**

Assemblage d'une typologie d'angle à 90° - **VANTAIL A.**

**7.1 - Fixação dos perfis JT62 e JT72.**

JT62 and JT72 fixation.

Fixation des profilés JT62 et JT72.

**FOLHA | SASH | VANTAIL A**

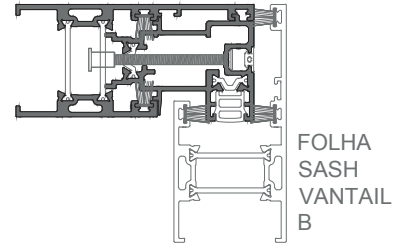

**IMPORTANTE | IMPORTANT | IMPORTANT:**

Colocar os rebites antes de se fazer o fecho das esquadrias da folha móvel.

**Utilizar no mínimo 4 conjuntos para fixação do perfil JT72.**

Place the rivets before closing the frames of the mobile sash.

**Use at least 4 sets for fixing the JT72 profile.**

Placer les rivets avant de fermer les cadres de la cadre ouvrant.

**Utiliser au moins 4 kit pour la fixation du profilé JT72.**

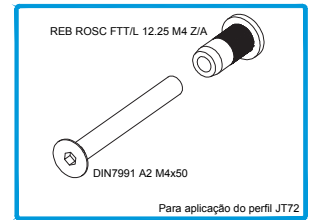

**212079** CONJ. FIXAÇÃO FERRAGEM MÚLTIPONTO JT72

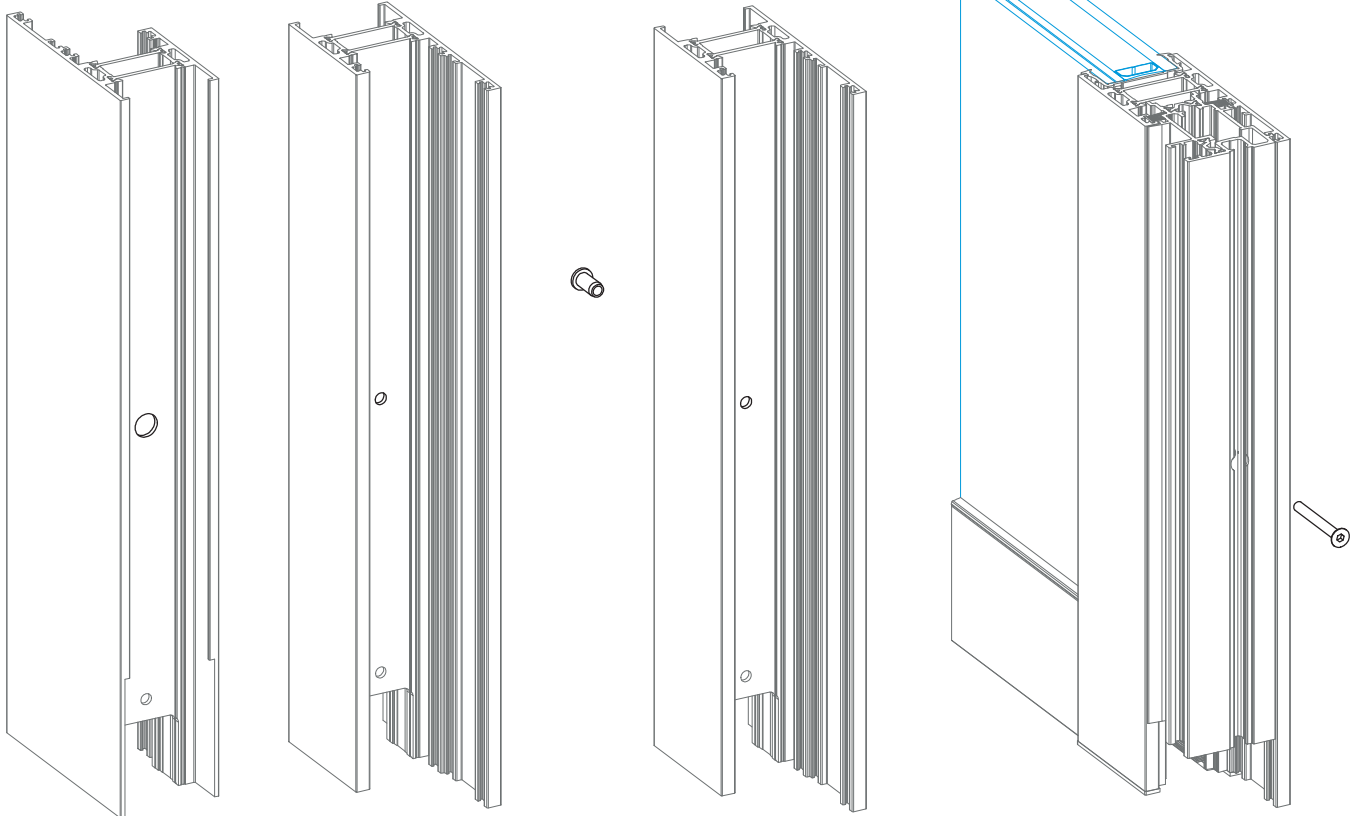
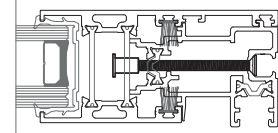
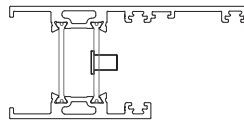
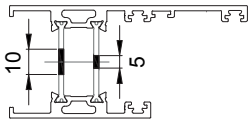

**MONTAGEM DOS PERFIS ARO MÓVEL JT-SLIM**  
JT-SLIM MOBILE FRAME PROFILES ASSEMBLY  
ASSEMBLAGE DES PROFILÉS OUVRANT JT-SLIM

**7 - Montagem de tipologia de canto 90° - FOLHA A.**

Assembly of 90° corner typology - **A SASH.**

Assemblage d'une typologie d'angle à 90° - **VANTAIL A.**

**7.2 - Colocar os calços para contra-fecho antes de se pôr a folha no vão.**

Place the locking plate shims before placing the sash in the frame.

Placer les cales pour la contre-fermeture avant de placer la vantail dans le cadre.

**FOLHA | SASH | VANTAIL A**

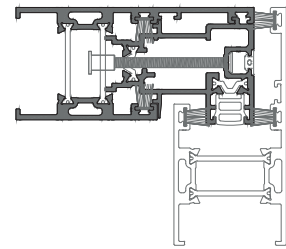

FOLHA  
SASH  
VANTAIL  
B

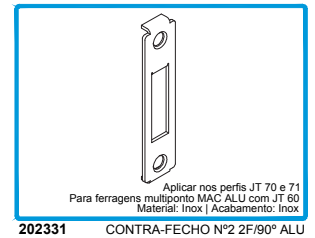
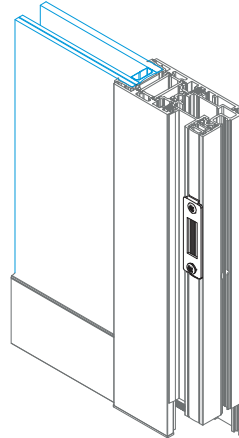
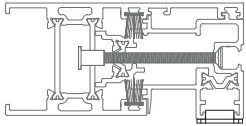

**7.3 - Colocar a folha no vão.**

Place the sash in the frame.

Placer la vantail dans le cadre.

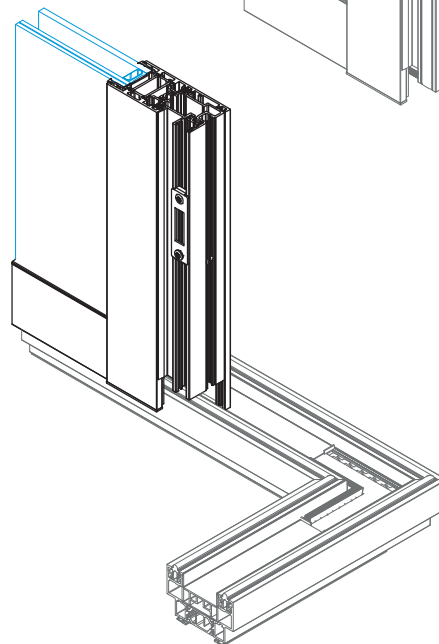

**8.4 - Colocar o conjunto topos canto 90° JT-Slim.**

Place the JT-Slim 90° corner end-caps kit.

Placer le kit d'embouts pour angle 90° JT-Slim.

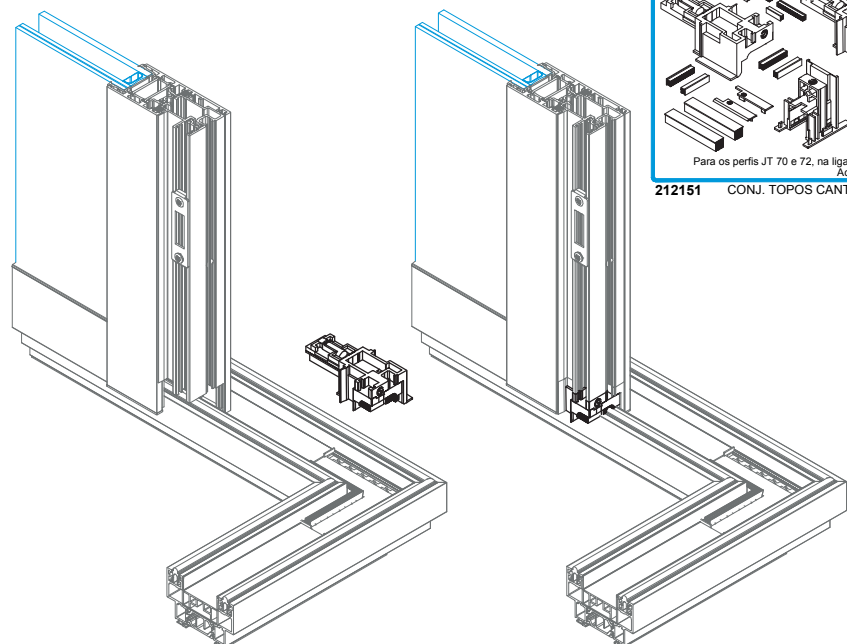
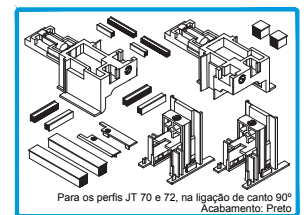



**MONTAGEM DOS PERFIS ARO MÓVEL JT-SLIM**  
JT-SLIM MOBILE FRAME PROFILES ASSEMBLY  
ASSEMBLAGE DES PROFILÉS OUVRANT JT-SLIM

**8 - Montagem de tipologia de canto 90° - FOLHA A.**

Assembly of 90° corner typology - **A SASH.**

Assemblage d'une typologie d'angle à 90° - **VANTAIL A.**

**7.5 - Colocar a junta tapa canal perfil lig. 2117 JT.**

Place the 2117 channel cover joint.

Monter le joint de couvercle de canal du profilé de liaison 2117 JT.

FOLHA | SASH | VANTAIL A

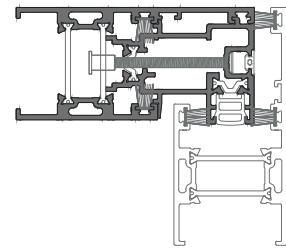

FOLHA  
SASH  
VANTAIL  
B

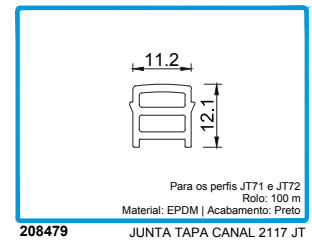
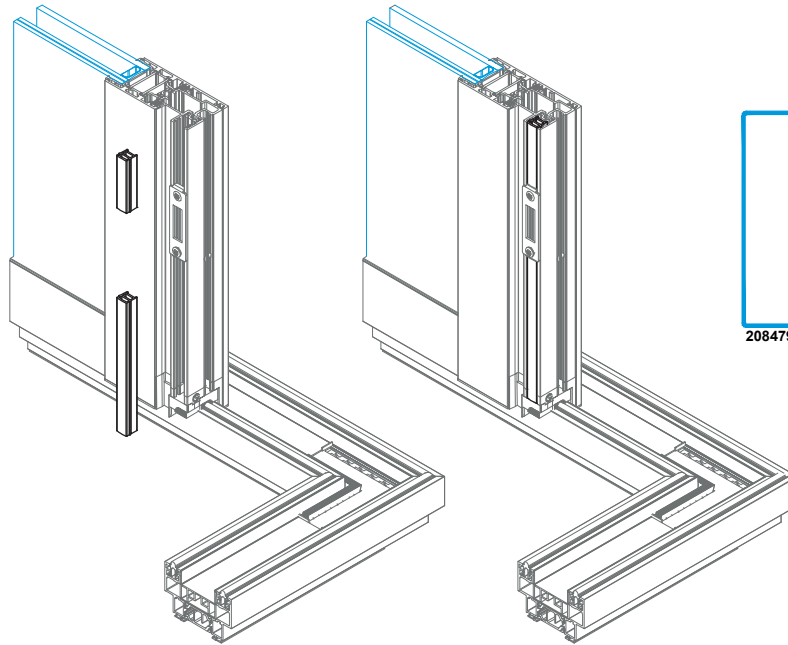
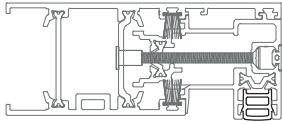

**7.6 - Colocar a junta VD 2415.**

Place the VD 2415 joint.

Placer le joint VD 2415.

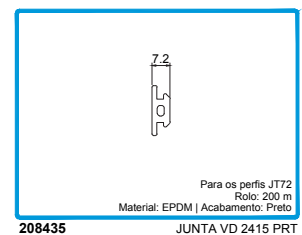
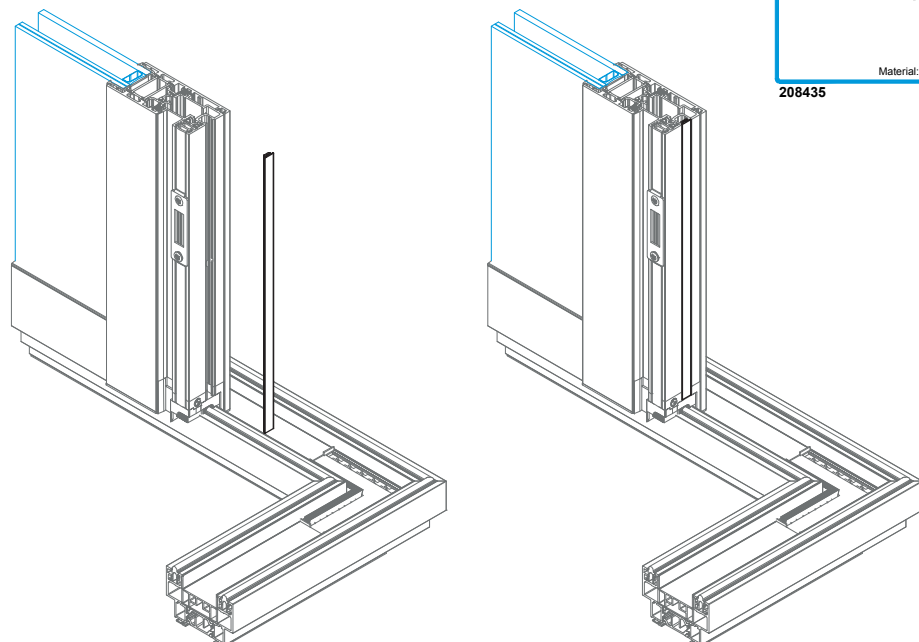
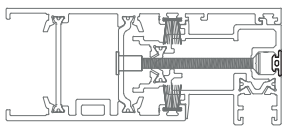

**MONTAGEM DOS PERFIS ARO MÓVEL JT-SLIM**  
JT-SLIM MOBILE FRAME PROFILES ASSEMBLY  
ASSEMBLAGE DES PROFILÉS OUVRANT JT-SLIM

**8 - Montagem de tipologia de canto 90° - FOLHA B.**

Assembly of 90° corner typology - **B SASH.**

Assemblage d'une typologie d'angle à 90° - **VANTAIL B.**

**8.1 - Colar os topos que sobraram do Conjunto de topos canto 90° JT.**

Paste the remaining end-caps from the 90° corner end-caps kit.  
Coller les embouts restants du kit d'embouts pour angle 90° JT.

**FOLHA | SASH | VANTAIL A**

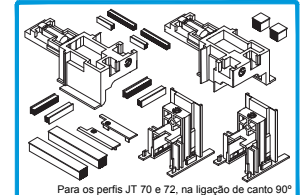
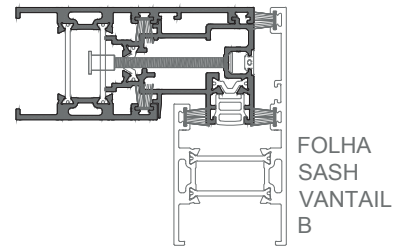

212151 CONJ. TOPOS CANTO 90° JT-SLIM

COLA  
GLUE  
COLE

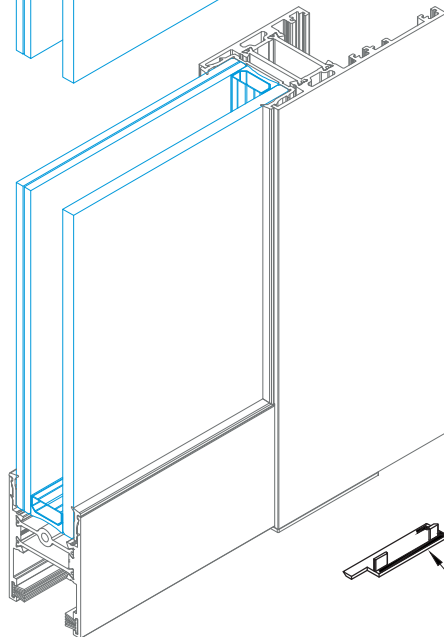
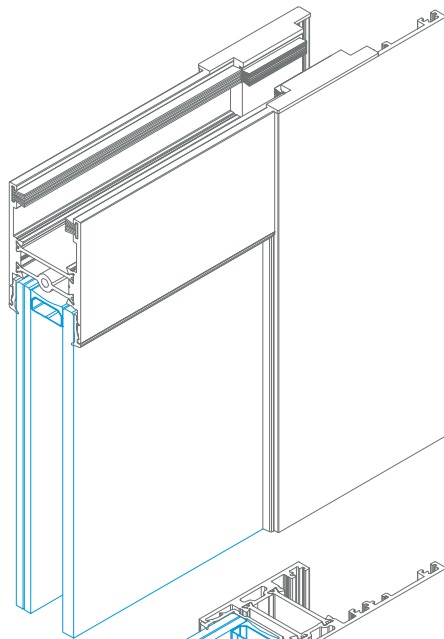
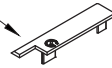

COLA  
GLUE  
COLE



**MONTAGEM DOS PERFIS ARO MÓVEL JT-SLIM**

JT-SLIM MOBILE FRAME PROFILES ASSEMBLY

ASSEMBLAGE DES PROFILÉS OUVRANT JT-SLIM

**9 - Montagem de tipologia de ligação 2 folhas - FOLHA A.**

Assembly of 2 sashes connection typology - **A SASH.**

Assemblage d'une typologie de liaison centrale 2 vantaux - **VANTAIL A.**

**9.1 - Fixação dos perfis JT60 e JT71.**

JT60 and JT71 fixation.

Fixation des profilés JT60 et JT71.

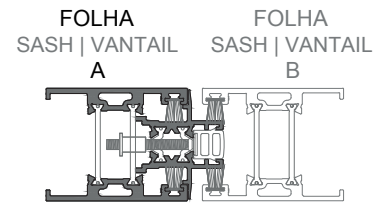

**IMPORTANTE | IMPORTANT | IMPORTANT:**

Colocar os rebites antes de se fazer o fecho das esquadrias da folha móvel.

**Utilizar no mínimo 4 conjuntos para fixação do perfil JT71.**

Place the rivets before closing the frames of the mobile sash.

**Use at least 4 sets for fixing the JT71 profile.**

Placer les rivets avant de fermer les cadres de la cadre ouvrant.

**Utiliser au moins 4 kit pour la fixation du profilé JT71.**

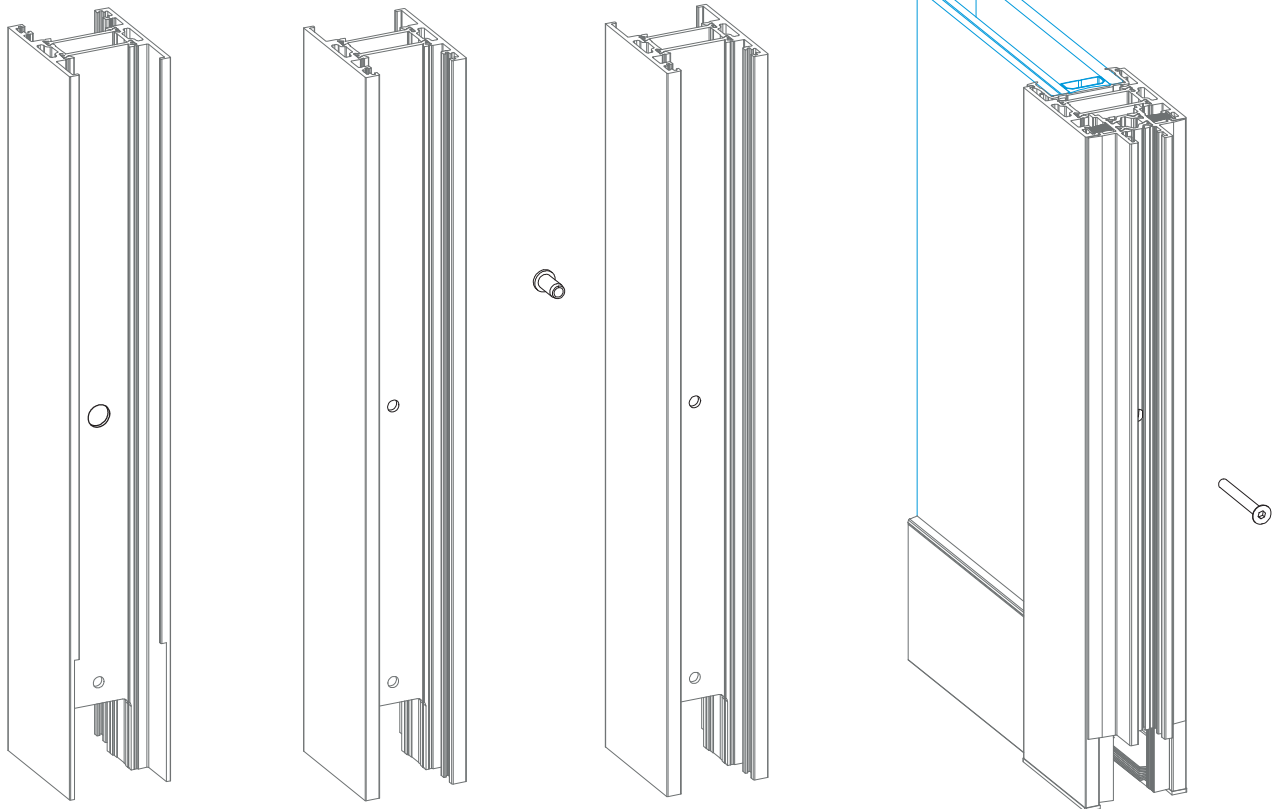
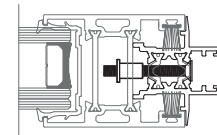
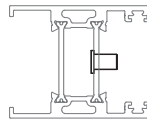
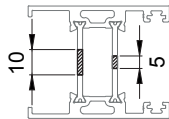
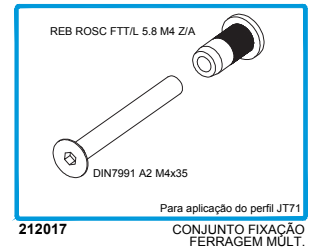

## MONTAGEM DOS PERFIS ARO MÓVEL JT-SLIM

JT-SLIM MOBILE FRAME PROFILES ASSEMBLY  
ASSEMBLAGE DES PROFILÉS OUVRANT JT-SLIM

### 9 - Montagem de tipologia de ligação 2 folhas - **FOLHA A.**

Assembly of 2 sashes connection typology - **A SASH.**

Assemblage d'une typologie de liaison centrale 2 vantaux - **VANTAIL A.**

### 9.2 - Colocar os contras-fechos na posição final e a junta tapa-canal 2117.

Place the locking plates in its final position and the 2117 channel cover joint.

Placer les contre-fermeture en position finale et le joint de couverture de canal 2117.

FOLHA SASH | VANTAIL A FOLHA SASH | VANTAIL B

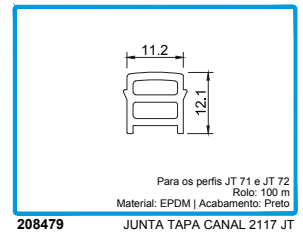
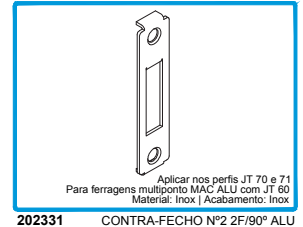
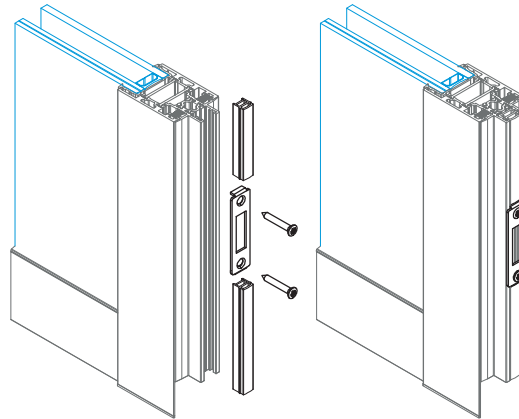
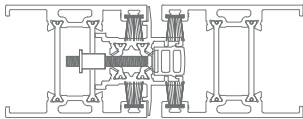
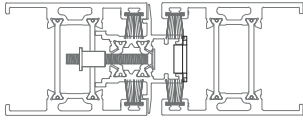
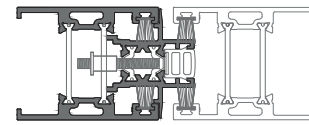

### 9.3 - Colocar a folha no vão.

Place the sash in the frame.

Placer la vantail dans le cadre.

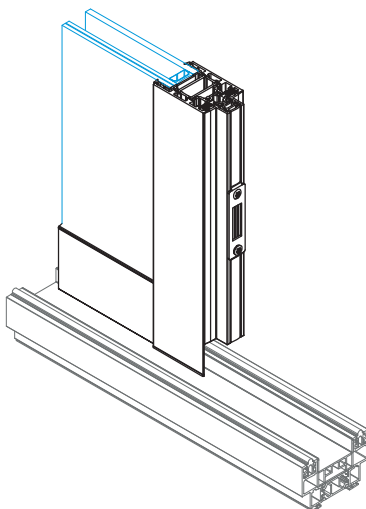

### 9.4 - Por último, colocar o conjunto topos ligação 2 folhas mini JT.

At last, place the JT 2 sashes connection end-caps kit.

Dernièrement, placer le kit d'embouts de connexion 2 vantaux JT.

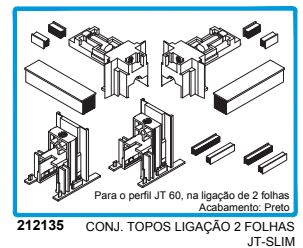
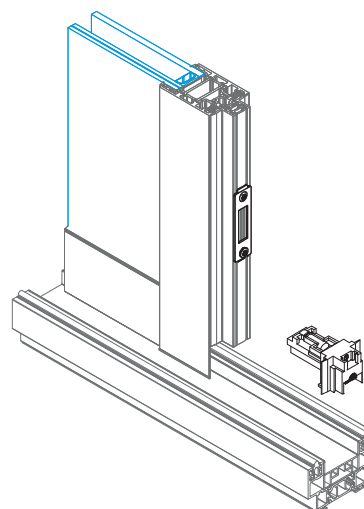

**MONTAGEM DE PERFIS DE CAPA**  
COVER PROFILES ASSEMBLY  
ASSEMBLAGE DES PROFILÉS DE CAPOT

- 1 - Aplicação do perfil JT 92 com silicone.**  
Application of JT 92 profile with silicone.  
Application du profilé JT 92 avec silicone.

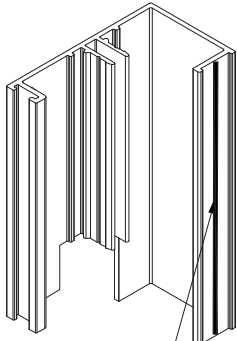

**SILICONE NEUTRO**  
NEUTRAL SILICONE  
SILICONE NEUTRE

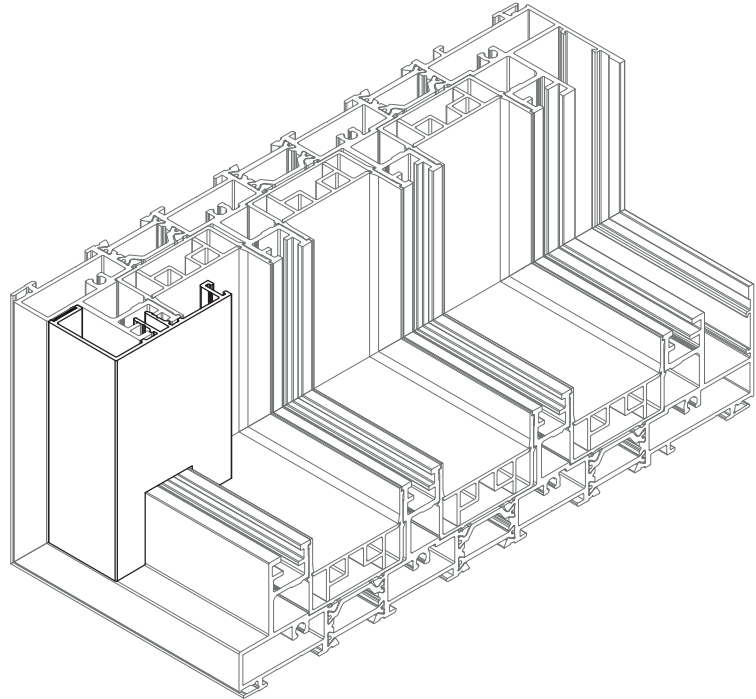

- 2 - Aplicação do perfil JT 89.**  
Application of JT 89 profile.  
Application du profilé JT 89.

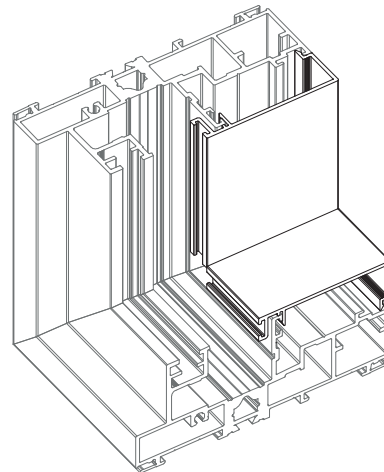
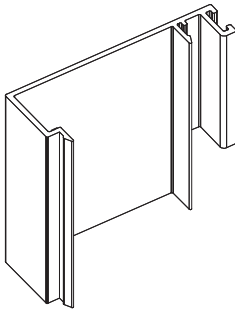

- 3 - Aplicação do perfil JT 89 e JT 91.**  
Application of JT 89 and JT 91 profile.  
Application du profilé JT 89 et JT 91.

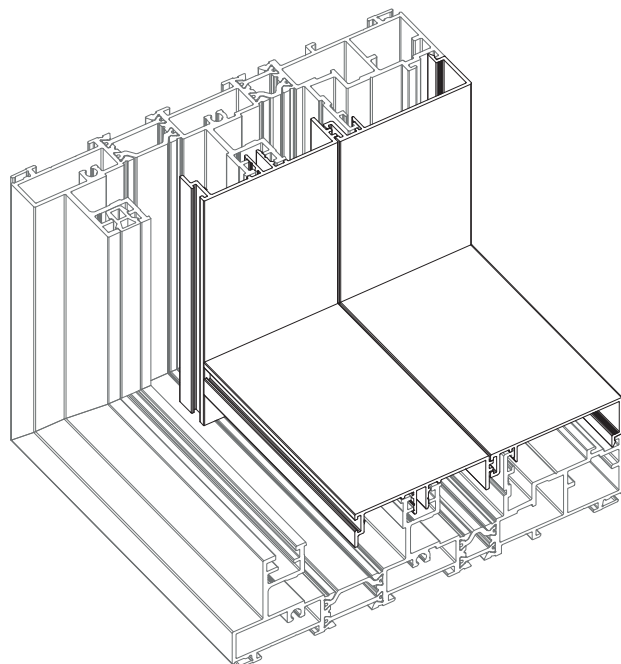
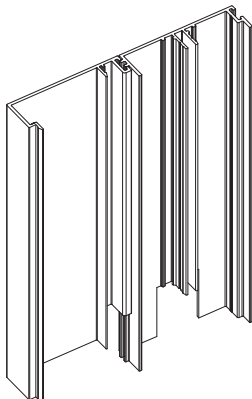

**MONTAGEM DO PERFIL DE REFORÇO/PUXADOR JE 35 + TAMPA OS 30**  
REINFORCEMENT PROFILE/HANDLE JÉ 35 + COVER OS 30 ASSEMBLY  
ASSEMBLAGE PROFILÉ DE RENFORCEMENT/POIGNÉE JE 35 + CAPOT OS 30

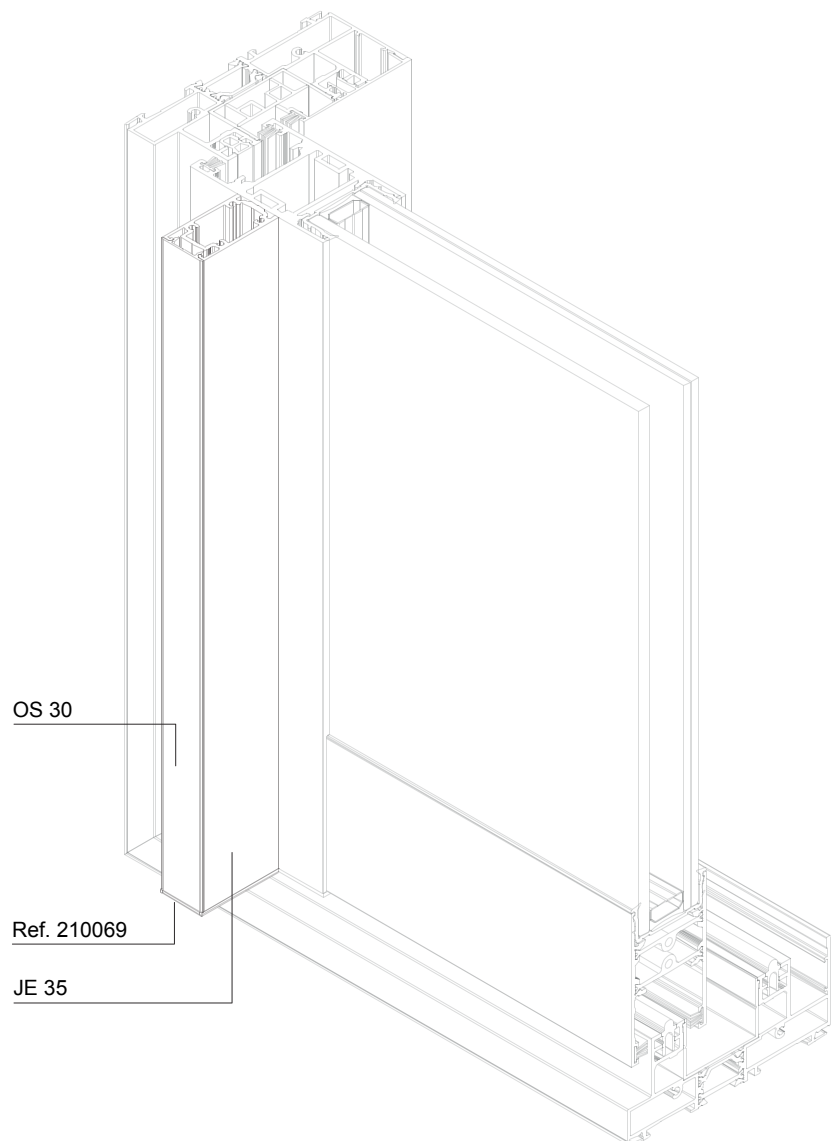
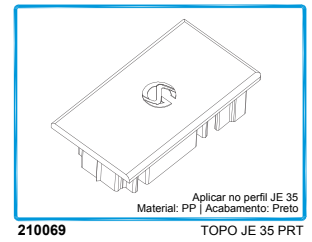
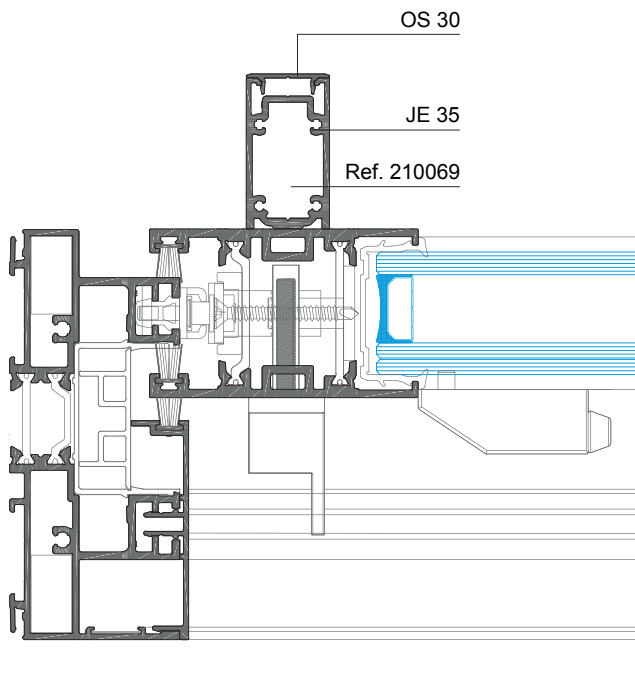

# VII

**ANOTAÇÕES**  
ANNOTATIONS | REMARQUES



<b>ATUALIZAÇÕES REALIZADAS NESTA VERSÃO</b> UPDATES DONE IN THIS VERSION   LES MISES À JOUR EFFECTUÉES DANS CETTE VERSION	
1	<b>Retiradas as páginas 14-1, 14-2, 14-3, 15-1 e 15-2 do Capítulo IV</b> Removed pages 14-1, 14-2, 14-3, 15-1 and 15-2 of Chapter IV Pages 14-1, 14-2, 14-3, 15-1 et 15-2 du chapitre IV supprimées
2	<b>As páginas referentes ao Capítulo IV (IV.11, IV.12 e IV.13) passam a ter como título "· COMBINAÇÃO JT + CENTRAL 20mm"</b> The pages referring to Chapter IV (IV.11, IV.12 and IV.13) are now entitled "JT + 20mm CENTRAL PROFILE COMBINATION" Les pages se référant au chapitre IV (IV.11, IV.12 et IV.13) s'intitulent désormais "COMBINAISON JT + PROFILÉ CENTRAL 20mm"
3	<b>Substituído o artigo Ref 212231 pelo artigo Ref 212273 nos Mapas de quantidades de todas as páginas referentes ao Capítulo IV (IV.11, IV.12 e IV.13)</b> Replacement of article Ref 212231 by article Ref 212273 in the Quantity Maps on all pages referring to Chapter IV (IV.11, IV.12 and IV.13). Remplacement de l'article réf. 212231 par l'article réf. 212273 dans le Carte des Quantités sur toutes les pages se référant au Chapitre IV (IV.11, IV.12 et IV.13).
4	<b>Corrigidas as medidas de corte no pormenor vertical, da tipologia da página IV.5-1</b> Corrected the cutting measures in the vertical detail of the typology on page IV.5-1 Correction des mesures de coupe dans le détail vertical de la typologie à la page IV.5-1
5	<b>Corrigido o material do calço reforço horizontal JT na Listagem de Acessórios (estava ABS e é em Poliamida)</b> Corrected the material of the JT horizontal reinforcement shim in the Accessories List (it was ABS and is now Polyamide). Correction du matériau de la cale de renforcement horizontal JT dans la Liste d'Accessoires (il était en ABS et est maintenant en polyamide).
6	<b>Atualizada a quantidade de parafusos nos Mapas de Quantidades dos Pormenores, nas tipologias das página IV.8, IV.9, IV.10, IV.11, IV.12 e IV.13</b> Updated the quantity of screws in the Detail Quantity Maps, in the typologies on pages IV.8, IV.9, IV.10, IV.11, IV.12 and IV.13. Mise à jour de la quantité de vis dans les Cartes de Quantité des détails, dans les typologies des pages IV.8, IV.9, IV.10, IV.11, IV.12 et IV.13.
7	<b>Substituído o artigo Ref 218198 pelo artigo Ref 218149 nos Mapas de quantidades das páginas IV.11, IV.12 e IV.13</b> Replacement of article Ref 218198 by article Ref 218149 in the Quantity Maps on pages IV.11, IV.12 and IV.13 Remplacement de l'article 218198 par l'article 218149 dans les Quantités aux pages IV.11, IV.12 et IV.13.
8	<b>Acrescentado o artigo Ref 212252 nos Mapas de quantidades das páginas IV.13</b> Added article Ref 212252 to the quantity charts on pages IV.13 Ajout de l'article 212252 dans les tableaux de quantités des pages IV.13.

Este Catálogo Técnico poderá sofrer alterações por motivos técnicos, sem aviso prévio.

Qualquer encomenda deverá ser sujeita a confirmação dos nossos serviços.

A publicação do presente catálogo técnico anula qualquer versão prévia em vigor, sendo válida até nova atualização.

This Technical Catalogue might be subjected to changes due to technical reasons, without previous warning.

All orders must pass through the confirmation of our technical services.

The publication of this technical catalogue cancels any previous version in use, and is valid until a new update.

Ce Catalogue Technique pourra être modifié sans pré avis de notre part, due à des raisons techniques.

Toute commande devra être confirmée par nos services.

La publication de ce catalogue technique annule toute version antérieure en vigueur, et est valable jusqu'à une nouvelle mise à jour.



Licença nº 1406 - SOSOARES  
Licença nº 1411 - ALFA SUL



Licença nº 809 - SOSOARES  
Licença nº 817 - PORTALEX

#### ALFA SUL

EN Lisboa-Sintra Km 14  
2725-397 Mem Martins

T +351 219 265 090\* | F +351 219 265 098\*  
E [alfa.sul@sosoares.pt](mailto:alfa.sul@sosoares.pt)

#### ALULIDER

Pavilhão Industrial H - Plataforma 13D  
Zona Franca Industrial  
9200-047 Caniçal - Madeira

T +351 291 960 494\* | F +351 291 960 497\*  
E [alulider@sosoares.pt](mailto:alulider@sosoares.pt)

#### PORTALEX

Estrada de S. Marcos, 23  
2735-521 Cacém

T +351 210 412\* | F +351 210 412 507\*  
E [comercial@portalex.eu](mailto:comercial@portalex.eu)

#### SOSOARES

Rua do Campo Alegre, 474  
4150-170 Porto

T +351 226 096 709\* | F +351 226 005 642\*  
E [comercial@sosoares.pt](mailto:comercial@sosoares.pt)

\*Chamada para rede fixa nacional Portuguesa  
Portuguese fixed network call  
Appels vers le réseau fixe Portugais

[www.sosoares.pt](http://www.sosoares.pt)  
[www.portalex.eu](http://www.portalex.eu)